

MLC100-1

Product Guide

ASME B30.5
Metric



Features

- 100 t capacity
- 370,5 t-m maximum load moment
- 61,0 m main boom
- Max boom + fixed jib combination:
58,0 m + 18,3 m
- 223,71 kW Tier 4 Final engine
- 205 kW Tier 3 engine

MANITOWOC MLC100-1

The MLC100-1 provides a broad range of features that will undoubtedly be translated into job -site benefits that increase productivity and save money.

Features

> New Cab Design

- 10% more legroom for operator
- Full high back seat with headrest and moveable riser supports operator comfortably
- Utilizes Crane Control System (CCS)
- Storage shelving located in the rear of the cab
- Redesigned consoles providing more legroom
- Left side console rotates for improved egress
- Six-way electric seat riser/slider



> Efficient Self-Assembly

- Gantry raised counterweight reduces components and maintenance
- Boom butt mounted sheaves allow for reeving assembly hook without installing boom top
- Additional boom butt mounted sheave allows for carbody counterweight installation without outside assist
- Button style wire rope terminations for easy reeving



Job site benefits

Transport and Assembly

- Designed to be transported with minimal permitted loads
- Increased hook height allows for complete self-assembly with various trailer heights
- Self Assembly sheaves in boom butt allow self-assembly without installation of boom top saving time during the assembly process

Serviceability and support

- Elimination of wireless components to reduce complexity for increased reliability
- Cummins engine, cooler, air cleaner and after treatment package allows for better serviceability
- Crane Control System (CCS) allows for troubleshooting through the control system
- Codes can be cross referenced through the Manitowoc diagnostics code app
- Supported by Manitowoc's world class dealer network



Manitowoc Crane Care when you need it.
The assurance of the world's most advanced crane service and support to get you back to work fast.



Manitowoc Finance helps you get right to work generating profits for your business.
Financial tools that help you capitalize on opportunity with solutions that fit your needs.

Contents

Outline dimensions5

Transport data7

Performance data8

Boom combinations9

Working range/load charts - Main boom10

Working range/ load charts - Fixed jib12

Specifications14

Provided for Free by Trenchwell.com
Shop Aftermarket Parts

Outline dimensions

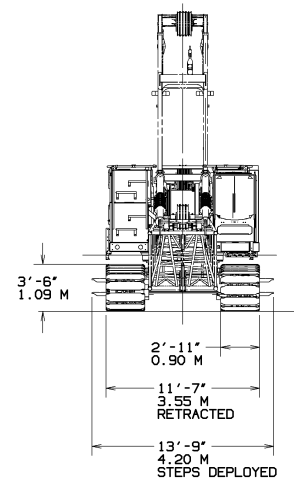
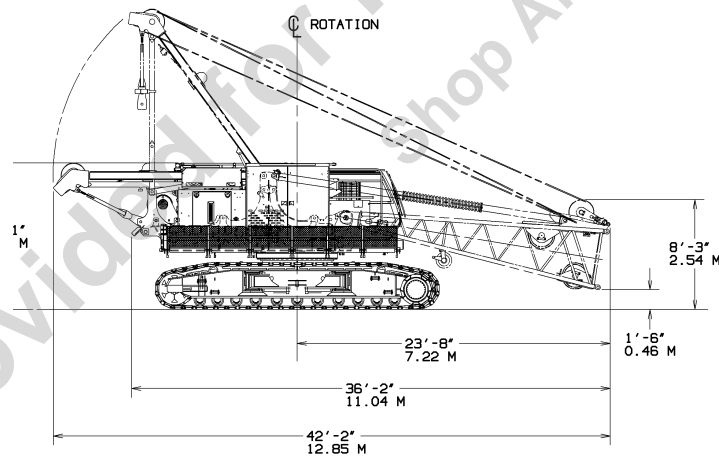
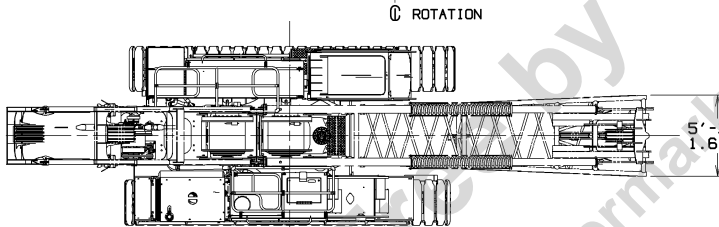
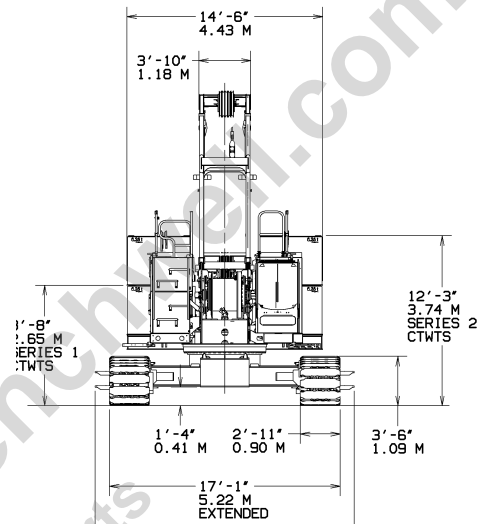
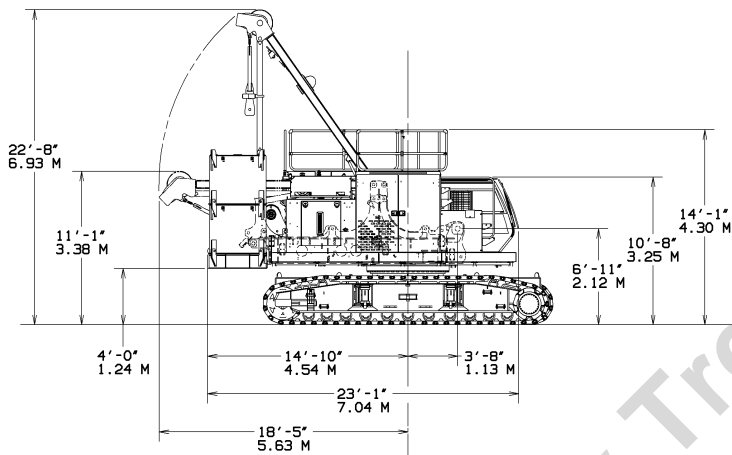
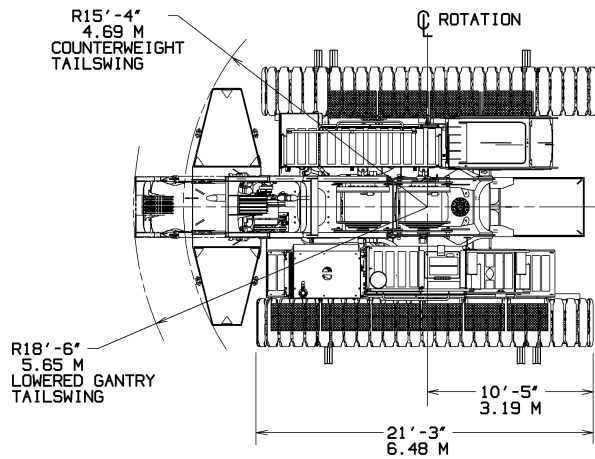

Outline dimensions

Rotating Bed w/ Boom Butt

Height	3,4 m
Length	12,9 m
Width	3,6 m
Weight	41.5 t

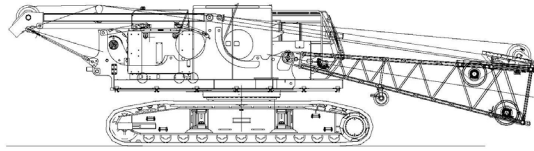

Counterweight Tray

Height	1,3 m
Length	4,4 m
Width	1,3 m
Weight	8.0 t

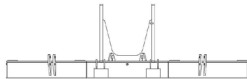
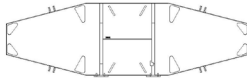

Upper Counterweight

Height	1,2 m
Length	1,5 m
Width	1,3 m
Weight	6.3 t

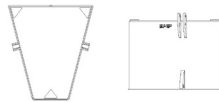

Lower Counterweight

Height	0,7 m
Length	1,8 m
Width	1,1 m
Weight	5,3 t

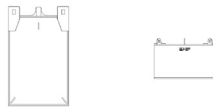

7 m No. 290 Boom Top

Height	1,5 m
Length	7,5 m
Width	1,6 m
Weight	1,5 t

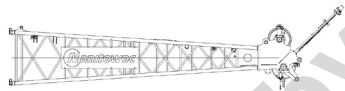

Basic Jib Assembly

Height	1,0 m
Length	10,0 m
Width	0,9 m
Weight	0,9 t



Boom Inserts

	Height	Length	Width	Weight
3 m No. 290 Boom	1,4 m	3,1 m	1,6 m	0,3 t
6 m No. 290 Boom	1,4 m	6,1 m	1,6 m	0,5 t
12 m No. 290 Boom	1,4 m	12,1 m	1,6 m	1,0 t
3 m Fixed Jib	0,6 m	3,1 m	0,8 m	0,1 t

Transportation Data

Load summary						
Item	46,0 m B10:290 Quantity on trailer load # (Does not include blocking, strapping, etc.)					
	Qty	Weight (mt)	1	2	3	4
Rotating bed w/ boom butt	1	41,5	1			
Counterweight tray	1	8,0				1
Upper counterweight	4	6,3		2	1	1
Lower counterweight	2	5,3			2	
3m No. 290 boom insert	1	0,3		1		
6m No. 290 boom insert	1	0,5				1
12m No. 290 boom insert	2	1,0		1	1	
7m No. 290 boom top	1	1,5				1
Detachable upper boom point	1	0,2		1		
82.7 Ust block	1	0,7		1		
Weight ball	1	0,3				1
Job box	1	0,4			1	
Payload for each trailer (lb)			41,5	14,7	18,1	16,6

Performance data

Front and Rear Drum Linespeed				
Single line pull mt	Single line pull/single line speed m/min			
	Layer			
	1	2	3	4
0	106	113	121	128
2,27	104	111	118	125
4,54	102	108	115	122
6,8	99	106	113	116
9,07	88	89	90	91
11,34	73	74	75	76
12,52	68	69	70	71

Third Drum Linespeed				
Single line pull mt	Single line pull/single line speed m/min			
	Layer			
	1	2	3	4
0	87	95	103	111
2,27	84	91	99	106
3,63	82	89	96	103
4,99	78	79	80	80
6,35	63	64	64	65
7,71	53	54	55	55
9,07	46	47	48	49

Front and Rear Drum Hoist Reeving	
Parts of line	Max load (kg)
1	12 520
2	25 040
3	37 560
4	50 080
5	62 600
6	75 120
7	87 640
8	100 000

Third Drum Linepull	
Parts of line	Max load (kg)
1	9 070

Drum Spooling Capacity	
Drum	Wire rope length (working)
Front and Rear	195 m
Third	143 m

Boom combinations

B10:290 boom combinations

Boom length m	Boom inserts length m		
	3,0	6,0	12,0
13	0	0	0
16	1	0	0
19	0	1	0
22	1	1	0
25	0	0	1
28	1	0	1
31	0	1	1
34	1	1	1
37	0	0	2
40	1	0	2
43	0	1	2
46	1	1	2
49	0	0	3
52	1	0	3
55	0	1	3
58	1	1	3
61	2	1	3

No. 117 fixed jib combinations

Fixed jib length m	Fixed jib inserts length m
	3,1
9,1	0
12,2	1
15,2	2
18,3	3

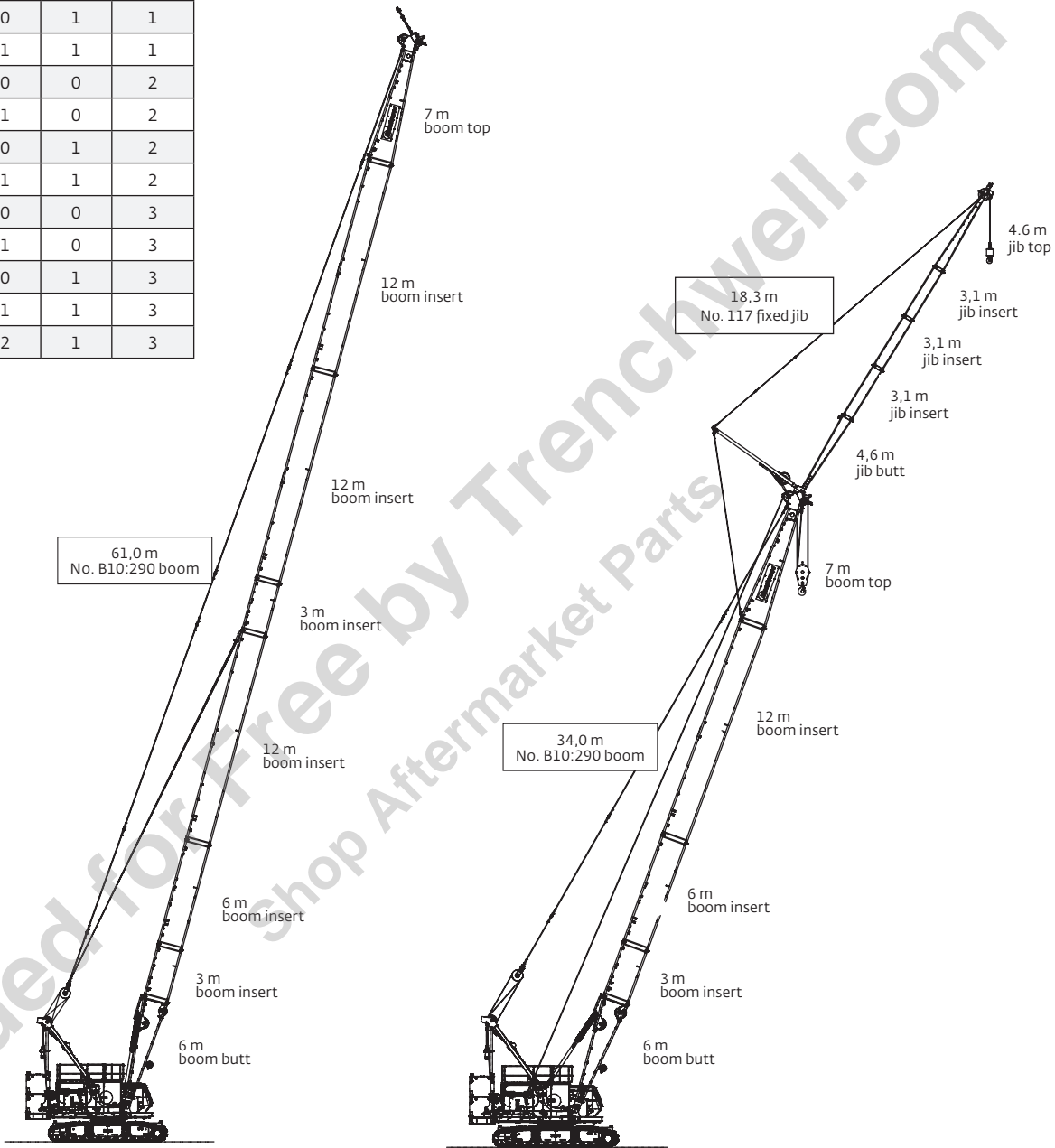

Main boom range diagram

B10:290 boom

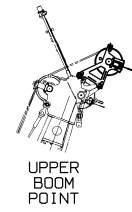
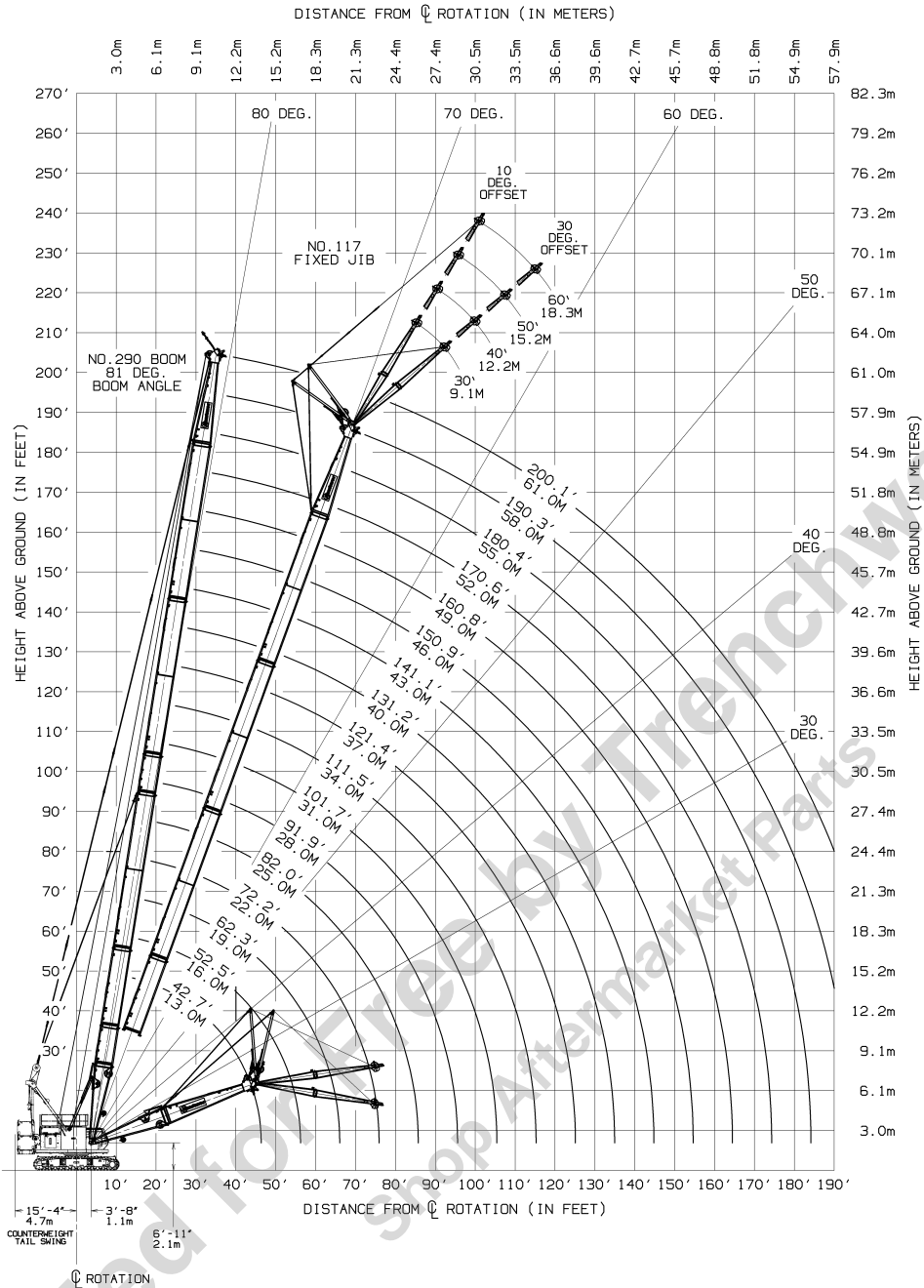

THIS CHART IS ONLY A GUIDE AND SHOULD NOT BE USED TO OPERATE THE CRANE.

The individual crane's load chart, operating instructions and other instructional plates must be read and understood prior to operating the crane

Main boom load chart

B10:290 boom
33 120 kg upper counterweight, 10 500 kg carbody counterweight

360° Radius (m)	Metric ton												
	Boom length (m)												
	13	19	25	28	31	34	37	40	43	46	49	55	61
3,7	100												
4,0	87,8												
5,0	73,5	73,3											
6,0	61,7	61,5	61,4	57,9									
7,0	49,3	49,4	49,5	49,5	49,1	47							
8,0	40,2	40,3	40,4	40,3	40,3	40,2	40,2	39,2					
9,0	34	34	34,1	34,1	34	33,9	33,9	33,8	33,5				
10,0	29,3	29,3	29,4	29,4	29,3	29,2	29,2	29,1	29	28,9	27,8		
12,0	22,6	22,8	22,9	22,9	22,8	22,7	22,6	22,6	22,5	22,4	22,3	20,1	17,2
14,0		18,5	18,6	18,6	18,5	18,4	18,3	18,3	18,2	18,1	18	17,8	16,5
16,0		15,5	15,6	15,6	15,5	15,4	15,3	15,3	15,2	15,1	15	14,8	14,6
18,0		13,2	13,3	13,3	13,2	13,1	13	13	12,9	12,8	12,7	12,5	12,2
20,0			11,5	11,5	11,4	11,3	11,2	11,2	11,1	11	10,9	10,7	10,5
21,0			10,8	10,8	10,7	10,6	10,5	10,4	10,3	10,3	10,1	10	9,7
22,0			10,1	10,1	10	9,9	9,8	9,8	9,7	9,6	9,5	9,3	9
23,0			9,5	9,5	9,4	9,3	9,2	9,2	9,1	9	8,9	8,7	8,4
24,0			9	9	8,9	8,8	8,7	8,6	8,5	8,4	8,3	8,1	7,9
25,0				8,5	8,4	8,3	8,2	8,1	8	7,9	7,8	7,6	7,4
26,0				8	7,9	7,8	7,7	7,7	7,6	7,5	7,4	7,2	6,9
27,0				7,6	7,5	7,4	7,3	7,2	7,1	7	6,9	6,7	6,5
28,0					7,1	7	6,9	6,9	6,8	6,7	6,6	6,4	6,1
29,0						6,7	6,6	6,5	6,4	6,3	6,2	6	5,7
30,0						6,3	6,2	6,2	6,1	6	5,9	5,7	5,4
32,0						5,7	5,6	5,6	5,5	5,4	5,2	5,1	4,8
34,0							5,1	5	4,9	4,8	4,7	4,5	4,3
36,0								4,6	4,5	4,4	4,3	4,1	3,8
38,0								4,2	4	4	3,8	3,7	3,4
40,0									3,7	3,6	3,5	3,3	3
42,0										3,3	3,1	3	2,7
44,0										2,9	2,8	2,7	2,4
46,0											2,5	2,4	2,1
48,0												2,1	1,9
50,0												1,9	

For complete chart, refer to www.cranelibrary.com.

THIS CHART IS ONLY A GUIDE AND SHOULD NOT BE USED TO OPERATE THE CRANE.
 The individual crane's load chart, operating instructions and other instructional plates must be read and understood prior to operating the crane

Fixed jib working range

J10:117 fixed jib on B10:290 boom

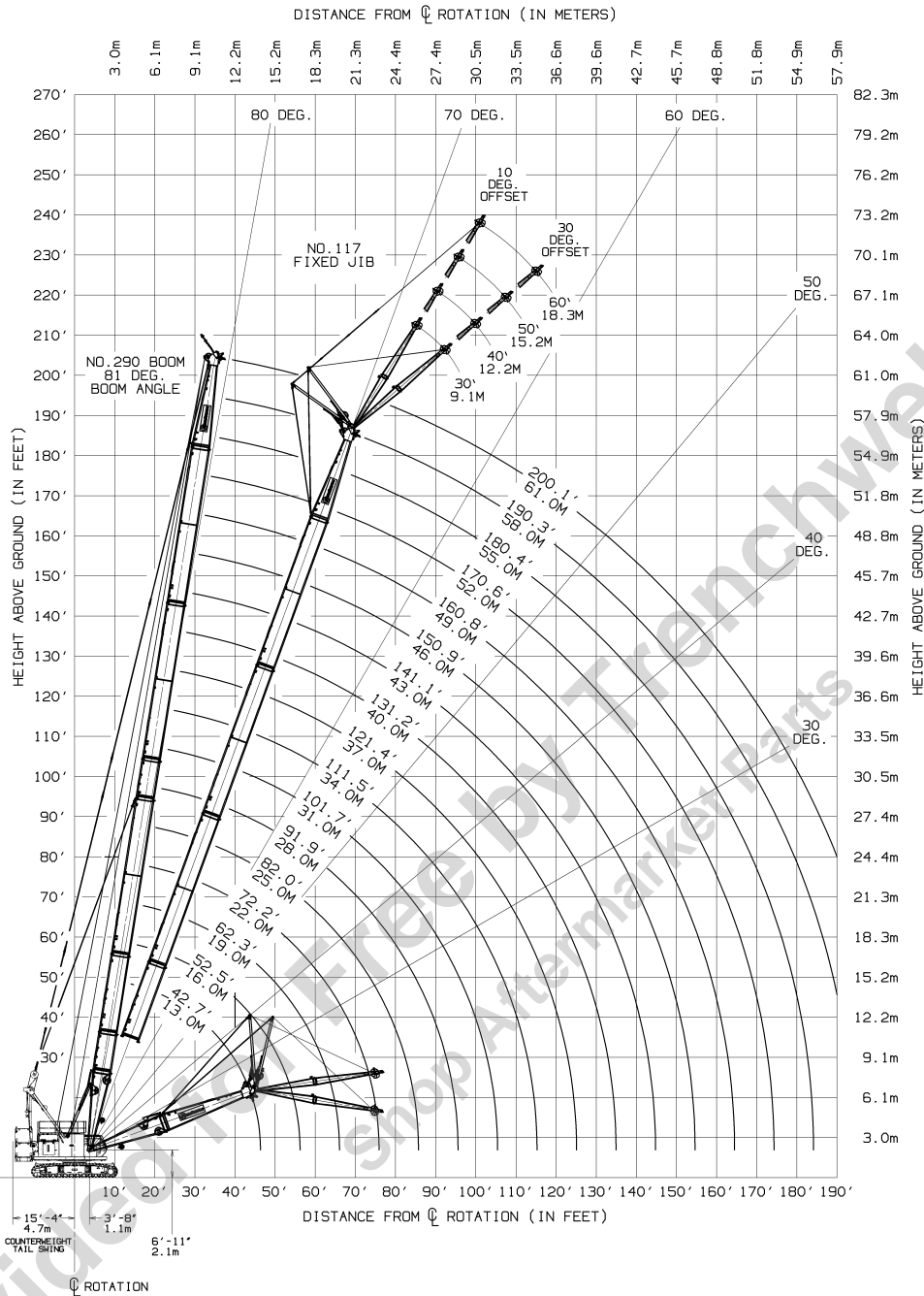

THIS CHART IS ONLY A GUIDE AND SHOULD NOT BE USED TO OPERATE THE CRANE.

The individual crane's load chart, operating instructions and other instructional plates must be read and understood prior to operating the crane

Fixed jib load chart

FJ10:117 fixed jib on B10:290 boom

33 120 kg upper counterweight, 10 500 kg carbody counterweight

360° kg x 1000

9,1 m jib at 10° offset					
Radius (m)	Boom Length (m)				
	19	28	37	46	55
8,0	12.5				
10,0	12.5	12.5			
12,0	12.5	12.5	12.5		
14,0	12.5	12.5	12.5	12.5	12.5
16,0	12.5	12.5	12.5	12.5	12.5
18,0	12.4	12.5	12.5	12.4	12.1
20,0	11.4	11.6	11.3	10.9	10.6
22,0	10.4	10.2	9.9	9.5	9.2
26,0	8.3	8.1	7.7	7.4	7.1
30,0		6.6	6.2	5.9	5.6
34,0		5.4	5.1	4.8	4.4
38,0			4.2	3.9	3.5
42,0			3.5	3.2	2.8
46,0				2.6	2.3
50,0				2.1	1.8
54,0					1.3

12,2 m jib at 10° offset					
Radius (m)	Boom Length (m)				
	19	28	37	46	55
9,1	12				
10,0	11.8				
12,0	11.4	11.7			
14,0	11.1	11.4	11.5	11.4	
16,0	10.8	11.2	11.4	11.3	11
18,0	10.6	11	11.2	11.2	10.9
20,0	10.1	10.8	11	11	10.7
22,0	9.3	10.3	10	9.7	9.4
26,0	8.1	8.2	7.9	7.6	7.2
30,0	7	6.7	6.4	6	5.7
34,0		5.5	5.2	4.9	4.6
38,0		4.6	4.3	4	3.7
42,0			3.6	3.3	3
46,0			3	2.7	2.4
50,0				2.2	1.9
54,0				1.8	1.5

15,2 m jib at 10° offset					
Radius (m)	Boom Length (m)				
	19	28	37	46	55
10,4	10.4				
12,0	10.1	10.3			
14,0	9.8	10.1	10.1		
16,0	9.5	9.8	9.9	9.8	
18,0	9.3	9.6	9.8	9.7	9.5
20,0	8.8	9.5	9.6	9.6	9.4
22,0	8	9.3	9.5	9.4	9.2
26,0	6.8	8.3	8	7.7	7.3
30,0	5.9	6.8	6.4	6.1	5.8
34,0		5.6	5.3	5	4.7
38,0		4.7	4.4	4.1	3.8
42,0		4	3.7	3.4	3
46,0			3.1	2.8	2.5
50,0			2.6	2.3	2
54,0				1.9	1.5
58,0				1.4	1.2

18,3 m jib at 10° offset					
Radius (m)	Boom Length (m)				
	19	28	37	46	55
11,0	9.3				
12,0	9.2				
14,0	8.9	9	9		
16,0	8.6	8.8	8.9	8.7	
18,0	8.3	8.6	8.7	8.6	7.9
20,0	8.1	8.4	8.5	8.5	7.8
22,0	7.3	8.3	8.4	8.4	7.7
26,0	6.1	7.9	8	7.7	7.4
30,0	5.3	6.8	6.5	6.2	5.9
34,0	4.7	5.7	5.4	5	4.7
38,0		4.8	4.5	4.1	3.8
42,0		4.1	3.7	3.4	3.1
46,0			3.2	2.8	2.5
50,0			2.7	2.3	2
54,0				1.9	1.6
58,0				1.5	1.2

THIS CHART IS ONLY A GUIDE AND SHOULD NOT BE USED TO OPERATE THE CRANE.

The individual crane's load chart, operating instructions and other instructional plates must be read and understood prior to operating the crane

Specifications

Upperworks

Engine

Cummins Model QSB6.7 Tier 4 Final (Stage IV), 6 cylinder diesel, 300 hp (223 kW) at 2100 governed RPM.

Cummins Model QSB6.7 Tier 3 (Stage III), 6 cylinder diesel, 275 hp (205 kW) at 2100 governed RPM.

Includes exhaust aftertreatment system (Tier 4 Final) or muffler (Tier 3), air cleaner, 70 amp alternator, radiator and fan. Also includes 100 gallon (378 liter) capacity diesel fuel tank, mounted on right side of upperworks.

Crane Control System

The Crane Control System (CCS) offers a user-friendly interface, two full graphic displays mounted vertically for better visibility, a jog dial for easier data input and ergonomic joysticks. Block-up limit control is standard for hoist and whip lines. Travel and swing alarms are standard. RCL/RCI (Rated Capacity Limiter/Rated Capacity Indicator) system is standard.

Hydraulic system

Three high-pressure pumps are driven by the engine. Two pumps provide “open loop” hydraulic power enabling simultaneous multi-function capability. One pump provides independent “closed loop” hydraulic power for the swing system. An additional pump provides hydraulic power for the cooler fan and an additional pump is included with free fall.

Hydraulic reservoir capacity is 83 gallon (314 liter) and is equipped with breather, sight and electrical level indicator, clean out access, and internal diffuser. Replaceable, full flow tank filters are furnished in the hydraulic circuit. All oil is filtered prior to return to the hydraulic reservoir. Hydraulic system also includes hydraulic oil cooler.

Drums

Two 22 inch width drums are driven by independent variable displacement axial piston hydraulic motors through planetary reduction. Drums are grooved for 26 mm rope and mounted in rotating bed. Powered hoisting/lowering operation is standard with automatic (spring applied, hydraulically released) multi-disc brakes, and drum rotation indicators.

- Optional: free-fall operation for front and/or rear drums.
- Optional: auxiliary (third) hydraulic powered drum mounted in rotating bed. Drum is grooved for 26 mm rope. Includes all hydraulic and electrical components to equip drum.

Boom hoist

Independent boom hoist consists of a single drum grooved for 0.75 inch diameter wire rope. Includes 0.75 inch diameter wire rope for boom hoist reeving. Drum is powered by a fixed displacement hydraulic motor coupled to an internal brake and planetary gearbox equipped with ratchet and pawl.

Gantry

The 8 part boom hoist reeving is reeved between the 5 sheave gantry and 4 sheave equalizer, with the dead end on the gantry. When used with optional self-erect sheave in the boom butt the machine is capable of installing carbody counterweights, stacking the upperworks counterweights and assembling the boom and jib. The gantry is also utilized to lift the entire upperworks counterweight assembly into place, controlled by remote control.

Specifications

Counterweight

The upperworks counterweight is attached to rotating bed with remote controlled hydraulically actuated pins. The upperworks counterweight consists of a one-piece tray and four upper counterweight boxes. Carbody counterweight boxes are each attached to carbody.

Series 1

Upper counterweight (2 pieces+tray): 20 610 kg

Series 2

Upper counterweight (4 pieces+tray): 33 120 kg

Carbody counterweight (2 pieces): 10 500 kg

Total counterweight: 43 620 kg

Swing system

Independent single swing drive mounted in rotating bed is powered by a hydraulic motor driving a spur gear through a planetary reduction with internal brake.

Maximum swing speed: 2.5 rpm.

- Optional: electronic swing position indicator and swing limiter

Operator's cab

New wider cab provides 10% increased operator legroom. Fully enclosed and galvanized steel insulated module is equipped with sliding door, large safety glass windows on all sides and roof. Signal horn, cab space heater, front and roof windshield wipers, air conditioning, dome light, sun visor and shade, fire extinguisher and air circulating fan are standard.

- Optional: External RCI light, electronic level indicator, radio and camera system.

Lowerworks

Carbody

High strength fabricated steel assembly utilizing swing away carbody beams and two hydraulic cylinders for extending and retracting of crawlers.

Crawlers

Crawler assemblies are 21' 3" (6.5 m) long, high strength steel fabrications with 3' (0.9 m) wide cast steel crawler pads. Each crawler is powered independently by a variable displacement hydraulic motor driving a planetary reduction. Crawlers provide ample tractive effort that allows counter rotation with full rated load. Maximum ground speed of 1.6 mph. (2.6 km/hr).

Attachments

No. 290 boom

The liftcrane is equipped with a 42' 8" (13 m) basic No. 290 tubular chord boom consisting of a 19' 8" (6 m) butt and 23' (7 m) top with three 25.6" (65 cm) diameter roller bearing sheaves. No. 290 boom utilizes wire rope pendants. Boom butt has incorporated equalizer rails for connecting to equalizer to boom butt, boom butt also remains installed for transportation.

Spring cushioned boom stop and electronic automatic boom stop standard.

- Optional: No. 290 boom lengths are increased using 9' 10" (3 m), 19' 8" (6 m), and 39' 4" (12 m) boom inserts with wire rope pendants. Max boom length is 200.1' (61 m).

No. 117 fixed jib

30' (9.1 m) basic No. 117 tubular chord fixed jib consisting of 15' (4.6 m) jib butt and 15' (4.6 m) jib top with 17' 11" (5.5 m) jib strut, and wire rope, pendants. Includes RCL/RCI hardware.

- Optional: No. 117 fixed jib lengths are increased using 10' (3 m) inserts with wire rope pendants. Max fixed jib length is 60' (18.3 m).

Specifications

Optional equipment

Detachable upper boom point with one 24 in diameter tapered roller bearing sheave for No. 290 boom top

Blocks and hooks –

- 13.8 USt (12.5 mT) cylindrical weight ball with swivel hook.
- 27.5 USt (25 mT) hook block with one 24 in sheaves for 26 mm wire rope with swivel hook and hook latch.
- 82.7 USt (75 mT) hook block with three 24 in sheaves for 26 mm wire rope with swivel hook and hook latch.
- 110.2 USt (100 mT) hook block with four 24 in sheaves for 26 mm wire rope with swivel hook and hook latch.

Hydraulic Test Kit: recommended to properly analyze the performance of the hydraulic system.

Service Interval Kits including the items necessary to perform general scheduled maintenance, available through Crane Care.

Special Paint Color (other than Manitowoc standard red and black.)

Special Customer Decals: custom vinyl decal(s) of name and/or logo from artwork supplied by customer.

Export Packaging: basic crane, boom and jib sections.

Provided for Free by Trenchwell.com
Shop Aftermarket Parts

Provided for Free by Trenchwell.com
Shop Aftermarket Parts

Provided for Free by Trenchwell.com
Shop Aftermarket Parts

Manitowoc Cranes

Regional headquarters

Americas

Manitowoc, Wisconsin, USA
Tel: +1 920 684 4410

Shady Grove, Pennsylvania, USA
Tel: +1 717 597 8121

Europe, Middle East, Africa

Dardilly, France - TOWERS
Tel: +33 (0)4 72 18 20 20

Wilhelmshaven, Germany - MOBILE
Tel: +49 (0) 4421 294 0

China

Shanghai, China
Tel: +86 21 6457 0066

Middle East and Greater Asia-Pacific

Singapore
Tel: +65 6264 1188

Dubai, UAE
Tel: +9714 8862677



Manitowoc
Crane Care



Manitowoc
Finance



This document is non-contractual. Constant improvement and engineering progress make it necessary that we reserve the right to make specification, equipment, and price changes without notice. Illustrations shown may include optional equipment and accessories and may not include all standard equipment.