

Grove RT540E

Service/Maintenance Manual



THIS PAGE BLANK

Reference Only

Provided for Free by Trenchwell.com

Shop Aftermarket Parts

SERVICE MANUAL

This Manual has been prepared for and is considered part of -

RT540E

Crane Model Number

This Manual is divided into the following Sections:

- SECTION 1 INTRODUCTION
- SECTION 2 HYDRAULIC SYSTEM
- SECTION 3 ELECTRIC SYSTEM
- SECTION 4 BOOM
- SECTION 5 HOIST AND COUNTERWEIGHT
- SECTION 6 SWING SYSTEM
- SECTION 7 POWER TRAIN
- SECTION 8 UNDERCARRIAGE
- SECTION 9 LUBRICATION

NOTICE

The crane serial number is the only method your distributor or the factory has of providing you with correct parts and service information.

The crane serial number is stamped on the top of the outrigger box. **Always furnish crane serial number** when ordering parts or communicating service problems with your distributor or the factory.

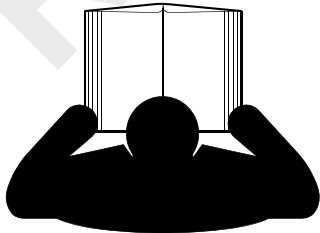
	<h2 style="text-align: center;">⚠ DANGER</h2> <p>An untrained operator subjects himself and others to death or serious injury. Do not operate this crane unless:</p> <ul style="list-style-type: none">• You are trained in the safe operation of this crane. Manitowoc is not responsible for qualifying personnel.• You read, understand, and follow the safety and operating recommendations contained in the crane manufacturer's manuals and load charts, your employer's work rules, and applicable government regulations.• You are sure that all safety signs, guards, and other safety features are in place and in proper condition.• The Operator Manual and Load Chart are in the holder provided on crane.
---	---



**CALIFORNIA
PROPOSITION 65 WARNING**

Diesel engine exhaust and some of its constituents are known to the State of California to cause cancer, birth defects, and other reproductive harm.



**CALIFORNIA
PROPOSITION 65 WARNING**

Battery posts, terminals, and related accessories contain chemical lead and lead compounds, chemicals known to the State of California to cause cancer, birth defects or other reproductive harm. Wash hands after handling.

The original language of this publication is English.

See end of this Manual for Alphabetical Index

SECTION 1 INTRODUCTION

Description 1-1
 List of Specifications 1-2
 General 1-2
 Dimensions 1-2
 Capacities 1-2
 Torque Converter/Transmission 1-2
 Engine 1-2
 Axles 1-2
 Brakes 1-2
 Wheels and Tires 1-2
 Swing Gearbox 1-2
 Boom 1-2
 Swivel Assembly 1-2
 Hydraulic Pumps 1-2
 General Maintenance 1-7
 Cleanliness 1-7
 Removal and Installation 1-7
 Disassembly and Assembly 1-7
 Pressing Parts 1-7
 Locks 1-7
 Wires and Cables 1-8
 Shims 1-8
 Bearings 1-8
 Gaskets 1-8
 Batteries 1-8
 Hydraulic Systems 1-9
 Electrical System 1-10
 Fatigue of Welded Structures 1-10
 Loctite 1-10
 Fasteners and Torque Values 1-11
 Weld Studs 1-14
 Wire Rope 1-15
 General 1-15
 Environmental Conditions 1-15
 Dynamic Shock Loads 1-15
 Lubrication 1-15
 Precautions and Recommendations During Inspection or Replacement 1-15
 Wire Rope Inspection (Running Ropes and Pendant Cables) 1-16
 Wire Rope Inspection (Boom Extension and Retraction Cables) 1-17
 Wire Rope Inspection/Replacement (All Wire Rope) 1-17
 Seizing Wire Rope 1-18
 Installing 35x7 Class Wire Rope 1-19
 Procedures for Cutting and Preparing 35x7 Class Wire Rope 1-19

SECTION 2 HYDRAULIC SYSTEM

Description 2-2
 Maintenance 2-5
 Hydraulic Oil Recommendations 2-5
 Draining and Flushing 2-5
 Removing Air from the Hydraulic System 2-6
 Parts Replacement 2-6
 Directional Control Valves 2-6
 Supply Pressure and Return Circuit 2-8

Description	2-8
Maintenance	2-9
Oil Cooler	2-13
Description	2-13
Hydraulic Pumps	2-14
Description	2-14
Maintenance	2-14
Pressure Setting Procedures	2-17
Procedure A - Checking/Setting the Main Control Valve for Hoist(s), Boom Lift and Piston Pump	2-19
Procedure B - Setting The Outrigger/Rear Steer/Oil Cooler Motor Pressures	2-19
Procedure C - Checking/Setting the Swing Directional Control Valve Work Port Relief Valves	2-20
Procedure D - Checking/Setting the Service Brake Dual Accumulator Charge Valve Charging Limits	2-20
Procedure E - Checking/Pre-Charging the Service Brake Accumulators	2-20
Procedure F - Checking/Setting the Front Steer Pressure	2-21
Procedure G - Checking/Setting the Pilot Supply Pressure	2-21
Procedure H - Checking/Setting the Swing Brake Release Pressure	2-21
Procedure J - Setting Threshold on Electronic Controllers	2-21
Valves	2-27
General	2-27
Directional Control Valves	2-30
Description	2-30
Maintenance	2-30
Accessory With Swing Directional Control Manifold	2-33
Description	2-33
Maintenance	2-33
Steering Control Valve	2-35
Description	2-35
Maintenance	2-35
Tandem Brake Valve with Treadle Pedal	2-36
Description	2-36
Maintenance	2-36
Dual Accumulator Charge Valve	2-37
Description	2-37
Maintenance	2-37
Hydraulic Accumulator Service Brake	2-39
Description	2-39
Maintenance	2-39
Holding Valves	2-40
Description	2-40
Maintenance	2-40
Cross Axle Differential Lock Valve	2-41
Description	2-41
Maintenance	2-41
Outrigger Control Manifold	2-43
Description	2-43
Maintenance	2-43
Pilot Operated Check Valve	2-44
Description	2-44
Maintenance	2-44
Integrated Outrigger/Rear Steer Manifold	2-45
Description	2-45
Maintenance	2-45
Check Valves	2-48
Description	2-48

Maintenance 2-48

Range Shift/Parking Brake Valve 2-49

 Description 2-49

 Maintenance 2-49

Axle Oscillation Lockout Valve (Standard Units) 2-50

 Description 2-50

 Maintenance 2-50

Axle Oscillation Lockout Valve (Optional CE Units) 2-52

 Description 2-52

 Maintenance 2-52

Cylinders 2-54

 General 2-54

 Maintenance 2-54

 Surface Protection for Cylinder Rods 2-54

Lift Cylinder 2-57

 Description 2-57

 Maintenance 2-57

Dual Rod Telescope Cylinder 2-60

 Description 2-60

 Maintenance 2-60

Axle Oscillation Lockout Cylinder 2-64

 Description 2-64

 Maintenance 2-64

Steer Cylinder 2-68

 Description 2-68

 Maintenance 2-68

Outrigger Extension Cylinder 2-71

 Description 2-71

 Maintenance 2-71

Outrigger Jack Cylinder 2-73

 Description 2-73

 Maintenance 2-73

SECTION 3 ELECTRIC SYSTEM

Description 3-1

 General 3-1

 Alternator 3-1

 Batteries 3-1

 Fuse Panel 3-2

 Relays 3-3

Maintenance 3-4

 General 3-4

 General Troubleshooting 3-4

 Troubleshooting Swivel-Caused Electrical Problems 3-4

 Connector Troubleshooting 3-4

 Troubleshooting Engine Starting Problems 3-5

 Troubleshooting Engine Charging Problems 3-5

 Troubleshooting Accessories 3-6

 Alternator Replacement 3-7

 Starter Replacement 3-7

 Battery Replacement 3-8

 Relay Panel Component Replacement 3-8

 Rocker Switch Replacement 3-8

 Ignition Switch Replacement 3-9

 Turn Signal Lever and Transmission Shift Lever Replacement 3-10

 Windshield Wiper Assembly Replacement 3-12

Windshield Washer Assembly Replacement 3-13
 Skylight Wiper Assembly Replacement 3-13
 Appendix A: Crane Control System (CCS) Fault Codes 3-16

SECTION 4 BOOM

Description 4-1
 Safety 4-1
 Boom System Components 4-2
 Telescope Cylinder 4-2
 Fly Section Extension Cables 4-2
 Extend Synchronizing Cable 4-2
 Fly Retraction Cables 4-2
 Outer Mid Retract Cables 4-2
 Boom Extension Sequence 4-2
 Boom Retract Sequence 4-4
 Telescope Circuit 4-4
 Description 4-4
 Theory Of Operation 4-4
 Lift Circuit 4-4
 Description 4-4
 Theory Of Operation 4-4
 General Maintenance Notes 4-5
 Swingaway Extension Removable 4-5
 Boom Removal 4-6
 Disconnect the Base Section 4-7
 Remove the Base Section 4-8
 Disconnect the Inner Mid Section 4-10
 Remove the Inner Mid Section 4-10
 Remove the Outer Mid Section 4-13
 Remove the Tele Cylinder 4-14
 Boom Nose Sheaves 4-15
 Boom Nose Sheaves Removal 4-16
 Boom Nose Sheaves Installation 4-16
 Boom Assembly Procedure 4-17
 Install Tele Cylinder 4-17
 Install the Outer Mid Section 4-20
 Install the Inner Mid Section 4-24
 Install the Base Section 4-29
 Final Boom Assembly 4-31
 Swingaway Extension Installation 4-32
 Tensioning the Boom Extend and Retract Cables 4-34
 Boom Maintenance 4-36
 Functional Test Of The Boom 4-36
 Boom Inspection 4-36
 Boom Alignment And Servicing 4-36
 Extension And Retraction Cable Maintenance 4-37
 Inspection 4-37
 Telescope Circuit Troubleshooting 4-38
 Lift Circuit Troubleshooting 4-40
 Lift Cylinder Maintenance 4-42
 Lift Cylinder Removal 4-42
 Lift Cylinder Disassembly And Assembly 4-42
 Lift Cylinder Installation 4-42

SECTION 5 HOIST AND COUNTERWEIGHT

Description 5-1
 Theory of Operation 5-1
 Maintenance 5-2
 Warm-up Procedure 5-2
 Removal 5-2
 Installation 5-3
 Functional Check 5-3
 Servicing 5-3
 Hoist Maintenance and Inspection 5-4
 Usage and Inspection 5-4
 Pre-Use or Daily Inspection 5-5
 Quarterly Inspection (every three months) 5-5
 Semi-Annual Inspections (every six months) 5-5
 Annual Inspection 5-5
 Preventive Maintenance and Oil Sampling 5-5
 Oil Change 5-5
 Gear Oil Sampling and Analysis 5-5
 Brake Test Procedure for HP15C-17G, HO30A-19G, HP35-26G Hoists 5-6
 Brake Test Procedure (To be performed with no load on the hoist) 5-6
 Hoist to Boom Alignment 5-7
 Preparation 5-7
 Tools Required 5-7
 Procedure 5-7
 Piston Motor and Control Valve 5-8
 Description 5-8
 Maintenance 5-8
 Idler Drum and Cable Follower 5-9
 Description 5-9
 Maintenance 5-9
 Hoist Drum Rotation Indicator System 5-11
 Description 5-11
 Maintenance 5-11
 Counterweight Removal 5-13

SECTION 6 SWING SYSTEM

Introduction 6-1
 Description 6-1
 Theory of Operation 6-1
 Maintenance 6-3
 Troubleshooting 6-3
 Swing Motor 6-6
 Description 6-6
 Maintenance 6-6
 Swing Gearbox And Brake 6-7
 Description 6-7
 Maintenance 6-7
 Swing Bearing 6-9
 Description 6-9
 Maintenance 6-9
 Swivels 6-14
 Description 6-14
 Hydraulic Swivel 6-16
 Electrical Swivel 6-18

T
O
C

SECTION 7..... POWER TRAIN

Engine 7-1
 Description..... 7-1
 Maintenance 7-2
 Fuel System 7-7
 Description..... 7-7
 Maintenance 7-7
 Air Intake and Exhaust System 7-9
 Description..... 7-9
 Air Intake 7-9
 Charge-Air Cooler System..... 7-13
 Muffler and Diesel Oxidation Catalyst - Tier 4 Interim 7-14
 Slip Joint Exhaust Connectors..... 7-14
 Water Cooling System 7-16
 Description..... 7-16
 Maintenance 7-16
 Test Equipment 7-19
 Antifreeze/Coolant 7-19
 Radiator Removal and Installation..... 7-19
 Drive Train 7-21
 Description..... 7-21
 Maintenance 7-21
 Transmission/Torque Converter 7-21
 Description..... 7-21
 Theory of Operation..... 7-21
 Maintenance 7-22
 Servicing the Crane After Transmission/Torque Converter Overhaul 7-25

SECTION 8..... UNDERCARRIAGE

Axles..... 8-1
 Description..... 8-1
 Maintenance 8-2
 Wheels and Tires..... 8-7
 Steering Systems 8-10
 Description..... 8-10
 Theory of Operation..... 8-10
 Maintenance 8-11
 Rear Steering System 8-12
 Hydraulic Pumps 8-13
 Front Steering Control Valve 8-13
 Integrated Outrigger/Rear Steer Manifold 8-13
 Steer Cylinders 8-14
 Rear Axle Oscillation Lockout System 8-15
 Description..... 8-15
 Axle Oscillation Lockout Cylinders..... 8-15
 Brake System..... 8-16
 Description..... 8-16
 Theory of Operation..... 8-16
 Maintenance 8-17
 Service Brakes 8-18
 Description..... 8-18
 Maintenance 8-18
 Corrosion Protection 8-22
 Parking Brake Actuator..... 8-24
 Description..... 8-24
 Maintenance 8-24

Parking Brake 8-25
 Description 8-25
 Maintenance 8-25
 Park Brake Valve 8-27
 Description 8-27
 Outriggers 8-27
 Outrigger Circuit 8-27
 Outrigger Beam 8-31
 Extension Cylinder 8-35
 Jack Cylinder 8-36
 Outrigger Control Valves 8-38

SECTION 9 LUBRICATION

General 9-1
 Environmental Protection 9-1
 Lubrication Intervals 9-1
 Arctic Conditions Below -18°C (0°F) 9-1
 Arctic Conditions Down To -40°F 9-2
 Surface Protection for Cylinder Rods 9-2
 Wire Rope Lubrication 9-3
 Lubrication Points 9-4
 CraneLUBE 9-4
 Safety 9-4
 Steering and Suspension 9-5
 Axles 9-7
 Drive Train 9-9
 Drive Train (continued) 9-11
 Outriggers 9-13
 Turntable 9-15
 Boom 9-17
 Boom (continued) 9-19
 Hoist 9-21
 Hydraulic 9-23
 Carwell® Rust Inhibitor 9-25
 Protecting Cranes From Rusting 9-25
 Cleaning Procedures 9-25
 Inspection and Repair 9-26
 Application 9-26
 Areas of Application 9-26

TOC

Reference Only

THIS PAGE BLANK

SECTION 1 INTRODUCTION

SECTION CONTENTS

Description	1-1	Batteries.....	1-8
List of Specifications	1-2	Hydraulic Systems.....	1-9
General.....	1-2	Electrical System.....	1-10
Dimensions.....	1-2	Fatigue of Welded Structures	1-10
Capacities.....	1-2	Loctite	1-10
Torque Converter/Transmission	1-2	Fasteners and Torque Values	1-11
Engine.....	1-2	Weld Studs	1-14
Axles.....	1-2	Wire Rope	1-15
Brakes.....	1-2	General	1-15
Wheels and Tires	1-2	Environmental Conditions	1-15
Swing Gearbox.....	1-2	Dynamic Shock Loads.....	1-15
Boom	1-2	Lubrication	1-15
Swivel Assembly.....	1-2	Precautions and Recommendations During Inspection or Replacement	1-15
Hydraulic Pumps.....	1-2	Wire Rope Inspection (Running Ropes and Pendant Cables)	1-16
General Maintenance	1-7	Wire Rope Inspection (Boom Extension and Retraction Cables)	1-17
Cleanliness	1-7	Wire Rope Inspection/Replacement (All Wire Rope)	1-17
Removal and Installation	1-7	Seizing Wire Rope.....	1-18
Disassembly and Assembly	1-7	Installing 35x7 Class Wire Rope	1-19
Pressing Parts	1-7	Procedures for Cutting and Preparing 35x7 Class Wire Rope	1-19
Locks	1-7		
Wires and Cables	1-8		
Shims	1-8		
Bearings	1-8		
Gaskets.....	1-8		

DESCRIPTION

This Manual provides information for the maintenance of the Model RT540E Series Grove Crane.

The lift capacities are listed on the Load Chart in the cab.

The crane incorporates an all welded parallel box construction steel frame, using planetary drive axles to provide four-wheel drive. Axle steering is accomplished utilizing hydraulic steer cylinders. The engine is mounted at the rear of the crane carrier and provides motive power through a six speed forward and reverse transmission.

The carrier frame incorporates an integral fifth wheel, to which the rear axle is mounted, to provide axle oscillation. Axle oscillation lockout is automatic when the superstructure rotates from the travel position.

The superstructure is capable of 360 degree rotation in either direction. All crane functions are controlled from the fully-enclosed cab mounted on the superstructure. The crane is equipped with a four-section, full power, sequenced and synchronized boom. Additional reach is obtained by utilizing an optional swingaway boom extension. Lifting is provided by a main hoist and an optional auxiliary hoist.

NOTE: Throughout this manual, reference is made to left, right, front, and rear when describing locations. When operating the crane, these reference locations are to be considered as those viewed from the operator seat with the superstructure facing forward over the front of the carrier frame.

NOTE: Transportation and Lifting Decal is shown in (Figure 1-1).

LIST OF SPECIFICATIONS

General

Model RT540E
 Rated Capacity See Load Chart in cab
 Drive 4 x 4
 Gross Weight .. See Axle Weight Distribution Table

Dimensions

NOTE: Dimensions listed are for a crane with all components fully retracted in the travel mode with 20.5 x 25-24 earthmover bias ply tires.

Wheelbase 3.66 m (144 in)
 Overall Crane Length 12.29 m (483.7 in)
 Overall Crane Width 2.54 m (100 in)
 Overall Crane Height 3.24 m (127 in)
 Tail-Swing 3.66 m (144 in)
 Outrigger Spread
 Retracted 2.39 m (7 ft 10 in)
 Mid Extend 4.27 m (14 ft)
 Fully Extended 6.10 m (20 ft)

Capacities

Fuel Tank 220 l (58 gal)
 Coolant System See Engine Specifications
 Lubrication System See Engine Specifications
 Hydraulic Tank (Reservoir Capacity)
 Total 442 l (117 gal)
 at Full Level 396 l (105 gal)
 at Low Level 369 l (97 gal)
 Expansion Space 46 l (12 gal)
 Hoists 5.2 l (5.5 qt)
 Swing Gearbox 4 l (4.25 qt)
 Axle Planetary Hubs 1.7 l (3.5 pt)
 Axle Differentials 9.5 l (20 pt)
 Transmission & Torque Converter 24 l (25 qt)

Torque Converter/Transmission

Stall Ratio 2.024:1
 Charge Pump Capacity 70 l/min (14.5 gpm)
 @ 2000 rpm
 Gear Ratios
 Forward/Reverse
 Lo 1st 10.07
 Lo 2nd 4.64
 Lo 3rd 2.00
 Hi 1st 4.05
 Hi 2nd 1.86
 Hi 3rd 0.80

Engine

Cummins QSB6.7

Displacement 6.7 l (409 cu in)
 Firing Order 1-5-3-6-2-4
 Lube Amount 17.5 l (18.5 qt)
 Coolant System 28.5 l (30 qt)

Axles

Total Ratio 20.06:1
 Carrier Ratio 5.57:1
 Wheel End Ratio 3.60:1

Brakes

Type Hydraulic/Split system acting on all four wheels

Wheels and Tires

Lugs 12
 Torque 461 to 488 Nm (340 - 360 lb-ft)
 Tire Size
 Standard 20.5 x 25-20 ply rating
 For roading and lifting pressures, refer to the Load Chart Book in the cab.

Swing Gearbox

Reduction Ratio 36:1
 Output Torque 6680 lb-in

Boom

Length
 Retracted 8.8 m (29 ft)
 Extended 29.0 m (95 ft)
 Power 4 Section, Full Power
 Elevation -3 to +76 degrees
 Extensions
 Fixed Offsettable 7.9 m (26 ft)
 Folding* 7.6 - 13.7 m (25 - 45 ft)
 *Extensions offsettable at 0, 15, or 30 degrees.

Swivel Assembly

Electrical 20 Slip Rings
 Hydraulic 10 ports
 Water 2 ports
 Air Conditioning 2 ports

Hydraulic Pumps

Pump #1

NOTE: Pump output is theoretical @ no-load engine speed.

Type Piston
 Sections 1
 Output - @ 275.8 bar (4,000 psi) w/no load
 Section 1 283.7 l/min (62.4 gpm)

Pump #2

Type Gear
 Sections 1
 Output - @ 172.4 bar (2,500 psi) w/no load
 Section 1 86.5 l/min (22.9 gpm)

Pump #3

Type Gear with priority flow divider
 Sections 1
 Output - @ 199.9 bar (2,900 psi) w/no load
 Section 1 57.2 l/min (15.1 gpm)

Hoists

Drum Dimensions
 Diameter 270 mm (10.63 in)
 Length (Standard) 419 mm (16.5 in)
 Cable
 Diameter 16 mm (5/8 in)
 Length-Main 137 m (450 ft)
 Length-Aux 137 m (450 ft)
 Max. Permissible Line Pull (6x36)
 51.7 kN (11,640 lb)
 Max. Single Line Speed 156.7 m/min (514 fpm)
 Hoist Motor Displacement
 Low 107 cm³ (6.53 in³) per revolution
 High 61 cm³ (3.72 in³) per revolution

TRANSPORTATION AND LIFTING DATA RT540E

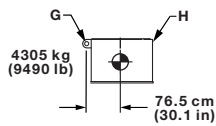
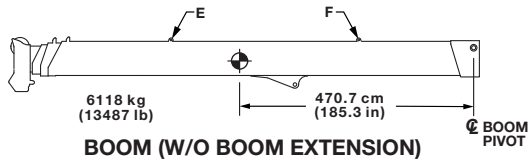

COUNTERWEIGHT (CWT)

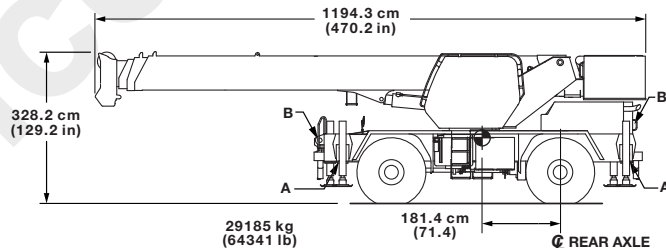
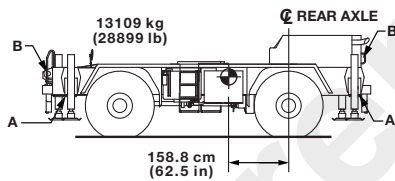
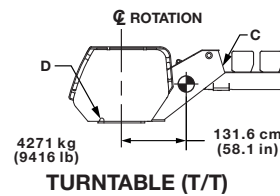
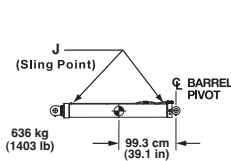

FITTINGS	NO./UNIT	TOTAL UNIT				CARRIER		LIFT CYL	T/T	BOOM	CWT	FITTING CAPACITY (TONS)						
		LIFT	TOW	TIEDOWN	LIFT	TOW	TIEDOWN					LIFT	LIFT	LIFT	LIFT	TIE DOWN		
																FORE & AFT	SIDE	DOWN
A	4	X			X							12	SEE NOTE #5					
B	4		X	X		X	X						82	25	35	7.1		
C	2							X				7.9						
D	2							X				2.3						
E	2								X			3.4						
F	2								X			3.4						
G	2									X		2.2						
H	2									X		9.4						
J	-						X					N/A						

- LIFTING OF ENTIRE CRANE OR MAJOR CRANE ASSEMBLIES MUST BE ACCOMPLISHED BY UTILIZING SPECIFIC FITTINGS INDICATED ON ABOVE CHART. USE OF FITTINGS FOR PURPOSES OTHER THAN THOSE DESIGNATED ON CHART IS PROHIBITED. FITTING CAPACITIES ARE MAXIMUM ALLOWABLE LOADS PER INDIVIDUAL FITTING.
- RIGGING PERSONNEL SHALL BE RESPONSIBLE FOR PROPER SELECTION AND PLACEMENT OF ALL SLINGS AND LOAD HANDLING DEVICES.
- DIMENSIONS AND WEIGHTS SHOWN ARE FOR HEAVIEST CONFIGURATION AVAILABLE.
- RIGGING PERSONNEL SHALL VERIFY DIMENSIONS AS REQUIRED FOR CLEARANCE.
- EXTEND OUTRIGGER BEAMS 46 CM (18 IN) AND SLING AROUND BEAMS.
- DO NOT USE PINTLE HOOKS OR CWT LUGS FOR LIFTING OR TIE DOWN OF ENTIRE CRANE.

FIGURE 1-1

**Table 1-1
Axle Weight Distribution Table**

Description	CG From Rear Axle cm (in)	Weight kg (lb)	Front Axle kg (lb)	Rear Axle kg (lb)
Basic Unit				
Maximum Axle Loads Allowed			16783 (37000)	16783 (37000)
Maximum Axle Loads Allowed while Towing			14969 (33000)	14969 (33000)
Maximum Tire Loads Allowed			15604 (34400)	15604 (34400)
Standard Carrier Assy. 4 x 4; Plus all Fluids	158.83 (62.53)	12451 (27449)	5406 (11919)	7044 (15530)
Superstructure w/Cab Plus w/Main Hoist	68.66 (27.03)	3862 (8514)	725 (1598)	3137 (6916)
Pinned on Counterweight	-119.38 (-47.00)	4305 (9490)	-1405 (-3097)	5709 (12587)
Boom Assembly; w/(2/4) Sheaves, RCL, Pivot Pins	464.82 (183.00)	5954 (13126)	7566 (16681)	-1613 (-3555)
Lift Cylinder & Lower Shaft	218.0 (85.85)	638 (1407)	381 (839)	258 (568)

Description	CG From Rear Axle cm (in)	Weight kg (lb)	Front Axle kg (lb)	Rear Axle kg (lb)
Complete Basic Machine 4 x 4 chassis; Cummins QSB 6.7 Tier 4 engine w/ transmission; front and rear axles; 20.5 x 25 tires; main hoist w/137 m (450 ft) of 5/8 in. 6 X 37 cable; full fuel and hydraulic oil	170.36 (67.07)	27209 (59986)	12674 (27940)	14536 (32046)
Add To Basic Unit Weight				
7.9 to 13.7 m (26 to 45 ft) Tele Boom Extension	616.36 (242.66)	745 (1642)	1255 (2767)	-510 (-1125)
Boom Ext. Carrier Brackets (Bolt On)	543.56 (214.00)	116 (256)	172 (380)	-56 (-124)
Auxiliary Boom Nose - Installed	1018.95 (401.16)	48 (105)	133 (293)	-85 (-188)
36 metric ton (40 ton) CE Hookblock (4 - 14 in sheaves) Stowed in Tray	396.24 (156.00)	351 (774)	381 (839)	-29 (-65)
36 metric ton (40 ton) Hookblock (3 - 14 in sheaves) Stowed in Tray	396.24 (156.00)	283 (623)	306 (675)	-24 (-52)
36 metric ton (40 ton) Hookblock (3 -12 in sheaves) Stowed in Tray	396.24 (156.00)	272 (599)	294 (649)	-23 (-50)
7 metric ton (7.5 Ton) Headache Ball (Swivel) - Attached to Front O/R Box	581.66 (229.00)	167 (369)	266 (587)	-99 (-218)
Storage Tray Mats	337.82 (133.00)	20 (43)	18 (40)	1 (3)
Rear Mounted Pintle Hook	-162.56 (-64.00)	5 (11)	-2 (-5)	7 (16)
Driver Controlled Differential Locks	177.80 (70.00)	19 (41)	9 (20)	10 (21)
Russian Certification Package	127.00 (50.00)	28 (61)	10 (21)	18 (40)
Air Conditioning - Carrier and superstructure components	38.10 (15.00)	44 (98)	5 (10)	40 (88)
360 Degree Swing Lock	205.74 (81.00)	29 (64)	16 (36)	13 (28)
Driver	187.96 (74.00)	113 (250)	58 (128)	55 (122)
CE Components - w Main Hoist	10.16 (4.00)	285 (628)	8 (17)	277 (611)
CE Components - w Main & Aux Hoists	15.24 (6.00)	274 (603)	11 (25)	262 (578)
Remove: Auxiliary Hoist Cable (453 ft) of 5/8 35 x 7	-121.92 (-48.00)	-179 (-394)	59 (131)	-238 (-525)
Remove: Main Hoist Cable (450 ft) of 5/8 6 X 37	-60.96 (-24.00)	-174 (-383)	29 (64)	-203 (-447)
Add: Aux Hoist (Replace IPO Cwt With Aux Hoist and Cable)	-109.22 (-43.00)	174 (383)	-52 (-114)	225 (497)
Sub: Optional Cable on Main Hoist (453 ft of 5/8 inch 35 X 7)	-60.96 (-24.00)	5 (11)	-1 (-2)	6 (13)
Sub: Tier 3 Engine	-157.48 (-62.00)	-17 (-37)	7 (16)	-24 (-53)
Sub: Kessler Axles	175.26 (69.00)	-86 (-190)	-41 (-91)	-45 (-99)
Sub: 16.00 X 25 Titan Tires	182.88 (72.00)	-64 (-140)	-32 (-70)	-32 (-70)

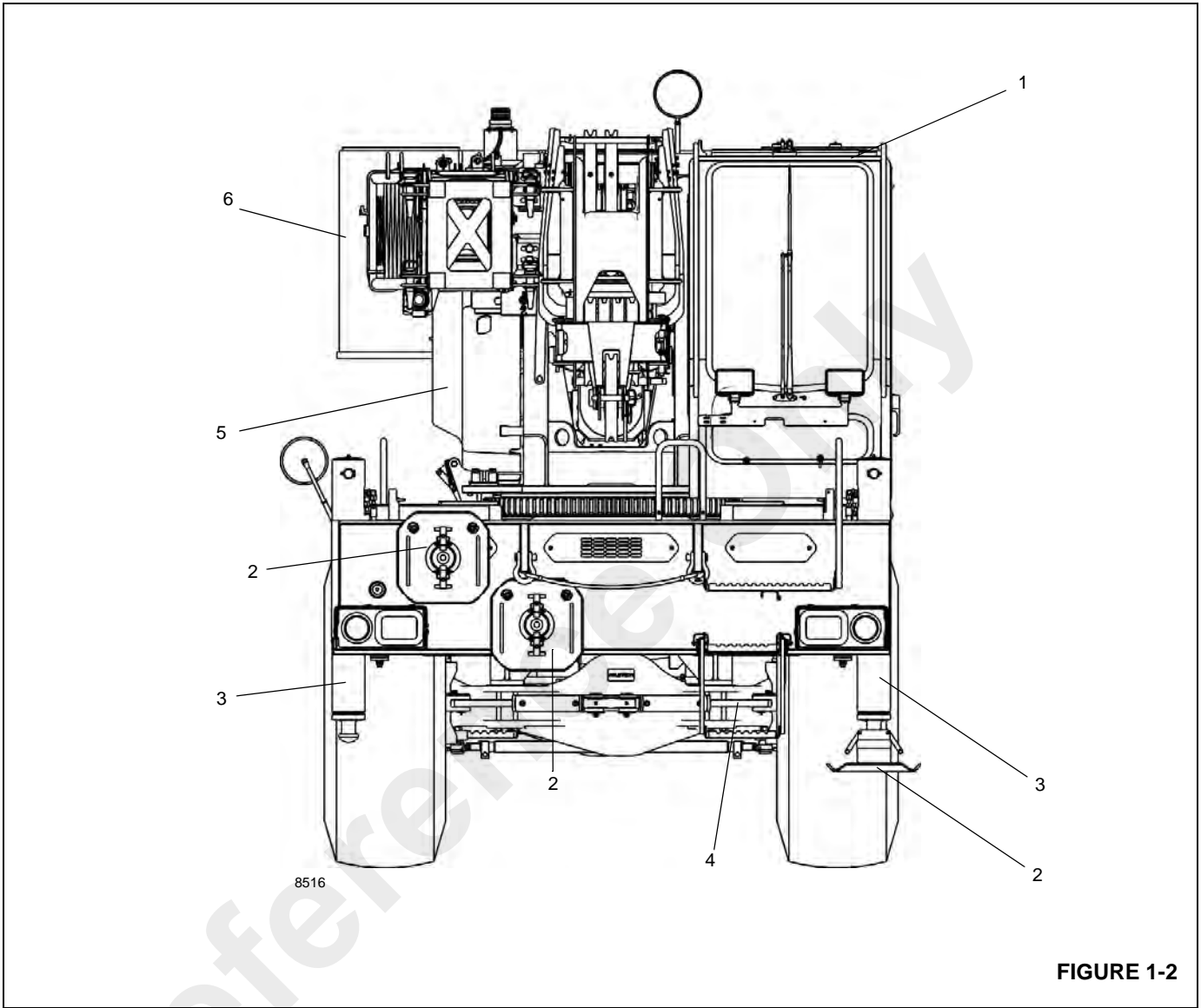

FIGURE 1-2

1	Cab	4	Steps
2	Outrigger Float	5	Valve Cover
3	Outrigger Jack Cylinder	6	Counterweight

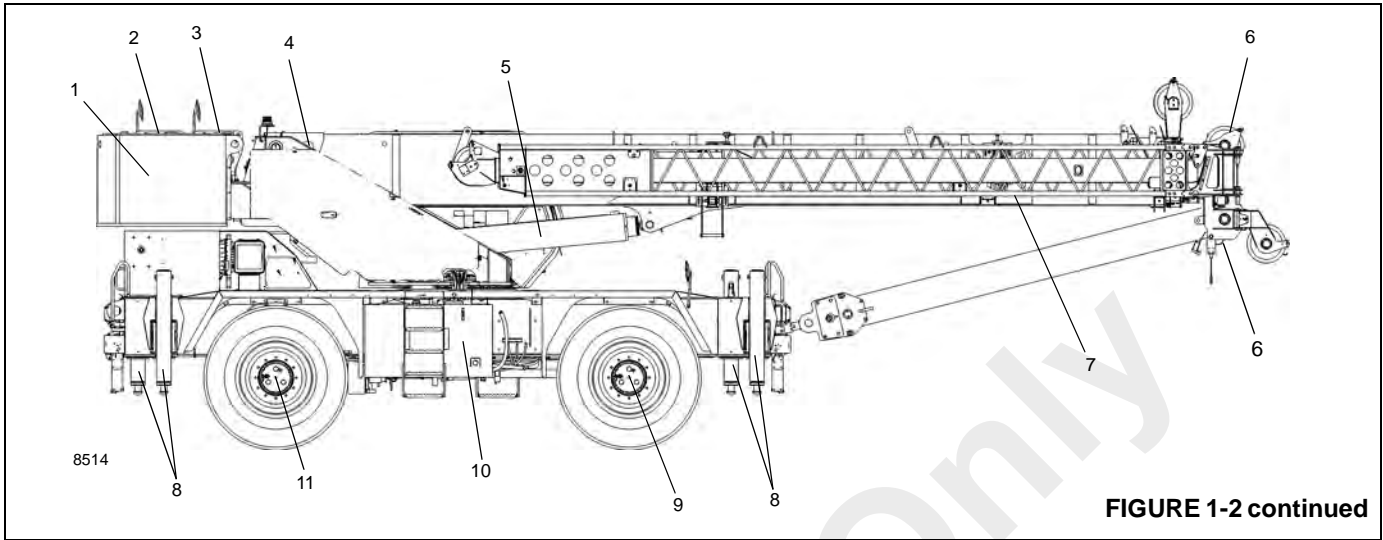

FIGURE 1-2 continued

1	Counterweight	7	Swingaway
2	Auxiliary Hoist	8	Outrigger Jack Cylinder
3	Main Hoist	9	Front Axle
4	Boom Pivot	10	Hydraulic Tank
5	Lift Cylinder	11	Rear Axle
6	Boom Nose Sheaves		

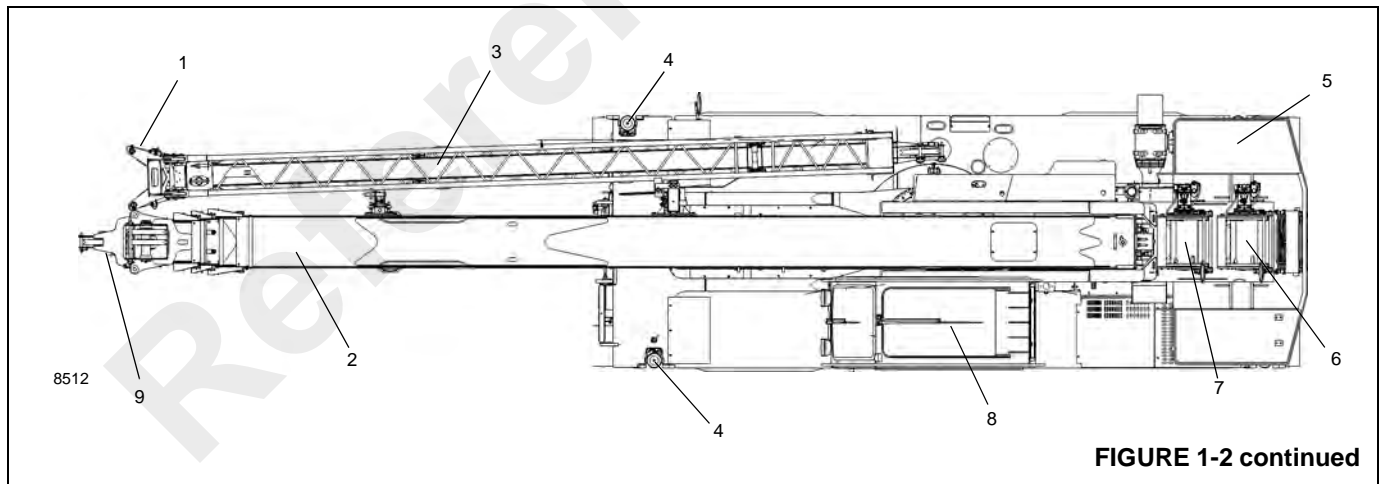

FIGURE 1-2 continued

1	Swingaway	6	Auxiliary Hoist
2	Boom	7	Main Hoist
3	Stinger	8	Cab
4	Outrigger Jack	9	Auxiliary Boom Nose
5	Counterweight		

GENERAL MAINTENANCE

These general suggestions should be helpful in following the instructions in this manual. In analyzing a system malfunction, use a systematic procedure to locate and correct the problem.

1. Determine the problem.
2. List possible causes.
3. Devise checks.
4. Conduct checks in a logical order to determine the cause.
5. Consider the remaining service life of components against the cost of parts and labor necessary to replace them.
6. Make the necessary repair.
7. Recheck to ensure that nothing has been overlooked.
8. Functionally test the failed part in its system.

NOTE: Your safety and that of others is always the number one consideration when working around machines. Safety is a matter of thoroughly understanding the job to be done and the application of good common sense. It is not just a matter of do's and don'ts. Stay clear of all moving parts.

Cleanliness

An important item in preserving the long life of the machine is keeping dirt out of working parts. Enclosed compartments, seals, and filters have been provided to keep the supply of air, fuel, and lubricants clean. It is important that these enclosures be maintained.

Whenever hydraulic, fuel, lubricating oil lines, or air lines are disconnected, clean the adjacent area as well as the point of disconnect. As soon as the disconnection is made, cap, plug, or tape each line or opening to prevent entry of foreign material. The same recommendations for cleaning and covering apply when access covers or inspection plates are removed.

Clean and inspect all parts. Be sure all passages and holes are open. Cover all parts to keep them clean. Be sure parts are clean when they are installed. Leave new parts in their containers until ready for assembly.

Clean the rust preventive compound from all machined surfaces of new parts before installing them.

Removal and Installation

When performing maintenance, do not attempt to manually lift heavy parts when hoisting equipment should be used. Never locate or leave heavy parts in an unstable position.

When raising a portion of a crane or a complete crane, ensure the crane is blocked securely and the weight is supported by blocks rather than by lifting equipment.

When using hoisting equipment, follow the hoist manufacturers recommendations and use lifting devices that will allow you to achieve the proper balance of the assemblies being lifted and to ensure safe handling. Unless otherwise specified, all removals requiring hoisting equipment should be accomplished using an adjustable lifting attachment. All supporting members (chains and cables) should be parallel to each other and as near perpendicular as possible to the top of the object being lifted.

CAUTION

The capacity of an eyebolt diminishes as the angle between the supporting members and the object becomes less than 90°. Eyebolts and brackets should never be bent and should only have stress in tension.

Some removals require the use of lifting fixtures to obtain proper balance. The weights of some components are given in their respective sections of the manual.

If a part resists removal, check to be certain all nuts and bolts have been removed and that an adjacent part is not interfering.

Disassembly and Assembly

When assembling or disassembling a component or system, complete each step in turn. Do not partially assemble one part and start assembling some other part. Make all adjustments as recommended. Always check the job after it is completed to see that nothing has been overlooked. Recheck the various adjustments by operating the machine before returning it to the job.

Pressing Parts

When pressing one part into another, use an anti-seize compound or a molybdenum disulfide base compound to lubricate the mating surfaces.

Assemble tapered parts dry. Before assembling parts with tapered splines, be sure the splines are clean, dry, and free from burrs. Position the parts together by hand to mesh the splines before applying pressure.

Parts which are fitted together with tapered splines are always very tight. If they are not tight, inspect the tapered splines and discard the part if the splines are worn.

Locks

Lockwashers, flat metal locks, or cotter pins are used to lock nuts and bolts.

Flat metal locks must be installed properly to be effective. Bend one end of the lock around the edge of the part. Bend the other end against one flat surface of the nut or bolt head.

Always use new locking devices on components which have moving parts.

When installing lockwashers on housings made of aluminum, use a flat washer between the lockwasher and the housing.

Wires and Cables

Batteries should always be disconnected prior to working on the electrical system.

When removing or disconnecting a group of wires or cables, tag each one to ensure proper identification during assembly.

Shims

When shims are removed, tie them together and identify them as to location. Keep shims clean and flat until they are reinstalled.

Bearings

Antifriction Bearings

When an anti friction bearing is removed, cover it to keep out dirt and abrasives. Wash bearings in non-flammable cleaning solution and allow them to drain dry. The bearing may be dried with compressed air BUT do not spin the bearing. Discard the bearings if the races and balls or rollers are pitted, scored, or burned. If the bearing is serviceable, coat it with oil and wrap it in clean waxed paper. Do not unwrap new bearings until time of installation. The life of an anti friction bearing will be shortened if not properly lubricated. Dirt in an anti friction bearing can cause the bearing to lock resulting in the shaft turning in the inner race or the outer race turning within the cage.

Double Row, Tapered Roller

Double row, tapered roller bearings are precision fit during manufacture and components are not interchangeable. The cups, cones, and spacers are usually etched with the same serial number and letter designator. If no letter designators are found, wire the components together to assure correct installation. Reusable bearing components should be installed in their original positions.

Heating Bearings

Bearings which require expansion for installation should be heated in oil not to exceed 121°C (250°F). When more than one part is heated to aid in assembly, they must be allowed to cool and then pressed together again. Parts often separate as they cool and contract.

Installation

Lubricate new or used bearings before installation. Bearings that are to be preloaded must have a film of oil over the entire assembly to obtain accurate pre-loading. When installing a bearing, spacer, or washer against a shoulder on a shaft, be sure the chamfered side is toward the shoulder.

When pressing bearings into a retainer or bore, uniformly apply pressure to the outer race. If the bearing is pressed on the shaft, uniformly apply pressure on the inner race.

Preload

Preload is an initial load placed on the bearing at the time of assembly. Whether a tapered roller bearing should have preload could depend on any of several conditions: rigidity of the housings and shaft, bearing spread, speed of operation, etc.

To determine whether a bearing requires preload or end clearance, consult the disassembly and assembly instructions pertaining to that bearing.

Care should be exercised in applying preload. Misapplication of preload to bearings requiring end clearance can result in bearing failure.

Sleeve Bearings

Do not install sleeve bearings with a hammer. Use a press and be sure to apply the pressure directly in line with the bore. If it is necessary to drive on a bearing, use a bearing driver or a bar with a smooth flat end. If a sleeve bearing has an oil hole, align it with the oil hole in the mating part.

Gaskets

Be sure the holes in the gaskets correspond with the lubricant passages in the mating parts. If it is necessary to make gaskets, select material of the proper type and thickness. Be sure to cut holes in the right places. Blank gaskets can cause serious damage.

When removed, always install new cylinder head and manifold gaskets using recommended gasket compound on head gaskets to allow uniform sealing.

Batteries

Clean batteries by scrubbing them with a solution of baking soda and water. Rinse with clear water. After cleaning, dry thoroughly and coat terminals and connections with an anti corrosion compound or grease.

If the machine is to be stored or not used for an extended period of time, the batteries should be removed. Store the batteries in a cool (not subfreezing), dry place, preferably on wooden shelves. Never store on concrete. A small charge should be introduced periodically to keep the specific gravity rating at recommended level.

Hydraulic Systems



DANGER

Exercise extreme care around pressurized hydraulic systems. Do not work on a hydraulic system while it is in operation or until all pressure is released.

Cleanliness

Contaminants in a hydraulic system affect operation and will result in serious damage to the system components. Dirty hydraulic systems are a major cause of component failures.

Keep the System Clean

When removing components of a hydraulic system, cover all openings on both the component and the crane.

If evidence of foreign particles is found in the hydraulic system, flush the system.

Disassemble and assemble hydraulic components on a clean surface.

Clean all metal parts in a nonflammable cleaning fluid. Then lubricate all components to aid in assembly.

Sealing Elements

Inspect all sealing elements (O-ring, gaskets, etc.) when disassembling and assembling the hydraulic system components. Installation of new elements is always recommended.

Hydraulic Lines

When installing metal tubes, tighten all bolts finger-tight. Then, in order, tighten the bolts at the rigid end, the adjustable end, and the mounting brackets. After tubes are mounted, install the hoses. Connect both ends of the hose with all bolts finger-tight. Position the hose so it does not rub the machine or another hose and has a minimum of bending and twisting. Tighten bolts in both couplings.

Due to manufacturing methods there is a natural curvature to a hydraulic hose. The hose should be installed so any bend is with this curvature.

Visual Inspection of Hoses and Fittings

CAUTION

Ensure that the hydraulic hose is depressurized before loosening the connections.

Table 1-2

Zone	Classification
A	Tropical Moist: All months average above 18°C. Latitude 15° - 25° North and South
B	Dry or Arid: Deficient precipitation most of the year. Latitude: 20° - 35° North and South
C	Moist Mid-Latitude: Temperature with mild winters. Latitude: 30° - 50° North & South
D	Moist Mid-latitude: Cold winters. Latitude 50° - 70° North & South
E	Polar: Extremely cold winters and summers. Latitude: 60° - 75° North & South

1. Visually inspect hoses and fittings once a month or every 250 hours for the following:
 - a. Leaks at hose fitting or in hose
 - b. Damaged, cut, or abraded cover
 - c. Exposed reinforcement
 - d. Kinked, crushed, flattened, or twisted hose
 - e. Hard, stiff, heat cracked, or charred hose
 - f. Blistered, soft, degraded, or loose cover
 - g. Cracked, damaged, or badly corroded fittings
 - h. Fitting slippage on hose
 - i. Other signs of significant deterioration
2. At the same service interval, visually inspect all other hydraulic components and valves for the following:
 - a. Leaking Ports
 - b. Leaking valve sections or manifolds and valves installed into cylinders or onto motors.
 - c. Damaged or missing hose clamps, guard, or shields.
 - d. Excessive dirt and debris around the hose assemblies.

If any of these conditions exist, address them appropriately.

If any of the above conditions exist, evaluate hose assemblies for correction or replacement. For replacement

3. All hydraulic hose assemblies are recommended to be replaced after 8000 hours of service life.

4. Hydraulic hose assemblies operating in a temperature climate zone "C" (Table 1-2) are recommended to be replaced after 8000 hours of service life.
5. Hydraulic hose assemblies operating in climate zones "A" and "B" (Table 1-2) with high ambient temperatures, could see hose service life reduced by 40 to 50%, therefore, it is recommended to replace these hoses after 4000 to 5000 hours of service life.
6. Hydraulic hose assemblies operating in climate zones "D" and "E" (Table 1-2) cold climates should expect a degrade of mechanical properties such as elasticity, therefore, it is recommended these hoses be inspected and addressed accordingly.

Electrical System

Connectors, Harnesses, Wires, and Connectors

Visually inspect all electrical harnesses, cables, and connectors every month or 250 hours for the following:

- Damaged, cut, blistered, or cracked insulation.
- Exposed bare wires.
- Kinked or crushed wires and cables.
- Cracked or corroded connectors, battery terminals, and ground connections.

If any the above conditions exist, evaluate and replace as necessary.

The climate in which the crane operates affects the service life of the electrical components. The climate zones are defined in (Table 1-2). Recommended replacement of harness and cables is as follows:

- Climate zone C after 10,000 hours of service.
- Climate zones A and C with high ambient temperatures and duty cycles after 8000 hours of service.
- Climate zones D and E after 10,000 hours of service.
- Salt water conditions after 8,000 hours of service.

Fatigue of Welded Structures

Experience has shown that highly stressed welded structures when repeatedly subjected to varying stresses caused by twisting, shock, bending, and intentional and/or unintentional overloads, often become subject to weld cracking which may be attributed to fatigue of the welded joint. This condition is not uncommon in construction equipment.

Equipment should be periodically inspected for evidence of weld fatigue. The frequency of these inspections should be commensurate with the age of the equipment, the severity of

the application, and the experience of the operators and maintenance personnel. The following are known high stress areas applicable to Manitowoc/Grove machines, and a visual inspection of these areas should be made part of an owner's planned preventive maintenance program:

1. Power Telescope Boom - wear pad retaining structures, hydraulic cylinder attaching points, boom pivot shaft retaining structures.
2. Outrigger pads, beams, boxes and attachment structures.
3. Main frames - generally in the area of doubler plates and crossmembers; at the junction of front and rear frame members on truck cranes.
4. Turntable bearing connection (where bearing is welded to the crane superstructure or chassis).
5. Counterweight support structures.
6. Chassis axle and suspension mounting structures.
7. Hydraulic cylinder end connections.

The above is provided only as a guide, and your inspection plan should not be limited to the areas listed. A thorough visual inspection of all weldments is good practice.

Anyone requiring more detailed inspection instructions and/or repair procedures may request them by contacting the local Manitowoc/Grove distributor.

Loctite



DANGER

Loctite type adhesives contain chemicals that may be harmful if misused. Read and follow the instructions on the container.

Always follow the directions on the Loctite container as not all Loctite types are suitable for all applications. Various types of Loctite are specified throughout the Service Manual. The following types of Loctite brand adhesives are available from the Parts Department of the local Manitowoc/Grove distributor.

Application of Medium Strength Loctite

NOTE: The fastener may be re-used; the adhesive may be re-applied over cured adhesive residue.

The following procedure covers the proper application and curing method for medium strength Loctite adhesive/sealant (Loctite #243) and primer (Loctite Primer T7471).

Primer Application

NOTE: It is not necessary to bathe the threads in primer.

1. Ensure the threaded surface, both male and female, is clean and free of dirt and oil. Apply a light spray coating of primer to both male and female parts to be joined to clean and accelerate the curing process.
2. Allow the part to dry prior to adhesive/sealant application.

Adhesive/Sealant Application

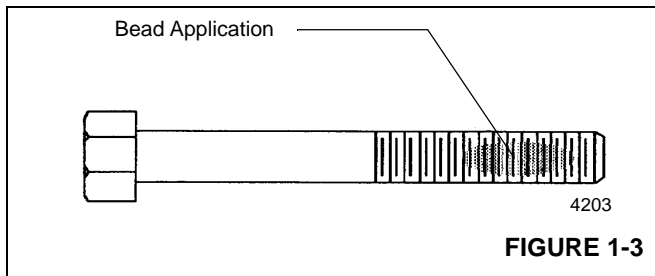

1. Apply a bead perpendicular to the thread, several threads wide, in the approximate area of threaded engagement (Figure 1-3).
2. In a blind hole application, a bead of several drops of adhesive should be applied into the bottom of the hole to be hydraulically forced up during engagement.
3. After application and engagement of mated threads, fixturing will occur within five (5) minutes if primed prior to engagement. Fixturing may take up to 30 minutes on unprimed parts.
4. Time required to achieve full strength is 24 hours. Maximum ultimate strength is achieved using no primer with this specific threadlocking adhesive.

Fasteners and Torque Values

Use bolts of the correct length. A bolt which is too long may bottom before the head is tight against the part it is to hold. If a bolt is too short, there may not be enough threads engaged to hold the part securely. Threads can be damaged. Inspect them and replace fasteners, as necessary.

Torque values should correspond to the type bolts, studs, and nuts being used.

The torque tables are provided by Manitowoc for reference when performing maintenance.

Use of proper torque values is extremely important. Improper torquing can seriously affect performance and reliability.

Identification of fastener grade is always necessary. When marked as a high strength bolt (grade 5, 8, etc.), the mechanic must be aware that he/she is working with a highly stressed component and the fastener should be torqued accordingly.

NOTE: Some special applications require variation from standard torque values. Reference should always

be made to component overhaul procedures for recommendations.

Special attention should be given to the existence of lubricant, plating, or other factors that might require variation from standard torque values.

The use of lubricants on zinc-flake coated parts shall be prohibited since this will change the required torque value.

When maximum recommended torque values have been exceeded, the fastener should be replaced.

Previously installed bolts and nuts of Grade 8 or Class 10.9 and higher may not be reused.

When referring to the applicable torque charts, use values as close as possible to the torque values shown to allow for wrench calibration tolerance.

Torque Wrenches

Flexible beam type wrenches, even though they might have a pre-set feature, must be pulled at right angle and the force must be applied at the center of the handle. Force value readings must be made while the tool is in motion. Rigid handle type, with torque limiting devices that can be pre-set to required values, eliminate dial readings and provide more reliable, less variable readings.

NOTE: If multipliers and/or special tools are used to reach hard to get at areas, ensure torque readings are accurate.

Torque wrenches are precision instruments and must be handled with care. To ensure accuracy, calibrations must be made on a scheduled basis. Whenever there is a possibility that a torque wrench may have been either overstressed or damaged, it should immediately be removed from service until recalibrated. When using a torque wrench, any erratic or jerking motion can result in the application of excessive or improper torque. ALWAYS use a slow, even movement and STOP when the predetermined value has been reached.

When using step wrenches, calculated wrench settings are valid only when the following conditions are met:

- Torque wrenches must be those specified and forces must be applied at the handle grip. The use of handle extensions will change applied torque to the bolt.
- All handles must be parallel to the step wrench during final tightening. Multiplier reaction bars may be misaligned no more than 30 degrees without causing serious error in torque.
- Multiplier bar handles must be propped or supported within the outer 1/4 of the handle length, or serious under or over tightening will occur.

To convert pounds-foot (lb-ft) of torque to newton meters (Nm), multiply the pounds-foot quantity by 1.3558.

To convert pounds-inch (lb-in) of torque to Newton meters (Nm), multiply the pounds-inch quantity by 0.11298.

Torque Values

The following tables list the torque values for both ASME standard and metric fasteners. The tables list the values for grade 5 and grade 8 zinc-flake coated, untreated (black) finish and stainless steel fasteners.

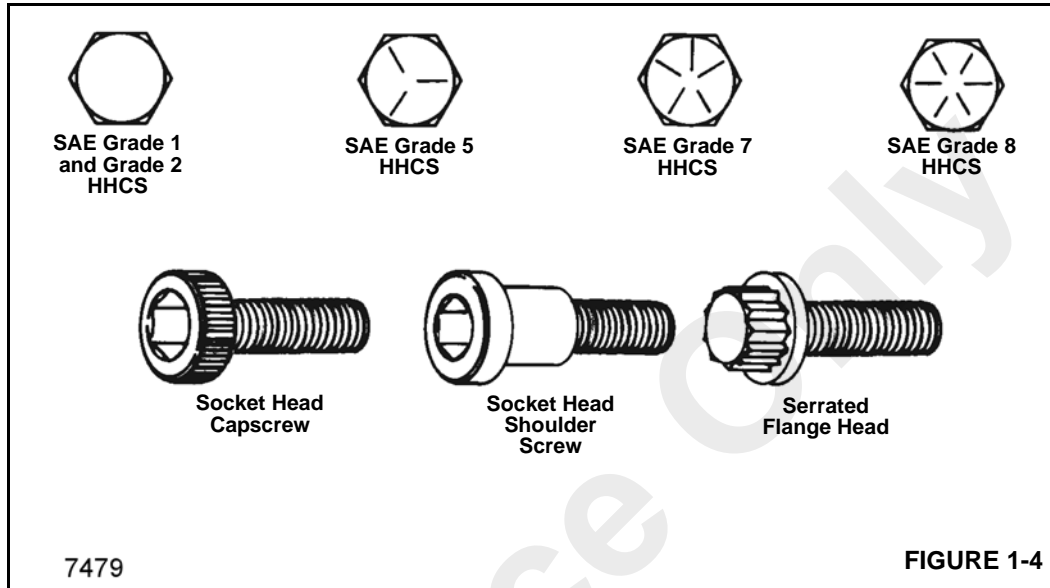

Table 1-3: UNC (Coarse) Thread: Torque Values for Zinc-Flake Coated and Untreated Fasteners

		Bolt Diameter - Inches													
		Torque Values (Pounds-Foot, Maximum/Minimum)													
	SAE Grade	1/4	5/16	3/8	7/16	1/2	9/16	5/8	3/4	7/8	1	1-1/8	1-1/4	1-1/2	
Zinc-Flake	5	7	14	25	40	61	88	121	213	342	512	636	884	1532	
	8	10	20	36	57	86	124	171	301	483	723	1032	1433	2488	
Untreated	5	9.0	19	32	52	78	114	156	270	416	606	813	1141	2028	
		7.7	17	30	48	72	106	144	249	384	560	751	1053	1865	
	8	12.5	26	48	73	120	161	234	385	615	929	1342	2043	3276	
		11.5	24	44	67	110	143	216	355	567	857	1234	1885	3024	

NOTE: Studs shall be torqued using capscrew values when grade is known.

Table 1-4: UNF (Fine) Thread: Torque Values for Zinc-Flake Coated and Untreated Fasteners

		Bolt Diameter - Inches													
		Torque Values (Pounds-Foot, Maximum/Minimum)													
	SAE Grade	1/4	5/16	3/8	7/16	1/2	9/16	5/8	3/4	7/8	1	1-1/8	1-1/4	1-1/2	
Zinc-Flake	5	8	15	28	44	66	95	132	229	364	543	785	944	1654	
	8	11	22	39	61	94	134	186	323	514	766	1109	1530	2682	
Untreated	5	10	21	36	57	88	126	182	312	458	658	882	1251	2288	
		9	19	34	53	81	116	167	287	421	606	814	1155	2105	
	8	14.5	26	53	85	125	177	250	425	672	1009	1500	2092	3640	
		13.5	24	49	79	115	163	230	393	620	931	1380	1925	3360	

NOTE: Studs shall be torqued using capscrew values when grade is known.

Table 1-5: Metric Fasteners, Coarse Thread, Zinc-Flake Coating

Bolt Diameter - Metric																
Torque Values (Nm)																
Class	M4	M5	M6	M8	M10	M12	M14	M16	M18	M20	M22	M24	M27	M30	M33	M36
8.8	2.6	5.2	9.0	21.6	42.4	73.1	116	178	250	349	467	600	877	1195	1608	2072
10.9	3.7	7.5	12.5	31.5	62.0	110	170	265	365	520	700	900	1325	1800	2450	3150
12.9	4.3	9.0	15.0	36.0	75.0	128	205	315	435	615	830	1060	1550	2125	2850	3700

Table 1-6: Metric Fasteners, Coarse Thread, Untreated

Bolt Diameter - Metric																
Torque Values (Nm, Maximum/Minimum)																
Class	M4	M5	M6	M7	M8	M10	M12	M14	M16	M18	M20	M22	M24	M27	M30	
8.8	3.1	6.5	11	19	27	53	93	148	230	319	447	608	774	1134	1538	
	2.8	5.9	10	17	25	49	85	136	212	294	413	562	714	1046	1420	
10.9	4.5	9.2	16	26	38	75	130	212	322	455	629	856	1089	1591	2163	
	4.1	8.5	14	24	35	69	120	195	298	418	581	790	1005	1469	1997	
12.9	5.4	11	19	31	45	89	156	248	387	532	756	1029	1306	1910	2595	
	4.9	10	17	28	42	83	144	228	357	490	698	949	1206	1763	2395	

Table 1-7: Metric Fasteners, Fine Thread, Zinc-Flake Coating

Bolt Diameter - Metric														
Torque Values (Nm)														
Class	M8x1	M10x1	M10x1.25	M12x1.5	M14x1.5	M16x1.5	M18x1.5	M20x1.5	M22x1.5	M24x2	M27x2	M30x2	M33x2	M36x3
8.8	23	46	44	75	123	185	270	374	496	635	922	1279	1707	2299
10.9	34	71	66	113	188	285	415	575	770	980	1425	2025	2500	3590
12.9	41	84	79	135	220	335	485	675	900	1145	1675	2375	2900	4200

Table 1-8: Metric Fasteners, Fine Thread, Untreated

Bolt Diameter - Metric														
Torque Values (Nm, Maximum/Minimum)														
Class	M8x1	M10x1	M10x1.25	M12x1.5	M14x1.5	M16x1.5	M18x1.5	M20x1.5	M22x1.5	M24x2	M27x2	M30x2	M33x2	M36x3
8.8	29	57	57	100	160	248	345	483	657	836	1225	1661	—	—
	27	53	53	92	147	229	318	446	607	771	1130	1534	—	—
10.9	41	81	81	1140	229	348	491	679	924	1176	1718	2336	—	—
	38	75	75	130	211	322	451	627	853	1085	1587	2157	—	—
12.9	49	96	96	168	268	418	575	816	1111	1410	2063	2800	—	—
	45	90	90	156	246	386	529	754	1025	1302	1904	2590	—	—

Table 1-9: UNC (Coarse) Thread: Torque Values for Stainless Steel Fasteners with Oil Lubrication

Size	Torque Value	
	lb-in	lb-ft
#5 (0.125)	6.9	—
#8 (0.164)	18	—
#10 (0.190)	21	—
1/4	68	—
5/16	120	10
3/8	210	17.5
7/16	340	28
1/2	—	39
5/8	—	74
3/4	—	114

NOTE: Stainless steel fasteners tend to gall while being tightened. To reduce this risk, lubricate the threads with oil or molybdenum disulfide and torque at low speeds without interruptions. Do not use excessive pressure. Impact wrenches are not recommended.

Table 1-10: Metric Coarse Thread: Torque Values for Stainless Steel Fasteners with Oil Lubrication

Size	Torque Value
	Nm
M2.5	0.4
M3	0.9
M4	1.5
M5	3.1
M6	5.3
M8	13.0
M10	27.0
M12	45.0
M14	71.1
M16	109
M18	157
M20	220

NOTE: Stainless steel fasteners tend to gall while being tightened. To reduce this risk, lubricate the threads with oil or molybdenum disulfide and torque at low speeds without interruptions. Do not use excessive pressure. Impact wrenches are not recommended.

Weld Studs

Unless otherwise specified the following grade 2 torque values ($\pm 10\%$) apply.

Table 1-11: Weld Stud Torque Values

STUD SIZE	TORQUE
#10	20 lb in
1/4"	4 lb ft
5/16"-18	9 lb ft
5/16"-24	10 lb ft
3/8"	14 lb ft
1/2"	35 lb ft
5/8"	70 lb ft

T-2-4

WIRE ROPE

General

The following information is a compendium of information from various wire rope manufacturers and includes inspection, replacement, and maintenance guidelines for wire rope as established by ANSI/ASME B30.5, federal regulations, and Manitowoc. The inspection interval shall be determined by a qualified person and shall be based on such factors as expected rope life as determined by experience on the particular installation or similar installations, severity of environment, percentage of capacity lifts, frequency rates of operation, and exposure to shock loads. Periodic inspections need not be at equal calendar intervals and should be performed at shorter time intervals as the wire rope approaches the end of its useful life. A periodic inspection shall be performed at least once a year. The following provides inspection and maintenance procedures for wire ropes used on Grove products (e.g. wire rope used as load lines [hoisting cables], boom extension and retraction cables, pendant cables, tow winch cables, and hook block tie down cables).

Environmental Conditions

The life expectancy of wire rope may vary due to the degree of environmental hostility and other conditions to which these mechanical devices are subjected. Variation in temperature, continuous excessive moisture levels, exposure to corrosive chemicals or vapors or subjecting the wire rope to abrasive material may shorten normal wire rope life. Frequent/periodic inspections and maintenance of your wire rope is recommended for preventing premature wear and to insure long-term satisfactory performance.

Dynamic Shock Loads

Subjecting wire rope to abnormal loads beyond the endurance limit will shorten the wire ropes, life expectancy. Examples of this type of loading are listed below.

1. High velocity movement e.g.; hoisting or swinging of a load followed by abrupt stops.
2. Suspending loads while traveling over irregular surfaces such as railroad tracks, potholes, and rough terrain.
3. Moving a load that is beyond the rated capacity of the lifting mechanism, i.e.; overloading.

Lubrication

A wire rope cannot be lubricated sufficiently during manufacture to last its entire life. Therefore, new lubricant must be added throughout the life of a rope to replace factory lubricant which is used or lost. It is important that lubricant applied as part of a maintenance program shall be compatible with the original lubricant, and to this end, the rope manufacturer should be consulted. Lubricant applied

shall be of the type which does not hinder visual inspection. Those sections of rope which are located over sheaves or otherwise hidden during inspection and maintenance procedures require special attention when lubricating rope. The object of rope lubrication is to reduce internal friction and to prevent corrosion.

During fabrication, ropes receive lubrication; the kind and amount depends on the rope's size, type, and anticipated use. This in-process treatment will provide the finished rope with ample protection for a reasonable time if it is stored under proper conditions. But, when the rope is put into service, the initial lubrication may be less than needed for the full useful life of the rope. Because of this possibility, periodic applications of a suitable rope lubricant are necessary.

The following are important characteristics of a good wire rope lubricant:

1. It should be free from acids and alkalis.
2. It should have sufficient adhesive strength to remain on the ropes.
3. It should be of a viscosity capable of penetrating the interstices between wires and strands.
4. It should not be soluble in the medium surrounding it under the actual operating conditions (i.e. water).
5. It should have a high film strength.
6. It should resist oxidation.

Before applying lubrication, accumulations of dirt or other abrasive material should be removed from the rope. Cleaning can be accomplished by using a stiff wire brush and solvent, compressed air, or live steam. Immediately after the wire rope is cleaned, it should be lubricated. Many techniques may be used; these include bath, dripping, pouring, swabbing, painting or pressure spray methods. Whenever possible, the lubricant should be applied at the top of a bend in the rope, because at that point the strands are spread by bending and are more easily penetrated. There should be no load on the rope while it is being lubricated. It should be noted, the service life of wire rope will be directly proportional to the effectiveness of the method used and amount of lubricant reaching the working parts of the rope.

Precautions and Recommendations During Inspection or Replacement

1. Always lock out equipment power when removing or installing wire rope assemblies.
2. Always use safety glasses for eye protection.
3. Wear protective clothing, gloves, and safety shoes as appropriate.
4. Use supports and clamps to prevent uncontrolled movement of wire rope, parts, and equipment.

5. When replacing fixed length cable assemblies (e.g. pendants) having permanently attached end fittings use only pre-assembled lengths of wire rope as supplied from Manitowoc. Do not build lengths from individual components.
6. Replace an entire wire rope assembly. Do not attempt to rework damaged wire rope or wire rope ends.
7. Never electroplate wire rope assemblies.
8. Do not weld any wire rope assembly or component unless welding is recommended by the wire rope manufacturer. Welding spatter shall never be allowed to come in contact with the wire rope or wire rope ends. In addition, be sure that the wire rope is not an electrical path during other welding operations.
9. Wire ropes are manufactured from special steels. If heating a wire rope assembly is absolutely necessary for removal, the entire wire rope assembly shall be discarded.
10. On systems equipped with two or more wire rope assemblies operating as a matched set, they shall be replaced as an entire set.
11. Do not paint or coat wire ropes with any substance except approved lubricants.
12. Measure the rope's diameter across crowns (1) of the strands when determining if rope has become damaged (Figure 1-5).

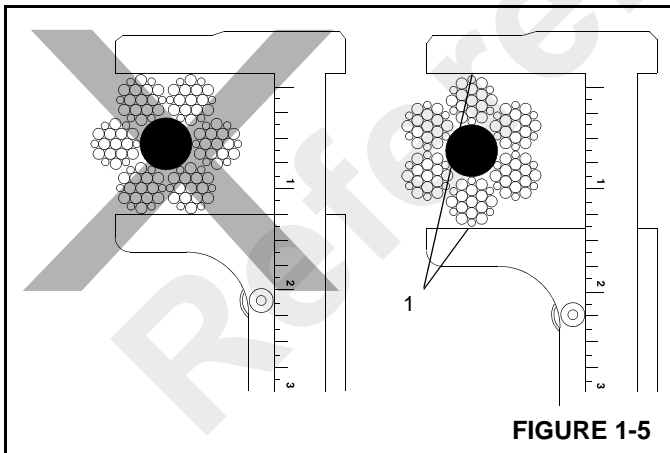
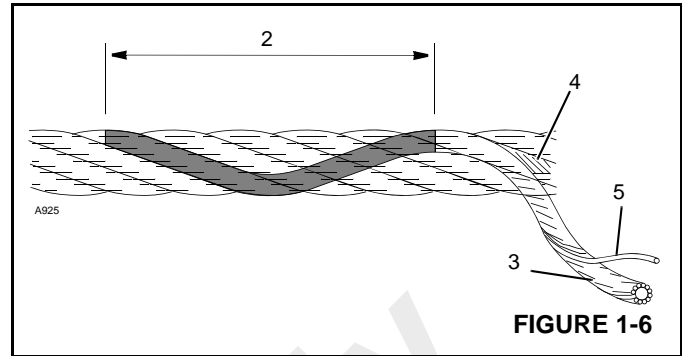

FIGURE 1-5

13. When checking for broken wires (5) (Figure 1-6) relax the rope, move it off "pick-up points", and flex it as much as possible. Use a sharp awl to pick and probe between wires and strands, lifting any wire which appears loose or moves excessively. Defect in the rope is spoke of in relations to "Lay Length" (2) which is the distance measured along rope in which one strand (3) makes one complete revolution around core (4).



Wire Rope Inspection (Running Ropes and Pendant Cables)

Wire rope should be inspected frequently/daily and periodically/yearly in accordance with the following information excerpted from a National Consensus Standard as referenced by Federal Government Agencies. Recommended inspection intervals may vary from machine to machine and may vary based on environmental conditions, frequency of lifts, and exposure to shock loads. The inspection time intervals may also be predetermined by state and local regulatory agencies.

NOTE: Wire rope may be purchased through Manitowoc Crane Care.

Any deterioration observed in the wire rope should be noted in the equipment inspection log and an assessment concerning wire rope replacement should be made by a qualified person.

Keeping Records

A signed and dated report of the wire rope's condition at each periodic inspection must be kept on file at all times. The report must cover all inspection points listed in this section. The information in the records can then be used to establish data which can be used to determine when a wire rope should be replaced.

It is recommended that the wire rope inspection program include reports on the examination of wire rope removed from service. This information can be used to establish a relationship between visual inspection and the rope's actual internal condition at the time of removal from service.

Frequent Inspection

A frequent daily visual inspection is recommended for all running ropes in service. This inspection should be made on all wire rope which can be expected to be in use during the day's operation. This inspection should be used to monitor progressive degradation and to discover severe damages necessitating wire rope replacement such as:

1. Distortion, Kinking, Crushing, Un-stranding, Bird caging, Reduction of diameter, etc.
2. General corrosion.
3. Broken or cut strands.
4. Number, distribution and type of broken wires.
5. Evidence of core failure.
6. End fitting wear/abrasion.

Pay particular attention to areas of the rope where wear and other damage is likely to occur:

1. **Pick-up Points:** Sections of wire rope that are repeatedly stressed during each lift, such as those sections in contact with sheaves.
2. **End Attachments:** The point where a fitting is attached to the wire rope or the point where the wire rope is attached to the drum.
3. **Abuse Points:** The point where the wire rope is subjected to abnormal scuffing and scraping.

Periodic Inspection

Wire rope should be inspected periodically/annually or at a shorter time interval if necessitated by environmental or other adverse conditions, and shall cover the entire length of the wire rope. Only the outer surface of the wire rope need be inspected, and no attempt should be made to open the rope. Periodic inspection should include all items listed under frequent inspection plus the following:

1. Inspect for reduction of rope diameter below nominal diameter.
2. Inspect for severely corroded or broken wires at end connections.
3. Inspect for severely corroded, cracked, bent, worn, or improperly applied end connections.
4. Inspect wire rope in areas subjected to rapid deterioration such as:
 - Sections in contact with saddles, equalizer sheaves, or other sheaves where wire rope travel is limited.
 - Sections of wire rope at or near terminal ends where corroded or broken wires may protrude.
5. Inspect boom nose sheaves, hook block sheaves, boom extension/jib sheaves, auxiliary boom nose sheaves, and hoist drums for wear. Damaged sheaves or hoist

drums can accelerate wear and cause rapid deterioration of the wire rope.

Wire Rope Inspection (Boom Extension and Retraction Cables)

Periodic Inspection.

It is recommended that a weekly inspection of all boom extension and retraction cables be performed using the following guidelines. The inspection shall cover all visible areas of the extension and retraction cables of an assembled boom. Note that extending and/or retracting the boom may be required to access visual inspection holes.

The inspection shall cover the entire length of the extension and retraction cables of a disassembled boom prior to reassembly. This inspection should be used to monitor progressive degradation and to discover severe damages necessitating wire rope replacement or equipment repair. Inspection criteria are as follows:

1. Inspect for reduction of rope diameter below nominal diameter.
2. Inspect for severely corroded or broken wires at end connections.
3. Inspect for severely corroded, cracked, bent, worn, or improperly applied end connections.
4. Inspect wire rope in areas subjected to rapid deterioration such as:
 - Sections in contact with saddles, equalizer sheaves, or other sheaves where wire rope travel is limited.
 - Sections of wire rope at or near terminal ends where corroded or broken wires may protrude.
 - Sections of wire rope in contact with stationary surfaces where abrasion or chafing may take place as a result of equipment vibration.
5. Inspect for damaged or wobbly boom extension and retraction sheaves that may cause rapid deterioration of the wire rope.
6. Inspect for unusual cable sag/stretch and be sure cables used in sets all have an equal tension applied. Repeated need for adjustment of an individual cable is evidence of cable stretch and indicates the need for additional and more thorough inspection in order to determine and correct the cause.

Wire Rope Inspection/Replacement (All Wire Rope)

No precise rules can be given for determination of the exact time for replacement of wire rope since many variable factors are involved. Determination regarding continued use or replacement of wire rope depends largely upon the good judgment of an appointed and qualified person who evaluates the remaining strength in a used rope after allowance for any deterioration disclosed by inspection.

Wire rope replacement should be determined by the following information excerpted from a National Consensus Standard as referenced by Federal Government Agencies and as recommended by Grove Worldwide. All wire rope will eventually deteriorate to a point where it is no longer usable. Wire rope shall be taken out of service when any of the following conditions exist:

- Kinking, crushing, birdcaging, or any other damage resulting in distortion of the rope structure.
- Evidence of any heat damage from any cause.
- Reductions from nominal diameter of more than 5%.
- In running ropes, six randomly distributed broken wires in one lay or three broken wires in one strand in one lay.
- In standing ropes, more than two broken wires in one lay in sections beyond end connections or more than one broken wire at an end connection.
- In rotation resistant rope, two randomly distributed broken wires in six rope diameters or four randomly distributed broken wires in 30 rope diameters.
- Severe corrosion as evidenced by pitting.
- Manitowoc recommends that for cable extended booms, a single damaged wire rope assembly shall require replacement of the entire set of extension cables.
- Manitowoc recommends for cable extended booms, that boom extension cables be replaced every seven (7) years.

Seizing Wire Rope

It is important to seize the ends of rotation resistant wire ropes to prevent the displacement and unraveling of the individual wires and strands at the ends. All preformed and non-preformed styles of wire rope should be seized prior to cutting. Seizings must be placed on both sides of the point where the wire rope is to be cut.

The two preferred methods for seizing wire ropes are:

Method 1

Using a length of soft annealed wire (Figure 1-7), place one end in the groove between two strands of the wire rope. Turn

the long end of the annealed wire at right angles to the wire and wrap it tightly over the portion in the groove.

The two ends of the annealed wire should be twisted together tightly. Cut off the excess wire and pound the twist flat against the wire rope.

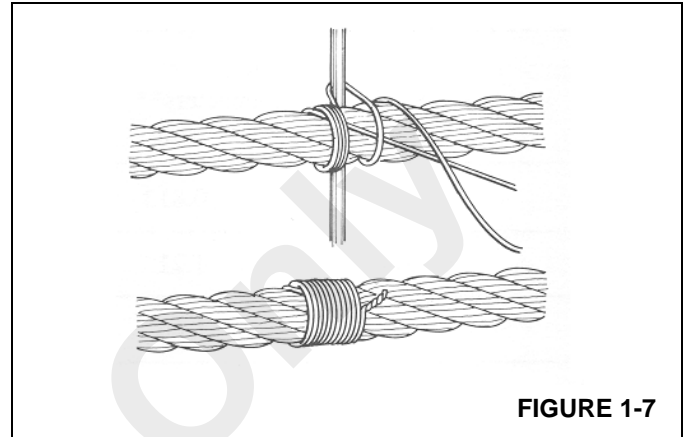

FIGURE 1-7

Method 2

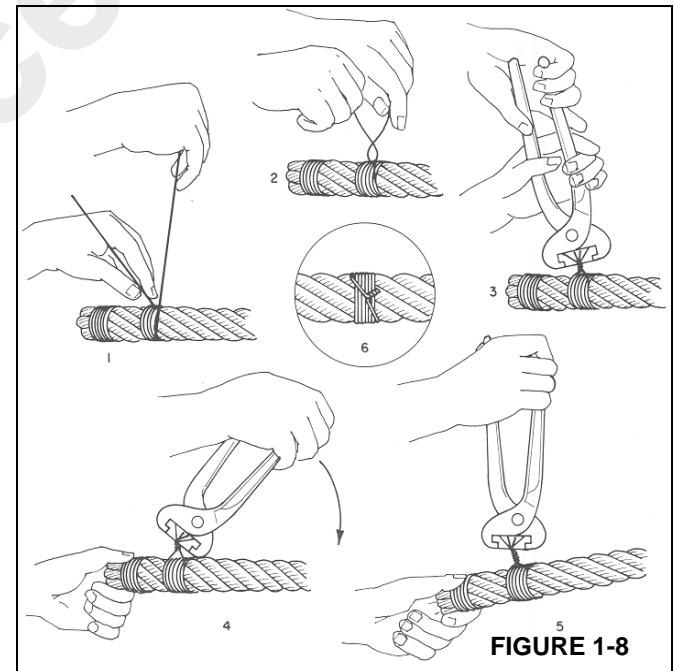

FIGURE 1-8

Wind a length of soft annealed wire (Figure 1-8) around the wire rope at least seven times. The two ends should be twisted together in the center of the seizing. Tighten the seizing by alternately prying and twisting. Cut off both ends of the wire and pound the twist flat against the rope.

NOTE: Non-preformed wire rope (1) (Figure 1-9) should have three seizings (3) located on each side of the cut (4) as compared to preformed wire rope (2).

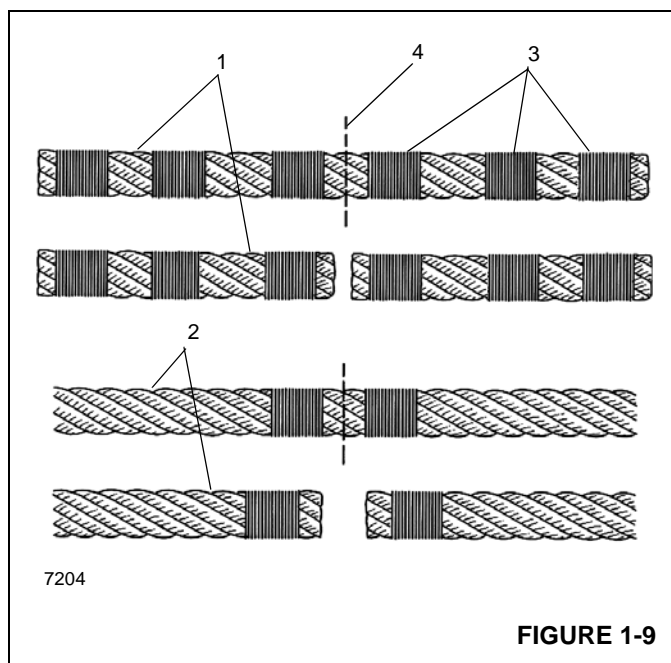

FIGURE 1-9

Installing 35x7 Class Wire Rope

CAUTION

Any cutting of this specific wire rope is not recommended. If 35x7 class wire rope must be cut for any reason, it is necessary to follow the attached instructions. Also, unlike other types of wire rope, the ends on this wire rope must be welded to retain the rotation resistant characteristics.

1. Unload properly and relieve any twists. Pull the rope off the shipping reel or unroll it from a shipping coil. (If done improperly, you may kink the rope, which will result in permanent damage to the rope.) Then lay the rope on the ground in direct line with the boom. This helps release any twist in the rope.
2. Attach rope's end to drum. Pull the rope over the point sheave and attach the end to the drum. Be sure not to remove the welded end.
3. Wind rope onto drum slowly and carefully. At this point, it isn't necessary to provide additional load other than the weight of the rope being pulled across the ground.
4. Spool first layer tightly. It is essential on smooth-faced drums that the first layer is spooled with wraps tight and close together since the first layer forms the foundation for succeeding layers. If need be, use a rubber, lead or brass mallet (but never a steel hammer) to tap the rope in place.
5. Spool multiple layers with sufficient tension. It's very important to apply a tensioning load to the ropes during the rope breaking-in process. (If not, the lower layers may be loose enough that the upper layers become

wedged into the lower layers under load, which can seriously damage the rope.) The tensioning load should range from 1 to 2% of the rope's minimum breaking force.

6. For ropes in multi-part systems: Reeve the traveling block and boom tip sheaves so the rope spacing is maximized and the traveling (hook) block hangs straight and level to help assure block stability.
7. Breaking in your new 35x7 class rope: After installation, you should properly break in your rope, which allows the rope's component parts to adjust themselves to your operating conditions.

With the boom fully raised and fully extended, attach a light load at the hook and raise it a few inches off the ground. Allow to stand for several minutes. Then cycle the load between the full "up" and "down" positions several times. Stand back and watch the drum winding and rope travel for any potential problems.

After making the lifts with a light load, increase the load and cycle it up and down a few times. This procedure will train the rope and help assure smooth operation during its useful life.

Ideally, you should run these loads with reeving that lets you place the loads on the block with all rope off the drum except the last three wraps. If this is not possible, alternate methods must be used to assure proper tensioning of the rope on the drum.

Procedures for Cutting and Preparing 35x7 Class Wire Rope

35x7 class wire rope is a special wire rope that must be handled differently than any other rope we manufacture. One characteristic that makes this rope special is that the outer strands are not preformed. It is because of this that the following procedures for cutting and preparing 35x7 class rope must be followed:

1. The welded ends prepared by the manufacturer are not to be removed.
2. Before cutting the rope, make three separate bands with seizing strand on each side of where the cut is to be made (total of six bands for each cut). Each band is to have a minimum length of one and one half times the rope diameter. The two bands closest to the cut should be located at a distance equal to one rope diameter away from the cut. The four remaining bands should be evenly spaced at a distance equal to three rope diameters.
 - a. If a welder is available, the cut should be made with an abrasive saw. Immediately after the cut, both ends of the rope are to be cap welded so that all inner and outer strands are welded together, preventing any movement between them.

NOTE: The outer strands must not be able to move with respect to the inner strands. The weld must not exceed the diameter of the rope.

- b.** If a welder is not available, the cut is to be made with an acetylene torch. The cut is to be made in such a way that both ends of the rope are completely fused so that all inner and outer strands are bonded together, preventing any movement between strands.

NOTE: The outer strands must not be allowed to move with respect to the inner strands. The fused end must not exceed the diameter of the rope.

- 3.** Once the cuts have been completed, the seizing bands are to be left in place for shipment of the rope.
- 4.** Attach a "Do not remove welded ends" tag on each reel flange.

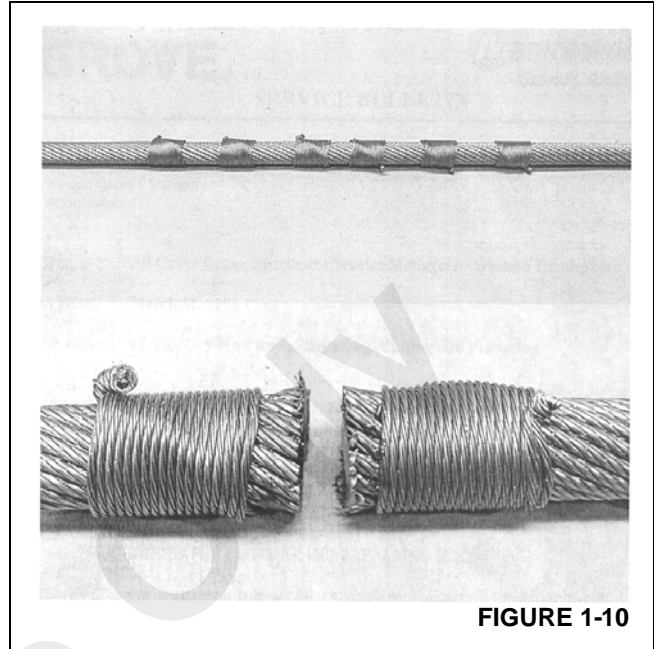

FIGURE 1-10

SECTION 2 HYDRAULIC SYSTEM

SECTION CONTENTS

Description	2-2	Description	2-35
Maintenance	2-5	Maintenance	2-35
Hydraulic Oil Recommendations	2-5	Tandem Brake Valve with Treadle Pedal	2-36
Draining and Flushing	2-5	Description	2-36
Removing Air from the Hydraulic System	2-6	Maintenance	2-36
Parts Replacement	2-6	Dual Accumulator Charge Valve	2-37
Directional Control Valves	2-6	Description	2-37
Supply Pressure and Return Circuit	2-8	Maintenance	2-37
Description	2-8	Hydraulic Accumulator Service Brake	2-39
Maintenance	2-9	Description	2-39
Oil Cooler	2-13	Maintenance	2-39
Description	2-13	Holding Valves	2-40
Hydraulic Pumps	2-14	Description	2-40
Description	2-14	Maintenance	2-40
Maintenance	2-14	Cross Axle Differential Lock Valve	2-41
Pressure Setting Procedures	2-17	Description	2-41
Procedure A - Checking/Setting the Main Control		Maintenance	2-41
Valve for Hoist(s), Boom Lift and Piston Pump. .	2-19	Outrigger Control Manifold	2-43
Procedure B - Setting The Outrigger/Rear Steer/Oil		Description	2-43
Cooler Motor Pressures	2-19	Maintenance	2-43
Procedure C - Checking/Setting the Swing Directional		Pilot Operated Check Valve	2-44
Control Valve Work Port Relief Valves	2-20	Description	2-44
Procedure D - Checking/Setting the Service Brake		Maintenance	2-44
Dual Accumulator Charge Valve Charging Limits	2-20	Integrated Outrigger/Rear Steer Manifold	2-45
Procedure E - Checking/Pre-Charging the Service		Description	2-45
Brake Accumulators	2-20	Maintenance	2-45
Procedure F - Checking/Setting the Front Steer		Check Valves	2-48
Pressure	2-21	Description	2-48
Procedure G - Checking/Setting the Pilot Supply		Maintenance	2-48
Pressure	2-21	Range Shift/Parking Brake Valve	2-49
Procedure H - Checking/Setting the Swing Brake		Description	2-49
Release Pressure	2-21	Maintenance	2-49
Procedure J - Setting Threshold on Electronic		Axle Oscillation Lockout Valve	
Controllers	2-21	(Standard Units)	2-50
Valves	2-27	Description	2-50
General	2-27	Maintenance	2-50
Directional Control Valves	2-30	Axle Oscillation Lockout Valve	
Description	2-30	(Optional CE Units)	2-52
Maintenance	2-30	Description	2-52
Accessory With Swing Directional Control Manifold		Maintenance	2-52
2-33		Cylinders	2-54
Description	2-33	General	2-54
Maintenance	2-33	Maintenance	2-54
Steering Control Valve	2-35		

Surface Protection for Cylinder Rods	2-54	Steer Cylinder	2-68
Lift Cylinder	2-57	Description	2-68
Description	2-57	Maintenance	2-68
Maintenance	2-57	Outrigger Extension Cylinder	2-71
Dual Rod Telescope Cylinder	2-60	Description	2-71
Description	2-60	Maintenance	2-71
Maintenance	2-60	Outrigger jack Cylinder	2-73
Axle Oscillation Lockout Cylinder	2-64	Description	2-73
Description	2-64	Maintenance	2-73
Maintenance	2-64		

DESCRIPTION

This section describes the hydraulic system, the components which make up the hydraulic system, and the components dependent upon the hydraulic system for their operation. This includes descriptions of the supply pressure and return hydraulic circuit, hydraulic pumps, all hydraulic valves, and all hydraulic cylinders. Detailed descriptions and

operation of individual hydraulic circuits are discussed within their individual sections as applicable. A complete hydraulic system schematic showing all options is at the back of this manual and a figure titled A.N.S.I. Graphical Symbols provides hydraulic symbol information for this section (Figure 2-1) and (Figure 2-2).

LINES AND LINE FUNCTIONS			
LINE, WORKING		CYLINDER-SINGLE ACTING	
LINE, PILOT		CYLINDER-DOUBLE ACTING DIFFERENTIAL	
LINE, DRAIN		NON-DIFFERENTIAL	
CONNECTOR		VALVES	
LINE, FLEXIBLE		CHECK	
LINE, JOINING		ON-OFF (MANUAL SHUT-OFF)	
LINES, PASSING		PRESSURE RELIEF	
DIRECTION OF FLOW		PRESSURE REDUCING	
LINE TO RESERVOIR ABOVE FLUID LEVEL		FLOW CONTROL ADJUSTABLE NON-COMPENSATED	
BELOW FLUID LEVEL		FLOW CONTROL ADJUSTABLE (TEMPERATURE AND PRESSURE COMPENSATED)	
LINE TO VENTED MANIFOLD		TWO POSITION TWO CONNECTION	
PLUG OR PLUGGED CONNECTION		TWO POSITION THREE CONNECTION	
RESTRICTION, FIXED		TWO POSITION FOUR CONNECTION	
RESTRICTION, VARIABLE		THREE POSITION FOUR CONNECTION	
PUMPS		TWO POSITION IN TRANSITION	
SINGLE, FIXED DISPLACEMENT		VALVES CAPABLE OF INFINITE POSITIONING (HORIZONTAL BARS INDICATE INFINITE POSITIONING ABILITY)	
SINGLE, VARIABLE DISPLACEMENT			
ACTUATORS			
MOTOR, FIXED DISPLACEMENT REVERSIBLE			
MOTOR, FIXED DISPLACEMENT NON-REVERSIBLE			
MOTOR, VARIABLE DISPLACEMENT, REVERSIBLE			

1951-1

FIGURE 2-1

METHOD OF OPERATION		MISCELLANEOUS	
SPRING		ROTATING SHAFT	
MANUAL		ENCLOSURE	
PUSH BUTTON		RESERVOIR VENTED	
PUSH - PULL LEVER		PRESSURIZED	
PEDAL OR TREADLE		PRESSURE GAUGE	
MECHANICAL		ELECTRIC MOTOR	
DETENT		ACCUMULATOR, SPRING LOADED	
PRESSURE COMPENSATED		ACCUMULATOR, GAS CHARGED	
SOLENOID, SINGLE WINDING		HEATER	
REVERSING MOTOR		COOLER	
PILOT PRESSURE REMOTE SUPPLY		TEMPERATURE CONTROLLER	
INTERNAL SUPPLY		FILTER, STRAINER	

FIGURE 2-2

MAINTENANCE

Hydraulic Oil Recommendations.

For the hydraulic oil specifications, refer to Section 9 - LUBRICATION.

Draining and Flushing

If a component has been changed because of a failure that might allow metal or abrasive particles to enter the system, all systems must be thoroughly checked, drained, and flushed.

1. Remove the reservoir drain plug. Allow about three minutes after hydraulic oil stops flowing from the drain port for the side walls to drain.
2. Clean and install the reservoir plug and fill the reservoir with a 50/50 mixture of fuel oil and clean hydraulic oil.
3. Cycle the crane through all functions several times. Then return the crane to its stowed position and turn the front and rear wheels to the extreme left. Shut down the engine.
4. Remove the reservoir drain plug and drain the reservoir. Clean and install the drain plug and fill the reservoir with clean hydraulic oil.

CAUTION

Hydraulic oil supply lines must be connected to the cylinders when flushing the system.

NOTE: Draining the various components will be aided by connecting a drain line in place of the disconnected return line.

5. Disconnect the return line from the lift cylinder and raise the boom to maximum elevation.
6. Connect the cylinder return line and lower the boom to its stowed position. Replenish the reservoir hydraulic oil level as required.
7. Disconnect the return line from an outrigger extension cylinder and fully extend the outrigger.
8. Connect the outrigger return line and retract the outrigger. Replenish the reservoir hydraulic oil level as necessary.
9. Repeat Steps 7 and 8 for the remaining outriggers.

CAUTION

When draining the outrigger cylinders, always operate either both front or both rear cylinders together to prevent twisting the crane.

10. Disconnect the return lines from a pair of outrigger jack cylinders and activate the cylinders to their maximum down positions.
11. Connect the return lines and raise the outrigger jack cylinders to the stowed position. Replenish the reservoir hydraulic oil level as necessary.
12. Repeat Steps 10 and 11 for the remaining two outrigger cylinders.
13. Disconnect the return line from the telescope cylinder and fully extend the boom.
14. Connect the return line and retract the boom. Replenish the reservoir hydraulic oil level as necessary.
15. Disconnect the return lines from both front steer cylinders and turn the front wheels to the extreme right.
16. Connect the return lines and turn the front wheels to the extreme left and then back to center. Replenish the reservoir hydraulic oil level as necessary.
17. Repeat Steps 15 and 16 for the rear steering cylinders.
18. Raise the crane on outriggers.
19. Disconnect the line from port A of the axle lockout valve.
20. Using a jack under the rear wheel on one side of the crane, jack up the wheel to maximum travel.
21. Connect the line to port A of the axle lockout valve and disconnect the line from Port B.
22. Repeat step 19 using the other rear wheel.
23. Connect the line to port B of the axle lockout valve. Energize the axle lockout valve. Replenish the reservoir hydraulic oil level as necessary.
24. Disconnect the return line from the main hoist motor and fully hoist up the hoist.
25. Connect the return line to the main hoist motor and fully hoist down the hoist, then hoist up again. Replenish the reservoir hydraulic oil level as necessary.
26. Repeat Steps 24 and 25 for the auxiliary hoist as necessary.
27. Disconnect one of the lines from the swing motor and drive the motor in the direction it will go.
28. Connect the line to the swing motor, then drive the swing motor in the opposite direction until the boom is centered and forward. Replenish the reservoir hydraulic oil level as necessary.

CAUTION

When hydraulic oils are changed or added, ensure that hydraulic oils of different manufacturers are of the same specifications. Discoloration may occur.

When hydraulic oils are changed, recheck the reservoir hydraulic oil level after brief system operation and add hydraulic oil as required. Ensure the crane is level and in the travel mode of operation when the hydraulic system is being filled. The system must be filled with all cylinders retracted. Fill the reservoir to the full mark on the reservoir sight gauge. After the reservoir is filled, operate all circuits and recheck the reservoir sight gauge. Add hydraulic oil as required.

Removing Air from the Hydraulic System

Air entering the hydraulic oil will normally be removed automatically by passage of the hydraulic oil over the baffles in the hydraulic reservoir. If a component has been replaced, the reservoir level is too low, or a leak develops in the suction lines to the pumps, air can enter the system. If air becomes entrapped in the hydraulic oil, it may be detectable in pumps and motor operated components such as the swing mechanism and hoist(s), because it can cause these units to become noisy during operation. If noisy operation occurs, first check the level of the hydraulic reservoir and replenish as necessary. Then inspect for leaks in the suction lines leading to the pumps.

Minute leaks may be hard to locate. If a leak is not readily detectable, use the following way to check for it:

Seal all normal openings in the hydraulic system and the reservoir. Using a positive means to control the pressure (like a regulator), pressurize the hydraulic system to 13.8 to 27.6 kPa (0.14 to 0.28 bar) (2 to 4 psi) and inspect all joints and fittings for evidence of leaks. A soap solution applied to the fittings and joints may also prove helpful in detecting minute leaks while the system is pressurized. Remove the pressure, repair any leaks found, and reopen any openings (such as a vent) closed for inspection. Refill the reservoir after completing any repairs or service. Operate all hydraulic circuits several times in both directions.

This action should return any entrapped air to the reservoir where it can be removed from the hydraulic oil by the baffles.

DANGER Tipping Hazard

To avoid death or serious injury, locate the machine on a firm supporting surface and position the boom over the front on outriggers when extending the boom at low angles.

To remove entrapped air from telescope cylinders, lower the boom to below horizontal and fully telescope the boom in and out several times.

If the air is not readily removed, lower the boom to below horizontal, extend the telescope cylinders as far as practicable, and allow the boom to remain in this position overnight. This should allow entrapped air to find its way to the holding valve so that telescoping the boom IN the next morning should force the air back to the reservoir. Ensure the boom is first telescoped IN (not OUT) in the morning. Telescoping OUT may cause air to be forced back into a cylinder.

DANGER

Pressurized fluid can cause serious injury or death. Extreme care must be used when removing any plugs or restrictions from a hydraulic system suspected to have entrapped air that may be pressurized.

Entrapped air may be removed from cylinders having wet rods by cycling. On certain cylinders, a plugged port is provided on the rod end to bleed off entrapped air.

DANGER

Pressurized fluid can cause serious injury or death. Do not attempt to loosen fittings in pressurized lines or while the hydraulic pumps are in operation.

In the event that air entrapment should persist, bleeding of air by loosening various clamp and screw type fittings may become necessary.

If the above procedures fail to eliminate air entrapment, contact your authorized Grove Distributor.

Parts Replacement

Parts found damaged or out of tolerance when maintenance is being performed should be replaced. Refer to the Manitowoc Crane Care Parts Catalog for proper replacement parts.

Directional Control Valves

The control valves that control the crane functions are installed on the right side on the outside of the superstructure side plate, and between the left and right superstructure side plates under the main hoist.

Inspection

Inspect the control valves for visible damage, binding spools, and evidence of leakage. If excessive internal leakage is suspected during operation with a spool in its center position, it is possible that the area between the spool and working section bore of the valve body is worn beyond serviceable

limits. If this condition exists, the spool and body must be replaced as an assembly.

Valve Leakage

Dripping hydraulic oil indicates some type of external leakage. The machine should be removed from service for immediate repairs. External leaks sometimes develop at fittings and seals. Seals may be damaged by temperatures that are too high, or by dirt or paint accumulation on the spool. Damaged or torn seals must be replaced.

A component functioning at reduced efficiency may indicate that the control valve for that component is leaking internally. If preliminary check-out reveals that adequate volume is being supplied to the affected valve bank, relief valves are properly adjusted, and the component is not at fault, check the valve for scored or worn parts. Scoring is a sign of the number one problem in hydraulics - contamination (external contamination by dust or internal contamination by debris from deteriorating components or oxidized hydraulic oil). Scored or severely worn valve components must be replaced.

Check valves in the control valves are designed to permit a flow of hydraulic oil in one direction only. If a piece of dirt or rust has worked its way into the check valve and lodges

between the poppet and seat, it will keep the valve open and allow a return flow of hydraulic oil. The remedy is to clean the valve, but it is also a good idea to follow through and ensure the hydraulic system filter is still serviceable.

Binding Spools

Some of the most common causes for stiff spool movement or jammed spool action are system overheating, excessive pressure, contaminated or deteriorated hydraulic oil, or warped mountings. When scorched, deteriorated hydraulic oil or contamination is the cause, flushing the system and replenishing with clean hydraulic oil may solve the problem. If the spool bores are badly scored or galled, the valve must be removed for servicing.

Warping occurs when mounting plates are not level or they become distorted from machine damage. As mentioned previously, the valve can be shimmed level.

Also, check the valve for rust. Rust or dirt collecting on the valves can prevent free movement of the spool, and keep it from the true center position. Excessive system pressure can create both internal and external leaks in valves that are otherwise sound. Only qualified technicians using the correct equipment should make pressure adjustments when pressure adjustments are needed.

SUPPLY PRESSURE AND RETURN CIRCUIT

Description

The supply pressure and return circuit is made up of several circuits which route hydraulic oil from the hydraulic pumps to the directional control valves for the individual operating circuits. The supply pressure and return circuit consists of the reservoir and integral filter, two hydraulic pumps, a hydraulic oil cooler, and a 12-port hydraulic swivel. Refer to HYDRAULIC PUMPS in this section for descriptions and maintenance instructions for each hydraulic pump. Refer to Section 6 - SWING for description and maintenance instructions for the 12-port hydraulic swivel.

The supply pressure and return circuit uses Ports 5 and 6 for pump supply and the dual Port 4 for return. Each operating circuit's description and components begin with the circuit's directional control valve.

Hydraulic Reservoir and Filter

The reservoir (Figure 2-3), attached to the right side of the carrier frame, has a capacity of 442.3 l (116.8 gal) total, 395.9 l (104.6 gal) to the full mark. The all-steel reservoir has an internally mounted full-flow filter and integral baffles that help cool the hydraulic oil and prevent hydraulic oil foaming.

Hydraulic oil flows through three tubes at the rear of the reservoir to the three hydraulic pumps. Almost all of the return flow goes through the filter at the top of the reservoir. The return line that goes directly into the reservoir (instead of through the filter) is from the No. 10 port (drain) of the 12-port swivel.

A magnetized drain plug in the bottom of the reservoir collects metal particles from the hydraulic oil if it becomes contaminated.

A sight gauge is located on the front of the reservoir to indicate hydraulic oil level.

1. A breather/fill cap located on the top of the reservoir allows air to enter or exhaust the reservoir. It consists of a breather, fill neck, gaskets and strainer. It is important that the breather be kept clean to prevent damage to the reservoir. The breather/fill cap also provides for filling the reservoir.

A large access cover on top of the reservoir provides for cleaning. The access cover can also be used to fill the reservoir after it has been completely drained.

An oil temperature gauge is located on the lower front of the reservoir to indicate oil temperature.

The hydraulic oil filter (Figure 2-4) is located in the top of the reservoir. The filter housing contains a replaceable filter element. Returning hydraulic oil flows through the filter head, through the filter element and into the reservoir.

An element condition indicator on the filter head indicates when to change the filter element. When back pressure caused by a dirty filter element exceeds 172.3 kPa/1.72 bar (25 psid), the filter head's bypass feature functions to allow the hydraulic oil to bypass the filter element and flow into the reservoir through the bypass outlet instead. A bypass filter screen prevents gross contamination from passing through the filter even during bypass. Refer to Return Hydraulic Filter for filter changing instructions.

Pump Distribution

Pump No. 1 is mounted off drive pads of the torque converter. Pump No. 2 is mounted on the left front side of the engine.

Pump No. 1

Pump No. 1 is a variable displacement axial piston pump with a maximum displacement of 112 cm³/rev (6.83 in³/rev). The pump differential or standby pressure is 2413 kPa/24 bar (350 psi). Pump No. 1 supplies oil to the integrated outrigger/rear steer valve, boom lift, telescope, hoist, brakes and pilot functions.

Pump No. 2

Pump No. 2 is a single positive displacement gear pump with a displacement of 39 cm³/rev (2.40 in³/rev) delivering a theoretic flow of 84 lpm (21.9 gpm). Pump No. 2 supplies oil to the front steer and swing circuits.

Pump No. 3

Pump No. 3 is a single positive displacement gear pump with a displacement of 19 cm³/rev (1.16 in³/rev) delivering a theoretic flow of 57.2 lpm (10.6 gpm). Pump No. 3 supplies oil to the transmission oil cooler fan motor.

Maintenance

Troubleshooting

Symptom	Probable Cause	Solution
1. No hydraulic oil flows in systems.	a. Low hydraulic oil level.	a. Fill reservoir.
	b. Reservoir-to-pump suction lines broken or restricted. Air entering at suction lines. Pump not priming.	b. Clean, repair, or replace lines as necessary. Check lines for security, absence of cracks, and proper attachment. Tighten, repair, or replace parts as necessary.
	c. Pump shaft sheared or disengaged.	c. If drive shaft is damaged or sheared, remove and repair or replace as necessary.
	d. Internal contamination.	d. Drain, flush with recommended oil mixture, then drain and refill system with recommended hydraulic oil.
2. Slow response.	a. Low hydraulic oil level.	a. Fill reservoir.
	b. Hydraulic oil temperature too high (watery thin oil) or too low (thick sluggish oil).	b. If too low, warm up system. As needed, troubleshoot cooler circuit. If too high, troubleshoot cooler circuit. Likely suspects are in-line check valve and related hydraulic circuits.
	c. Faulty pump section(s).	c. Repair or replace pump section(s) or entire pump.
3. Pump noise accompanied by hydraulic oil foaming in reservoir.	a. Low hydraulic oil level.	a. Fill reservoir.
	b. Excessive engine speed.	b. Regulate engine speed.
	c. Air entering at suction lines.	c. Check all lines for security and proper repair. Tighten, repair, or replace as needed.
4. Excessive pressure buildup.	a. System relief valve set too high.	a. Using adequate pressure gauge, adjust system relief valve as necessary.
	b. Restricted pump-to-control valve supply line.	b. Clean, repair, or replace line as necessary.
5. Specific hydraulic system (lift, hoist, telescope, swing) not working.	a. Leak in system.	a. Repair leak.
	b. Faulty electric controls/signals.	b. Adjust or replace controls signals.
	c. Faulty directional control valve.	c. Replace valve.
	d. Poorly adjusted control in circuit.	d. Troubleshoot circuit with schematic. Adjust hydraulic component per schematic.
	e. Faulty hydraulic cylinder, motor, or valve.	e. Replace faulty component.

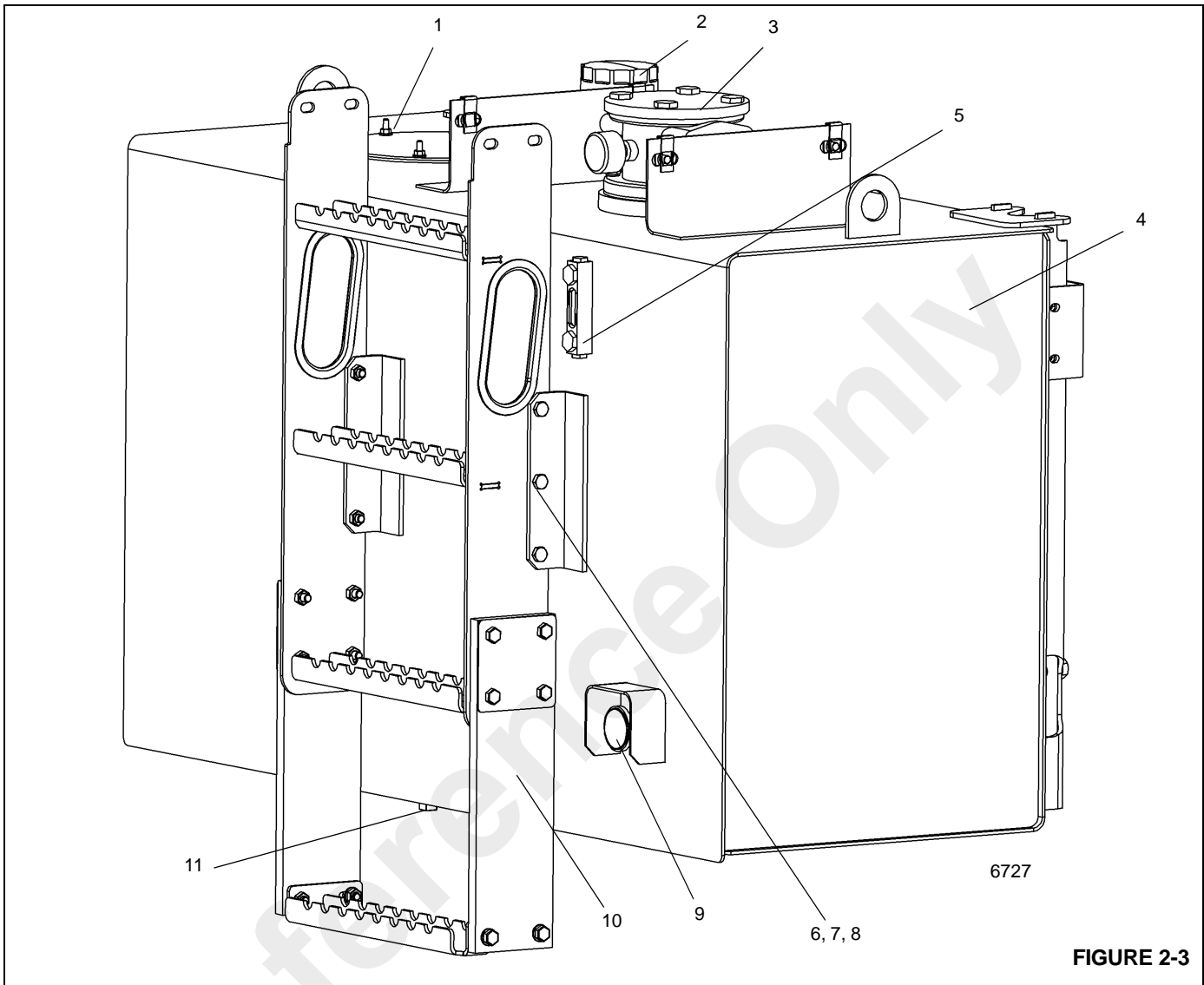

FIGURE 2-3

Item	Description
1	Access Cover
2	Breather/Fill Cap
3	Return Line Filter
4	Reservoir
5	Sight Gauge
6	Capscrew

Item	Description
7	Hex Locknut
8	Flatwasher
9	Thermometer (Temperature Gauge)
10	Ladder
11	Magnetic Plug

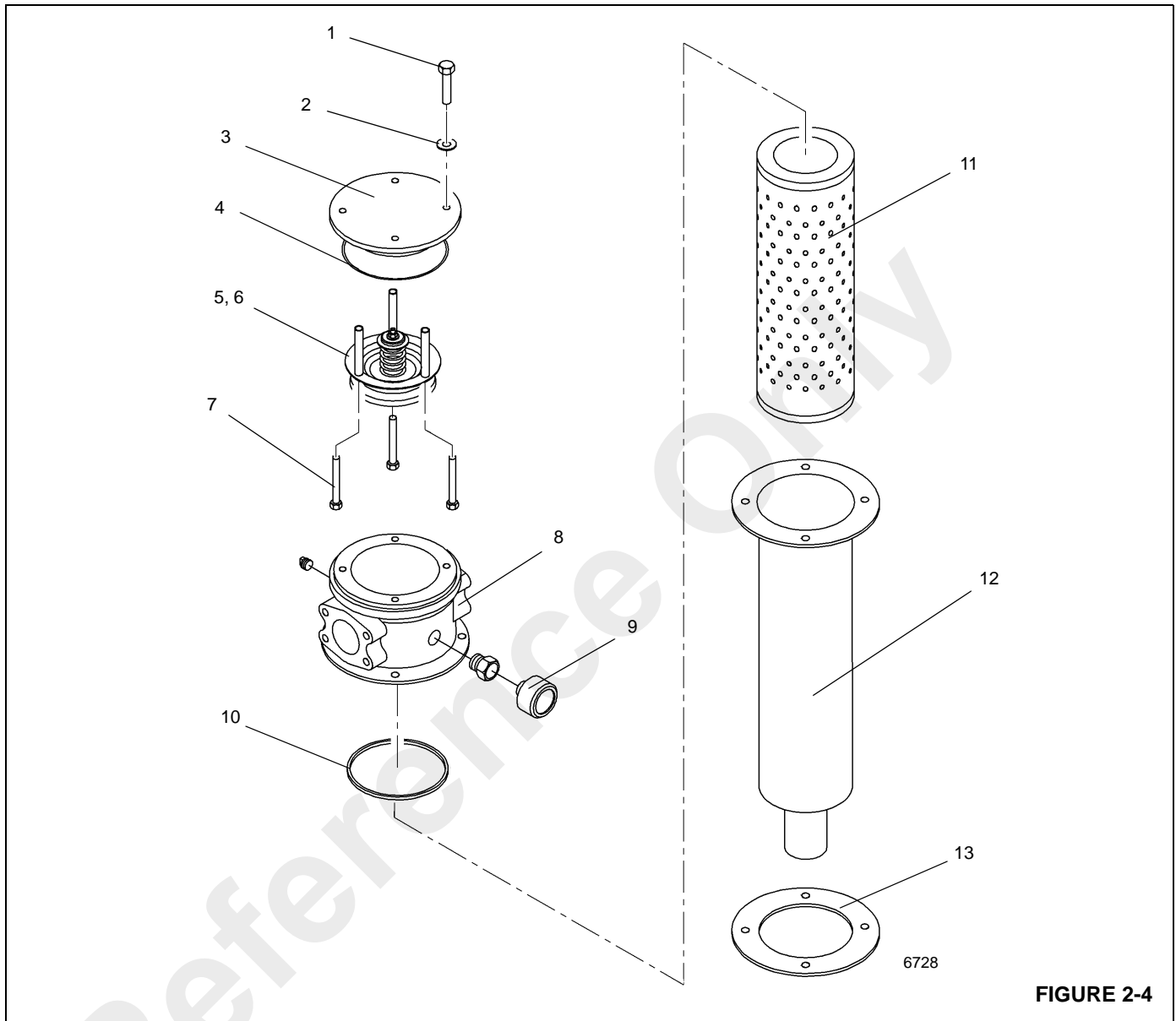

FIGURE 2-4

Item	Description
1	Capscrew
2	Washer
3	Cap
4	O-ring
5	Bypass Valve
6	Spacer
7	Capscrew

Item	Description
8	Filter Head
9	Gauge
10	O-ring
11	Element
12	Bowl
13	Gasket

Return Hydraulic Filter Assembly

Element Removal



DANGER

Ensure that all hydraulic systems are shut down and the pressure is relieved.

1. Shut down all hydraulic systems.
2. Wipe any dirt from the filter head and cap assembly.

NOTE: The bypass valve assembly is installed to the cap and is removed with the cap.

3. Remove the four bolts securing the cap assembly to the filter head. Remove the cap and bypass valve assembly.
4. Remove the filter element from the filter bowl (housing).
5. Ensure the new filter element is correct by comparing their part numbers with the part numbers of the used element.
6. Discard the element.

Element Installation

1. Place a new element into the filter bowl (housing).
2. Install new O-ring in the cap assembly.
3. If by-pass valve was removed from cap, install by-pass capscrews to cap.
4. Install cap assembly on filter head and secure with the four bolts. Torque bolts 14.9 ± 2.7 Nm (11.00 ± 2.00 lb-ft) until the gasket starts to bulge slightly. Do not over torque. Torque bolt in a criss-cross pattern.
5. Activate the hydraulic system and check for leaks. make repairs as necessary.

Hydraulic Reservoir Removal

Remove the capscrews, flatwashers, lockwashers and hex nuts securing the reservoir to the frame. Using a suitable lifting device, remove the reservoir.

Hydraulic Reservoir Installation

Using a suitable lifting device, install the reservoir to the frame and secure with the capscrews, flatwashers, lockwashers and hex nuts. Torque the capscrews see *Fasteners and Torque Values*, page 1-11.

OIL COOLER

Description

An air cooled hydraulic oil cooler (Figure 2-5) is installed on the rear of the superstructure behind the hoists.

When the oil temperature reaches 48.8°C (120°F), the normally closed temperature switch opens to turn on the oil cooler electric motor which drives the oil cooler fan.

The oil cooler fan pulls cool air through the cooling fins on the cooler. Normally, most hydraulic oil from components is routed through the oil cooler by way of a return line and on to

the filter in the reservoir. When several hydraulic functions are being used at one time (i.e., hoisting, lifting, and telescoping), more oil has to flow through this return line, causing a pressure buildup. When this pressure reaches 206.8 kPa/2.0 bar (30 psi), the normally closed check valve in the return line (in parallel with the return line through the hydraulic oil cooler) will open, letting some hydraulic oil bypass the hydraulic oil cooler and flow directly into the reservoir filter.

When fewer functions are being used, the pressure in the system will decrease below 206.8 kPa/2.0 bar (30 psi) and the check valve will close again.

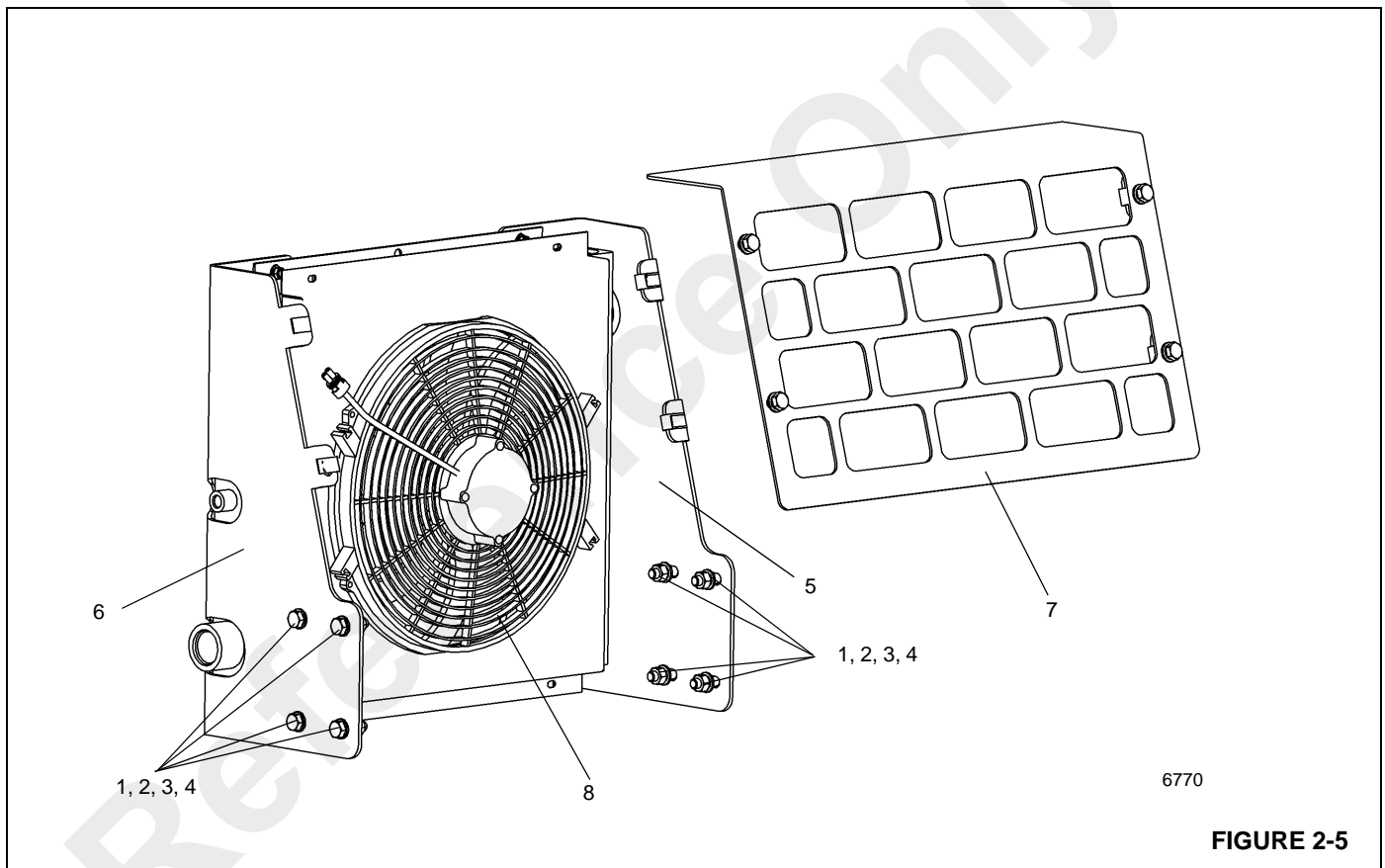

FIGURE 2-5

Item	Description
1	Flatwasher
2	Lockwasher
3	Capscrew
4	Hex Nut

Item	Description
5	Mounting Bracket
6	Mounting Bracket
7	Shield Plate
8	Oil Cooler

HYDRAULIC PUMPS

Description

Pump No. 1 is mounted off drive pads of the torque converter. Pump No. 2 is mounted on the left front side of the engine (Figure 2-6).

Pump No. 1

Pump No. 1 is a variable displacement axial piston pump with a maximum displacement of 112 cm³/rev. (6.83 in³/rev). The pump differential or standby pressure is 2413 kPa/24 bar (350 psi). Pump No. 1 supplies oil to the integrated outrigger/rear steer valve, boom lift, telescope, hoist, brakes and pilot functions.

Pump No. 2

Pump No. 2 is a single positive displacement gear pump with a displacement of 39 cm³/rev. (2.40 in³/rev) delivering a theoretic flow of 84 lpm (21.9 gpm). Pump No. 2 supplies oil to the front steer and swing circuits.

Pump No. 3

Pump No. 3 is a single positive displacement gear pump with a displacement of 19 cm³/rev. (1.16 in³/rev) delivering a theoretic flow of 57.2 lpm (10.6 gpm). Pump No. 3 supplies oil to the transmission oil cooler fan motor.

Maintenance

No. 1 Pump Removal

CAUTION

Absolute cleanliness is essential when working on the hydraulic pumps. Always work in a clean area. The presence of dirt and foreign materials in the system can result in serious damage or inadequate operation.

1. For ease of removal, gain access to the pump by removing the engine hood. The pump is bolted to the engine's torque converter.
2. Tag and disconnect the supply line from the pump. Cap or plug the line and port.
3. Tag and disconnect the pump distribution lines from the pump. Cap or plug the lines and ports.

CAUTION

When removing the pump, keep the pump as level as possible to avoid damaging the input spline.

NOTE: Charge pump and two studs must be removed for wrench access to piston pump mounting bolts.

4. Remove the capscrews and washers attaching the pump to the drive pad on the torque converter. Remove the pump.
5. Clean the gasket material from the drive pad on the torque converter.
6. Cover the drive pad's opening to prevent dirt from entering.

No. 1 Pump Installation

1. Install new gasket material to the pump mounting flange.
2. Install pump on torque converter drive pad with capscrews and washers. Make sure the splines mesh properly. Torque capscrews 292 to 317.2 Nm (216 to 234 foot-pounds).
3. Replace the charge pump and studs.
4. Connect the distribution and supply lines as tagged during removal.

No. 2 Pump Removal

CAUTION

Absolute cleanliness is essential when working on the hydraulic pumps. Always work in a clean area. The presence of dirt and foreign materials in the system can result in serious damage or inadequate operation.

1. For ease of removal, gain access to the pump by removing the engine hood.
2. Tag and disconnect the supply line from the pump. Cap or plug the line and port.
3. Tag and disconnect the pump distribution line(s) from the pump. Cap or plug the line(s) and port.

CAUTION

When removing the pump, keep the pump as level as possible to avoid damaging the input spline.

4. Remove the capscrews and washers attaching the No. 2 pump to the drive pad on the torque converter. Remove the pump.
5. Remove the gasket material from the drive pad on the torque converter.
6. Cover the drive pad's opening to prevent dirt from entering.

No. 2 Pump Installation

1. Install new gasket material to the pump mounting flange.
2. Install pump on to left front of engine with capscrews and washers. Make sure gear teeth mesh properly. Torque capscrews to 85 to 93 Nm (63 to 69 lb-ft).
3. Connect the distribution and supply lines as tagged during removal.

CAUTION

Do not feed hot hydraulic oil into a cold pump. This may cause the pump to seize.

No. 3 Pump Removal

CAUTION

Absolute cleanliness is essential when working on the hydraulic pumps. Always work in a clean area. The presence of dirt and foreign materials in the system can result in serious damage or inadequate operation.

1. For ease of removal, gain access to the pump by removing the engine hood.
2. Tag and disconnect the supply line from the pump. Cap or plug the line and port.
3. Tag and disconnect the pump distribution line(s) from the pump. Cap or plug the line(s) and port.

CAUTION

When removing the pump, keep the pump as level as possible to avoid damaging the input spline.

4. Remove the capscrews and washers attaching the No. 3 pump to the No. 1 pump. Remove the pump.
5. Remove the gasket material from the drive pad on the No. 1 pump.
6. Cover the drive pad's opening to prevent dirt from entering.

No. 3 Pump Installation

1. Clean and prime the mounting surfaces with Loctite 7649 primer.
2. Apply Loctite 518 sealant to the pump mounting flange.
3. Install pump on to pump No. 1 with capscrews and washers. Make sure gear teeth mesh properly. Torque capscrews to spec listed in *Fasteners and Torque Values*, page 1-11.

4. Connect the distribution and supply lines as tagged during removal.

CAUTION

Do not feed hot hydraulic oil into a cold pump. This may cause the pump to seize.

Testing After Rebuild or Replacement

1. Operate the pump for at least two minutes at zero pressure and moderate speed (not over 1500 rpm).

CAUTION

If the pump becomes hot to the touch, it is binding and may seize. Stop engine, disassemble pump, and repair it so it will not bind.

2. Touch pump to verify it has not become hot from binding. Listen for abnormal noises indicating low hydraulic oil level or internal pump problems. If the pump appears to be operating satisfactorily, increase the rpm by steps, until reaching governed rpm. Operate pump about five minutes while checking for proper operation and leakage. Fix leaks; make repairs as needed.
3. Cycle the components the pump powers to verify the pump drives them all properly.

Hydraulic Gear Pump Start-up Procedure

1. Ensure the reservoir is filled with the proper hydraulic fluid to the high level mark on the reservoir sight gauge.
2. Ensure no air is entering the pump inlet, and that the pump suction or inlet fluid is not bleeding back to the reservoir when the engine is stopped, by making sure all suction or inlet lines are air tight.

NOTE: The following step can be done before the pump is installed by removing the plastic cap from "T1" port, and checking to ensure "T2" port on the opposite side of the pump is plugged. Fill housing full of hydraulic oil through "T1" port. Re-install the plastic cap and then install the pump.

3. Remove adapter and hose from "T1" port, and check to ensure "T2" port on the opposite side of the pump is plugged. Fill housing full of hydraulic oil through "T1" port. Re-install the adapter and hose into the "T1" port.
4. Start the engine.
 - a. Idle engine for two to three minutes with no functions actuated. Check for leaks and repair if required. Lay hand on pump to check for excessive heat build-up. If the pump section is too hot to touch, stop immediately. If the pump makes excessive noise, air is probably entering the pump keeping it

from priming. If this occurs, stop engine, and inspect all connections of the suction hose/tube for a loose connection, or a missing or damaged O-ring. Re-start the engine and run until the pump takes prime for a maximum of 30 seconds. If the pump does not prime in 30 seconds, stop the engine and repeat until the pump primes.

- b. Increase the RPM to 1500-1800 for 1 to 2 minutes with no functions actuated and make checks again as outlined in step a. Incrementally increase throttle to full RPM and then cycle the functions that the pump supplies to verify proper speed. Verify pump flow.
5. Check pressure settings. Refer to PRESSURE SETTING PROCEDURES in this section.

Piston Pump Start-up Procedure

1. Ensure the reservoir is filled with the proper hydraulic fluid to the high level mark on the reservoir sight gauge.
2. Ensure no air is entering the pump inlet, and that the pump suction or inlet fluid is not bleeding back to the reservoir when the engine is stopped, by making sure all suction or inlet lines are air tight.
3. Remove the case drain hose and adapter from port DR on the pump (Figure 2-7), and fill housing with the same hydraulic oil that was used to fill the hydraulic reservoir to the bottom of the O-ring case drain port. Install the case drain adapter and hose.
4. Start the engine.
 - a. Idle engine for two to three minutes with no functions actuated. Check for leaks and repair if required. Lay hand on pump to check for excessive heat build-up. If the pump section is too hot to keep a hand on, stop immediately. If the pump makes excessive noise, air is probably entering the pump keeping it from priming. If this occurs, stop engine, and inspect all connections of the suction hose/tube for a loose connection, or a missing or damaged O-ring. Re-start the engine and run until the pump takes prime for a maximum of 30 seconds. If the pump does not prime in 30 seconds, stop the engine and repeat until the pump primes.
 - b. Increase the RPM to 1500-1800 for 1 to 2 minutes with no functions actuated and make checks again as outlined in step a. Incrementally increase throttle to full RPM and then cycle the functions that the pump supplies to verify proper speed. Verify pump flow.
5. Check pressure settings. Refer to Pressure Setting Procedures (pg 2- 17) in this section.

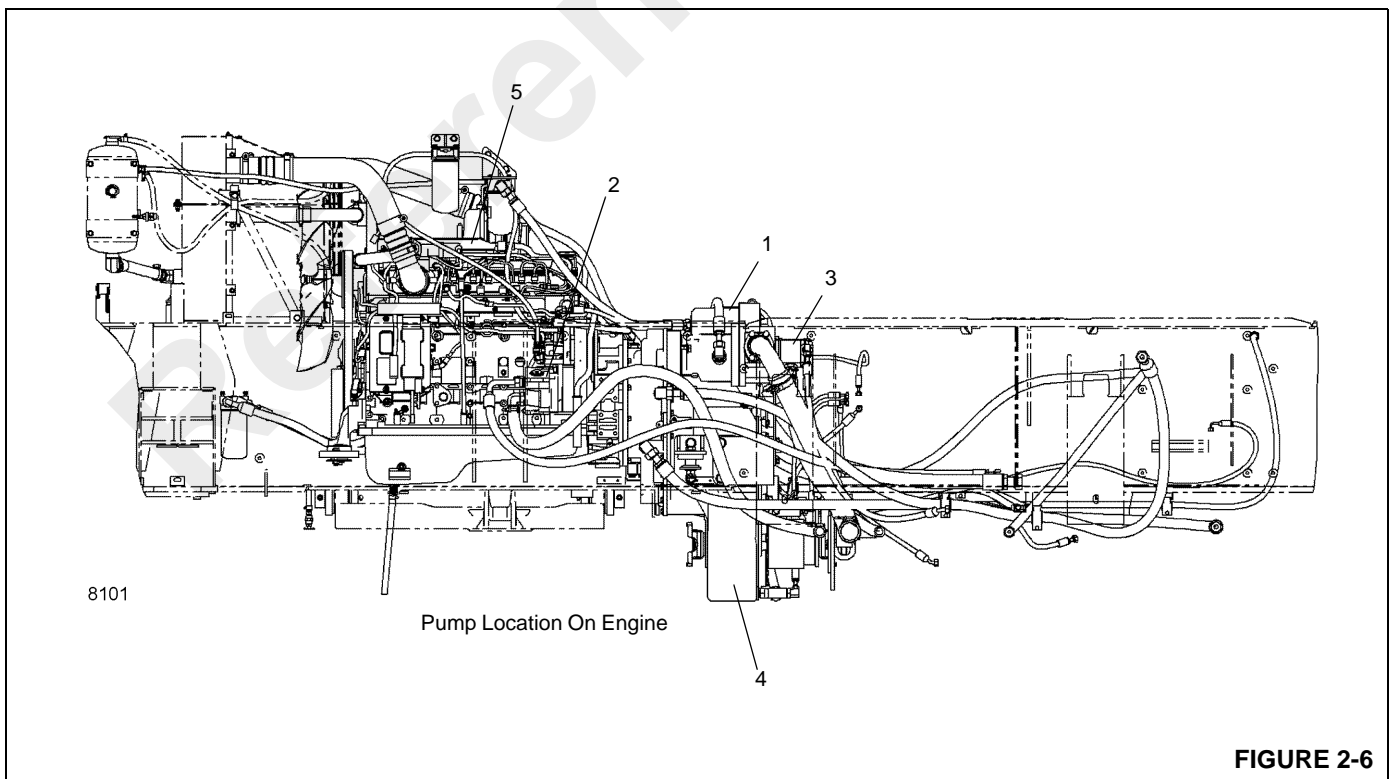

Item	Description
1	Pump No. 1 - Piston Pump
2	Pump No. 2 - Gear Pump
3	Pump No. 3 - Gear Pump
4	Transmission
5	Engine

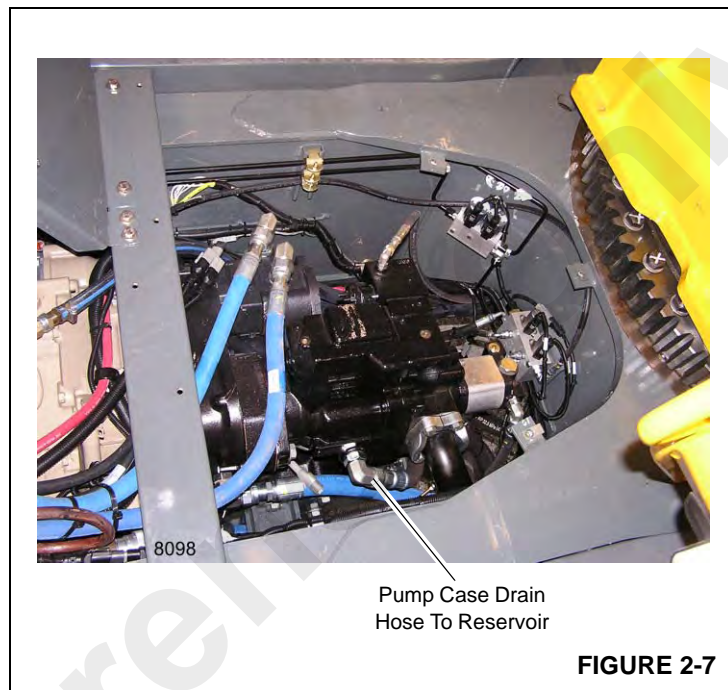

PRESSURE SETTING PROCEDURES

The following procedures should be used to properly check, adjust and set the hydraulic system pressures.

NOTE: A Digital Pressure Gauge and accessories may be purchased through Manitowoc Crane Care.

The following equipment is required for checking the hydraulic pressure settings.

- Pressure Gauge
- Three dial gauge 0-34.5 MPa (0-5000 psi)
- Pressure check diagnostic quick disconnect - Grove P/N 9999101806 and straight adapter fitting 7447040401
- ORFS reducers as required to attach work port hoses to the gauge.

NOTE: When checking the directional control valve relief settings, unless otherwise specified, start with the engine at idle RPM and move the controller to its fully stroked position. Then slowly accelerate the engine to the specified RPM. Read gauge and make adjustments to specified setting.

When checking the outrigger relief valve setting, start with the engine at idle RPM and activate and hold the extend switch. Then slowly accelerate the engine to the specified RPM. Read gauge and make adjustment as required.

NOTE: GP (Gauge Port) and number corresponds to gauge ports on the valve and on the hydraulic schematic.

Table 2-1
Valve Pressure Setting Table

Valve To Be Set	Pressure Setting PSI (MPa)	Tolerance PSI (MPa)	Adjustment Location
Hoist (s), and Lift Pressure Setting	4000 (27.6)	± 50 (0.4)	GP2 - Superstructure mounted main directional control valve load sense relief valve (Figure 2-9)
Telescope Extend Pressure Setting	3500 (24.1)	± 50 (0.4)	GP7 - Superstructure mounted main directional control valve port relief valve (Figure 2-10)
Telescope Retract Pressure Setting	3250 (22.4)	± 50 (0.4)	GP7 - Superstructure mounted main directional control valve port relief valve (Figure 2-10)
Outrigger Extend/Retract/Rear Steer/Oil Cooler Motor Pressure	2500 (17.3)	± 50 (0.4)	GP2 - Carrier mounted outrigger control manifold (Figure 2-11)
Swing Left and Right Work Port Relief Pressures	2100-2450 (14.5 - 16.9)	See Range	GP1 - Superstructure mounted accessory manifold with swing directional control valve (Figure 2-9)
Front Steer Pressure Setting	2500 (17.3)	± 50 (0.4)	GP5 - Superstructure mounted accessory manifold with swing directional control valve (Figure 2-9)
Swing Brake Supply Pressure Setting	250 - 275 (1.7 - 2.1)	See Range	GP4 - Superstructure mounted accessory manifold with swing directional control valve (Figure 2-9)
Pilot Supply Pressure Setting	2500 - 2550 (17.3 - 17.6)	See Range	GP3 - Superstructure mounted accessory manifold with swing directional control valve (Figure 2-9)
Non-CE Cranes Piston Pump Δ P Pressure Setting	325 - 400 (2.2 - 2.8)	See Range	GP2 - Carrier mounted piston pump (Figure 2-13)
CE Cranes Piston Pump Δ P Pressure Setting	525 - 550 (3.6 - 3.8)		
Service Brake High Charge Limit	2320 (16.0)	+72, -145 (0.5) (1.00)	GP7 (Figure 2-10) Non-adjustable
Service Brake Low Charge Limit	1950 (13.5)	±145 PSI (1.00)	GP7 - (Figure 2-10) Non-adjustable
Service Brake Accumulator Pre-charge	800 - 850 (5.5 - 5.8)	See Range	Accumulator (Figure 2-12)

NOTE: Procedures A through H in the following text correlate with Figures 2-6 through 2-10.

Procedure A - Checking/Setting the Main Control Valve for Hoist(s), Boom Lift and Piston Pump

NOTE: Procedure A for max. and ΔP settings.

Set hoist(s) and boom lift as follows:

1. Install pressure check diagnostic quick disconnect with gauge onto test nipple @ the GP2 Port of the accessory manifold with swing directional control valve (Figure 2-9).
2. Assure piston pump cut-off max.(Figure 2-13) factory setting is correct. Loosen the jam nut on the cut-off max adjusting screw and turn it in until it softly seats or bottoms out. Then back the adjusting screw out 1/4 to 1/2 turn and lock in place with jam nut. This will ensure that full system pressure of 27.6 MPa (4000 psi) can be obtained in step #4.
3. Assure piston pump ΔP (stand-by) factory setting is correct. With diagnostic quick disconnect still installed @ the GP2 port of the accessory manifold with swing directional control valve (Figure 2-9), start engine and @ idle RPM adjust the piston pump differential setting screw "in" to increase or "out" to decrease so that a gauge reading of 2.2 - 2.8 MPa (325 - 400 psi) (Figure 2-13). For CE machines, this pressure is 3.6-3.8 MPa (525-550 psi)
4. If the lift cylinder is not installed, plug the extend hose (the larger of the two). If lift cylinder is installed, omit this step and continue to step #5.
5. With diagnostic quick disconnect still installed @ the GP2 port of the accessory manifold with swing directional control valve (Figure 2-9), start engine and throttle up to full RPM. Feather into the boom lift controller to full controller stroke (up or down) and hold. If the boom is installed, boom up to max elevation and hold or boom down to minimum elevation and hold. Adjust the load sense relief valve "in" to increase or "out" to decrease so that a gauge pressure reading of 27.6 \pm 0.4 MPa (4000 \pm 50 psi) is achieved (Figure 2-10).
6. Stop engine and remove the diagnostic couplers from the test nipples

Set telescope extend and retract as follows:

Extend

7. If boom is not installed, install a pressure check diagnostic quick disconnect with gauge onto test nipple @ the GP7 port of the main directional control valve (Figure 2-10).

8. Cap hose (the larger of the two) running from port A, telescope section of the main directional control valve to the cylinder port block at the back of the base section.
9. Start engine and throttle up to full RPM. Attempt to telescope OUT by feathering into the controller to full controller stroke. Adjust the work port relief "in" to increase or "out" to decrease so that a gauge pressure of 24.2 \pm 0.4 MPa (2700 \pm 50 psi) is achieved (Figure 2-10).
10. If the boom is installed, start engine and throttle up to full RPM. Telescope out to fully extend the boom and hold. Adjust the work port relief valve "in" to increase or "out" to decrease so that a gauge pressure reading of 24.2 \pm 0.4 MPa (3500 \pm 50 psi) is achieved (Figure 2-10).

11. Stop engine and remove pressure gauge and re-connect plumbing.

Retract

12. If the boom is not installed, install a pressure check diagnostic quick disconnect with gauge onto test nipple @ the GP7 port of the main directional control valve (Figure 2-10).
13. Cap hose (the smaller of the two) running from port B, telescope section of the main directional control valve to the cylinder port block at the back of the base section.
14. Start engine and throttle up to full RPM. Attempt to telescope IN by feathering into the controller to full controller stroke. Adjust the work port relief valve "in" to increase or "out" to decrease so that a gauge pressure reading of 22.5 \pm 0.4 MPa (3250 \pm 50 psi) is achieved (Figure 2-10).
15. If the boom is installed, start engine and throttle up to full RPM. Telescope in to fully retract the boom and hold. Adjust the work port relief valve "in" to increase or "out" to decrease so that a gauge pressure reading of 22.5 \pm 0.4 MPa (3250 \pm 50 psi) is achieved (Figure 2-10).
16. Stop the engine and remove pressure gauge and re-connect plumbing.

Procedure B - Setting The Outrigger/Rear Steer/Oil Cooler Motor Pressures

1. Install a pressure check diagnostic quick disconnect with gauge onto test nipple at G2 port of the outrigger control manifold (Figure 2-11).
2. Start engine and throttle up to full RPM. Select and activate the outrigger "extend or retract" switch on the cab dash. Adjust the pressure reducing valve integrated in the outrigger control manifold "in" to increase or "out" to decrease so that a gauge pressure of 17.3 MPa \pm 0.4 (2500 \pm 50 PSI) is achieved (Figure 2-11).
3. Stop engine. Remove the diagnostic coupler.

Procedure C - Checking/Setting the Swing Directional Control Valve Work Port Relief Valves

1. With engine off, Install a pressure check diagnostic coupler with gauge onto test nipple at GP1 port of the accessory manifold with swing directional control valve (Figure 2-9).
2. Start engine, throttle up to full RPM. With the swing house lock engaged, swing full right and hold controller. Adjust the "B" port work port relief "in" to increase or "out" to decrease so that a gauge pressure reading of 14.5 - 16.9 MPa (2100 - 2450 psi) is achieved.
3. Repeat step #2 for swing left adjusting the "A" port relief.

Procedure D - Checking/Setting the Service Brake Dual Accumulator Charge Valve Charging Limits

1. With engine off, discharge all of the pressurized fluid stored in the accumulators by depressing the service brake pedal on the cab floor 8 - 10 times.
2. Install a pressure check diagnostic quick disconnects with gauge onto test nipple at GP7 port of the main directional control valve (Figure 2-10).
3. Start engine and idle. The charging valve will immediately start to charge the accumulators. Watch the pressure gauge. The high charge limit should read 17.4 MPa +0.5- 1.00 (2320 +72, -145 psi) when the pressure stops rising. This accumulator charge valve is non-adjustable.
4. With the engine still at idle, repeatedly depress the service brake pedal on the cab floor until the gauge pressure reads approximately 14.5 ± 1.00 MPa (2100 ± 145 psi) when it starts to recharge. Once you have found this pressure, push the brake pedal again to recharge. Watch the gauge and verify the low charging limit to be 13.5 ± 1.00 MPa (1950 ± 145 psi) (when it starts to recharge). This accumulator charge valve is non-adjustable.
5. Stop engine. Remove pressure gauge.

Procedure E - Checking/Pre-Charging the Service Brake Accumulators

1. With the engine off, discharge all of the pressurized oil stored in the accumulators by depressing the service brake pedal on the cab floor 4-6 times. Remove the gas valve guard and cap on the accumulator (Figure 2-13)
2. Before attaching the gas charging assembly (Figure 2-13) onto the gas valve, back the gas chuck "T" handle all the way out (counterclockwise).

3. Close the charging assembly bleed valve. Attach the swivel nut onto the gas valve and tighten 1.1 - 1.6 Nm (10-15 lb-in).
4. Turn the gas chuck "T" handle all the way down (clockwise) which will depress the core in the gas valve
5. Check the pre-charge pressure. The gauge should read 5.5 - 5.9 MPa (800 - 850 psi).
6. If the pressure is 5.5 - 5.9 MPa (800 - 850 psi), remove the charging valve assembly by turning the "T" handle all the way out on the gas chuck and then opening the bleed valve (Figure 2-13). If the pressure is low, see pre-charging procedure below.
7. Secure the gas valve, loosen the swivel nut and remove the charging assembly. Replace the gas valve cap and guard.

Procedure For Pre-charging the Accumulator, If required

1. With the engine off, discharge all of the pressurized oil stored in the accumulators by depressing the service brake pedal on the cab floor 4 - 6 times. Remove the gas valve guard and cap on the accumulator (Figure 2-12).
2. Ensure the nitrogen supply bottle is shut off, then attach the charging valve assembly to it.
3. Before attaching the charging assembly to the accumulator gas valve, back the gas chuck "T" handle all the way out (counterclockwise).
4. Close the charging assembly bleed valve. Without looping or twisting the hose, attach the swivel nut to the accumulator gas valve and tighten 1.1 - 1.7 Nm (10-15 lb-in).
5. Turn the gas check "T" handle all the way down (clockwise) which will depress the core in the gas valve.
6. Slowly open the nitrogen bottle valve and fill the accumulator. Close the valve when the pre-charge is 5.5 - 5.9, MPa (800 - 850, psi).
7. If the precharge is higher than specified in step #6, close the nitrogen bottle and slowly open the bleed valve on the charging assembly (Figure 2-12) until the pressure is to specification.
8. Remove the charging valve assembly by turning the "T" handle all the way out (counterclockwise) on the gas check and then open the bleed valve.
9. Secure the gas valve, loosen the swivel nut and remove the charging assembly. Replace the gas valve cap and guard.

Procedure F - Checking/Setting the Front Steer Pressure

1. Install pressure check diagnostic quick disconnect with gauge onto test nipple @ GP5 port of the accessory manifold with swing directional control valve (Figure 2-9).
2. Start engine and throttle up to full RPM. Fully turn the steering wheel left or right against the axle stop. Adjust the steering load sense relief valve in the accessory manifold with swing directional control "in" to increase or "out" to decrease so that a gauge pressure of 17.3 MPa (2500 psi) is achieved (Figure 2-9).
3. Stop engine. Remove diagnostic couplers.

Procedure G - Checking/Setting the Pilot Supply Pressure

1. Install pressure check diagnostic quick disconnect with gauge onto test nipple @ GP3 port of the accessory manifold with swing directional control valve (Figure 2-9).
2. Start engine and @ idle RPM, lower left armrest, fully stroke and hold the boom lift raise or lower joystick. Adjust the pilot pressure reducing valve of the accessory manifold with swing directional control valve "in" to increase or "out" to decrease so that a gauge pressure of 17.3 - 17.6 MPa (2500 - 2550 psi) is achieved (Figure 2-9).
3. Stop engine. Remove diagnostic couplers.

Procedure H - Checking/Setting the Swing Brake Release Pressure

1. Install pressure check diagnostic quick disconnect with gauge onto test nipple @ GP6 port of the accessory manifold with swing directional control valve (Figure 2-9).
2. Start engine and idle, select and depress the swing brake release switch and adjust the swing brake pressure reducing valve "in" to increase or "out" to decrease so that a gauge pressure of 1.7 - 2.1 MPa (250 - 275 psi) is achieved (Figure 2-9).
3. If adjustment can't obtain the setting in step #2, stop engine and install a pressure check diagnostic quick disconnect with gauge onto the test nipple @ the GP2 at the accessory manifold valve (Figure 2-10). Follow procedure A step 3 to set pump stand-by and then repeat this step.
4. Stop engine. Remove diagnostic couplers.

Procedure J - Setting Threshold on Electronic Controllers

1. Attach laptop to diagnostic connector in cab and make sure CAN C is selected (position 3 on CAN selector knob) (Figure 2-8).
2. Open the CCS Crane Service Tool. From the menu bar, select Settings->Crane Model->Auto Detect. The auto detection procedure should detect RT->RT540i/RT530i->Superstructure.
3. Start engine and run at @ idle rpm's, make sure to lower left armrest.
4. For each function, attach a test fitting and pressure gauge in the Pilot End Caps one at a time: GPA for Main Hoist Up, GPB for Aux Hoist Up, GPC Tele Retract, GPD Lift Down (Figure 2-10).
5. Current range settings for each function can be found in the Crane Service Tool in the menu bar under View->Superstructure. Select the function and a child window will open. Select the Speed Control solenoid icon, normally located in the lower left of the window. An example is shown for Main Hoist (Figure 2-8).
6. Adjust the max current for Main Hoist Up (Figure 2-10). Move the joystick to the full on position and monitor the pressure gauge and adjust the I_{max} [mA] to reach 295psi then adjust to 300psi +0/-5psi. Note that you will need to press the Set button at the bottom of the window before it will take effect.
7. Next set the current threshold of Main Hoist Up. Monitor the pressure gauge and move the joystick just off center for Main Hoist in the up position. Watch the pressure gauge, move until it reaches approx 100 PSI. Hold the joystick at this position and note the value for MH Solenoid Current in the Main Hoist Data window. Enter this setting for I_{min} [mA] and press the green Set button at the bottom of the window.
8. Repeat this process for Aux Hoist Up (GPB,) Tele Retract (GPC,) and Boom Down (GPD) (Figure 2-10)
9. Next adjust the slew brake current range. Attach test fitting and pressure gauge GP4 (Figure 2-9) port with engine running at idle. Fully depress swing brake pedal. Monitor the press gauge and adjust the swing brake solenoid I_{max} [mA] setting to reach to reach 250 PSI. Next slowly depress swing brake pedal down until you reach 25 PSI on the gauge. Note the swing brake current value, and set I_{min} [mA] to this value.
10. After setting all of the functions, save the EE configuration to the controller's Factory and Customer settings area. This is done by selecting Tools->Calibration and Adjustment->EEPROM and pressing the Save active to Customer and Save active to Factory buttons.

11. Next save the configuration to a file by right clicking on the 'Active' column and Write->Write column to file from the context menu. Save the file in a folder under the

model designation (In this case RT540E). Name the file as follows: (Sales order number_Date). Sample: (123456_2006aug17)

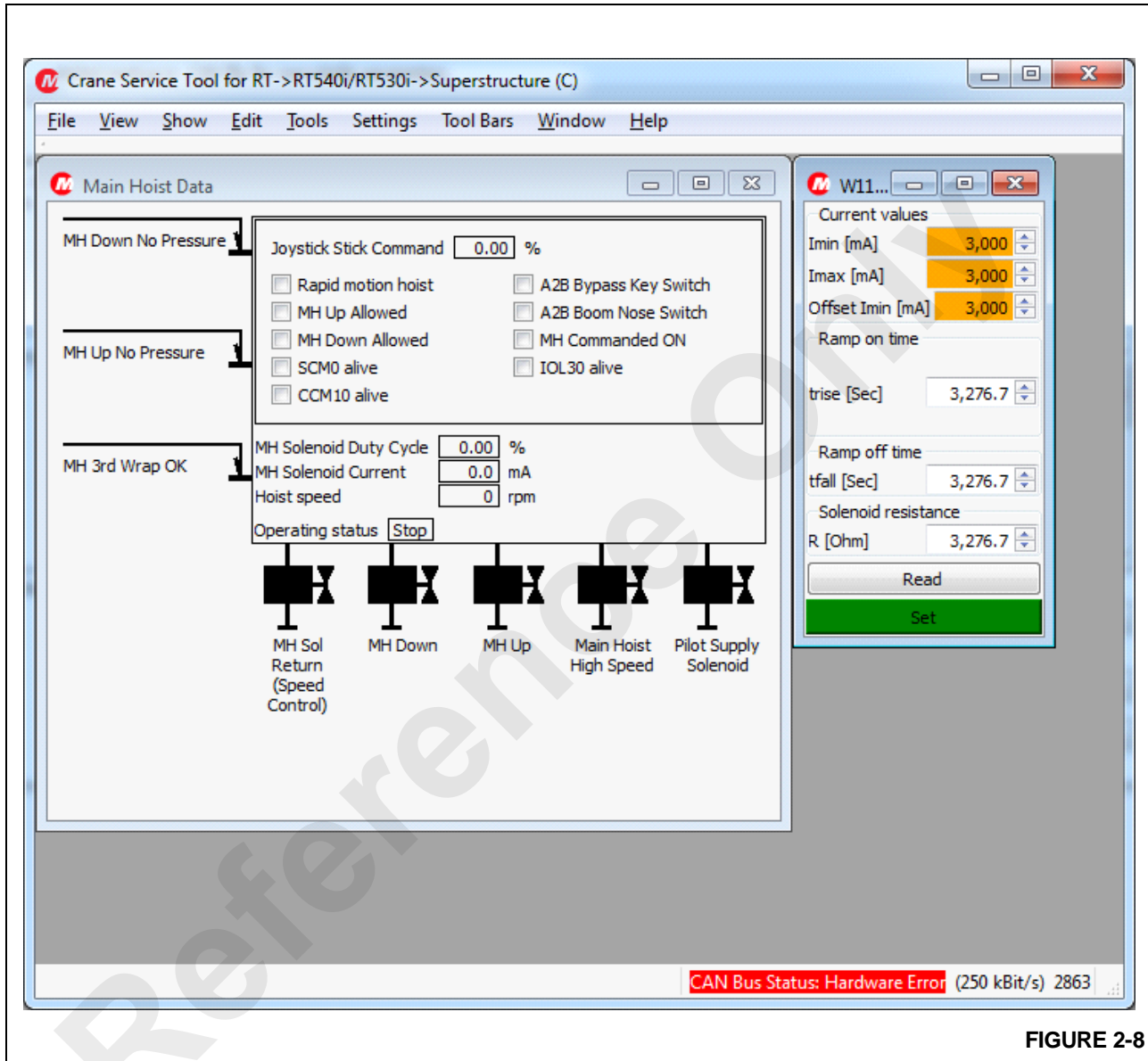

FIGURE 2-8

Item	Description
1	Procedure G- Pilot Supply PSI Reducing Valve
2	Procedure H - Swing Brake PSI Reducing Valve
3	Procedure C - Swing Left Port Relief Valve
4	Procedure F - Front Steer Load Sense Relief Valve
5	Procedure C - Swing Right Port Relief Valve
6	Gauge Port 2
7	Gauge Port 3
8	Gauge Port 6
9	Pilot End Cap GP8 - Swing Left
10	Pilot End Cap GP9 - Swing Right

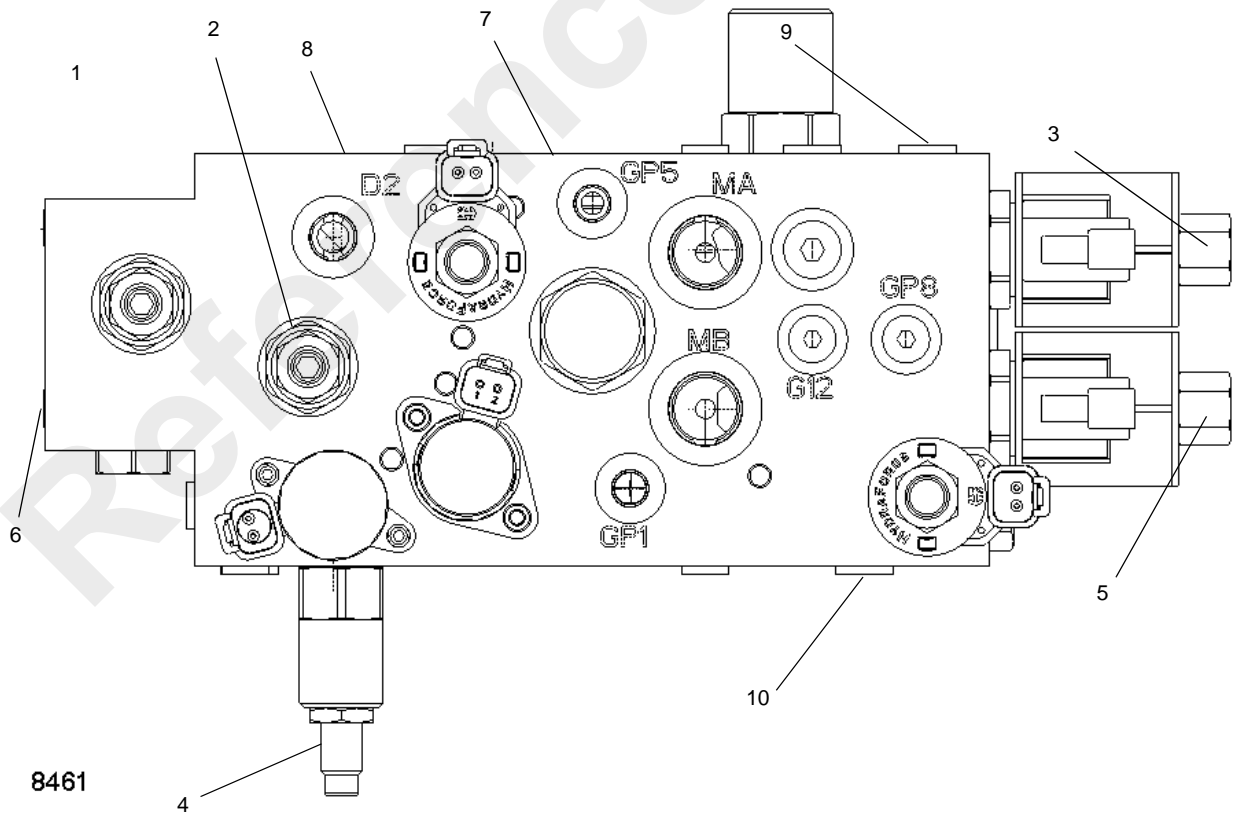
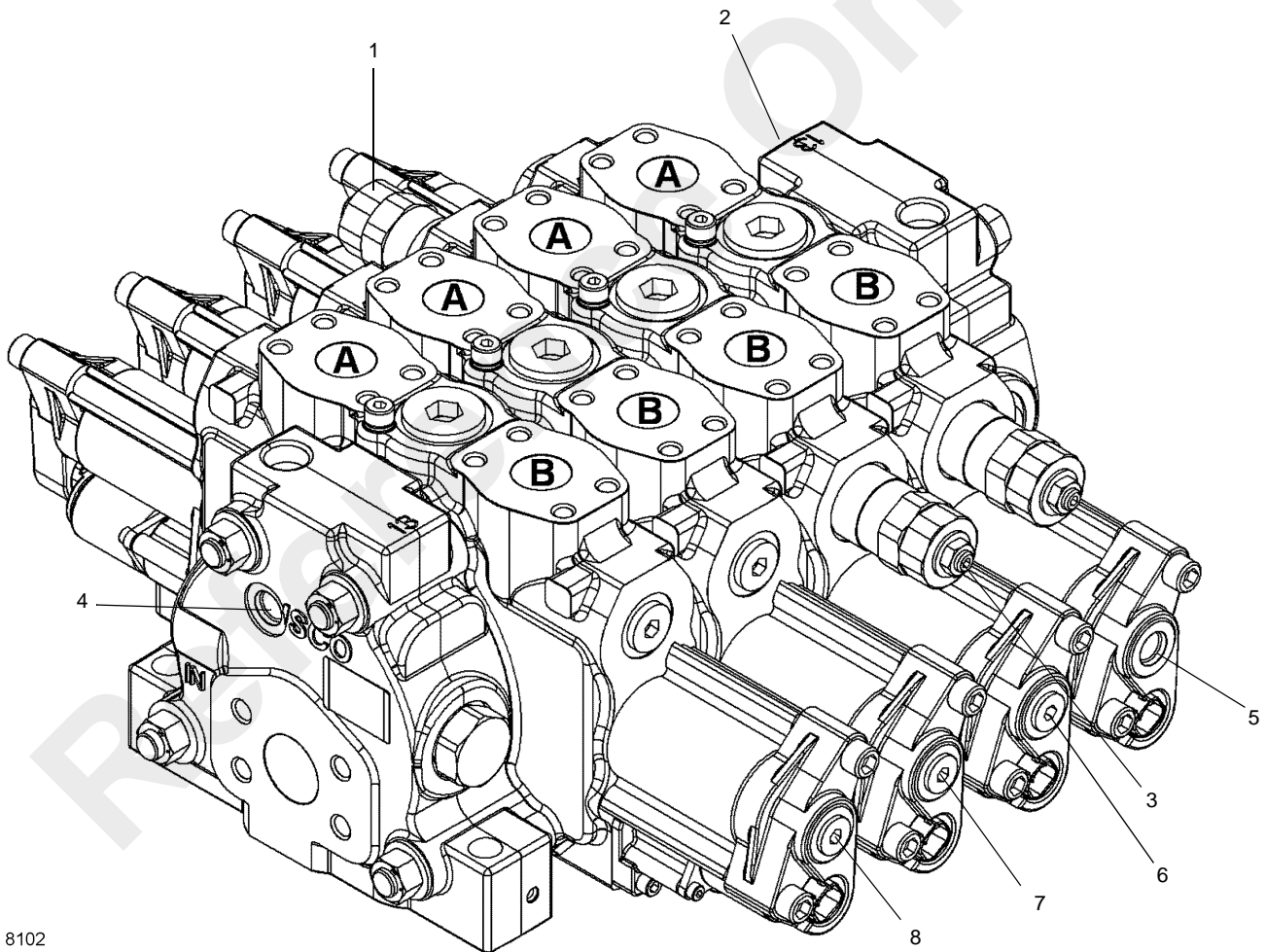

FIGURE 2-9

Item	Description
1	Procedure A - Telescope Extend Port Relief
2	Procedure A - Load Sense Relief Valve
3	Procedure A - Telescope Retract Port Relief
4	Gauge Port 7
5	Pilot End Cap GPD Lift Down
6	Pilot End Cap GPC Telescope Retract
7	Pilot End Cap GPA Main Hoist Up
8	Pilot End Cap GPB Aux Hoist Up



8102

FIGURE 2-10

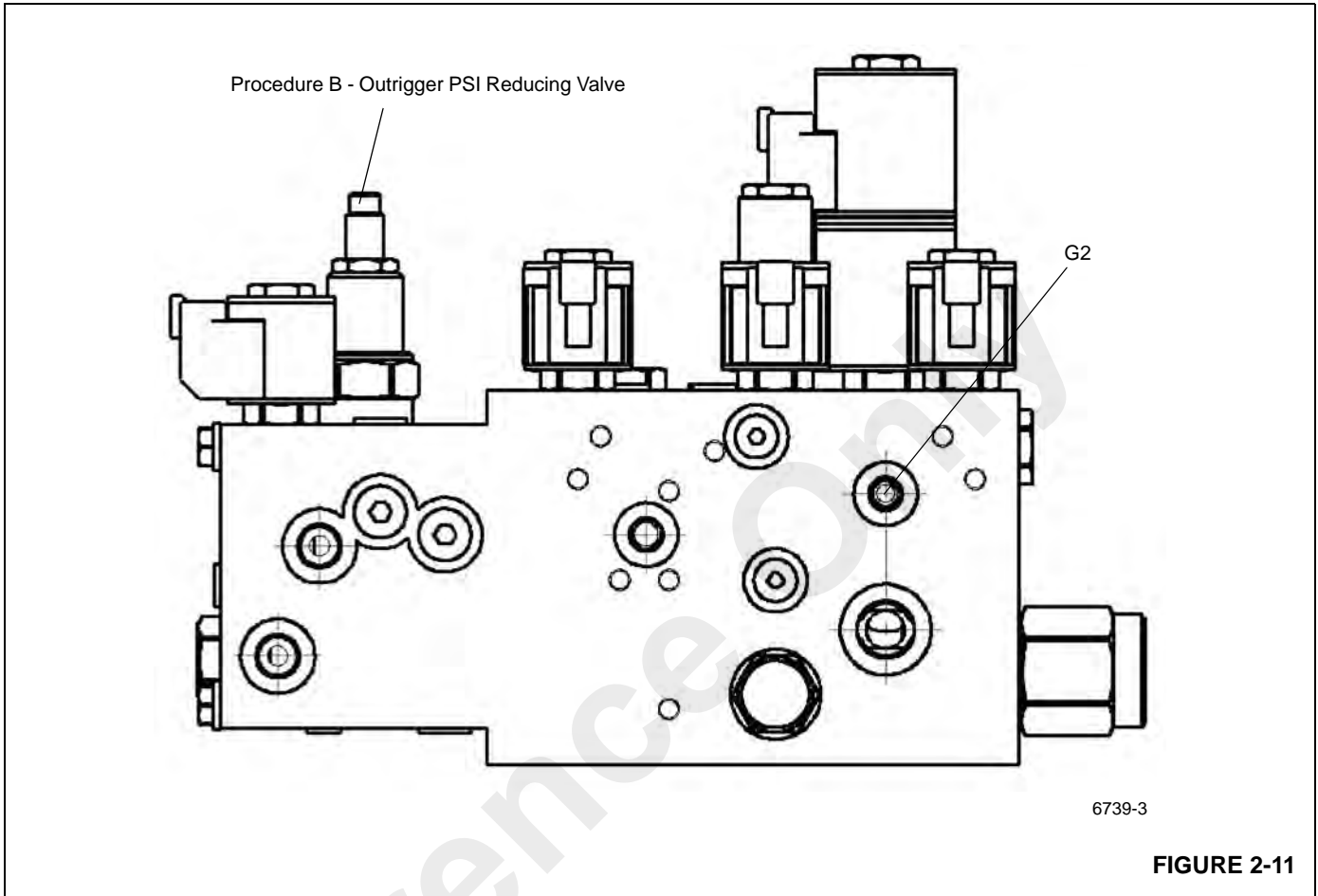
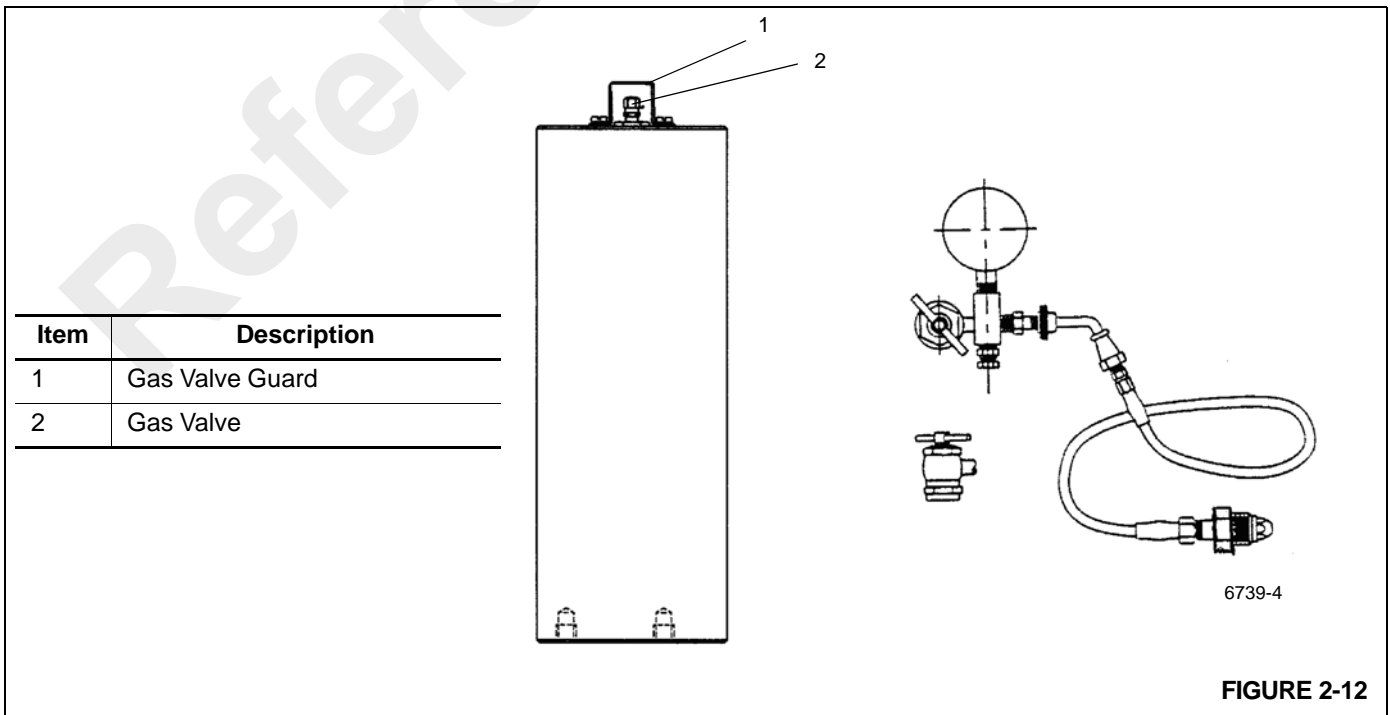

FIGURE 2-11



6739-4

FIGURE 2-12

Item	Description
1	Procedure A - Pump Cut-Off Max Setting Adjustment
2	Procedure A - Pump ΔP (Stand-by) Adjustment

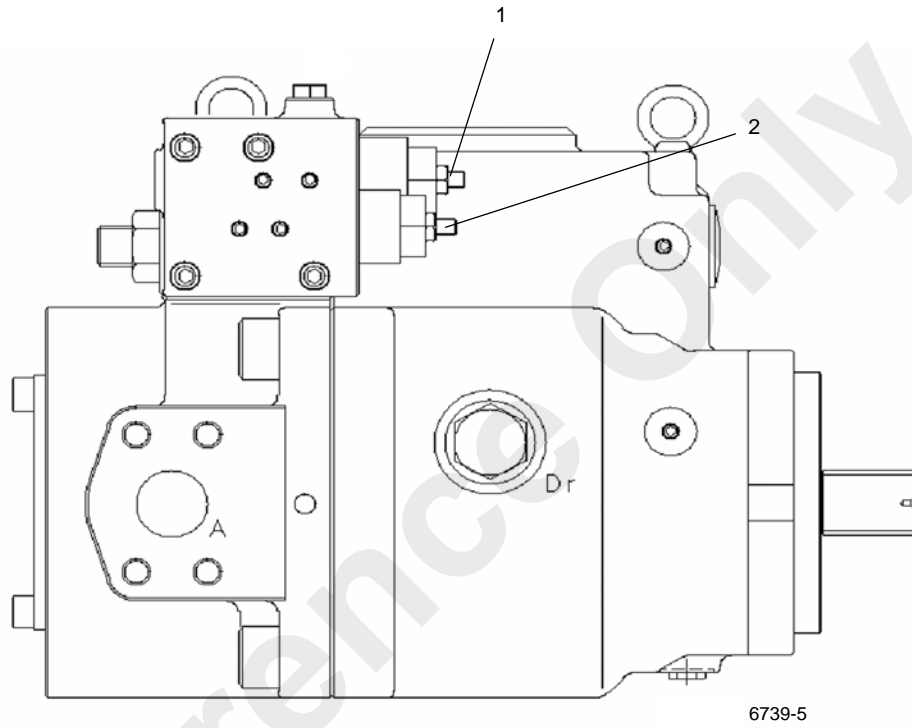

FIGURE 2-13

VALVES

General

This subsection provides descriptive information for all the hydraulic valves used on this crane. For a listing of all valves, the circuit they are used in and their physical location, refer to (Table 2-2). Refer to (Figure 2-14) for valve locations. The

description of each valve given here is for the valve itself. For information on how each valve functions in the individual circuits, refer to the description and operation procedures of that circuit.

NOTE: On each valve illustration in this section, each item number in table correlates to location on the valve, and to the valve hydraulic schematic.

**Table 2-2
Valve Usage Table**

Valve Name	Circuit Used In	Physical Location
Directional Control Valves	Boom Lift/Telescope(s)/Hoist(s) Swing/Steer	Superstructure Right Side Plate Superstructure Right Side Plate
Steering Control Valve	Front Axle Steer Control	Cab Steering Column
Front Steer/Swing/Accessory Manifold	Front Axle Steer Supply Swing Directional Control Swing Brake Release Pilot Supply	Superstructure Right Side Plate
Tandem Brake Valve with Treadle	Service Brakes	Cab Floor
Dual Accumulator Charging Valve	Service Brakes	Superstructure Left Side Plate
Accumulator(s)	Service Brake	Rear Superstructure
Holding Valves	Boom Lift Telescope (3) Counterweight Removal (2)	Lift Cylinder (Bolt on Manifold) Cylinder Port Blocks (Cartridge style) Cylinder Port Blocks (Cartridge style)
Axle Lockout, Rear Steer and Oil Cooler Fan Motor Control Manifold	Axle Lockout Control Rear Steer Control Oil Cooler Motor Control	Left Hand Carrier Frame Rail
Solenoid Valves: Cross Axle Differential Lock	Differential Lock (Optional)	Carrier Inside Right Side Rail
Hoist Motor Control Valve	Hoist(s)	Both Hoists (see Hoist section)
Check Valves	Return Circuit	One in Parallel With Oil Cooler
Outrigger Control Manifold	Outrigger	On Front and Rear Face of Carrier Frame Front and Rear Cross Member
Pilot Operated Check Valve	Outrigger	Port Block of each Jack Cylinder (4)
Cross Axle Differential Lock Valve	Differential Lock (Optional)	Carrier Bulkhead Plate Forward Of The Engine
Range Shift and Parking Brake Valve	Parking Brake Axle Disconnect	Center of Rear Frame

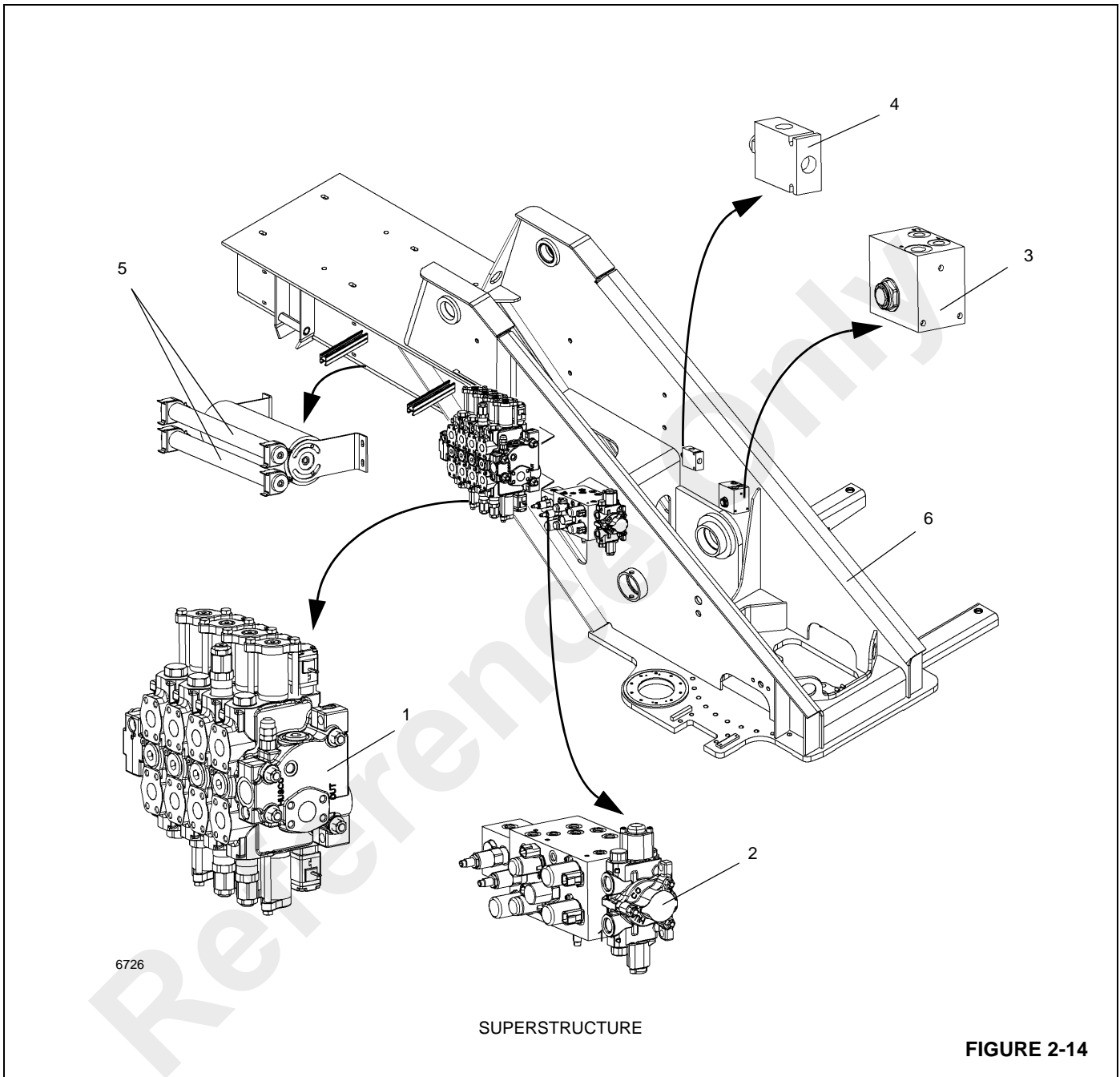

1	Hoist/Telescope/Lift Directional Valve	4	Secondary Steer Valve (CE Option)
2	Swing/Steer Directional Valve	5	Accumulator
3	Service Brake Dual Accumulator Charge Valve	6	Superstructure

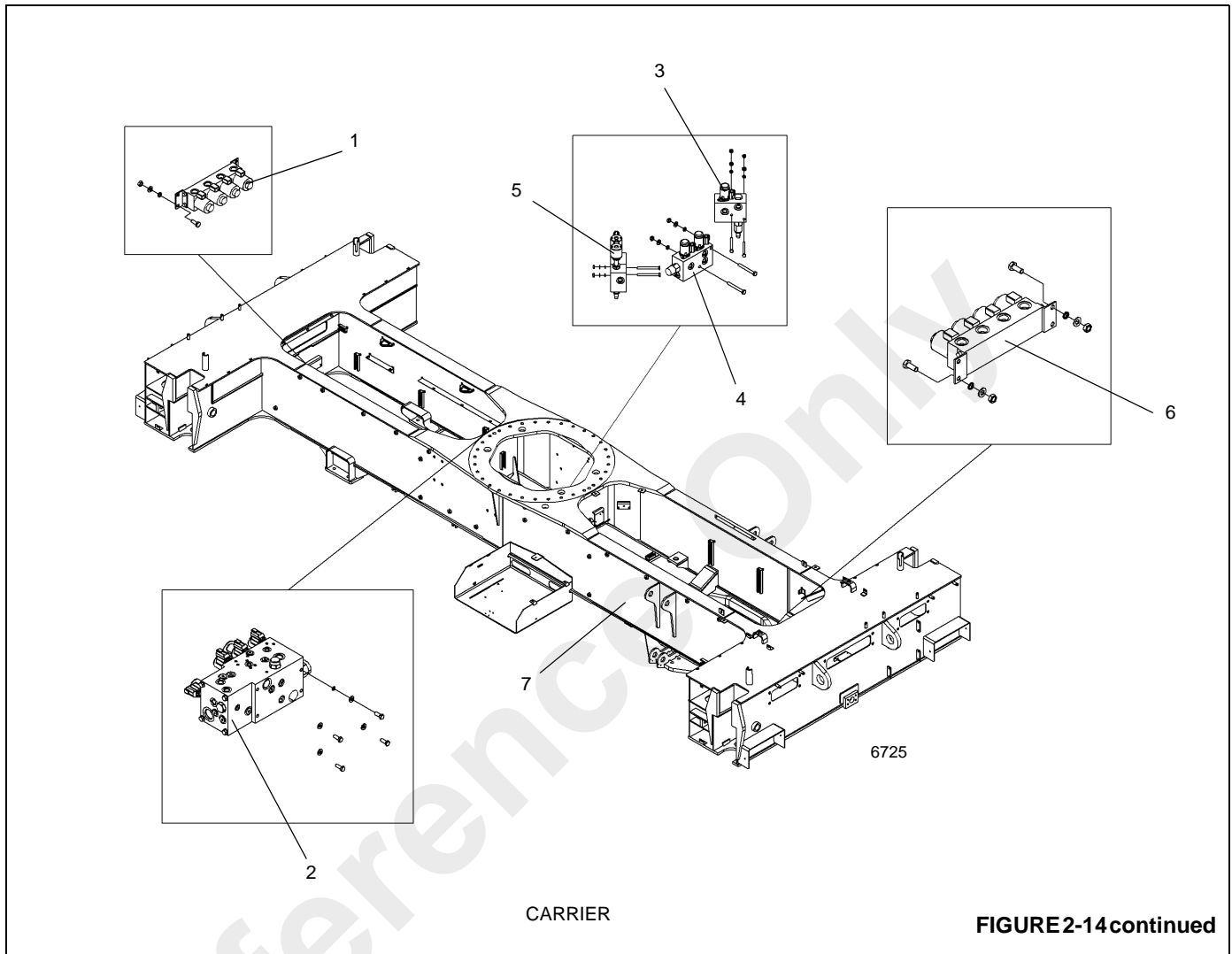

FIGURE2-14continued

1	Front Outrigger Control Manifold	5	Axle Lockout Valve
2	Outrigger/Rear Steer Valve	6	Rear Outrigger Control manifold
3	Differential Lock Valve	7	Frame
4	Park Brake Range Shift Valve		

DIRECTIONAL CONTROL VALVES

Description

The directional control valves direct and control hydraulic oil flow from the pumps to the boom lift and telescope cylinders, each hoist motor, the swing motor, and the front steer cylinders from the front steer control valve. The boom lift/telescope/hoist directional control valve (Figure 2-15) is located on the outside of the right superstructure side plate. The valve bank is removed and installed as an assembly.

The boom lift/telescope/hoist control valve is a three position, four way pressure compensated, closed center directional valve. It receives pump flow from hydraulic swivel port 6 and pump No. 1. Lift, telescope and hoist (s) functions are controlled by proportional two position two way solenoid cartridges installed into the valve's casting under each spool. These valves receive an electrical signal from the controllers on the cab armrest.

RCL lockout is achieved by de-energizing the proportional solenoids.

The inlet section of the boom lift/telescope/hoist directional control valve contains a load sense relief valve set at 27,579 kPa/275.7 bar (4000 psi) protecting the main and auxiliary hoist and boom lift sections. The boom lift retract has a thermal port relief set of 29,647.4kPa/296.4 bar (4300 psi). The telescope section has port reliefs set at 18,616 kPa/186.2 bar (2700 psi) and 20,684 kPa/207 bar (3000 psi).

The swing directional control valve is installed on the outside of the right superstructure side plate. Refer to *Accessory With Swing Directional Control Manifold*, page 2-33.

Maintenance

Boom Lift/Telescope/Hoist Valve Bank Removal

1. Tag and disconnect all of the electrical connectors from the valve.
2. Tag and disconnect the hydraulic lines from the valves. Cap or plug the lines and ports.

NOTE: The lift/telescope/hoist valve bank weighs approximately 81.30 kg (179.2 pounds).

3. Remove the capscrews, washers and nuts securing the valve bank and remove the valve bank.

Boom Lift/Telescope/Hoist Valve Bank Installation

1. Place the valve bank on the superstructure side plate and secure it with the capscrews, washers and nuts. Torque the capscrews see *Fasteners and Torque Values*, page 1-11.
2. Connect the hydraulic lines to the valves as tagged during removal.
3. Connect the electrical connectors as tagged during removal.

Functional Check (All Valve Banks)

1. Start the engine and run it at normal speed.
2. Operate the control levers of the valve bank(s). Check for smooth operation of cylinders and motors.
3. Check the valve bank(s) and lines for leakage. Make repairs as needed.

Function Check - RCL Lockout Valves

1. Remove circuit breaker F12 from the power panel in the cab. This cuts off power to the RCL.
2. Start the engine.
3. Try to telescope the boom out, lower the boom, hoist up the main hoist, and hoist the auxiliary hoist up (if installed). Verify none of these functions work.
4. Shut down the engine. Reinstall F12.
5. Telescope the boom out, lower the boom, hoist up the main hoist, and hoist the auxiliary hoist up (if installed). Verify all of these functions work.
6. Check for leaks. Make repairs as needed.

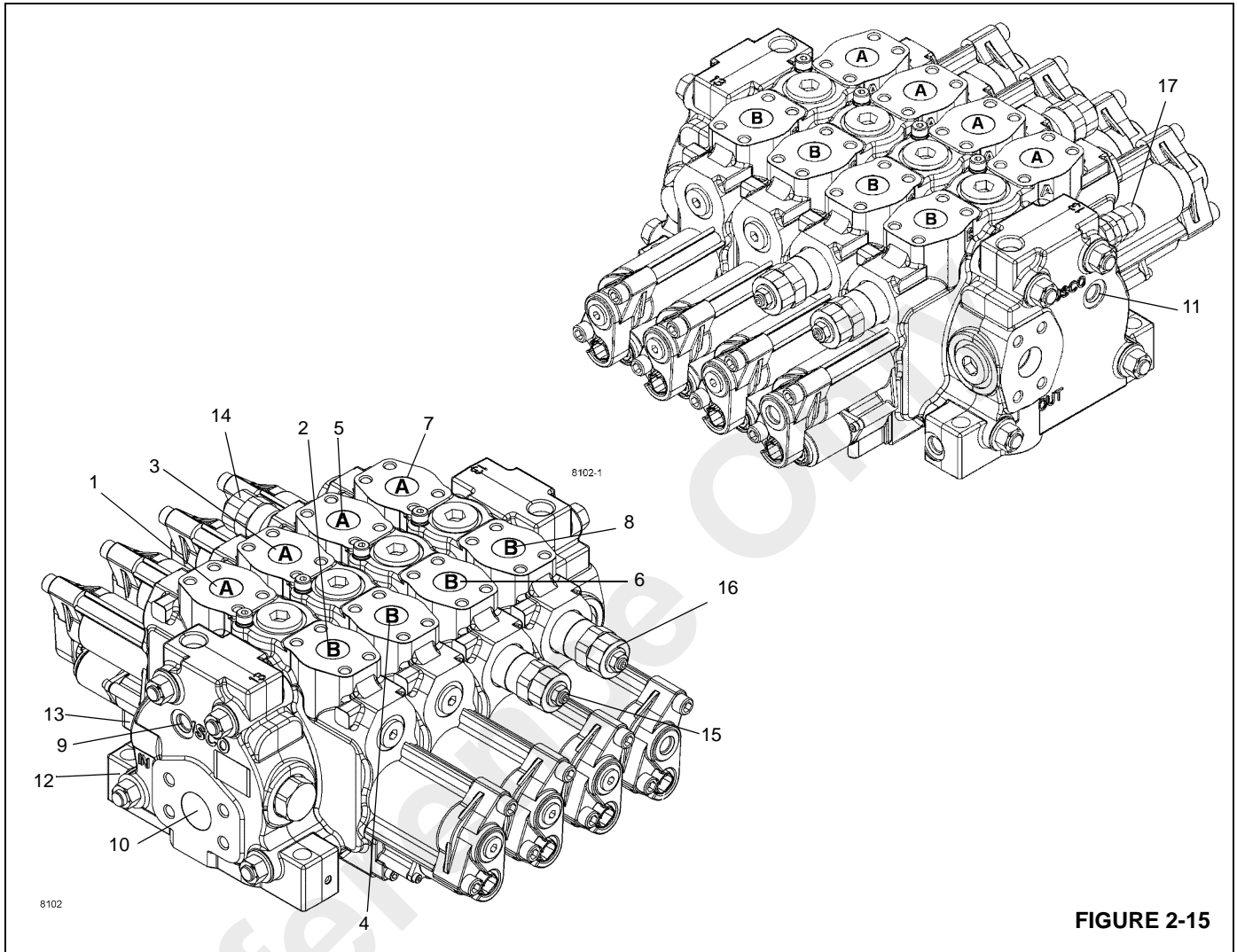
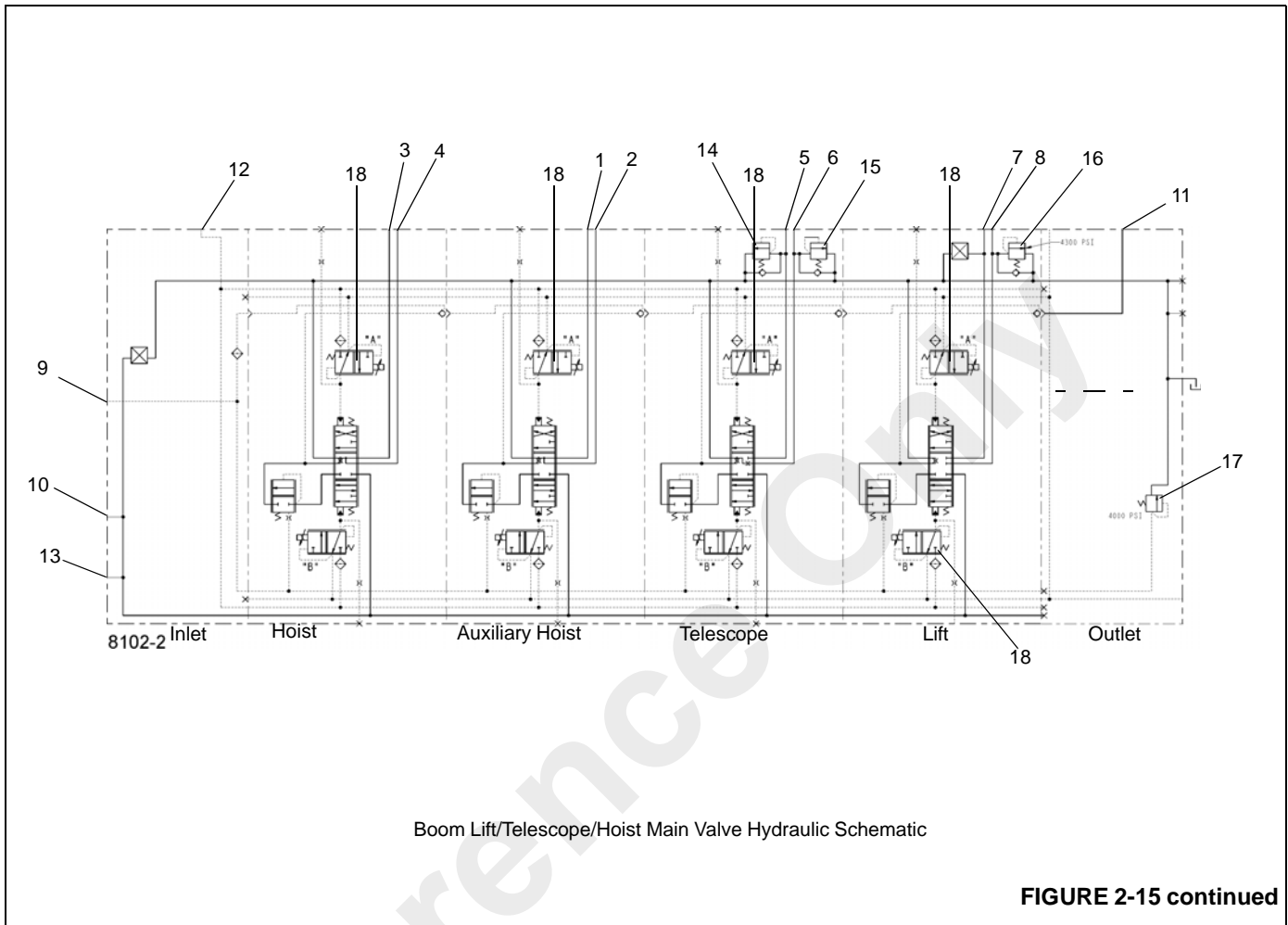

FIGURE 2-15

1	Port 1A - Main Hoist Up	10	Port P1 - From Swivel Port 6
2	Port 1B - Main Hoist Down	11	Load Sense - Inlet Port
3	Port 2A - Aux Hoist Up	12	Port PS - Pilot Supply
4	Port 2B - Aux Hoist Down	13	Gauge Port
5	Port 3A - Telescope Extend	14	Relief Valve - Telescope Extend
6	Port 3B - Telescope Retract	15	Relief Valve - Telescope Retract
7	Port 4A - Lift Up	16	Relief Valve - Lift
8	Port 4B - Lift Down	17	Relief Valve - Load Sense
9	Load Sense - Outlet Port		



ACCESSORY WITH SWING DIRECTIONAL CONTROL MANIFOLD

Description

The accessory manifold with swing directional valve (Figure 2-16) is located on the right side of the turntable. The manifold contains two adjustable pressure reducing valves, five 3-way two position solenoid valves, a 3-way four position swing directional valve, and a check valve.

One pressure reducing valve provides 1.72 MPa (250 psi) for operation of the swing brake. The other provides 17.2 MPa (2500 psi) for the pilot circuit.

Each solenoid valve is held in its normally closed position by a spring. When the solenoid is energized, the plunger assembly forces the spool to shift, causing the valve to shift. De-energizing the solenoid causes spring pressure to shift the spool to its normally closed position.

One two position, three way solenoid valve serves as the swing brake release valve. This normally closed valve, when de-energized, prevents hydraulic oil pressure from releasing the swing brake. When the swing brake switch is off, this valve opens to allow hydraulic oil pressure to release the swing brake.

One proportional two position, three way solenoid valve actuated by the cab swing foot brake proportionally supplies pressurized oil to the swing drive brake.

The three position four-way swing directional valve is installed onto the manifold. Both swing working ports have check valves that are flooded by a.41 MPa (60 psi)

resistance check valve providing make-up oil to the swing motor for motor over-run when the valve is centered. It receives oil from pump #1 through swivel port 5. This section is controlled by two proportional two position, three way solenoid valves. These valves receive an electrical signal from the cab armrest controllers.

Maintenance

Removal

1. Tag and disconnect all of the electrical connectors or manual control levers.
2. Tag and disconnect the hydraulic lines from the valves. Cap or plug the lines and ports.

NOTE: The swing/steer/brake valve manifold weighs approximately 10.0 kg (22.0 lb).

3. Remove the capscrews, lockwashers and flatwashers securing the manifold. Remove the manifold.

Installation

1. Place the manifold on the superstructure side plate and secure with the capscrews, lockwashers and flatwashers. Torque the capscrews see *Fasteners and Torque Values*, page 1-11.
2. Connect the hydraulic lines to the valves as tagged during removal.
3. Connect the electrical connectors to the valve as tagged during removal.

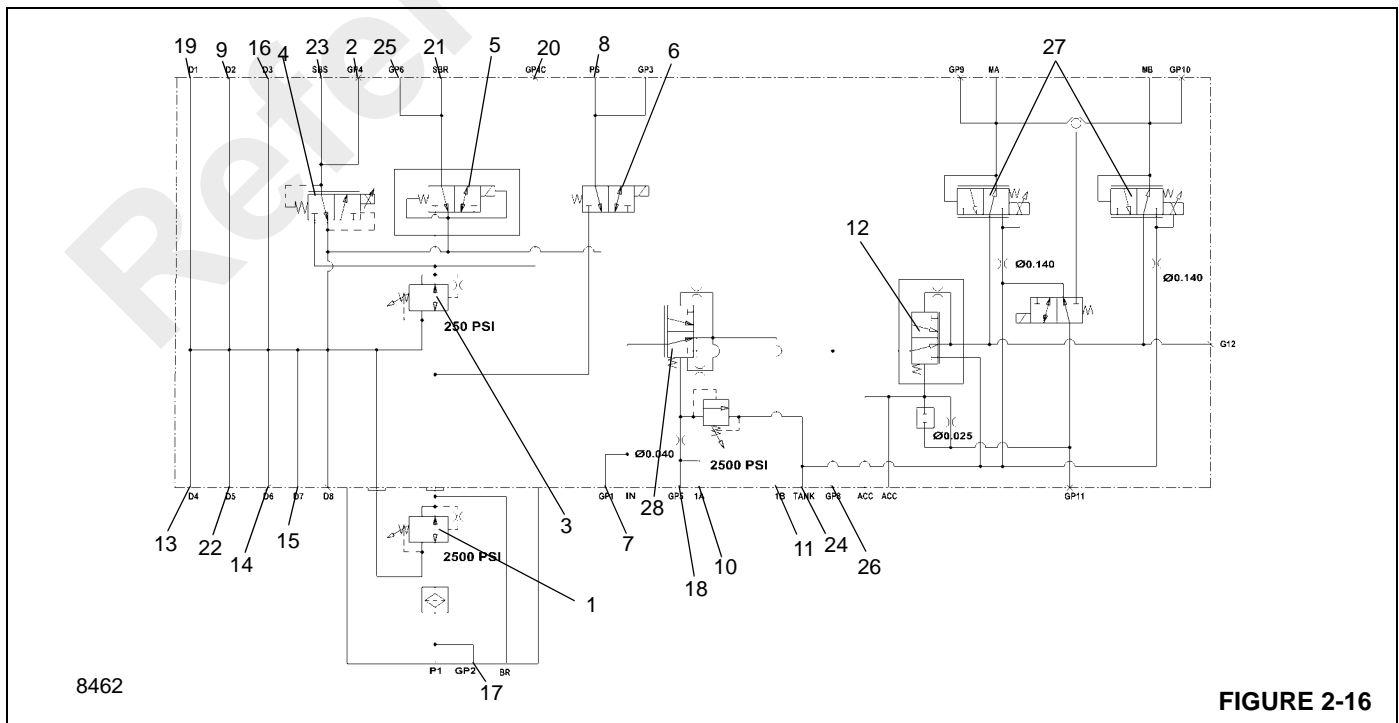
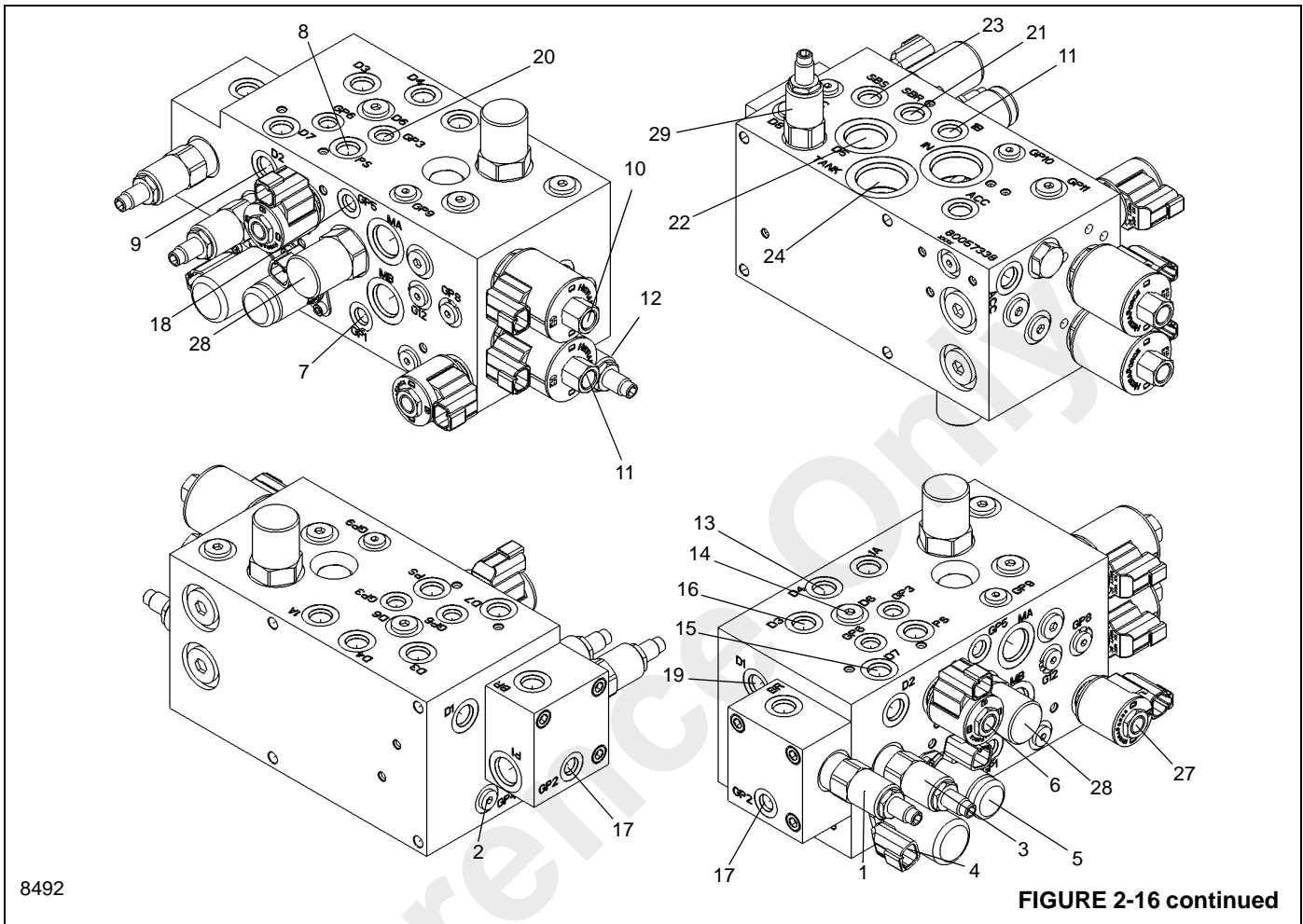

FIGURE 2-16



8492

FIGURE 2-16 continued

1	Pilot Supply Relief Valve	16	Drain Port - D3 (Plugged)
2	Gauge Port- GP4	17	Gauge Port - GP2
3	Swing Brake Relief Valve	18	Gauge Port - GP5
4	Solenoid Valve - Swing Brake	19	Drain Port - D1
5	Solenoid Valve - Swing Brake Release	20	Gauge Port - GP3
6	Solenoid Valve - Pilot Supply	21	Swing Brake Release Port - SBR
7	Gauge Port - GP1	22	Drain Port - D5
8	Pilot Supply Port - PS	23	Swing Brake Supply Port -SBS
9	Drain - D2	24	Tank Port
10	Port 2B - Swing Left	25	Gauge Port - GP6 (Plugged)
11	Port 2A - Swing Right	26	Gauge Port - GP8 (Plugged)
12	Swing Directional Valve	27	Proportional Two Position Two Way Solenoid
13	Drain Port - D4 (Swing Motor Pilot Supply)	28	Steering Priority Valve
14	Drain Port - D6 (Hoist/Tele/Lift valve Pilot Supply)	29	Steer Circuit Load Sense Relief
15	Drain Port - D7 (Swing Brake/Lift Cylinder Pilot)		

STEERING CONTROL VALVE

Description

The steering control unit (Figure 2-17) controls hydraulic flow to the front steering cylinders. It is located on the steering column of the cab.

Both work ports are connected to the rod side of one steer cylinder and to the piston side of the other steer cylinder. A steering wheel input will connect the load sense port #5 to the steering cylinder load demand by way of the steer priority valve located in the swing/steer manifold.

Displacement of the valve is 315 cm³ (19.22 in³).

Maintenance

Removal

1. Tag and disconnect the electrical connector to the valve.
2. Tag and disconnect the hydraulic hoses from the valve. Cap or plug the lines and ports.

3. Remove the capscrews and washers and remove the valve from the steering column.

Installation

1. Secure the valve to the steering column and secure with the capscrews and washers. Torque the capscrews see *Fasteners and Torque Values*, page 1-11.
2. Connect the hydraulic hoses to the ports on the valve as tagged during removal.
3. Connect the electrical connector to the valve as tagged during removal.
4. Verify proper operation of the valve.
5. Check valve and hydraulic connections for leaks. Make repairs as needed.

2

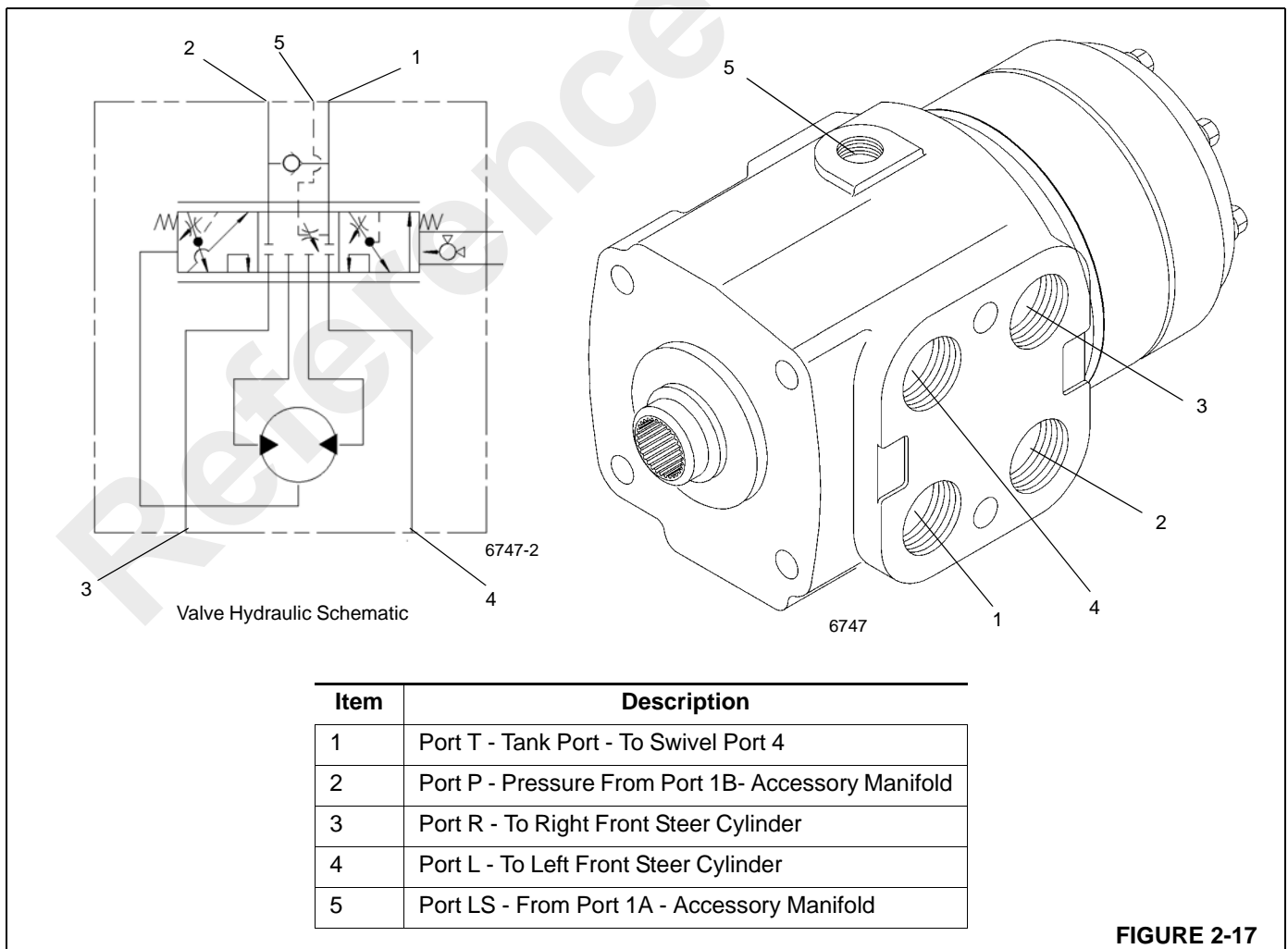

FIGURE 2-17

TANDEM BRAKE VALVE WITH TREADLE PEDAL

Description

The tandem brake valve with treadle pedal (Figure 2-18) is located on the floor of the cab. The tandem brake valve provides split system braking for the primary (front) brakes and the secondary (rear) brakes.

The valve modulates the output pressure 10,342 kPa/103.4 bar (1500 psi) to the brake actuators. The valve is mechanically actuated by a treadle pedal (Figure 2-18). The direct acting spool provides a pedal feel which accurately represents the brake pressure, similar to automotive style pedal feedback as the brake pedal pressure increases, the pedal effort increases proportionally. As the pedal is initially actuated, the tank ports are closed off from the brake ports. With further application of the pedal, the pressure ports are opened to the brake ports until the pedal actuation force and the hydraulic pressure force are balanced.

Also when the pedal is actuated, a pressure switch located off a tee in port F2 provides an electrical signal for brake lights. When the pedal is released, the valve and the pedal return to the non-applied position. In normal operation, the secondary system is piloted from the primary section providing pressure to both systems.

The tandem brake valve consists of a tandem valve body, a closed center spool, a treadle pedal and a mechanical spring assembly to limit the output pressure to the brake actuators to 10,342 kPa/103.4 bar (1500 psi).

Maintenance

Removal

1. Tag and disconnect the electrical connector to the valve.
2. Tag and disconnect the hydraulic hoses from the valve. Cap or plug the lines and ports.
3. Remove the capscrews, lockwashers, flatwashers and nuts securing the valve to the cab Floor. Remove the valve.

Installation

1. Secure the valve to the cab floor with the capscrews, lockwashers, flatwashers and nuts. Torque the capscrews 10 to 11 Nm (7.4 to 8.1 pounds-foot).
2. Connect the hydraulic hoses to the ports on the valve as tagged during removal.
3. Connect the electrical connector to the valve as tagged during removal.
4. Start the engine and check valve and hoses for leaks. Make repairs as needed.

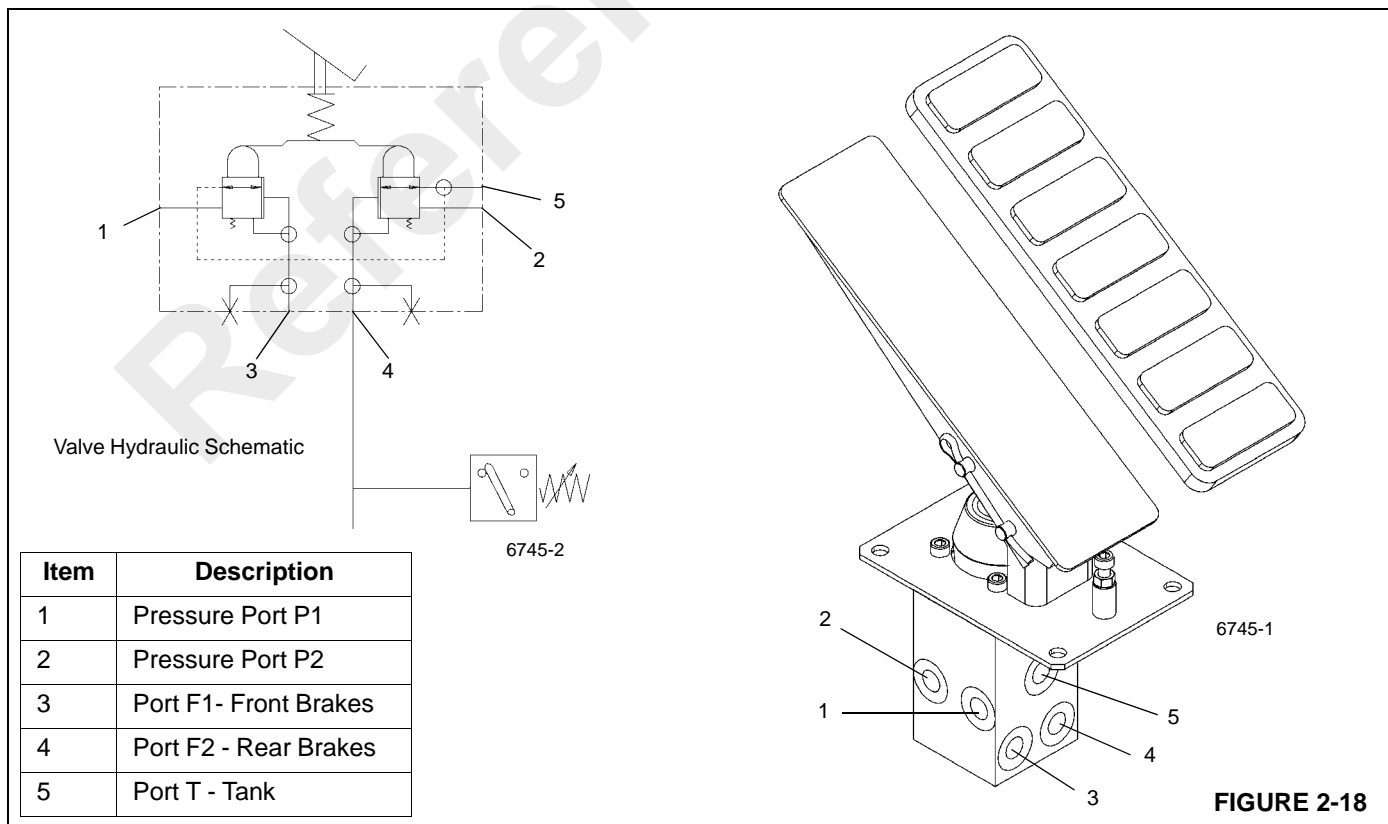

FIGURE 2-18

DUAL ACCUMULATOR CHARGE VALVE

Description

The load sensing dual accumulator charging valve is located on the inside of the left superstructure side plate. The purpose of the valve is to provide pressure regulation to the service brake circuit.

The dual accumulator charge valve consists of an inlet main check valve, a load sense control section with a pilot spool that controls the pump stroke and an inverted shuttle that controls the accumulator charging (Figure 2-19).

When the valve is charging the accumulators, the load sense control section is in neutral position, connecting the load to the pump by way of the load sense line. This brings the piston pump No. 1 on stroke to supply fluid for charging. Fluid passes through the main check valve connecting to the pilot end and through the spool onward to the inverted shuttle that connects the accumulators.

When the control pilot spool bias spring senses the low limit pressure of 13,445 kPa/134 bar (1950 psi), the spool shifts to the neutral position, allowing the pump to charge the accumulators to a maximum of 16,000 kPa/160 bar (2320 psi). The inverted shuttle cartridge senses the pressure in the accumulators to pilot the cartridge closed when maximum charge pressure is reached. Maximum charge

pressure also pilots the control pilot spool to open the load sense line to tank, destroking the piston pump No. 1.

Maintenance

Removal

1. Tag and disconnect the hydraulic hoses from the valve. Cap or plug the lines and ports.
2. Remove the capscrews, flatwashers and lockwashers securing the valve to the turntable. Remove the valve.

Installation

1. Position the valve on the turntable and secure with the capscrews, flatwashers, and lockwashers. Torque capscrews see *Fasteners and Torque Values*, page 1-11
2. Connect the hydraulic hoses to the valve ports as tagged during removal.
3. Start the engine and check for leaks. Make repairs as needed.
4. Depress the brake pedal several times to cause the brake valve to charge. Make several turns with the steering wheel, and swing the superstructure left and right. Verify the brakes, swing and front steering work properly.

Item	Description
1	Port LS - Load Sense Port
2	Port T - Tank Port
3	Port P - Pressure Port
4	Accumulator Port A1
5	Accumulator Port A2
6	Pressure Switch

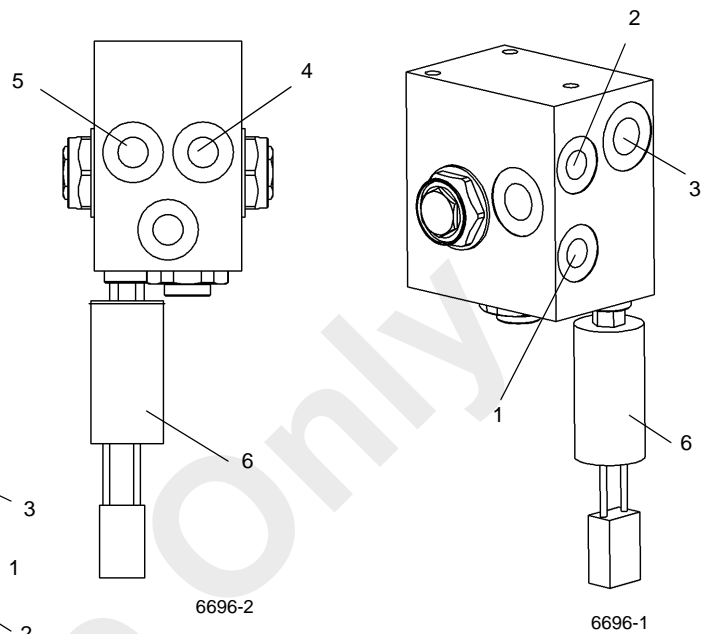
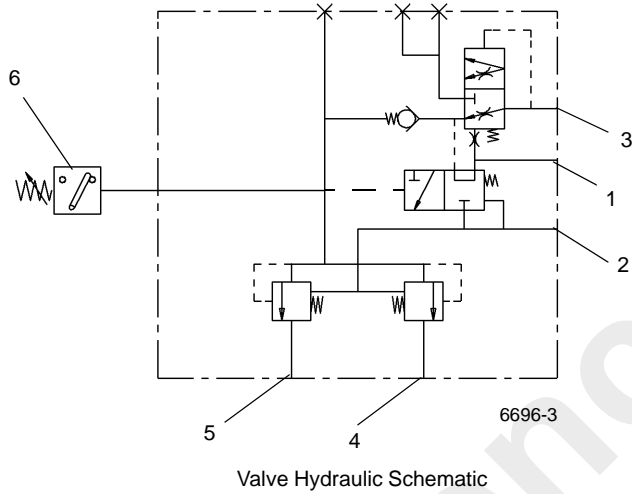

FIGURE 2-19

HYDRAULIC ACCUMULATOR SERVICE BRAKE

Description

The service brake hydraulic accumulators are located on the outside of the left superstructure side plate behind the cab. The purpose of each accumulator is to provide stored energy, an oil volume of 1.23 l (75.1 cu in) at a maximum pressure of 27,579 kPa/275 bar (4000 psi), to actuate the service brake circuits. The dual accumulator charge valve regulates flow to the hydraulic accumulators to provide fully powered independently separate, primary (front) and secondary (rear), service brake circuits.

Each accumulator has two chambers divided by a piston. One side is pre-charged to 5,515.8 kPa/55.1 bar (800 psi) with high purity nitrogen. This maintains a constant pressure in the other chamber which is connected to the modulating brake valve. After the accumulators are fully charged, they will provide the necessary brake system flow and pressure to actuate the brakes.

The accumulator consists of a tube, piston, seals, gas charging valve, and a gas valve guard.

Maintenance

Removal

1. With the engine shutdown, deplete the hydraulic pressure in the accumulators by depressing the service brake pedal several times.
2. Tag and disconnect the hydraulic hose from the accumulator. Cap or plug the line and port.

3. Remove the two nuts securing each clamp half. Remove the each clamp half and accumulator from the turntable.

Installation

1. Position the accumulator in the clamps and secure with the removable clamp halves and nuts.
2. Connect the hydraulic hose to the port on the accumulator as tagged during removal.
3. Pre-charge the accumulator. Refer to paragraph titled Pre-Charging Accumulator in Sub-Section titled Pressure Setting Procedures.
4. Start the engine and check accumulator and hoses for leaks. Make repairs as needed.
5. Depress the brake pedal several times, make several turns with the steering wheel, and swing the superstructure left and right. Verify the brakes, swing, and front steering work properly.

Servicing

The pre-charge nitrogen pressure should be checked every 200 hours or once a month, whichever comes first. Refer to Pressure Setting Procedures in this section.

HOLDING VALVES

Description

A bolt-on manifold style holding valve is installed on the boom lift cylinder. A cartridge style holding valve is used on the telescope cylinder installed in the piston side of the cylinder.

The holding valve provides meter out control, will lock the cylinder in place, prevent a load from running ahead of the oil supply, and will relieve excess pressure caused by thermal expansion.

Maintenance



DANGER

Boom must be fully lowered and fully retracted before removing lift cylinder and telescope cylinder holding valves.

Removal

1. Unscrew holding valve from its port block or manifold.

Installation

1. Check the inside of the port block or manifold for any sharp edges or burrs and remove as necessary with emery cloth.
2. Install new O-rings onto the holding valve.
3. Lubricate the holding valve and O-rings with clean hydraulic oil.

CAUTION

Do not damage the O-rings during installation of the holding valve. If the holding valve turns freely then gets hard to turn, then easy to turn, remove the holding valve and check the O-rings. They have probably been damaged by a sharp edge on one of the ports.

NOTE: The holding valve should turn by hand until compression of the O-rings begins.

4. Carefully install the holding valve into the port block or manifold until fully seated.
5. Test the holding valve and port block or manifold by operating the lift cylinder and/or the telescope cylinder, as applicable. Verify lift cylinder and/or telescope cylinder works without problems; verify there is no leaking. Make repairs as needed.

CROSS AXLE DIFFERENTIAL LOCK VALVE

Description

The optional cross axle differential lock valve is mounted on the right side of the aft center frame cross member. The valve consists of a three way, two position valve without a reducing valve (Figure 2-21). The valve is used to control the application of the crane's hydraulically applied and released cross axle differential lock actuators.

Pressing the top of the cross axle differential lock switch on the front console shifts the three-way, two-position solenoid valve so hydraulic oil can flow to the engage port of the cross axle differential lock actuators, extending them. When the actuators extend, they engage the splines on the differential case and the axle shafts to lock the differential assemblies together.

Releasing the cross axle differential lock switch unlocks the three-way, two-position solenoid valve to apply hydraulic pressure to the spring release of the actuators, retracting them. As the actuators retract, they unlock the axles.

Maintenance

Removal

1. Tag and disconnect the electrical connector from the valve.
2. Tag and disconnect the hydraulic lines attached to the valve. Cap or plug lines and ports.
3. Remove the capscrews, flatwashers, lockwashers and nuts securing the valve to the frame. Remove the valve.

Installation

1. Secure the valve to the frame with the capscrews flatwashers, lockwashers and nuts. Torque the capscrews, see *Fasteners and Torque Values*, page 1-11.
2. Connect the hydraulic lines to the valve as tagged during removal.
3. Connect the electrical connector to the valve as tagged during removal.
4. Apply and release the cross axle differential lock several times. Verify the cross axle differential lock holds the axle from moving when applied so there is no differential action between the wheels.
5. Check for leaks. Make repairs as needed.

Item	Description
1	Three-Way Solenoid Valve
2	Pressure Reducing Valve
3	Port P - From Pressure Port On Transmission
4	Port C - To Differential Lock Actuator On Axles
5	Port T - To Tank Port On Transmission
6	Port G - Gauge Port
7	100 Mesh Screen

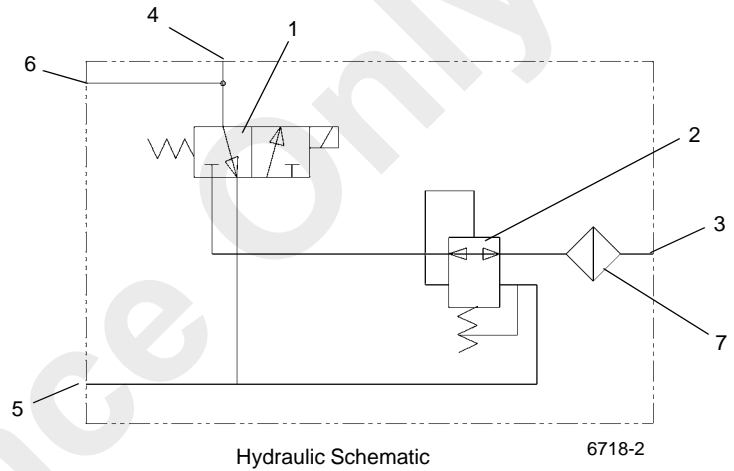

FIGURE 2-20

Item	Description
1	Port 1 to Front and Rear Axle Differential Lock Actuators
2	Port 2 to Park Brake/Shift Valve Port T
3	Port 3 to Park Brake/Shift Valve Port P
4	Solenoid Valve (Connector not shown)

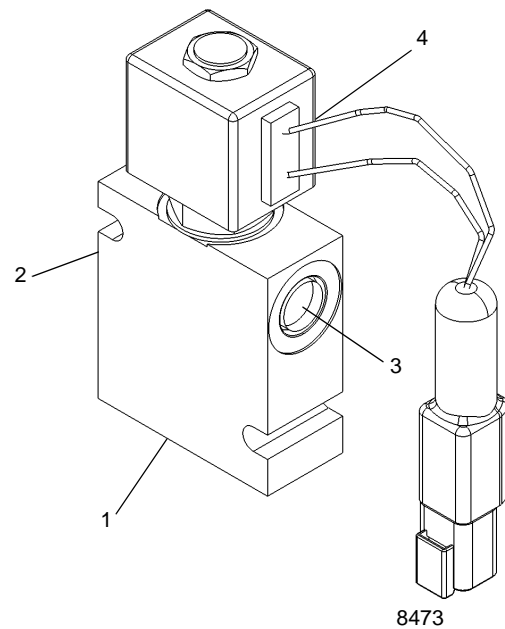
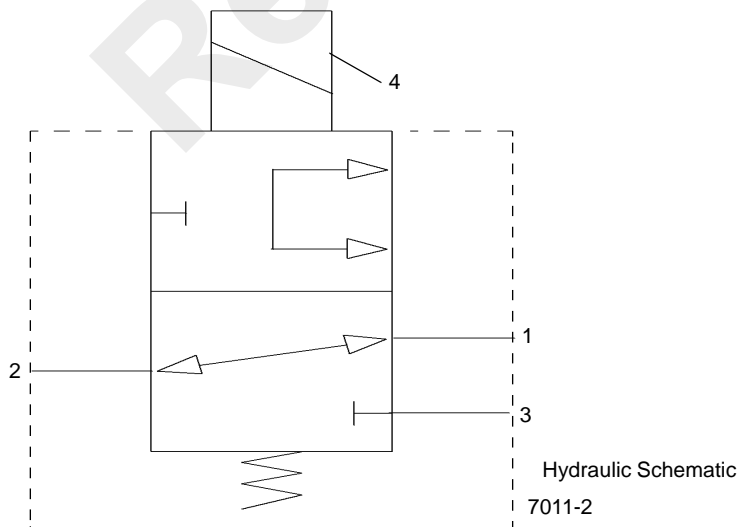

FIGURE 2-21

OUTRIGGER CONTROL MANIFOLD

Description

There are two outrigger control manifolds utilized on the crane, one for the front outriggers and one for the rear outriggers. The manifold consists of four normally closed two position two way solenoid valves (Figure 2-22). They are mounted inside the frame of their respective outrigger box.

When energized, the solenoid shifts the spool to open allowing extension or retraction of the outrigger cylinders.

Maintenance

Removal

1. Tag and disconnect the hydraulic lines to the solenoid valves; cap all lines and openings.
2. Tag and disconnect the electrical connectors.
3. Remove the capscrews, nuts, lockwashers and flatwashers securing the manifold to the outrigger box; remove the manifold.

Inspection

Visually inspect the valves and hydraulic connections for any evidence of leaks or other damage. Check security of the electrical connections. Inspect the wiring for any evidence of cracks or breaks.

Installation

1. Position the manifold on the mounting and secure with the lockwashers, flatwashers, nuts and capscrews. Torque capscrews see *Fasteners and Torque Values*, page 1-11.
2. Connect the electrical connectors to the solenoids as marked during removal.
3. Connect the hydraulic lines to the valves as marked during removal.

Functional Check

Activate the hydraulic system and cycle the affected cylinder(s) several times. Observe for proper functioning of the affected cylinder(s). Ensure the solenoid valve hydraulic connections are secure.

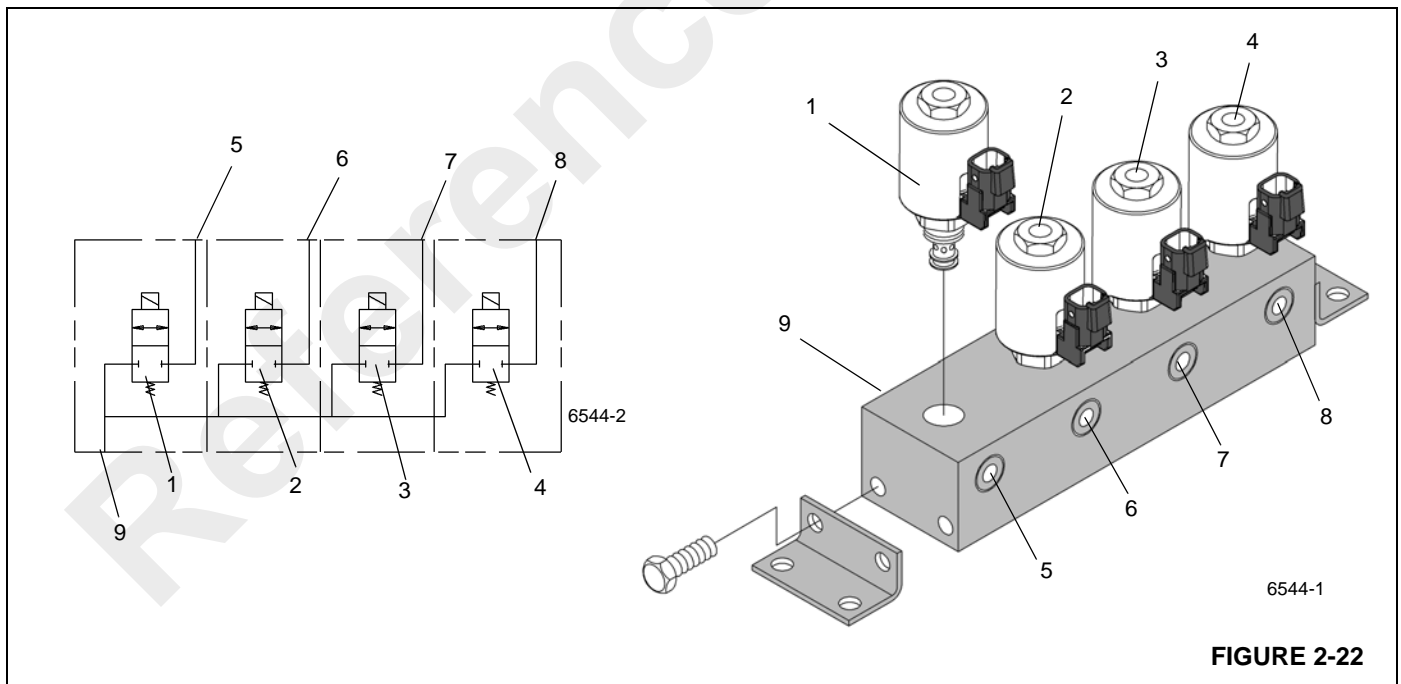

FIGURE 2-22

1	Solenoid Valve - Left Front or Rear Extension Cyl	6	Outlet Port Left Front or Rear Jack Cylinder
2	Solenoid Valve - Left Front or Rear Jack Cylinder	7	Outlet Port Right Front or Rear Jack Cylinder
3	Solenoid Valve Right Front or Rear Jack Cylinder	8	Outlet Port Right Front or Rear Extension Cyl
4	Solenoid Valve Right Front or Rear Extension Cyl	9	In Port (Far Side) - From Port B of Outrigger Selector Valve
5	Outlet Port - Left Front or Rear Extension Cyl		

PILOT OPERATED CHECK VALVE

Description

A pilot operated (PO) check valve is located in each outrigger jack cylinder port block. The check valve functions as a holding valve for the jack cylinder. Oil flow is directed from the “V” port to the “C” ports, while blocking flow in the opposite direction. Flow is reversed from “C” to “V” when pressure pilot oil is applied to the opposite side “V” port (Figure 2-23)

Maintenance

Removal

1. Unscrew the check valve from the jack cylinder port block.

Installation

1. Check the inside of the port block for any sharp edges or burrs and remove as necessary with emery cloth.
2. Install new O-rings onto the check valve.

3. Lubricate the check valve and O-rings with clean hydraulic oil.

CAUTION

Do not damage the O-rings during installation of the check valve. If the check valve turns freely then gets hard to turn, then easy to turn, remove the check valve and check the O-rings. They have probably been damaged by a sharp edge of a port.

NOTE: The check valve should turn by hand until compression of the O-rings begins.

4. Carefully install the check valve into the port block until fully seated.
5. Test the check valve and port block by operating the affected outrigger’s jack cylinder. Verify it extends and retracts without problems; verify there is no leaking. Make repairs as needed.

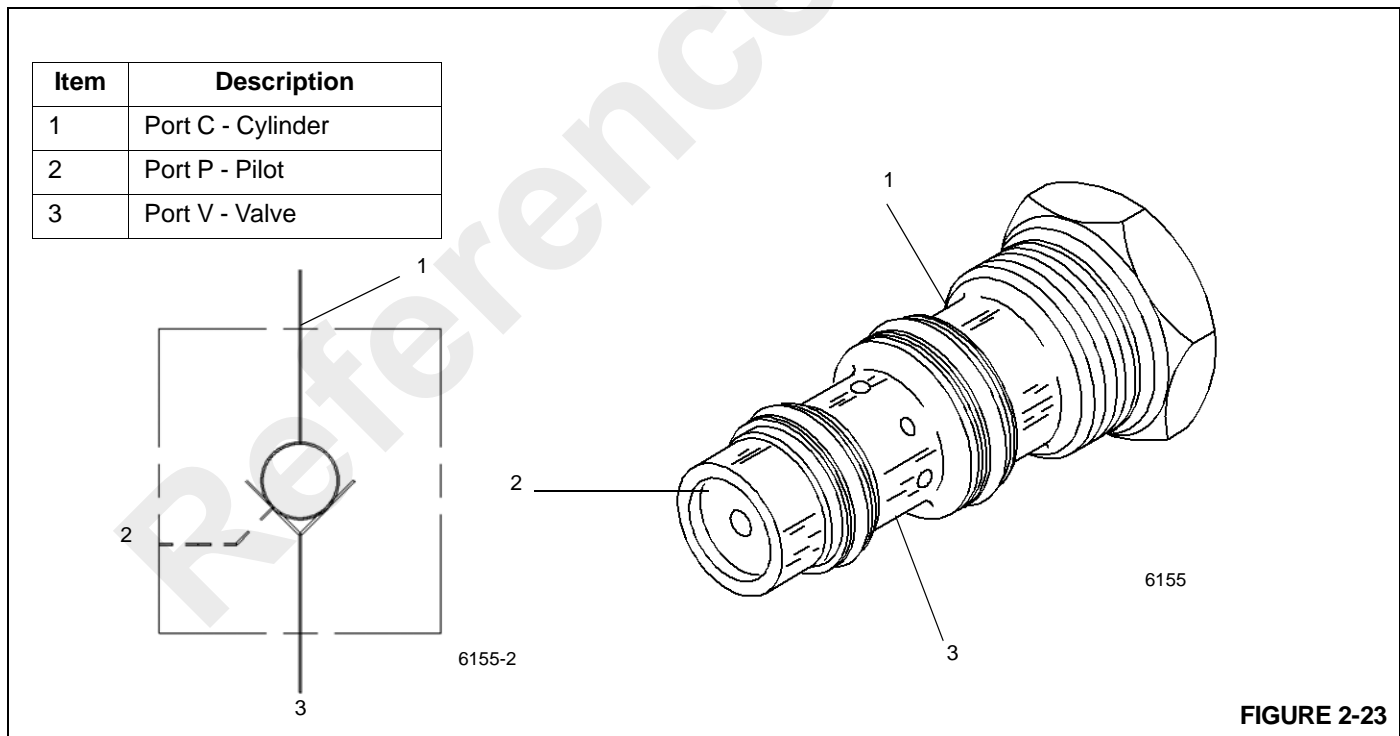

FIGURE 2-23

INTEGRATED OUTRIGGER/REAR STEER MANIFOLD

Description

The integrated outrigger/rear steer manifold (Figure 2-24) controls the outrigger and rear steer circuit. The valve is mounted on the frame center section to the rear of the front axle.

The manifold is made up of two sections; an inlet section and a working section.

The inlet section contains a 17,200 kPa/172 bar (2500 psi) pressure reducing valve and a load sense shuttle valve. The solenoid valve is a normally closed two position two way valve. It unloads the load sense line to the pump to ensure the pump is de-stroked during engine start.

The rear steer section contains a three position four way solenoid controlled directional valve that controls left and right rear steer. The rear steer cylinders are positive locked by the double pilot operated check valves integral to the work ports.

The outrigger section contains a three position four way pilot controlled directional valve, two check valves, two load sense shuttle valves, and two, two position three way solenoids for pilot control of the outrigger extend and retract function.

Maintenance

Removal

1. Tag and disconnect the electrical connectors to the valve.
2. Tag and disconnect the hydraulic hoses from the valve. Cap or plug the lines and ports.
3. Remove the capscrews and washers securing the valve to the frame bracket. Remove the valve.

Installation

1. Secure the valve to the frame bracket with the washers and capscrews. Torque the capscrews see *Fasteners and Torque Values*, page 1-11.
2. Connect the hydraulic hoses to the ports on the valve as tagged during removal.
3. Connect the electrical connectors to the valve as tagged during removal.
4. Verify operation as follows:
 - Operate the rear steer left and right to verify smooth operation.
 - On outriggers, swing over the front outriggers to ensure the oscillation cylinders lockout.
 - Remove the electrical connection from the oil cooler motor two position three-way solenoid valve to verify that it operation.
5. Check valve and hoses for leaks. Make repairs as needed.

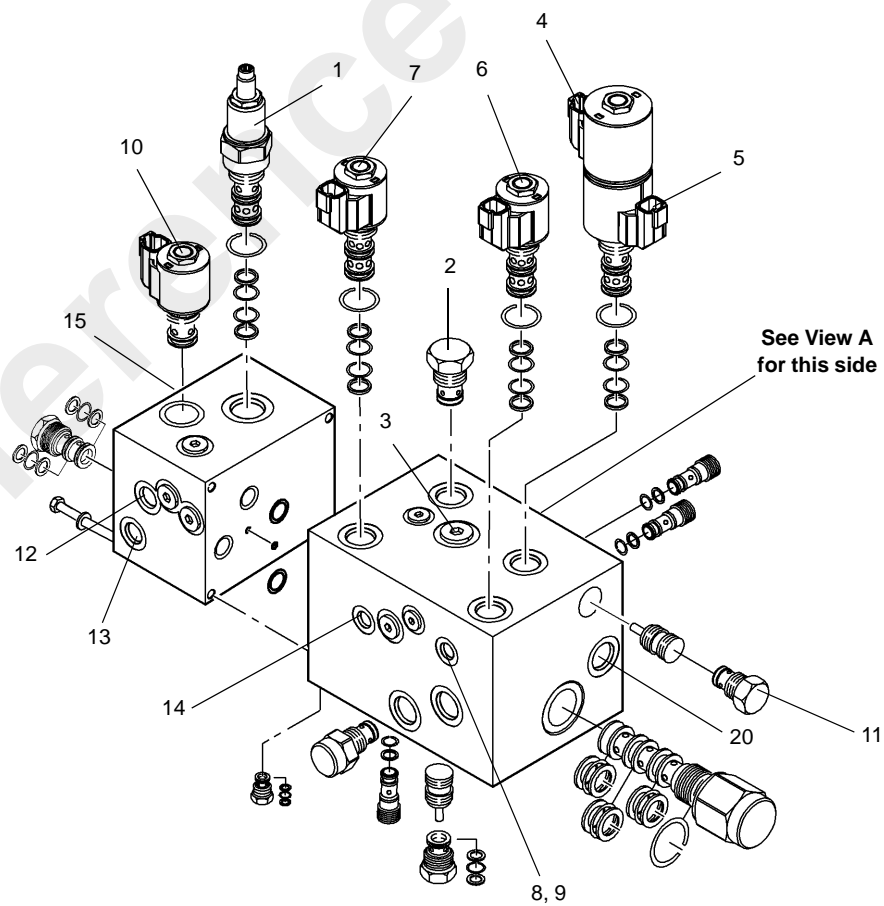
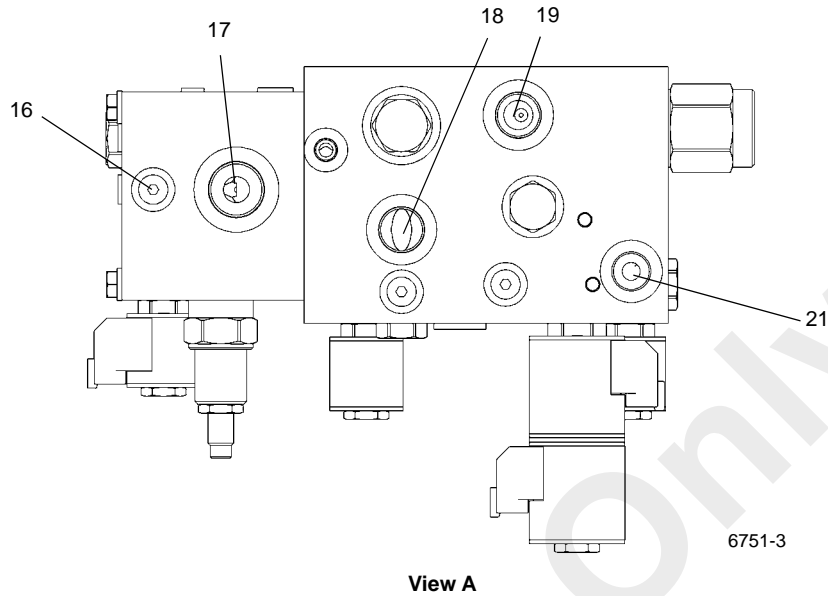
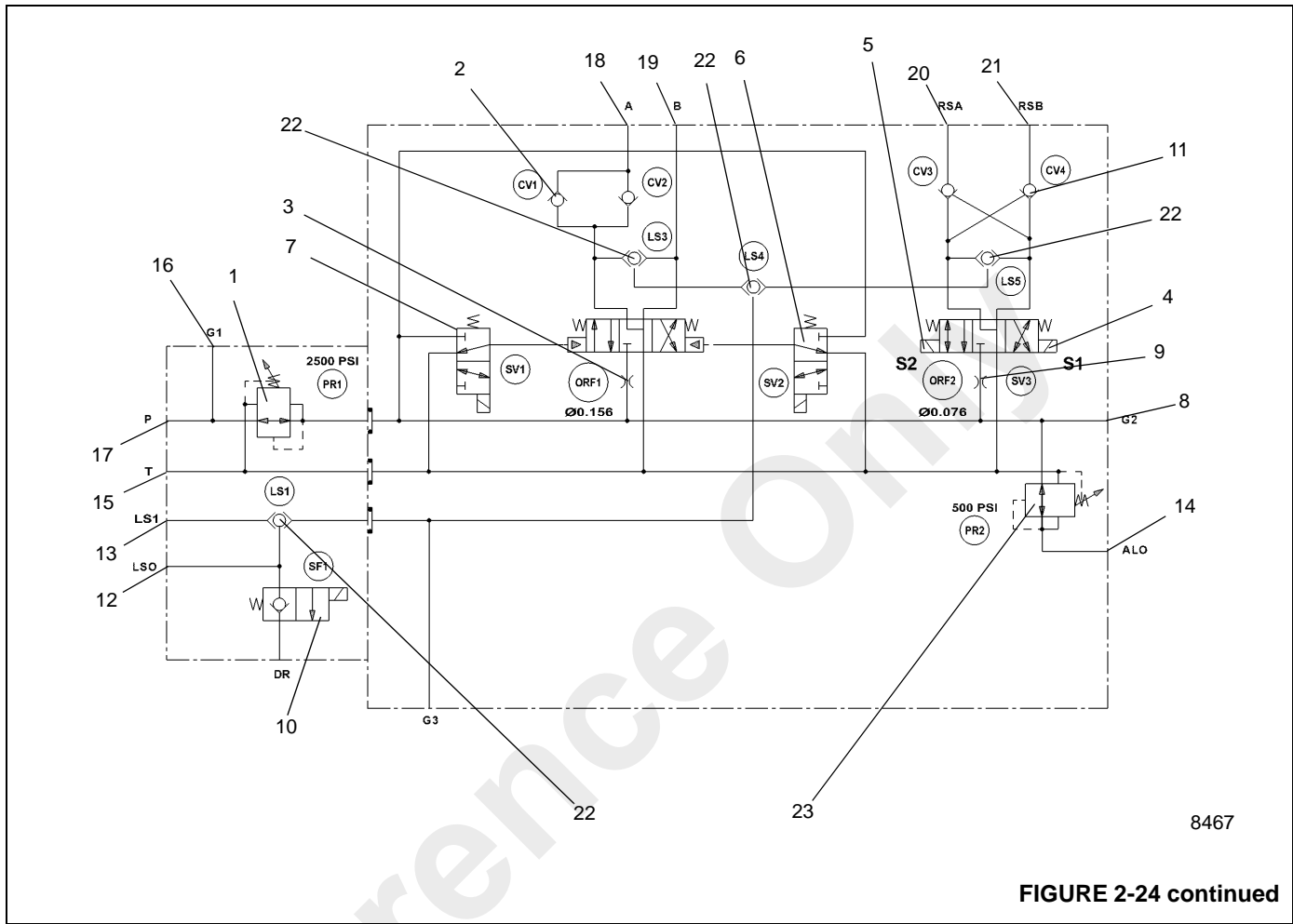

FIGURE 2-24



8467

FIGURE 2-24 continued

1	Pressure Reducing Valve - PR1	13	Load Sense - LS1
2	Check Valve - CV1	14	Port ALO - To Axle Lockout Valve
3	Orifice - ORF1	15	Port T - Tank
4	Solenoid Valve - Rear Steer S1	16	Port G1 - Gauge Port
5	Solenoid Valve - Rear Steer S2	17	Port P - Pressure From Pump #1
6	Solenoid Valve - SV2	18	Port A - Outrigger Retract
7	Solenoid Valve - SV1	19	Port B - Outrigger Extend
8	Gauge Port - G2	20	Port RSA - Left Rear Steer
9	Orifice - ORF2	21	Port RSB - Right Rear Steer
10	Solenoid - SF1	22	Load Sense Shuttle Valve
11	Check Valve - CV4	23	Pressure Reducing Valve - PR2
12	Load Sense - LS0		

CHECK VALVES

Description

Check valves are used in the crane hydraulic system to block flow in one direction and allow free flow in the opposite direction.

A check valve is plumbed in-line at the inlet of the front steer control valve. It prevents steering wheel kick-back if the steer cylinder pressure rises above the inlet port pressure.

Maintenance

Removal

1. Tag and disconnect hydraulic lines from the valve and cap or plug all openings and remove valve.

Installation

1. Connect the hydraulic lines as tagged during removal.
2. Check valve and hydraulic connections for leaks. Make repairs as needed.

Reference Only

RANGE SHIFT/PARKING BRAKE VALVE

Description

The range shift/parking brake valve controls the flow of oil to the parking brake, hi-low range and axle disconnect actuators by the use of two solenoid valves (Figure 2-25). The valve is located on the center of the frame. Pressure is supplied to the valve from the transmission charge pump.

The parking brake solenoid valve is a two position three-way valve. In its de-energized position, the inlet port is blocked and the parking brake actuator is drained to the reservoir. When the solenoid is energized, the reservoir port is blocked and pressurized oil is directed to the actuator, releasing the parking brake.

The range shift solenoid valve is a two position four-way valve. In its de-energized position, pressurized oil flows to the "B" port of the range shift actuator, while the "A" port is drained to the reservoir along with the axle disconnect actuator for two wheel drive/high range. When the solenoid is energized, pressurized oil is directed to the "A" port of the range shift actuator hydraulic spring release while port "B" of the range shift actuator is drained to the reservoir for four wheel drive/low range.

Maintenance

Removal

1. Tag and disconnect the electrical connectors to the valve.
2. Tag and disconnect the hydraulic hoses from the valve. Cap or plug the lines and ports.
3. Remove the capscrews, lockwashers, flatwashers and nuts securing the valve to the frame. Remove the valve.

Installation

1. Secure the valve to the frame with the nuts, flatwashers, lockwashers and capscrews. Torque the capscrews, see *Fasteners and Torque Values*, page 1-11.
2. Connect the hydraulic hoses to the ports on the valve as tagged during removal.
3. Connect the electrical connectors to the valve as tagged during removal.

Functional Tests

1. Start and idle engine.
2. With units on outriggers, check for proper two/four wheel operation.

Item	Description
1	Port P - Pressure
2	Port T - Tank
3	Port A - Range Shift Actuator
4	Port B - Range Shift Actuator
5	Port PB - To Park Brake
6	Solenoid Valve - Range Shift
7	Solenoid Valve - Park Brake
8	Pressure Switch

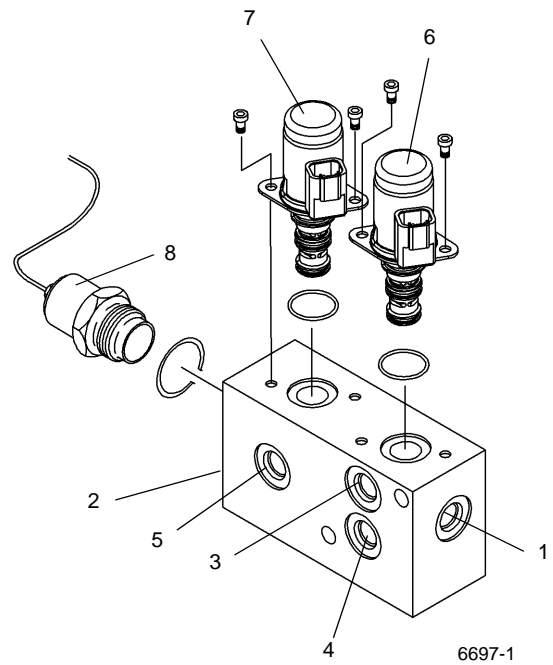
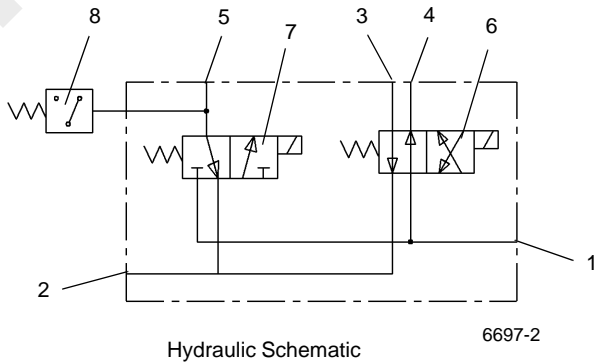

FIGURE 2-25

AXLE OSCILLATION LOCKOUT VALVE (STANDARD UNITS)

Description

The axle oscillation lockout valve is used in the rear axle oscillation lockout circuit. The valve is located on the left inner center frame rail. It consists of a valve body and two normally-closed, two way, two position solenoid valves. It keeps the lockout cylinders from oscillating, unless the turntable is centered forward.

The area definition potentiometer in the electrical swivel energizes and deenergizes the axle oscillation relay. When the superstructure is more than 6 degrees left or right of directly over the front, the axle oscillation relay is deenergized.

When the axle oscillation lockout valve is open, the normally closed solenoid valves are deenergized and isolate the lockout cylinders from hydraulic oil supply. This keeps the cylinders from oscillating (moving up and down) because hydraulic oil cannot leave the cylinders. Instead, the cylinders remain full of hydraulic oil and rigid.

When the axle oscillation lockout valve is closed, the solenoid valves are energized and open. This allows hydraulic oil in and out of the cylinders, allowing them to oscillate.

Maintenance

Removal

1. Tag and disconnect the electrical connectors to the valve.
2. Tag and disconnect the hydraulic hoses from the valve. Cap or plug the lines and ports.
3. Remove the capscrews, hex nuts, flatwashers and lockwashers securing the valve to the frame. Remove the valve.

Installation

1. Secure the valve to the crane with the capscrews, hex nuts, flatwashers and lockwashers. Torque the capscrews, see *Fasteners and Torque Values*, page 1-11.
2. Connect the hydraulic hoses to the ports on the valve as tagged during removal.
3. Connect the electrical connectors to the valve as tagged during removal.
4. Check valve and hoses for leaks. Make repairs as needed.

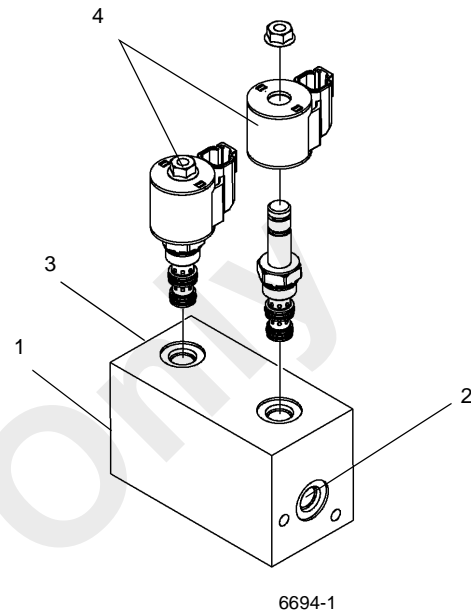
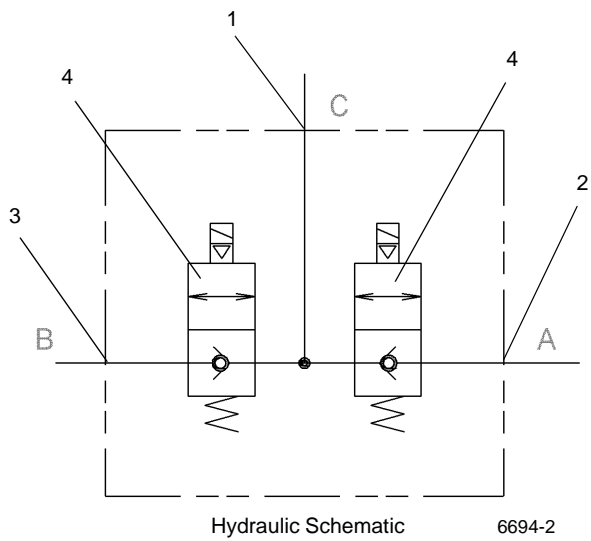

FIGURE 2-26

1	Port C- Pressure From Axle Lockout Port On Outrigger Selector Valve	3	Port B - To Left Hand Lockout Cylinder
2	Port A - To Right Hand Lockout Cylinder	4	Solenoid Valve

AXLE OSCILLATION LOCKOUT VALVE (OPTIONAL CE UNITS)

Description

The axle oscillation lockout valve is used in the rear axle oscillation lockout circuit. The valve is located on the left inner center frame rail. It consists of a valve body, a normally-closed three-way, two position solenoid valve and a pressure reducing valve. It keeps the lockout cylinders from oscillating unless the turntable is centered forward.

The area definition potentiometer in the electrical swivel energizes and deenergizes the axle oscillation relay. When the superstructure is more than 6 degrees left or right of directly over the front, the axle oscillation relay is deenergized.

When the axle oscillation lockout valve is open, the normally closed solenoid valves are deenergized and isolate the lockout cylinders from hydraulic oil supply. This keeps the cylinders from oscillating (moving up and down) because hydraulic oil cannot leave the cylinders. Instead, the cylinders remain full of hydraulic oil and rigid.

When the axle oscillation lockout valve is closed, the solenoid valves are energized and open. This allows hydraulic oil in and out of the cylinders, allowing them to oscillate.

Maintenance

Removal

1. Tag and disconnect the electrical connectors to the valve.
2. Tag and disconnect the hydraulic hoses from the valve. Cap or plug the lines and ports.
3. Remove the capscrews, hex nuts, flatwashers and lockwashers securing the valve to the frame. Remove the valve.

Installation

1. Secure the valve to the crane with the capscrews, hex nuts, flatwashers and lockwashers. Torque the capscrews, see *Fasteners and Torque Values*, page 1-11.
2. Connect the hydraulic hoses to the ports on the valve as tagged during removal.
3. Connect the electrical connectors to the valve as tagged during removal.
4. Check valve and hoses for leaks. Make repairs as needed.

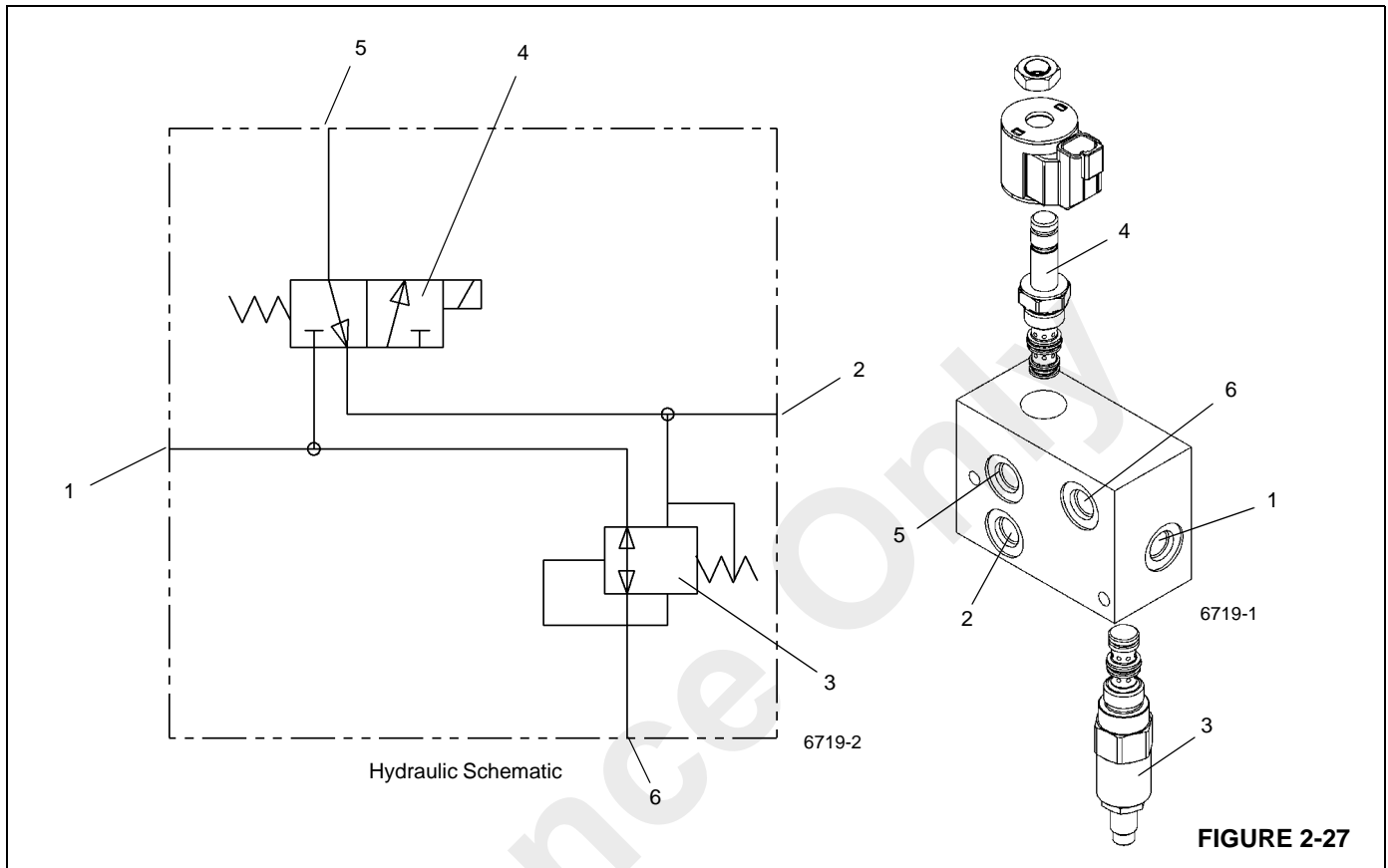

FIGURE 2-27

Item	Description
1	Port P - Pressure From Axle Lockout Port On Outrigger Selector Valve
2	Port T - Tank
3	Pressure Reducing Valve

Item	Description
4	Solenoid Valve
5	Port B - To Lockout Cylinder Pilot
7	Port P1 - To Lockout Cylinder

CYLINDERS

General

This subsection provides descriptive information for all the hydraulic cylinders used on this crane. The description of the cylinder given here is for the cylinder itself. For information on how the cylinder functions in the individual circuits, refer to the Description and Operation of that circuit.

**Table 2-3
Wear Ring Gap**

Head (or Piston) Size		Wear Ring Gap	
Inch	mm	Inch	mm
1 to 4.75	25.4 to 120.7	0.125	3.18
5 to 10.0	127.0 to 254.0	0.187	4.75
greater than 10.0	greater than 254.0	0.250	6.35

Surface Protection for Cylinder Rods

Steel cylinder rods include a thin layer of chrome plating on their surfaces to protect them from corroding. However, chrome plating inherently has cracks in its structure which can allow moisture to corrode the underlying steel. At typical ambient temperatures, hydraulic oil is too thick to penetrate these cracks. Normal machine operating temperatures will allow hydraulic oil to warm sufficiently to penetrate these cracks and if machines are operated daily, protect the rods. Machines that are stored, transported, or used in a corrosive environment (high moisture, rain, snow, or coastline conditions) need to have the exposed rods protected more frequently by applying a protectant. Unless the machine is operated daily, exposed rod surfaces will corrode. Some cylinders will have rods exposed even when completely retracted. Assume all cylinders have exposed rods, as corrosion on the end of the rod can ruin the cylinder.

It is recommended that all exposed cylinder rods be protected using Boeshield® T-9 Premium Metal Protectant. Manitowoc Crane Care has Boeshield® T-9 Premium Metal Protectant available in 12 oz. cans that can be ordered through the Parts Department.

NOTE: Cylinder operation and inclement weather will remove the Boeshield® protectant; therefore, inspect machines once a week and reapply Boeshield® to unprotected rods.

Maintenance

General

There must be a gap between the ends of each wear ring when it is installed onto the piston (as applicable) or head. In addition, each wear ring gap is to be located as follows: Divide 360 degrees by the number of wear rings on the component. The resulting value is the number of degrees each wear ring gap is to be located with respect to each other.

The approximate wear ring gaps are as follows:

Leakage Check

A hydraulic cylinder should not be disassembled unless it is essential. The following checks will provide a means of determining if a cylinder has a faulty or leaking piston seal.

1. Extend the rod to its maximum stroke. Remove the retract hose from the cylinder. Cap the retract hose.



DANGER

Ensure pressure is applied to the piston side of the cylinder only and the retract hose is capped.

2. Apply hydraulic pressure to the piston side of the cylinder and observe the open cylinder port for leakage. If leakage is observed, the seals in the cylinder must be replaced.
3. Fully retract the cylinder rod (except the telescope cylinder). Remove the extend hose from the cylinder. Cap the extend hose.



DANGER

Ensure pressure is applied to the retract (rod) side of the cylinder only and that the extend hose is capped.

4. Apply hydraulic pressure to the retract (rod) side of the cylinder and observe the open cylinder port for leakage.

If leakage is observed, the seals in the cylinder must be replaced.

5. Reconnect all cylinder ports.

Temperature Effects on Hydraulic Cylinders

Hydraulic oil expands when heated and contracts when cooled. This is a natural phenomena that happens to all liquids. The coefficient of expansion for API Group 1 hydraulic oil is approximately 0.00043 cubic inches per cubic inch of volume for 1°F of temperature change. **Thermal contraction will allow a cylinder to retract as the hydraulic fluid which is trapped in the cylinder cools.** The change in the length of a cylinder is proportional to the extended length of the cylinder and to the change in temperature of the oil in the cylinder. For example, a cylinder extended 25 feet in which the oil cools 60°F would retract approximately 7 3/4 inches (see chart below). A cylinder extended 5 feet in which the oil cools 60°F would only retract approximately 1 1/2 inches. The rate at which the oil cools depends on many factors and will be more noticeable with a larger difference in oil temperature verses the ambient temperature.

Thermal contraction coupled with improper lubrication or improper wear pad adjustments may, under certain conditions, cause a “stick-slip” condition in the boom. This “stick-slip” condition could result in the load not moving smoothly. Proper boom lubrication and wear pad adjustment is important to permit the boom sections to slide freely. Slow movement of the boom may be undetected by the operator, unless a load is suspended for a long period of time. To

minimize the effects of thermal contraction or “Stick-slip” it is recommended that the telescope control lever is activated periodically in the extend position to mitigate the effects of cooling oil.

If a load and the boom is allowed to remain stationary for a period of time and the ambient temperature is cooler than the trapped oil temperature, the trapped oil in the cylinders will cool. The load will lower as the telescope cylinder(s) retracts allowing the boom to come in. Also, the boom angle will decrease as the lift cylinder(s) retracts causing an increase in radius and a decrease in load height.

This situation will also occur in reverse. If a crane is set up in the morning with cool oil and the daytime ambient temperature heats the oil, the cylinders will extend in similar proportions.

The charts below have been prepared to assist you in determining the approximate amount of retraction/extension that may be expected from a hydraulic cylinder as a result of change in the temperature of the hydraulic oil inside the cylinder. The chart is for dry rod cylinders. If the cylinder rod is filled with hydraulic oil, the contraction rate is somewhat greater.

NOTE: Operators and service personnel must be aware that load movement, as a result of this phenomena, can be easily mistaken as leaking cylinder seals or faulty holding valves. If leaking seals or faulty holding valves are suspected to be the problem, refer to Service Bulletin 98-036 dealing with testing telescope cylinders.

Table 2-4 Boom Drift Chart (Cylinder length change in inches)

Coeff. = 0.00043 (in ³ /in ³ /°F)										
STROKE (FT.)	Temperature Change (°F)									
	10	20	30	40	50	60	70	80	90	100
5	0.26	0.52	0.77	1.03	1.29	1.55	1.81	2.06	2.32	2.58
10	0.52	1.03	1.55	2.06	2.58	3.10	3.61	4.13	4.64	5.16
15	0.77	1.55	2.32	3.10	3.87	4.64	5.42	6.19	6.97	7.74
20	1.03	2.06	3.10	4.13	5.16	6.19	7.22	8.26	9.29	10.32
25	1.29	2.58	3.87	5.16	6.45	7.74	9.03	10.32	11.61	12.90
30	1.55	3.10	4.64	6.19	7.74	9.29	10.84	12.38	13.93	15.48
35	1.81	3.61	5.42	7.22	9.03	10.84	12.64	14.45	16.25	18.06
40	2.06	4.13	6.19	8.26	10.32	12.38	14.45	16.51	18.58	20.64
45	2.32	4.64	6.97	9.29	11.61	13.93	16.25	18.58	20.90	23.22
50	2.58	5.16	7.74	10.32	12.90	15.48	18.06	20.64	23.22	25.80
55	2.84	5.68	8.51	11.35	14.19	17.03	19.87	22.70	25.54	28.38
60	3.10	6.19	9.29	12.38	15.48	18.58	21.67	24.77	27.86	30.96

Length change in inches = Stroke (Ft.) X Temperature Change (°F) X Coeff. (in³/in³/ °F) X 12 in/ft

Table 2-5 Boom Drift Chart (Cylinder length change in millimeters)

Coeff. = 0.000774 (1/°C)											
STROKE (m)	Temperature Change (°C)										
	5	10	15	20	25	30	35	40	45	50	55
1.5	5.81	11.61	17.42	23.22	29.03	34.83	40.64	46.44	52.25	58.05	63.86
3	11.61	23.22	34.83	46.44	58.05	69.66	81.27	92.88	104.49	116.10	127.71
4.5	17.42	34.83	52.25	69.66	87.08	104.49	121.91	139.32	156.74	174.15	191.57
6	23.22	46.44	69.66	92.88	116.10	139.32	162.54	185.76	208.98	232.20	255.42
7.5	29.03	58.05	87.08	116.10	145.13	174.15	203.18	232.20	261.23	290.25	319.28
9	34.83	69.66	104.49	139.32	174.15	208.98	243.81	278.64	313.47	348.30	383.13
10.5	40.64	81.27	121.91	162.54	203.18	243.81	284.45	325.08	365.72	406.35	446.99
12	46.44	92.88	139.32	185.76	232.20	278.64	325.08	371.52	417.96	464.40	510.84
13.5	52.25	104.49	156.74	208.98	261.23	313.47	365.72	417.96	470.21	522.45	574.70
15	58.05	116.10	174.15	232.20	290.25	348.30	406.35	464.40	522.45	580.50	638.55
16.5	63.86	127.71	191.57	255.42	319.28	383.13	446.99	510.84	574.70	638.55	702.41
18	69.66	139.32	208.98	278.64	348.30	417.96	487.62	557.28	626.94	696.60	766.26

Length change in mm = Stroke (m) X Temperature Change (°C) X Coeff. (1/ °C) X 1000 mm/m

LIFT CYLINDER

Description

The lift cylinder (Figure 2-28) has a bore of 22.8 cm (9.0 inches). The retracted length of the cylinder from the center of the barrel bushing to the center of the rod bushing is 265.1cm (104.4 inches). The extended length of the cylinder from the center of the barrel bushing to the center of the rod bushing is 464.5 cm (182.9 inches). Its stroke is 199.3 cm (78.5 inches). A wiper ring prevents foreign material from entering the cylinder. O-rings and other seals prevent internal and external leakage.

The cylinder weighs approximately 521 kg (1149 lb).

Maintenance

Disassembly

NOTE: Any maintenance requiring disassembly of the cylinders should include replacement of all seals and rings. A seal kit will supply the required items.

1. Disconnect the tube assembly from the holding valve.
2. Remove the capscrews and washers securing the holding valve and remove the holding valve from the cylinder barrel.
3. Break the tack weld and remove the pin and retaining plate.
4. Using a spanner wrench or chain wrench, unscrew the head from the barrel.



DANGER

Do not use air pressure to remove the rod. Use only a source of controlled hydraulic oil pressure if the rod is hard to move.

CAUTION

Exercise extreme care when handling or setting down the rod. Damage to the rod surface may cause unnecessary maintenance and expense.

5. Remove the rod and attached parts from the barrel.

NOTE: Cover the barrel opening to avoid contamination.

CAUTION

When removing seals and rings, avoid scratching the grooved and gland surfaces.

6. Remove the two hydrolock seals and guidelock ring from the outside of the piston.

NOTE: Arranging discarded seals and rings in the order of disassembly will aid in installation of new seals and rings. Pay attention to how each seal and ring is installed to avoid installing replacement seals and rings improperly.

7. Remove the set screw securing the piston to the rod.
8. Unscrew the piston from the rod.
9. Remove the O-ring and two backup rings from the inside of the piston.
10. Remove the head from the rod.
11. Remove the O-ring and the backup ring from the outside of the head and the wear ring, buffer seal, deep Z rod seal, and wiper ring from the inside of the head.

Inspection

1. Clean all parts with solvent and dry with compressed air. Inspect all parts for serviceability.
2. Inspect the barrel carefully for scoring. If barrel is scored, it must be repaired or replaced.
3. Check piston for damage. If piston is damaged, determine if it can be repaired or must be replaced.
4. Inspect rod for straightness. Determine if it can be straightened or must be replaced.

CAUTION

Before installing new seals and rings, clean all surfaces and carefully remove burrs and nicks. Parts displaying excessive wear or damage should be replaced.

5. Stone out minor blemishes and polish with a fine crocus cloth.
6. Clean with solvent and dry with compressed air any parts that have been stoned and polished.

Assembly

CAUTION

When installing new seals and rings, avoid stretching seals or scratching the grooved or gland surfaces. Make sure parts are clean before and during assembly. Make sure seals and rings are installed in the proper order.

NOTE: Lubricate seals and rings with clean hydraulic oil.

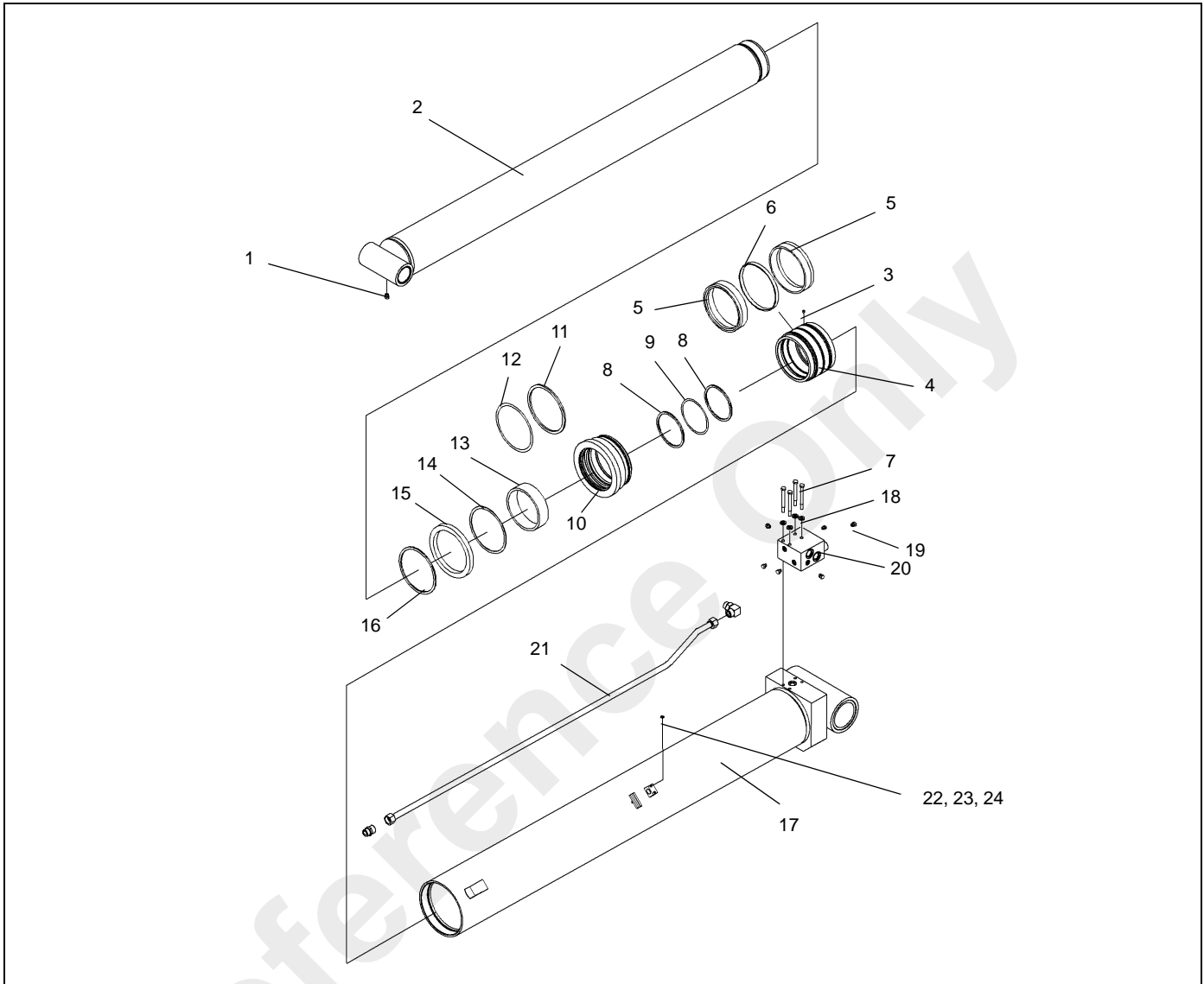

Item	Description
1	Grease Fitting
2	Rod
3	Setscrew
4	Piston
5	Seal Assembly
6	Guidelock Ring
7	Capscrew
8	Backup Ring
9	O-ring
10	Head
11	Backup Ring
12	O-ring

Item	Description
13	Wear Ring
14	Buffer Seal
15	Rod Seal
16	Wiper Ring
17	Barrel
18	Washer
19	Plug
20	Holding Valve
21	Tube Assembly
22	Nut
23	Capscrew
24	Pipe Clamp

1. Install the replacement wear ring, buffer seal, rod seal, backup ring and wiper ring in the inside of the head. Make sure the buffer seal's step is closer to the rod seal. Make sure the rod seal's rim groove is closer to the buffer seal (Figure 2-29).

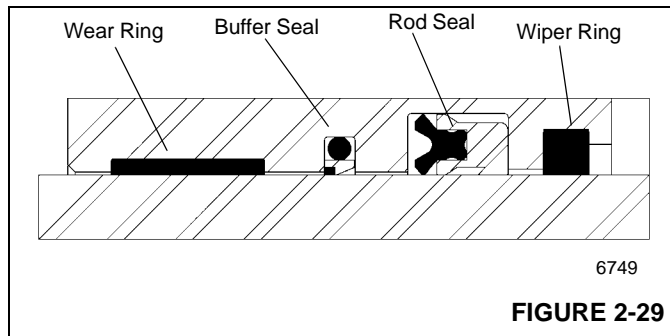

2. Install the replacement O-ring and the backup ring on the outside of the head.
3. Install the replacement O-ring and backup rings in the inside of the piston.
4. Lubricate the rod with clean hydraulic oil.
5. Slide the head, wiper ring end first, onto the rod.
6. Screw the piston onto the rod tightly. Secure the piston with the set screw.

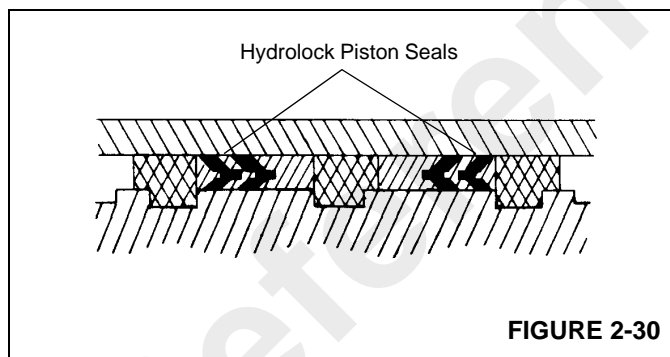

7. Install the replacement hydrolock seals on the outside of the piston. Make sure the "vees" on the two hydrolock seals point at each other (Figure 2-30).

8. Lubricate all parts freely with clean hydraulic oil.

CAUTION

Exercise extreme care when handling the rod. Damage to the rod surface may cause unnecessary maintenance and expense. Also, take care to avoid damaging grooved or gland surfaces or rings or seals during rod insertion.

9. Remove the cover from the barrel. Insert the rod and attached parts into the barrel with a slight twisting motion.
10. Install new gasket material to the cylinder head retainer ring flange as follows.
 - a. Clean the barrel and retainer ring with Loctite cleaning solvent 7070 or similar non-chlorinated solvent.
 - b. Apply a light coating of Loctite primer N7649 to both surfaces. Allow primer to dry for one to two minutes. Primer must be dry. Mating of parts should occur within five minutes.
 - c. Apply gasket material Loctite Master Gasket 518 to one surface. Partial cure is obtained in four hours, with full cure in 48 hours.
11. Using a spanner wrench or chain wrench, screw the head into place in the barrel.

CAUTION

Do not use air pressure to cycle or pressurize the cylinder.

12. Install the retainer plate and pin to the barrel. Tack weld the plate to the barrel.
13. Position the holding valve on the cylinder barrel and secure with four capscrews and washers. Connect tubing to holding valve.
14. Pressurize and cycle the cylinder with hydraulic oil pressure. Test the cylinder at 41,368 kPa/413.6 bar (6000 psi). Check for proper operation and any leakage. Make repairs as needed.

DUAL ROD TELESCOPE CYLINDER

Description

The boom dual rod telescope cylinder (upper telescope cylinder) has a 17.7 cm (7.0 inch) bore. The cylinder is internally ported (rod ported). Oil from the telescope control valve is routed to the cylinder by external lines. Foreign material is prevented from entering the cylinder rod during retraction by a wiper seal in the head. O-ring seals prevent internal and external leakage (Figure 2-33).

The cylinder incorporates two cylinder rods with separate strokes. One rod has a stroke of 736.0 cm (289.8 inches), and one rod has a stroke of 743.7 cm (292.8 inches), which provides a combined overall stroke of 1479.7 cm (582.6 inches).

CAUTION

Do not retract the cylinder completely if it is not attached to the boom. Maintain a spacer that is split or hinged 6.88" long to prevent cylinder from retracting completely.

The cylinder weighs approximately 1249 kg (2753.5 lb) wet.

Maintenance

Disassembly

NOTE: Any maintenance requiring disassembly of the cylinder should include replacement of all cylinder seals and O-rings.

1. Using a spanner wrench, unscrew the outer cylinder head from the cylinder barrel.
-



DANGER

Do not use air pressure to remove the cylinder rod assembly. Use only a source of controlled hydraulic oil pressure if the rod is hard to remove.

CAUTION

Exercise extreme care when handling or setting down the cylinder rod. Do not damage the chrome surface.

2. Remove the cylinder rod assembly from the cylinder barrel and cover the barrel to avoid contamination.
-

CAUTION

When removing seals and rings, avoid scratching grooved and gland surfaces.

NOTE: Aligning discarded seals and rings in the order of disassembly will facilitate installation of new seals and rings.

3. Remove the hydrolock piston seal to gain access to the setscrew securing the piston to the outer cylinder rod.
 4. Remove the setscrew and unscrew the piston from the cylinder rod.
 5. Remove the remaining hydrolock seal and wear rings from the outside of the piston and the O-ring and two backup rings from the inside of the piston.
 6. Remove the spacer from the rod.
 7. Remove the cylinder head from the outer rod.
 8. Remove the O-ring and backup ring from the outside of the head and the wear rings, buffer seal, rod seal, backup ring and the wiper ring from the inside of the head.
 9. Using a spanner wrench, unscrew the inner cylinder head from the outer cylinder rod.
-

CAUTION

Do not use air pressure to remove the cylinder rod assembly. Use only a source of controlled hydraulic oil pressure if the rod is hard to remove.

CAUTION

Exercise extreme care when handling or setting down the cylinder rod. Do not damage the chrome surface.

10. Remove the inner cylinder rod assembly from the outer cylinder rod and cover the opening to avoid contamination.
11. Remove the hydrolock piston seal to gain access to the setscrew securing the piston to the inner cylinder rod.
12. Remove the setscrew and unscrew the piston from the cylinder rod.
13. Remove the remaining hydrolock seal and wear ring from the outside of the piston and the O-ring and two backup rings from the cylinder rod
14. Remove the spacer from the rod and remove the wear ring from the spacer.
15. Remove the cylinder head from the inner rod.
16. Remove the O-ring and backup ring from the outside of the head and the wear rings, buffer seal, deep Z rod seal, backup ring and the wiper ring from the inside of the head.
17. If necessary, remove the holding valve from the inner cylinder rod and from the cylinder barrel.

Inspection

1. Clean all parts with solvent and dry with compressed air. Inspect for damaged or worn parts and replace as required.

CAUTION

Clean all surfaces and remove all burrs and nicks before installing new seals and rings. Replace all damaged or worn parts.

2. Stone out minor blemishes and polish with fine crocus cloth.
3. Clean all with solvent and dry with compressed air any parts that have been stoned and polished.
4. Inspect the barrel for scoring.

Assembly

1. If removed, install the holding valves. Refer to HOLDING VALVES in this section.

CAUTION

When installing new seals and rings, clean all surfaces and carefully remove burrs and nicks. Parts displaying excessive wear or damage should be replaced.

NOTE: Lubricate new seals and rings with clean hydraulic oil.

NOTE: Locate the gap of wear ring 180 degrees with respect to each other.

2. Install the wiper ring into the cylinder head.
3. Install the wear rings into the head (Figure 2-31).

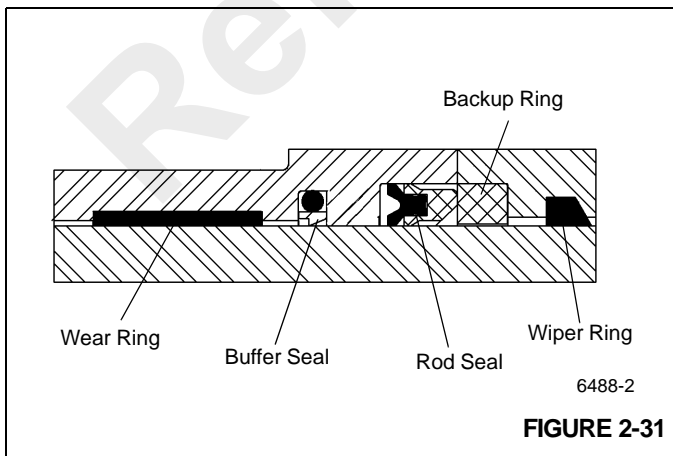

FIGURE 2-31

CAUTION

Improper seal installation can cause faulty cylinder operation.

4. Install the buffer seal, rod seal and backup ring inside the head ensuring the seals are assembled properly and installed in the correct direction (Figure 2-31).
5. Install the O-ring and backup ring onto the outside of the head.
6. Install the inner cylinder head onto the inner cylinder rod.
7. Install the wear ring onto the spacer and install the spacer onto the rod.
8. Install the O-ring and backup rings onto the rod and install the piston onto the inner cylinder rod. Secure the piston in place with the setscrew.

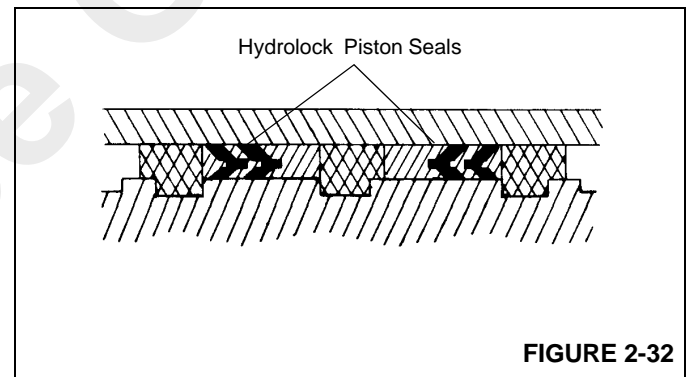

FIGURE 2-32

9. Install the hydrolock seals onto the piston (Figure 2-32).

CAUTION

Avoid scratching or damaging the grooved and gland surfaces or the seals and rings.

10. Lubricate the inner cylinder rod assembly with clean hydraulic oil and install the rod assembly into the outer cylinder rod with a slight twisting motion.
11. Using a spanner wrench, secure the inner cylinder head to the outer cylinder rod.
12. Install the wiper ring into the outer cylinder head.
13. Install the wear rings into the head.

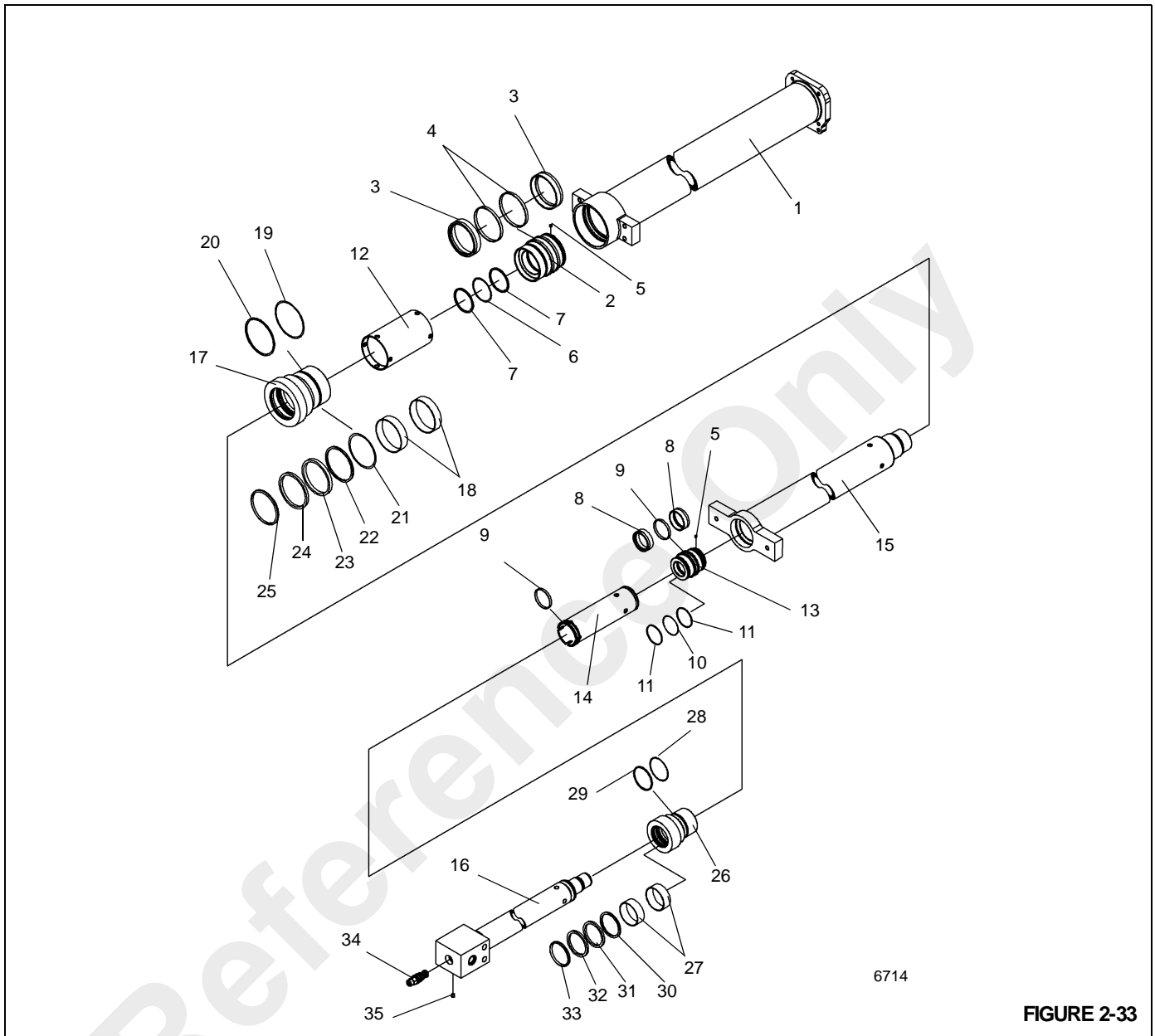

6714

FIGURE 2-33

Item	Description
1	Barrel
2	Piston
3	Seal
4	Wear Ring
5	Setscrew
6	O-ring
7	Backup Ring
8	Hydrolock Seal
9	Wear Ring

Item	Description
10	O-ring
11	Backup Ring
12	Spacer
13	Piston
14	Spacer
15	Rod
16	Rod
17	Head
18	Wear Ring

Item	Description
19	O-ring
20	Backup Ring
21	Buffer Seal
22	Backup Ring
23	Rod Seal
24	Backup Ring
25	Wiper Ring
26	Head
27	Wear Ring
28	O-ring
29	Backup Ring
30	Seal
31	Seal
32	Backup Ring
33	Wiper Ring
34	Holding Valve
35	Plug

15. Install the O-ring and backup ring onto the outside of the outer cylinder head.
16. Install the outer cylinder head onto the outer cylinder rod.
17. Install the spacer onto the rod.
18. Install the O-ring and backup rings into the inside of the piston and install the piston onto the outer cylinder rod. Secure the piston in place with the setscrew.

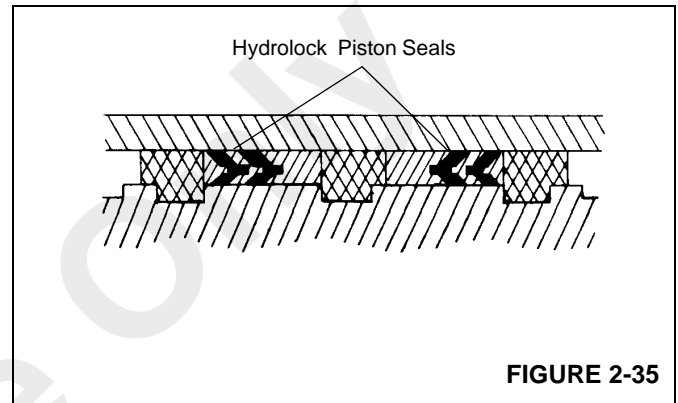

FIGURE 2-35

19. Install the hydrolock seals and wear rings onto the piston (Figure 2-35).

CAUTION

Improper installation of seals could cause faulty cylinder operation.

14. Install the buffer seal, backup rings and rod seal into the head ensuring the seals are assembled properly and installed in the correct direction (Figure 2-34).

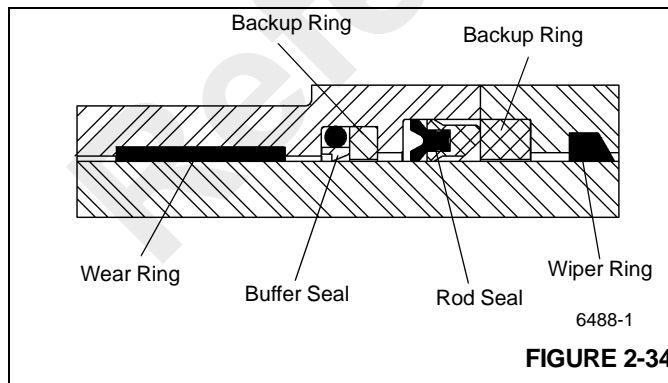

FIGURE 2-34

CAUTION

Avoid scratching or damaging the grooved or gland surfaces or the ring and seals.

20. Lubricate the outer cylinder rod assembly with clean hydraulic oil and install the rod assembly into the cylinder barrel with a slight twisting motion.
21. Using a spanner wrench, secure the outer cylinder head to the cylinder barrel.



DANGER

Do not use air pressure to cycle or pressurize the cylinder.

22. Pressurize and cycle the cylinder with hydraulic oil pressure. Test the cylinder at 32,750 kPa/327.5 bar (4750 psi). Check for proper operation and any leakage.

AXLE OSCILLATION LOCKOUT CYLINDER

Description

The two oscillation lockout cylinders (Figure 2-36) standard or (Figure 2-37) CE Option, each have 12.7 cm (5 inch) diameter bores. The retracted length of each cylinder is 48.8 cm (19.25 inches) from the center of the lug holes to the center of the barrel bushing. The extended length of each cylinder from the center of the lug holes to the center of the barrel bushing is 65.5 cm (25.8 inches). Its stroke is 16.8 cm (6.62 inches). A wiper ring prevents foreign material from entering each cylinder. O-rings and other seals prevent internal and external leakage.

The cylinder weighs approximately 38.8 kg (85.5 lb).

Maintenance

Disassembly

NOTE: Any maintenance requiring disassembly of the cylinder should include replacement of all cylinder seals.

1. Clean away all dirt from the head. Place protective padding around the rod near the head to prevent damaging the chrome. Using a spanner wrench, unscrew the head from the barrel.



DANGER

Do not use air pressure to remove the rod. Use only a source of controlled hydraulic oil pressure if the rod is hard to remove.

CAUTION

Exercise extreme care when handling or setting down the rod. Do not damage the chrome surface.

2. Open both ports on the side of the cylinder barrel and drain the oil from the cylinder.
3. Secure cylinder barrel in a chain vise without putting pressure on the side feeder tube preferably in the vertical position with the rod assembly up.
4. Using a screwdriver, or 1/4 inch wrench, remove the screw from the head.
5. Remove the grease fitting from the rod
6. Turn the head counterclockwise with a fitted spanner wrench until the threads disengage.

NOTE: Residual oil will spill over the end of the barrel when the rod assembly is extended. Make provisions to contain the oil.

7. Using a hoist, extend the rod assembly slowly until the piston is free of the barrel.

8. Remove the rod and attached parts from the barrel.

NOTE: Cover the barrel opening to avoid contamination.

CAUTION

When removing seals and rings, avoid scratching the grooved and gland surfaces.

9. Remove the lip seals and wear ring from the outside of the piston.

NOTE: Arranging discarded seals and rings in the order of disassembly will aid in installation of new seals and rings. Pay attention to how each seal and ring is installed to avoid installing replacement seals and rings improperly.

10. Remove the retaining ring from the rod.

11. Remove the head from the rod. Remove the O-ring and backup ring from the outside of the head. Remove the wear ring, buffer seal, lip seal and wiper ring from the inside of the head.

Inspection

1. Inspect the rod. There should be no scratches or pits deep enough to catch the fingernail. Pits that go to the base metal are unacceptable. Chrome should be present over the entire surface of the rod. If lack of chrome on rod, the rod should be replaced.
2. Inspect rod for straightness. Determine if it can be straightened or must be replaced.
3. Inspect the head. Visually inspect the inside bore for scratching or polishing. Deep scratches are unacceptable. Polishing indicates uneven loading, and the bore should be checked for out-of-roundness.
4. Inspect the piston. Visually inspect the outside surface for scratches or polishing. Deep scratches are unacceptable. Polishing indicates uneven loading, and the diameter should be checked for out-of roundness.
5. Inspect the barrel carefully for scoring. If barrel is scored, it must be repaired or replaced.
6. Thoroughly rinse parts, allow to drain, and wipe with a lint-free rag. Inspect all parts for serviceability.

CAUTION

Before installing new seals and rings, clean all surfaces and carefully remove burrs and nicks. Parts displaying excessive wear or damage should be replaced.

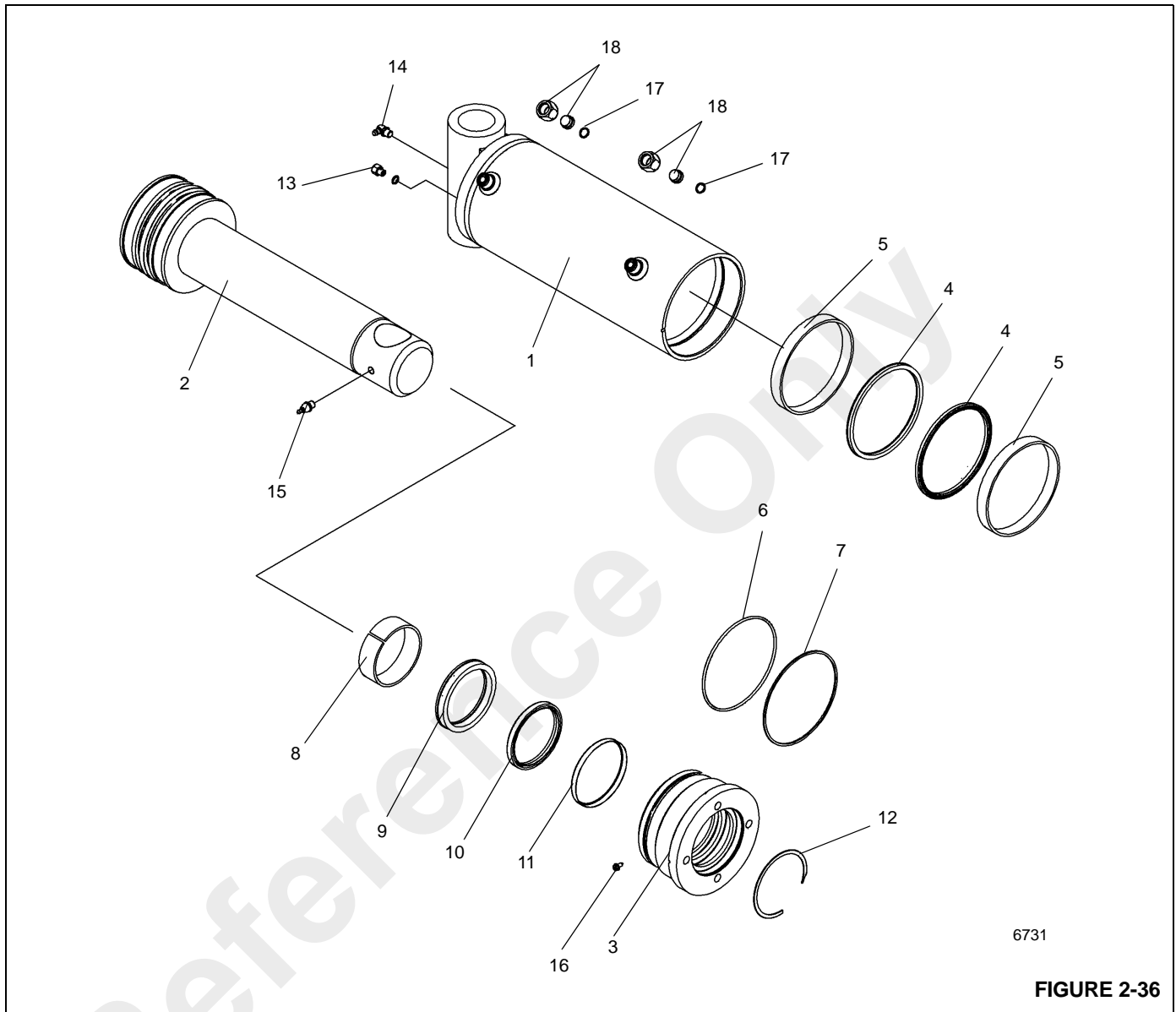

6731

FIGURE 2-36

Item	Description
1	Barrel
2	Rod
3	Head
4	Lip Seal Ring
5	Wear Ring
6	O-ring
7	Backup Ring
8	Buffer Ring
9	Wear Ring

Item	Description
10	Lip Seal Ring
11	Wiper Ring
12	Retainer Ring
13	Bleeder Plug
14	Grease Fitting
15	Grease Fitting
16	Screw
17	O-ring
18	Cap Assembly

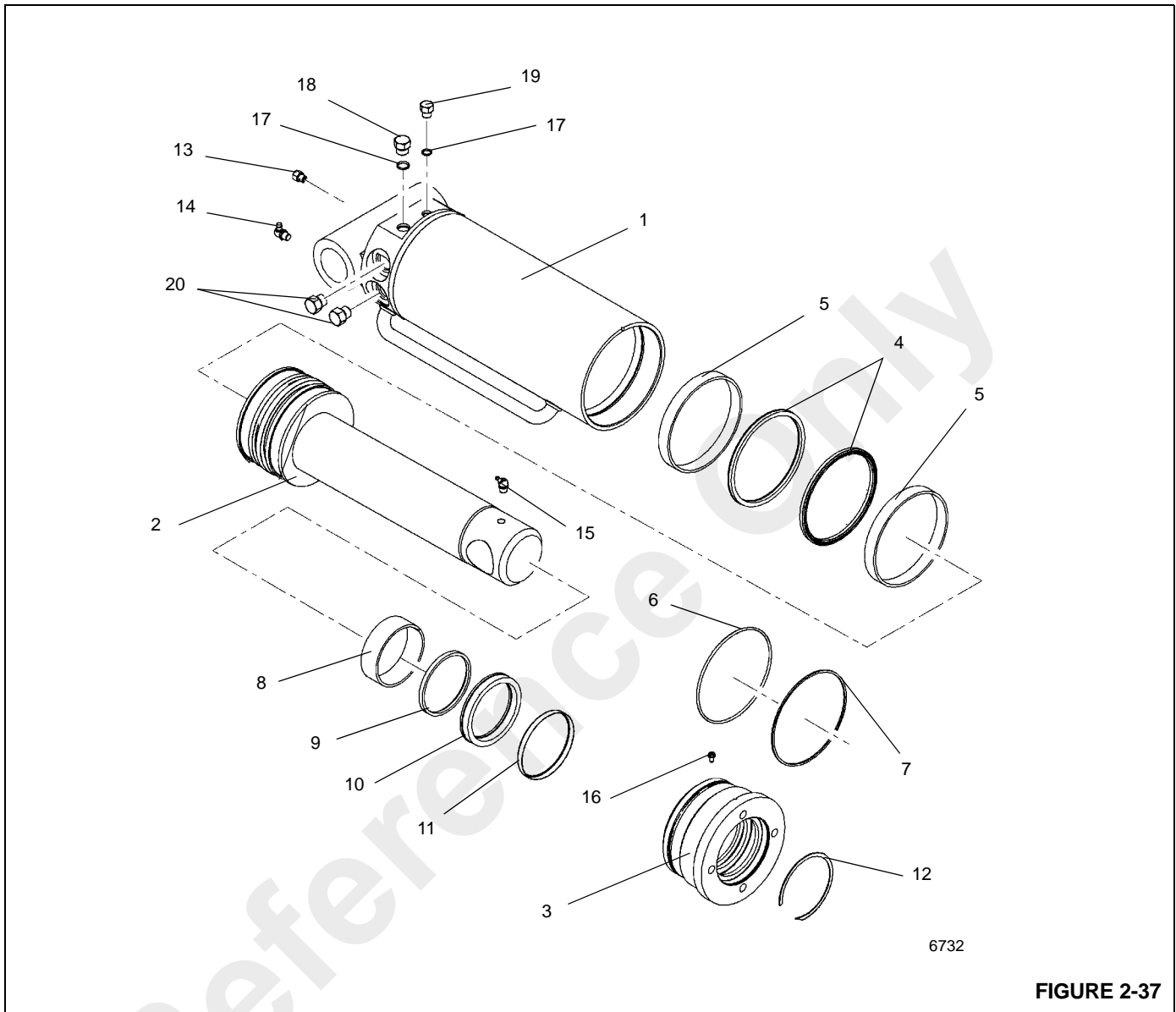

FIGURE 2-37

Item	Description
1	Barrel
2	Piston
3	Head
4	Wear Ring
5	Setscrew
6	O-ring
7	Backup Ring
8	Hydrolock Seal
9	Wear Ring
10	O-ring

Item	Description
11	Backup Ring
12	Spacer
13	Piston
14	Spacer
15	Rod
16	Rod
17	Head
18	Wear Ring
19	Plug
20	Check Valve

7. Stone out minor blemishes and polish with a fine crocus cloth.
8. Clean with solvent and dry with compressed air any parts that have been stoned and polished.

Assembly

CAUTION

When installing new seals and rings, avoid stretching seals or scratching the grooved or gland surfaces. Make sure parts are clean before and during assembly. Make sure seals and rings are installed in the proper order.

NOTE: Lubricate seals and rings with clean hydraulic oil.

1. Install the replacement wiper ring, lip seal, buffer seal and wear ring in the inside of the head.
2. Install the replacement O-rings and backup ring on the outside of the head.
3. Install the lip seals and wear ring onto the outside of the piston.
4. Lubricate the rod with clean hydraulic oil.
5. Slide the head, onto the rod. Tap the head with a rubber mallet to engage the seals. Push the head about half way down the length of the rod assembly.
6. Remove the cover from the barrel.

CAUTION

Exercise extreme care when handling the rod. Damage to the rod surface may cause unnecessary maintenance and expense. Also, take care to avoid damaging grooved or gland surfaces or rings or seals during rod insertion.

7. With a hoist, raise the rod assembly back into a vertical position taking care not to damage the OD seals on the head and piston.
8. Lubricate the OD seals on the piston and head with clean light oil and lower the assembly into the barrel. Stop just before the head enters the barrel.
9. Place a spanner wrench on the head and turn counterclockwise until the thread clicks, then reverse direction to clockwise and thread in until there is no gap between the head shoulder and top of barrel.
10. Install the retaining ring onto the rod.
11. Install the setscrew into the head.

CAUTION

Do not use air pressure to cycle or pressurize the cylinder.

12. Pressurize and cycle the cylinder with hydraulic oil pressure. Test the cylinder at 25,856 kPa/259 bar (3750 psi). Check for proper operation and any leakage. Make repairs as needed.

STEER CYLINDER

Description

The steer cylinders (Figure 2-38) are mounted on the axles, two cylinders on each axle. The front and rear steer cylinders each have 6.3 cm (2.5 inch) diameter bores. The front and rear steer cylinders each have a retracted length of 53.1cm (20.94 inches) from bushing center to bushing center. The front and rear steer cylinders each have an extended length of 74.1cm (29.19 inches) from bushing center to bushing center. Each cylinder has a stroke of 20.9 cm (8.25 inches). A wiper ring prevents foreign material from entering each cylinder. O-rings and other seals prevent internal and external leakage.

The cylinder weighs approximately 9.07 kg (19.9 lb).

Maintenance

Disassembly

NOTE: Any maintenance requiring disassembly of the cylinders should include replacement of all seals and rings. A seal kit will supply the required items.

1. Secure the cylinder in a clean work area by use of clamps or a chain vise to prevent rolling.
2. Retract the cylinder fully to avoid damaging the rod during removal.

NOTE: Mark or note the piston and head relationship to the rod and barrel.

3. Clean away all dirt from the head. Place protective padding around the rod near the head to prevent damaging the chrome during head removal.



DANGER

Do not use air pressure to remove the rod. Use only a source of controlled hydraulic oil pressure if the rod is hard to move.

CAUTION

Exercise extreme care when handling or setting down the rod. Damage to the rod surface may cause unnecessary maintenance and expense.

4. Position the rod mount with the ports facing down.
5. Using a means of collecting the oil, remove the port plugs and allow cylinder to drain.
6. Rapidly pull the rod against the head to free it. Remove rod and attached parts from the barrel. Place the rod on a surface that will not damage the chrome or allow the rod assembly to drop.

NOTE: Cover the barrel opening to avoid contamination.

CAUTION

When removing seals and rings, avoid scratching the grooved and gland surfaces.

7. Remove the seal from the outside of the piston.

NOTE: Arranging discarded seals and rings in the order of disassembly will aid in installation of new seals and rings. Pay attention to how each seal and ring is installed to avoid installing replacement seals and rings improperly.

8. Loosen and remove the nut securing the piston. Remove the piston from the rod.
9. Remove the O-ring from the inside of the piston.
10. Remove the head from the rod. Remove the O-ring and backup ring from the outside of the head. Remove the wiper ring and the rod seal from the inside of the head.

Inspection

1. Clean all parts with solvent and dry with compressed air. Inspect for damaged or worn parts and replace as required.

CAUTION

Clean all surfaces and remove all burrs and nicks before installing new seals and rings. Replace all damaged or worn parts.

2. Stone out minor blemishes and polish with fine crocus cloth.
3. Clean all with solvent and dry with compressed air any parts that have been stoned and polished.
4. Inspect the barrel for scoring.

Assembly

CAUTION

When installing new seals and rings, clean all surfaces and carefully remove burrs and nicks. Parts displaying excessive wear or damage should be replaced.

NOTE: Lubricate new seals and rings with clean hydraulic oil.

1. Install the replacement wiper ring into the head.
2. Install the rod seal in the inside of the head. Make sure the lips of the seal face the piston.

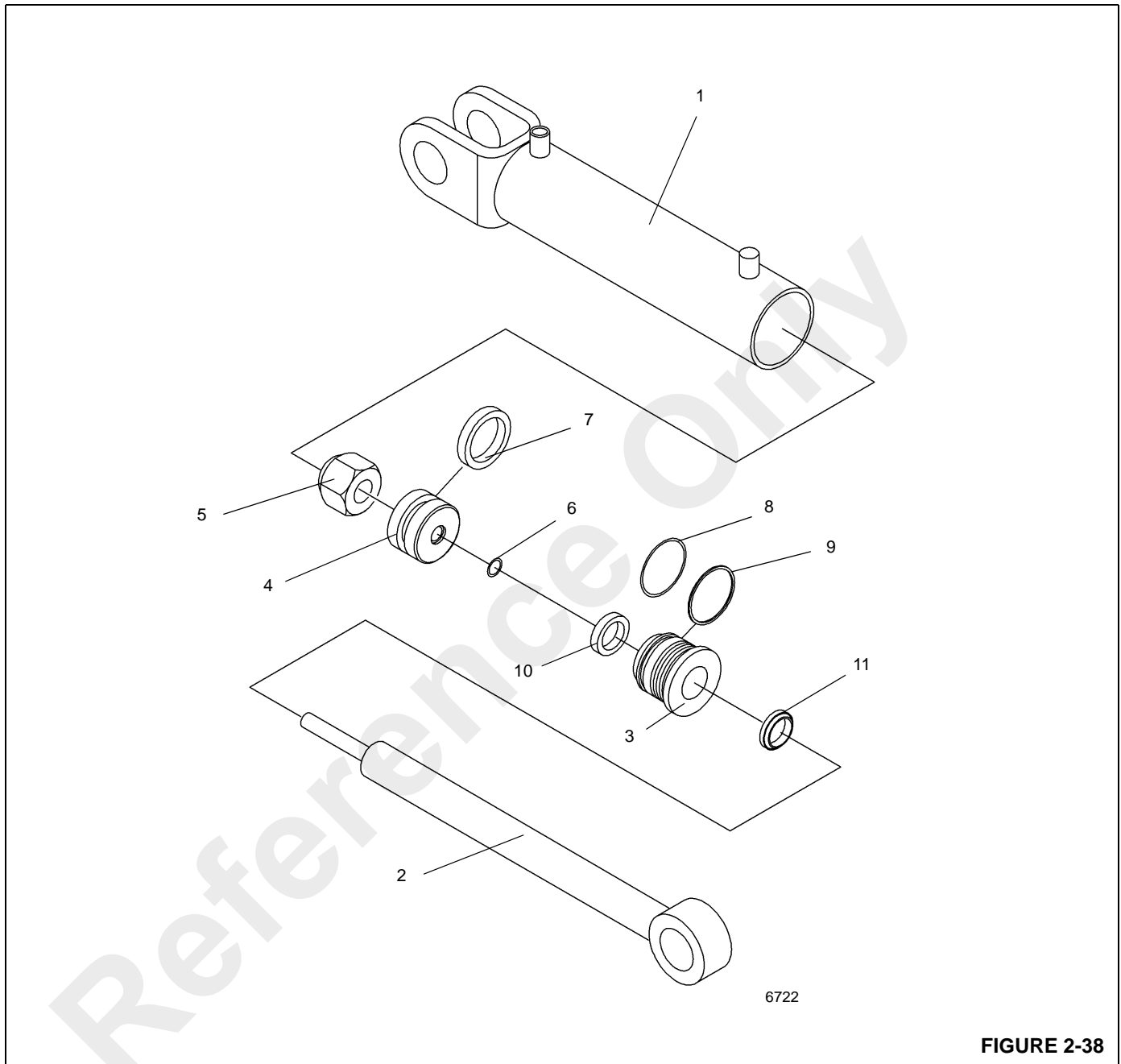

FIGURE 2-38

Item	Description
1	Barrel
2	Piston
3	Head
4	Wear Ring
5	Setscrew
6	O-ring

Item	Description
7	Piston Ring Seal
8	O-ring
9	Backup Ring
10	Seal Rod Ring
11	Wiper Ring

3. Install the O-ring and backup ring onto the outside of the head.

4. Install the O-ring in the inside of the piston.
5. Lubricate the rod with clean hydraulic oil.
6. Slide the head, larger OD end first, onto the rod.
7. Install the piston onto the rod. Secure the piston with the nut. Lubricate the threads and torque the nut to 176.2 ± 6.7 Nm (130 ± 5 lb-ft).
8. Install the seal on the outside of the piston.
9. Lubricate all parts freely with clean hydraulic oil.
10. Remove the cover from the barrel. Insert the rod and attached parts into the barrel with a slight twisting motion.
11. Push the head into the barrel. Torque the head 27.1 Nm (20 lb-ft).

CAUTION

Exercise extreme care when handling the rod. Damage to the rod surface may cause unnecessary maintenance and expense. Also, take care to avoid damaging grooved or gland surfaces or rings or seals during rod insertion.

CAUTION

Do not use air pressure to cycle or pressurize the cylinder.

12. Pressurize and cycle the cylinder with hydraulic oil pressure. Test the cylinder at 20,684 kPa/206.8 bar (3000 psi). Check for proper operation and any leakage. Make repairs as needed.

OUTRIGGER EXTENSION CYLINDER

Description

The four extension cylinders (Figure 2-1) have 6.4 cm (2.5-inch) diameter bores. Each cylinder has a retracted length of 218.1 ± 0.30 cm (85.88 ± 0.12 inches) from the center of the rod bushing to the center of the barrel bushing. Each cylinder's extended length is 403.5 cm (157.87 inches). The stroke of each cylinder is 185.4 cm (73.0 inches). A wiper ring prevents foreign material from entering each cylinder. O-rings and other seals prevent internal and external leakage.

The cylinder weighs approximately 42 kg (112.5 lb).

Maintenance

Disassembly

NOTE: Any maintenance requiring disassembly of the cylinders should include replacement of all seals and rings. A seal kit will supply the required items.

1. Remove all dirt, grease and other contaminants from around the ports and the head



DANGER

Do not use air pressure to remove the rod. Use only a source of controlled hydraulic oil pressure if the rod is hard to move.

CAUTION

Exercise extreme care when handling or setting down the rod. Damage to the rod surface may cause unnecessary maintenance and expense.

2. Using a spanner wrench, unscrew the cylinder head.
3. Remove rod and attached parts from the barrel.

NOTE: Cover the barrel opening to avoid contamination.

CAUTION

When removing the seals and rings, avoid scratching the grooved and gland surfaces.

4. Remove the wear rings and piston seal from the outside of the piston.

NOTE: Arranging discarded seals and rings in the order of disassembly will aid in installation of new seals and rings. Pay attention to how each seal and ring is installed to avoid installing replacement seals and rings improperly.

5. Remove the nut from the rod.

6. Remove the piston and spacer from the rod.
7. Remove the O-ring and the backup ring from the outside of the head.
8. Remove the rod seal, wear ring and wiper ring from the inside of the head.
9. Remove the O-ring from the rod.

Inspection

1. Clean all parts with solvent and dry with compressed air. Inspect all parts for serviceability.
2. Inspect the barrel carefully for scoring. If barrel is scored, it must be repaired or replaced.
3. Check rod's piston area for damage. If it is damaged, determine if it can be repaired or must be replaced.
4. Inspect rod for straightness. Determine if it can be straightened or must be replaced.

CAUTION

Before installing new seals and rings, clean all surfaces and carefully remove burrs and nicks. Parts displaying excessive wear or damage should be replaced.

5. Stone out minor blemishes and polish with a fine crocus cloth.
6. Clean with solvent and dry with compressed air any parts that have been stoned and polished.

Assembly

CAUTION

When installing new seals and rings, avoid stretching seals or scratching the grooved or gland surfaces. Make sure parts are clean before and during assembly. Make sure seals and rings are installed in the proper order.

NOTE: Lubricate seals and rings with clean hydraulic oil.

1. Install the replacement wear ring, rod seal and wiper ring in the inside of the head.
2. Install the replacement O-ring and the backup ring on the outside of the head.
3. Install the O-ring onto the rod.
4. Lubricate the rod with clean hydraulic oil.
5. Slide the head onto the rod.
6. Install the spacer and piston on the rod.
7. Install the locknut onto the rod.

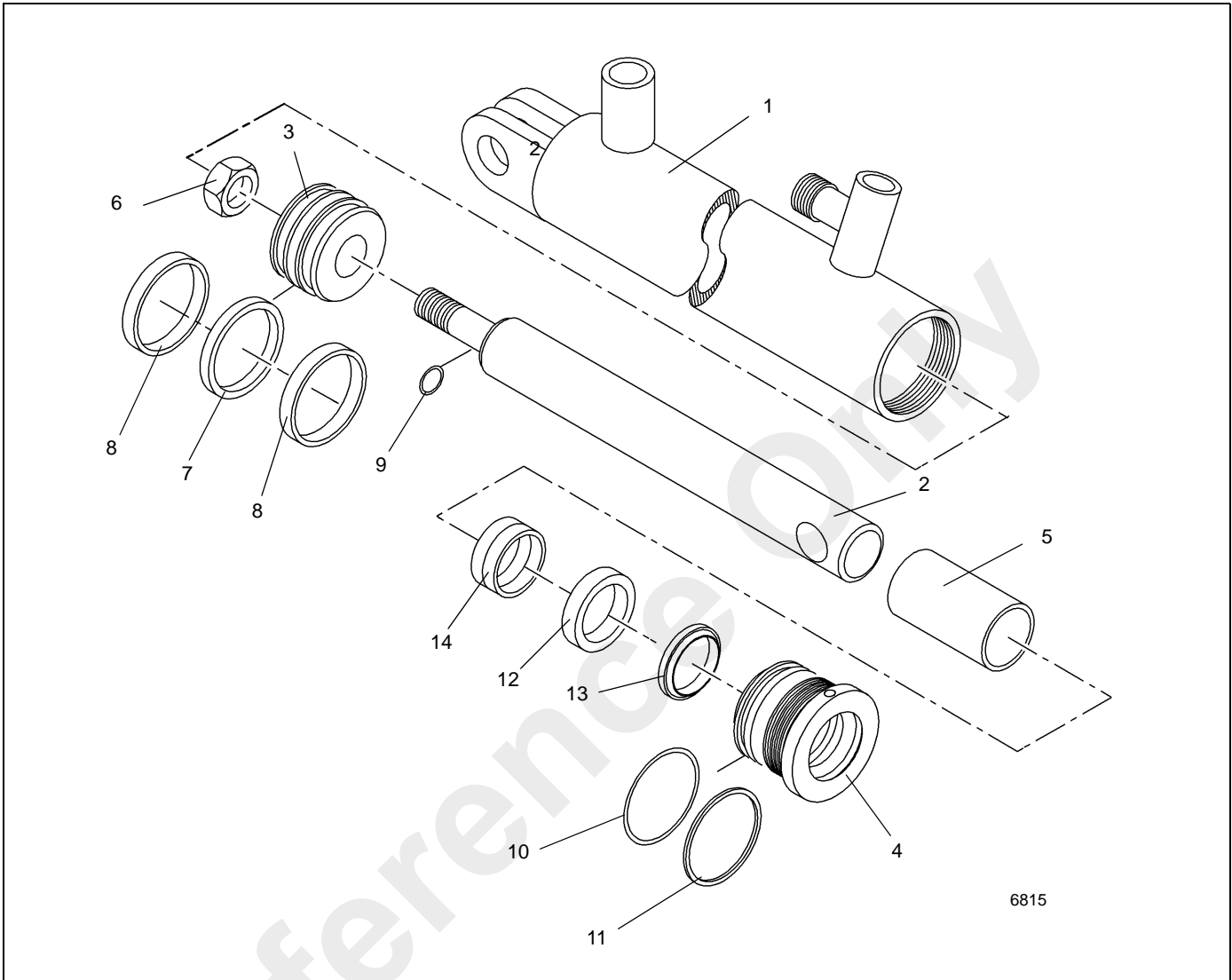

6815

1	Barrel	8	Wear Ring
2	Rod	9	O-ring
3	Piston	10	O-ring
4	Head	11	Backup Ring
5	Spacer	12	Seal
6	Nut	13	Wiper
7	Piston Seal	14	Wear Ring

8. Install the replacement piston seal and wear rings on the outside of the piston.
9. Lubricate all parts freely with clean hydraulic oil.
10. Remove the cover from the barrel. Insert the rod and attached parts into the barrel with a slight twisting motion.
11. Push the head into the barrel.

CAUTION

Exercise extreme care when handling the rod. Damage to the rod surface may cause unnecessary maintenance and expense. Also, take care to avoid damaging grooved or gland surfaces, rings or seals during rod insertion.

CAUTION

Do not use air pressure to cycle or pressurize the cylinder.

12. Pressurize and cycle the cylinder with hydraulic oil pressure. Test the cylinder at 20,700 kPa (270 bar) (3000 psi). Check for proper operation and any leakage. Make repairs as needed.

Reference Only

OUTRIGGER JACK CYLINDER

Description

The four outrigger jack cylinders (Figure 2-39) each have a hollow rod for internal porting. Each cylinder has a 10.1 cm (4.0 inch) diameter bore. A port block is welded to the rod of each cylinder and a pilot operated check valve is threaded into each port block. The retracted length of the cylinder from the end of the barrel to the center of the rod's port block rod bushing is 122.2 ± 30.8 cm (48.12 ± 12 inches). The extended length of the cylinder from the end of the barrel to the center of the rod's port block rod bushing is 185.7 cm (73.12 inches). Its stroke is 63.5 cm (25 in). A wiper ring prevents foreign material from entering the cylinder. O-rings and other seals prevent internal and external leakage.

The cylinder weighs approximately 64.6 kg (142.52 lb).

Maintenance

Disassembly

NOTE: Any maintenance requiring disassembly of the cylinder should include replacement of all cylinder seals.

1. Clean away all dirt from the head. Place protective padding around the rod near the head to prevent damaging the chrome. Using a spanner wrench, unscrew the head from the barrel.



DANGER

Do not use air pressure to remove the rod. Use only a source of controlled hydraulic oil pressure if the rod is hard to remove.

CAUTION

Exercise extreme care when handling or setting down the rod. Do not damage the chrome surface.

2. Open ports on the side of the cylinder barrel and drain the oil from the cylinder.
3. Secure cylinder barrel in a chain vise without putting pressure on the side feeder tube in the vertical position with the rod assembly up.
4. Using a 5/32 inch Allen wrench, remove the setscrew on the barrel OD at the head.

NOTE: Oil or oil/air mixture may rapidly exit out of the ports during rod extension. Shield the work area from the exiting oil.

5. With the ports open, extend the rod assembly with a hoist enough to access the top of the head with spanner wrench. Do not extend completely.

6. Turn the head counterclockwise with a fitted spanner wrench until the threads disengage.
7. Extend the rod assembly slowly until the piston is free of the barrel assembly. Place the rod assembly horizontally on a workbench taking care not to damage the surface of the rod.

NOTE: Cover the barrel opening to avoid contamination.

8. Remove the piston seal to gain access to the piston setscrew. Using a 3/16 inch Allen wrench, remove the setscrew from the piston.
9. Remove the piston by turning counterclockwise with a fitted spanner wrench.
10. Remove the spacer and head from the rod.

CAUTION

When removing seals and rings, avoid scratching the grooved and gland surfaces.

11. Remove the seal assembly from the outside of the piston and the O-ring and backup rings from the inside of the piston.

NOTE: Arranging discarded seals and rings in the order of disassembly will aid in installation of new seals and rings. Pay attention to how each seal and ring is installed to avoid installing replacement seals and rings improperly.

12. Remove the O-ring and backup ring from the outside of the head. Remove the wear rings, buffer seal, rod seal and wiper ring from the inside of the head.

Inspection

1. Inspect the rod. There should be no scratches or pits deep enough to catch the fingernail. Pits that go to the base metal are unacceptable. Chrome should be present over the entire surface of the rod. If lack of chrome on rod, the rod should be replaced.
2. Inspect rod for straightness. Determine if it can be straightened or must be replaced.
3. Inspect the head. Visually inspect the inside bore for scratching or polishing. Deep scratches are unacceptable. Polishing indicates uneven loading, and the bore should be checked for out-of-roundness.
4. Inspect the piston. Visually inspect the outside surface for scratches or polishing. Deep scratches are unacceptable. Polishing indicates uneven loading, and the diameter should be checked for out-of-roundness.
5. Inspect the barrel carefully for scoring. If barrel is scored, it must be repaired or replaced.

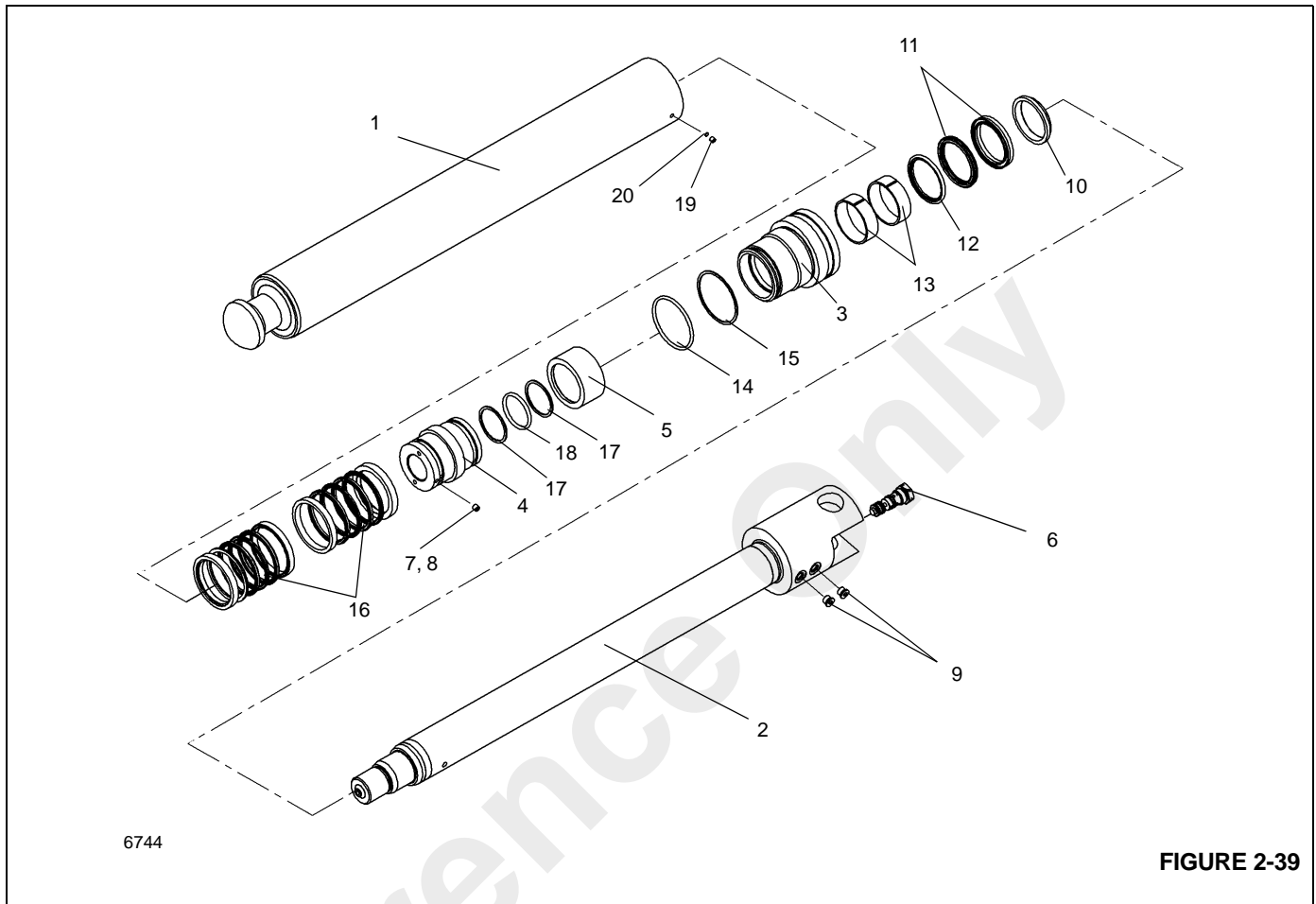

6744

FIGURE 2-39

1	Barrel	11	Rod Seal
2	Rod	12	Buffer Seal
3	Head	13	Wear Ring
4	Piston	14	O-ring
5	Spacer	15	Backup Ring
6	Check Valve	16	Seal Assembly
7	Setscrew	17	Backup Ring
8	Insert	18	O-ring
9	Plug	19	Setscrew
10	Wiper Ring	20	Insert

6. Thoroughly rinse parts, allow to drain, and wipe with a lint-free rag. Inspect all parts for serviceability.

7. Stone out minor blemishes and polish with a fine crocus cloth.

8. Clean with solvent and dry with compressed air any parts that have been stoned and polished.

CAUTION

Before installing new seals and rings, clean all surfaces and carefully remove burrs and nicks. Parts displaying excessive wear or damage should be replaced.

Assembly

CAUTION

When installing new seals and rings, avoid stretching seals or scratching the grooved or gland surfaces. Make sure parts are clean before and during assembly. Make sure seals and rings are installed in the proper order.

NOTE: Lubricate seals and rings with clean hydraulic oil.

1. Install the replacement wiper ring, rod seal, buffer seal and wear rings in the inside of the head.
2. Install the replacement O-ring and backup ring on the outside of the head.
3. Lubricate the rod with clean hydraulic oil.
4. Slide the head, onto the rod. Tap the head with a rubber mallet to engage the seals. Push the head about half way down the length of the rod assembly.
5. Install the spacer onto the rod with the ID lip at the piston end.
6. Install the setscrew in the piston with a 3/16 inch Allen wrench until hand tight. Install the seal assemblies onto the piston.
7. Remove the cover from the barrel.

CAUTION

Exercise extreme care when handling the rod. Damage to the rod surface may cause unnecessary maintenance and expense. Also, take care to avoid damaging grooved or gland surfaces or rings or seals during rod insertion.

8. With a hoist, raise the rod assembly back into a vertical position taking care not to damage the OD seals on the head and piston.
9. Lubricate the OD seals on the piston and head with clean light oil and lower the assembly into the barrel. Stop just before the head enters the barrel.
10. Place a spanner wrench on the head and turn counterclockwise until the thread clicks, then reverse direction to clockwise and thread in until there is no gap between the head shoulder and top of barrel.
11. Using a 5/32 inch Allen wrench install the setscrew into the head until hand tight.
12. Slowly lower the rod down to the fully retracted position.

CAUTION

Do not use air pressure to cycle or pressurize the cylinder.

13. Pressurize and cycle the cylinder with hydraulic oil pressure. Test the cylinder at 31,026 kPa/310.2 bar (4500 psi). Check for proper operation and any leakage. Make repairs as needed.

SECTION 3 ELECTRIC SYSTEM

SECTION CONTENTS

Description	3-1	Troubleshooting Accessories	3-6
General	3-1	Alternator Replacement	3-7
Alternator	3-1	Starter Replacement	3-7
Batteries	3-1	Battery Replacement	3-8
Fuse Panel	3-2	Relay Panel Component Replacement	3-8
Relays	3-3	Rocker Switch Replacement	3-8
Maintenance	3-4	Ignition Switch Replacement	3-9
General	3-4	Turn Signal Lever and Transmission Shift Lever Replacement	3-10
General Troubleshooting	3-4	Windshield Wiper Assembly Replacement	3-12
Troubleshooting Swivel-Caused Electrical Problems	3-4	Windshield Washer Assembly Replacement	3-13
Connector Troubleshooting	3-4	Skylight Wiper Assembly Replacement	3-13
Troubleshooting Engine Starting Problems	3-5	Appendix A: Crane Control System (CCS)	
Troubleshooting Engine Charging Problems	3-5	Fault Codes	3-16

DESCRIPTION

General

The electrical system is 24-volt operation with 24-volt starting, consisting of an alternator and two lead-acid batteries. The system is the single wire ground return type, using the machine's structure as ground

Alternator

The alternator is mounted on the engine and is belt driven. It is a 70 ampere alternator with an integral transformer - rectifier unit. When the engine is running, and the alternator is turning, the alternator's 24-volt output terminal supplies the crane's electrical circuits. The output terminal also supplies the current to recharge the batteries and maintains them at a full state of charge.

Batteries

The batteries are located in a box on the left side of the crane (1) (Figure 3-1). The batteries are the maintenance free type and completely sealed except for a small vent hole in the side. The vent hole allows what small amount of gases that are produced in the battery to escape. On some batteries, a

test indicator located on the top of the battery is used to determine if the battery can be tested in case of a starting problem.

There is a battery disconnect switch (1) (Figure 3-2) located to the right on the battery box.

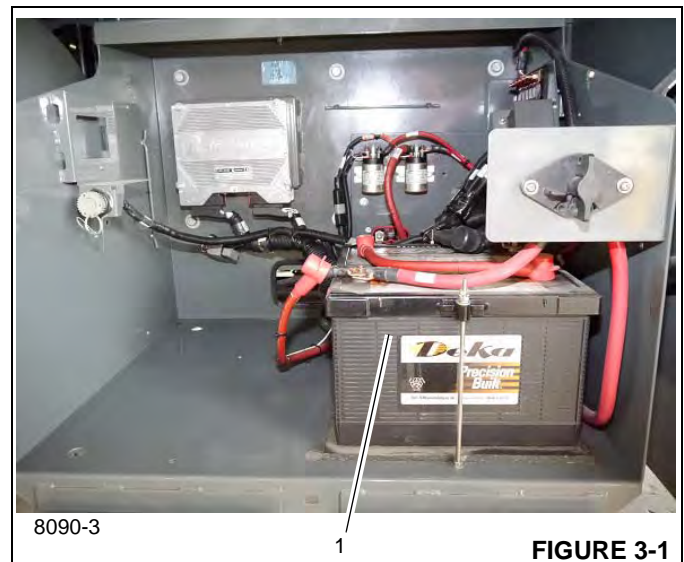

FIGURE 3-1



8090-1B

FIGURE 3-2

Fuse Panel

Fuses are located behind the seat in the cab (1) (Figure 3-3). In the battery box fuse panel (3) (Figure 3-4) and in the battery box (4).



8091-1

FIGURE 3-3

The following fuse assignments apply:

Table 3-1: Superstructure Cab Power Panel

Fuse	Protects	Amps	Location
F1	Dome Light	5	(Figure 3-3)
F2	ACC Power Outlet/ Heater Motor	10	(Figure 3-3)
F3	Work Lights	10	(Figure 3-3)
F4	Steering Column Power	5	(Figure 3-3)
F5	Key Switch Power	10	(Figure 3-3)
F6	Turntable Module Battery Power	15	(Figure 3-3)
F7	Master/Cab Slave Module Battery Power	15	(Figure 3-3)
F8	Skylight Wiper	10	(Figure 3-3)
F9	Turntable Option Module Battery Power	15	(Figure 3-3)
F10	Turntable Option Module Battery Power	15	(Figure 3-3)
F11	Turntable Module Battery Power	15	(Figure 3-3)
F12	Diagnostic Tool Power	15	(Figure 3-3)
F13	Accessory Lights Power	15	(Figure 3-3)
F14	Oil Cooler	25	(Figure 3-3)
F15	Heater/AC Panel	10	(Figure 3-3)
F16	Circulating Fan	5	(Figure 3-3)
F17	Joystick/Jog dial/ Operator Display Power	5	(Figure 3-3)
F18	Master/Cab Slave Module PCB Power	5	(Figure 3-3)
F19	Turntable Module PCB Power	5	(Figure 3-3)
F20	Spare		(Figure 3-3)

Table 3-2 Superstructure Cab Fuse Box

Fuse	Protects	Amps	Location
F1	Keyswitch Ignition Relay	3	(Figure 3-3)
F2	Open		(Figure 3-3)
F3	Ignition On Signal	3	(Figure 3-3)
D1	Keyswitch Ignition On Signal		(Figure 3-3)
D2	Brake Pedal Press Switch Signal		(Figure 3-3)
D3	Hazard Lights On Switch Signal		(Figure 3-3)
D4	Marker Lights On Switch Signal		(Figure 3-3)
D5	Horn On Signal		(Figure 3-3)

Table 3-3: Carrier Fuses and Relays

Fuse	Protects	Amps	Location
F1	Superstructure Module PCB Power	20	(Figure 3-4)
F2	CraneStar Power	5	(Figure 3-4)
F3	Diagnostic Tool Power	5	(Figure 3-4)
F4	Carrier Module Battery Power	15	(Figure 3-4)
F5	Carrier Module Battery Power	15	(Figure 3-4)
F6	Engine ECM Power	30	(Figure 3-4)
F7	Relay Power	10	(Figure 3-4)
F8	Reverse Power	15	(Figure 3-4)
F9	Carrier Module PCB Power	15	(Figure 3-4)
KC1	Headlight Relay		(Figure 3-4)
KC2	Starter Lockout Relay		(Figure 3-4)
KC3	Reverse Relay		(Figure 3-4)
KC4	Ignition On Relay		(Figure 3-4)

Table 3-4: Carrier Fuses and Relays

Fuse	Protects	Amps	Location
F51	Alternator	100	(Figure 3-4)
F52	Swivel	100	(Figure 3-4)
F53	Swivel	100	(Figure 3-4)
F54	Swivel	100	(Figure 3-4)
F55	Main Power	125	(Figure 3-4)
F56	Grid Heater Power	100	(Figure 3-4)

Relays

The relays are located at the back of the battery box (Figure 3-4): relay K-301 start relay (1) and relay K-302 grid heater relay (2).

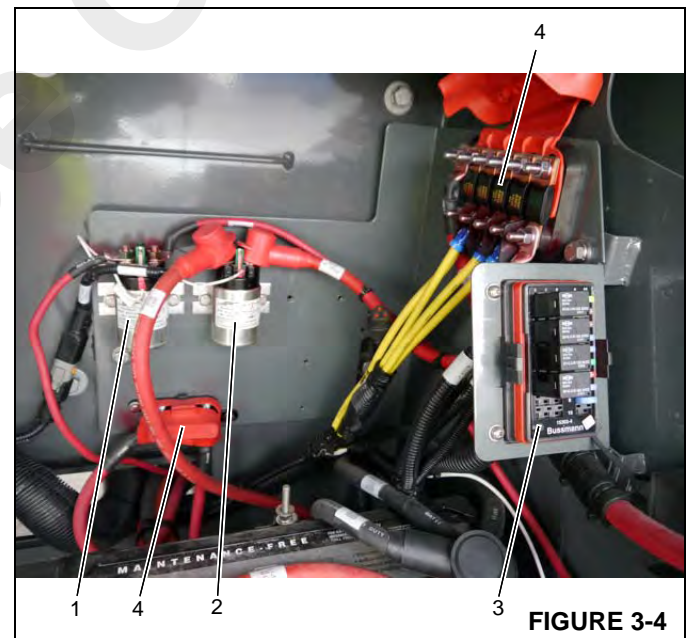

FIGURE 3-4

MAINTENANCE

General

Electrical system maintenance includes troubleshooting and replacement of damaged components. Observe standard wiring practices when replacing components.



CAUTION

If it is necessary to perform electrical maintenance on live or hot circuits, remove all rings, watches, and other jewelry before performing maintenance as serious burns result from accidental grounding or shorting circuits.

CAUTION

Ensure the batteries are disconnected before performing any maintenance on an electrical circuit which is not fused or when performing continuity checks.

Never replace original wiring with wiring of a smaller size (gauge).

General Troubleshooting



CAUTION

Many steps in the troubleshooting procedures require testing live (energized) components. Perform these steps observing good safety practices to avoid electrical shock injury.

NOTE: Make voltage checks at terminations when components are installed and operating. Make continuity checks (with batteries disconnected) when components are isolated or removed. Troubleshoot per the following guidelines:

1. First, use reported symptoms to identify a problem or a suspect component.
2. Test the suspect component per instructions in this section. The instructions identify the circuit breakers and components and guide you from the easiest and most likely problems to the hardest and least likely problems.
3. Using a multimeter, test the circuit for continuity if you suspect a broken circuit or for voltage if you suspect a power problem. Check the electrical schematic and wiring diagram for most accurate wiring information.
4. If the component proves faulty, replace it with a known working component.

5. If wiring proves faulty, this is typically the result of another failure within the electrical system. Identify and investigate the root cause of failure. Make necessary component repairs as outlined in the following sections. Proceed to make appropriate wiring fault repair. Wiring repairs must be made using Manitowoc approved materials.
6. Splicing sections of broken wire must have terminations that meet minimum pull test requirements listed in table 3-5. Splices must be completely covered with adhesive lined shrink tubing. Tubing must extend beyond any bar conductors by at least ¼”.

Table 3-5 Minimum Pull Values (In lbs)

Wire Gauge	Single Wire	Two Wire Termination
24	10	8
22	15	10
20	20	17
18	30	20
16	40	30
14	60	50
12	70	60
10	80	70
8	90	80
6	100	90
4	140	120

7. After troubleshooting, test the repaired harness. Verify the circuit works properly.

Troubleshooting Swivel-Caused Electrical Problems

Troubles common to the swivel are improper mounting, foreign material between the brushes and slip rings, incorrect wiring from the swivel to the components, incorrect wire size, worn brushes, improper spring tension on the brush assembly, and loose setscrews on the slip ring assembly. Refer to the electrical schematic and wiring diagram for slip ring connections and amperages.

Connector Troubleshooting

The cause of an electrical problem may be a loose or corroded connection in the pin or socket connectors. Check the connectors to ensure that the pins and sockets are properly seated and engaged. If the pins and sockets show any signs of corrosion, use a good quality electrical contact cleaner or fine sandpaper to clean them. When the pins or sockets show signs of arcing or burning, it indicates another failure within the electrical system that might cause the condition. Identify and investigate the root cause of the failure, make necessary component repairs and then proceed to make the necessary wire terminal repairs.

When replacing wire terminals, use the proper crimp tool to ensure the proper crimping method. Refer to the tables at the end of this section listing tools necessary for connector maintenance. These tables list common tools; however, contact Manitowoc CraneCare to ensure the proper crimp tool is available.

Because the pins and sockets are crimped to the wires, it is not possible to remove them. Using the proper extraction tool, remove the pin(s) or socket(s) from the plug or receptacle. Cut the wire as close to the pin or socket as possible. After cutting the pin or socket off, the wire will most likely be too short. Using a wire that is too short will allow pressure to be applied to the pin or socket and wire where they are crimped when the pin or socket is inserted in the plug or receptacle. Splice a short length of wire to the short wire according to the guidelines in the General Troubleshooting section.

Troubleshooting Engine Starting Problems

1. Verify the battery terminals are connected and clean, none of the fuses are blown, the transmission is in neutral, and the machine is fueled.
2. Try to turn on the head lights, tails lights, marker lights, dome light, work light, or gauge lights and panel lights to verify the battery has at least some charge. If none of these lights comes on, suspect the battery. Charge battery as needed, jump-start the crane or replace the battery when possible.

NOTE: The crane is a 24V machine which requires a 24V source for jump starting.

3. If you hear the starter relay clicking repeatedly, power is reaching the starter, but not enough; suspect the battery. Charge battery as needed, jump-start the crane or replace the battery when possible.
4. If the problem remains, troubleshoot the starter lockout relay. Use service tool for starter lockout input signal to CCM11. Also, check starter lockout relay to ensure it is energized.
5. Using the service tool (see "Using Service Tool Section"), check for proper Keyswitch input signals and Start output signals. With the Service Tool connected to the crane A channel, Select View, Cab, Steering Column. Watch the Keystate value for each position of the Keyswitch:

0=OFF

1=ON

2=START

6. If the battery, fuses, secondary circuit, ignition switch, and power circuit to the ignition switch check out, do one of the following:

- a. If you hear no noise when you try to turn the starter, troubleshoot the start circuit (ignition switch, electric shifter, and wiring from ignition switch to starter relay). Make repairs as needed.
- b. If the engine still won't start, and you hear no noise or just a single click, suspect the starter. Troubleshoot the starter circuit from the starter relay through the starter solenoid to the starter motor and ground. Make repairs as needed. If the starter solenoid or the starter motor is faulty, replace the starter.
- c. If the starter engages but can't turn the engine (and the lights dim, signaling power drain during start attempt), check the starter's feed circuit from the batteries for resistance. If the resistance is high, greater than $.002\Omega$, make repairs. If the circuit checks out, replace the starter. If the engine still won't start, suspect a seized engine.
- d. If the starter turns the engine, but it still won't start, suspect a fuel problem. Ensure fuel system can draw fuel from the tank and pump it to the engine; make repairs as needed.
- e. If the engine starts, then shuts down, suspect a fuel problem. Ensure fuel system can draw fuel from the tank and pump it to the engine; make repairs as needed.

7. Refer to the engine manual for further instructions.

NOTE: If the starter won't disengage during running, verify the starter is mounted properly so its gear won't mesh with the engine's flywheel when not trying to start engine. Troubleshoot the starter relay and ignition switch for closed contacts. If these components check out, replace the starter.

Troubleshooting Engine Charging Problems

1. Verify battery terminals are connected and clean and all wires in the charging system are in good repair and are connected properly.
2. Verify the alternator belt is properly installed and is under proper tension.
3. Verify the battery puts out 24 volts minimum. Charge battery as needed so the battery can supply a minimum excitation voltage to the engine's charging system.
4. Verify when the crane is running that the alternator is putting out a minimum of 24 volts DC on the voltmeter.
5. Replace the alternator if the other conditions check out.
6. Refer to the engine manual for further instructions.

NOTE: If the alternator runs noisily, check belt tension. If problem persists, replace alternator.

NOTE: If the alternator overcharges (voltmeter reads high, light bulbs burn out quickly), look for a ground where one shouldn't exist. If external wiring checks out, replace alternator.

Troubleshooting Accessories

If the crane's engine starts and charges properly, but none of its components except the horn or lights work, the accessory circuitry may be faulty. Check as follows:

1. Turn the ignition switch to ON (Position 1). Try to turn on the cab circulating fan, the heater fan, the defroster fan, or the windshield wipers or washer. If none of these come on (but the head lights, tail lights, marker lights, dome light or work light will come on), there is accessory circuitry problem.
2. Check the primary power circuit to the accessory relay K101 in the Cab fuse & relay panel. Make circuit repairs as needed.
3. If the problem remains, check the ignition switch and the accessory control circuit from the ignition switch through the coil of the accessory relay (KS1) to ground. Turn the ignition switch to ON (Position 1) and shift the electric shifter to reverse; if the backup lights and backup alarm do not turn on, then there is no power through the switch when it is on (Position 1). Replace ignition switch if there is no power through it when it is ON (Position 1). Replace accessory relay if there is no continuity through its coil. Make circuit repairs to accessory control circuit as needed.
4. If the problem remains, check the accessory relay (K101) contacts and the accessory power circuit. Replace relay if its contacts stay open when the coil is energized. Make circuit repairs as needed.

Alternator Replacement

Removal

1. Ensure that the key switch has been in the OFF position for 2 minutes.
2. Turn the battery disconnect switch to the OFF position.
3. Remove the ECM power fuse.
4. Remove and isolate the negative battery cables.
5. Open the engine compartment.
6. Tag and disconnect the electrical leads from the terminals on the alternator.
7. Turn the tensioner below the alternator clockwise to remove tension from the belt. Slip the belt off of the alternator pulley, then let the tensioner return to its normal position.
8. Remove and tag all wires. Remove the alternator link capscrew and the mounting capscrew. Remove the alternator.

Installation

1. Inspect the belt. Verify it has no cracks or other damage. Replace damaged belt as needed.
2. To assemble the alternator, the mounting components must be tightened in the following sequence.
 - a. Alternator-to-alternator bracket capscrew.
 - b. Lower brace-to-alternator capscrew.
 - c. Lower alternator brace-to-water pump capscrew.
 - d. Torque brace-to-alternator bolt, see Fasteners and Torque Values (pg 1-11). Torque alternator-to-alternator bracket, see Fasteners and Torque Values (pg 1-11).
3. Install the belt on all engine pulleys except the alternator pulley for now.
4. Turn the tensioner clockwise. Slip the belt onto the alternator pulley, then carefully return the tensioner to its normal position so it puts tension on the belt. Make sure the belt is centered on the tensioner.
5. Check belt tension at the belt's longest span (longest distance between pulleys). At the center point of the longest span, push in on the belt with your thumb. Verify you can deflect the belt no more than 10 to 13 mm (3/8 to 1/2 inch) with your thumb. (Or, using a belt tension gauge, verify there is 267 to 578 N (60 to 130 lb) of tension on the belt in the middle of its longest span.) Replace belt if it is too loose (overstretched).
6. Verify tensioner bolt is torqued to 43 Nm (32 lb-ft).

7. Connect the electrical leads to the terminals as tagged during removal.
8. Close the engine compartment.
9. Reconnect the ground cables to the battery.
10. Install the ECM power fuse.
11. Turn the battery disconnect switch to the ON position.

Check

1. Run engine. Verify reading of voltmeter on front console is 24 volts or greater. Make repairs as needed.
2. Continue troubleshooting charging system as needed if replacement of alternator did not correct problem in charging system.

Starter Replacement

Removal

1. Ensure that the key switch has been in the OFF position for 2 minutes.
2. Turn the battery disconnect switch to the OFF position.
3. Remove the ECM power fuse.
4. Remove and isolate the negative battery cables.
5. Open the engine compartment.
6. Tag and disconnect the electrical leads from the terminals on the starter.
7. Remove the bolts holding the starter to the mounting pad. Remove the starter.

Installation

1. Place the starter on its mounting pad. Secure the starter with the bolts. Torque the bolts to 43 Nm (32 lb-ft).
2. Connect the electrical leads to the terminals as tagged during removal.
3. Connect the batteries.
4. Install the ECM power fuse.
5. Turn the battery disconnect switch to the ON position.
6. Close the engine compartment.

Check

1. Try to start the engine. Verify the starter starts the engine.
2. Start engine again, and listen for starter noises. Verify there is no abnormal noise indicating the starter's gear is meshing improperly with the flywheel, that the starter's gear hasn't disengaged from the flywheel after the ignition switch is in the ignition (run) position, or some other problem. Install starter properly as needed.

Battery Replacement

Removal

CAUTION

To avoid possible engine fault codes and undesirable operation, ensure the keyswitch has been off 2 minutes before disconnecting batteries.

Disconnect batteries, if machine will be inactive for over 24 hours.

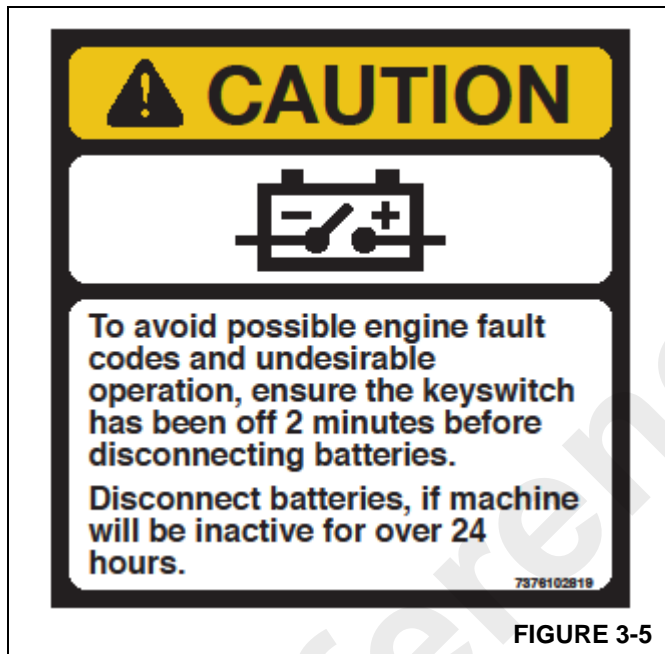

FIGURE 3-5

1. Ensure that the key switch has been in the OFF position for 2 minutes.
2. Turn the battery disconnect switch to the OFF position.
3. Remove the ECM power fuse.
4. Remove the negative battery cables.
5. Remove the positive battery cables.
6. Tag and disconnect leads from the battery terminals starting with the positive terminals.
7. Remove the nuts and washers from the bracket hold down rods. Remove the hold down bracket.
8. Remove the batteries.

Installation

1. Place the batteries in the battery box.
2. Install the hold down brackets so they can hold down the batteries. Secure the brackets (and batteries) to the bracket hold down rods with nuts and washers.
3. Connect leads to the battery terminals starting with the negative terminals (Figure 3-5)
4. Install the ECM power fuse.
5. Close the battery box cover.
6. Turn the battery disconnect switch to ON.
7. Verify replacement batteries work by starting crane's engine and operating various crane components.

Relay Panel Component Replacement

Accessory Relay

1. Ensure that the key switch has been in the OFF position for 2 minutes.
2. Turn the battery disconnect switch to the OFF position.
3. Remove the hardware securing the console front cover and remove the cover.
4. Tag and disconnect the electrical leads from the suspect relay.
5. Remove the hardware securing the suspect relay to the relay panel assembly. Remove suspect relay.
6. Install replacement relay on relay panel and secure it with attaching hardware.
7. Connect the electrical leads to the relay as tagged during removal.
8. Position the console front cover on the console and secure with the attaching hardware.
9. Connect the batteries.
10. Turn the battery disconnect switch to the ON position.
11. Verify proper installation by operating all components involved with the replacement relay verifying they all work.

Rocker Switch Replacement

Use the following procedures and refer to Figure 3-6 when removing/installing a switch.

Removal

1. Ensure that the key switch has been in the OFF position for 2 minutes.
2. Turn the battery disconnect switch to the OFF position.

3. Pull the rubber boot (11) off the bottom of the left and right side covers (8, 9).
4. Remove the lever (12) and spacer that locks/unlocks the steering column tilt/telescope function.
5. Remove the four screws (13) securing the left and right side covers (8, 9) together.
6. Remove the six screws (14) securing the left and right side covers (8, 9) to the gauge/switch cover (6).
7. Remove the left side cover (8) from the steering column.
8. Disconnect the wire harness from the back of the ignition switch (10).
9. Remove the right side cover (9) from the steering column.
10. Disconnect the wire harness from the bottom of the switch (4) that must be replaced. Remove the switch by squeezing the retaining clips on each side of switch and pushing upwards until switch is free of cover.
4. Connect the wire harness to the bottom of the switch (4).
5. Install the right side cover (9) on the steering column.
6. Connect the wire harness to the ignition switch (10).
7. Install the left side cover (8) on the steering column.
8. Secure the gauge/switch cover (6) to the left and right side covers (8, 9) using six screws (14).
9. Secure the left and right side covers (8, 9) together using four screws (13).
10. Install the lever (12) and spacer that locks/unlocks the steering column tilt/telescope function.
11. Pull the rubber boot (11) up and over the bottom of the left and right side covers (8, 9).
12. Turn the battery disconnect switch to the ON position.

Check

1. Operate the switch per the Operator Manual. Verify each of its functions works.
2. As needed, troubleshoot further any system or circuit malfunction not corrected by repair or replacement of the switch or associated wiring.

Inspection

1. Visually check the switch for evidence of cracks, damaged connections, or other damage. Replace damaged switch as needed.
2. Check wiring for damaged insulation or damaged connectors. Repair as needed.
3. Check all connectors for corrosion. Replace corroded components as needed.
4. Perform the following check to determine switch serviceability.
 - a. Using an ohmmeter, check for continuity between the switch terminals with switch at ON or activated position(s). Ohmmeter should register zero ohms (continuity).
 - b. Place switch at OFF or deactivated position. Ohmmeter should register infinity (no continuity).
 - c. Replace switch if it fails either part of the check.

Installation

1. Remove the rocker (3) from the old switch by holding the switch by its sides in one hand and then squeezing the left and right sides of the rocker with the other hand and pulling up.
2. Orient the rocker (3) correctly relative to the new switch (4), then install rocker in switch.
3. Install the switch (4) in the gauge/switch cover (6) by pushing the switch (4) down through the top of the gauge/switch cover (6) until the switch's retaining clips click in place.

Ignition Switch Replacement

Use the following procedures and refer to Figure 3-6 when removing/installing the ignition switch.

Removal

1. Ensure that the key switch has been in the OFF position for 2 minutes.
2. Turn the battery disconnect switch to the OFF position.
3. Pull the rubber boot (11) off the bottom of the left and right side covers (8, 9).
4. Remove the lever (12) and spacer that locks/unlocks the steering column tilt/telescope function.
5. Remove the four screws (13) securing the left and right side covers (8, 9) together.
6. Remove the six screws (14) securing the left and right side covers (8, 9) to the gauge/switch cover (6).
7. Remove the left side cover (8) from the steering column.
8. Disconnect the wire harness from the back of the ignition switch (10).
9. Remove the right side cover (9) from the steering column.
10. Remove the locking nut that secures the ignition switch (10) to the right cover (9) and remove the ignition switch (10).

Inspection

1. Visually check the ignition switch for evidence of cracks, damaged connections, or other damage. Replace damaged ignition switch as needed.
2. Check wiring for damaged insulation or damaged connectors. Repair as needed.
3. Check all connectors for corrosion. Replace corroded components as needed.
4. Perform the following check to determine ignition switch serviceability.
 - a. Using an ohmmeter, check for continuity between the switch terminals with switch at ON or activated position(s). Ohmmeter should register zero ohms (continuity).
 - b. Place switch at OFF or deactivated position. Ohmmeter should register infinity (no continuity).
 - c. Replace switch if it fails either part of the check.

Installation

1. Install the ignition switch (10) in the right side cover (9) and secure with the locking nut.
2. Install the right side cover (9) on the steering column.
3. Connect the wire harness to the ignition switch (10).
4. Install the left side cover (8) on the steering column.
5. Secure the gauge/switch cover (6) to the left and right side covers (8, 9) using six screws (14).
6. Secure the left and right side covers (8, 9) together using four screws (13).
7. Install the lever (12) and spacer that locks/unlocks the steering column tilt/telescope function.
8. Pull the rubber boot (11) up and over the bottom of the left and right side covers (8, 9).
9. Turn the battery disconnect switch to the ON position.

Check

1. Operate the ignition switch per the Operator Manual. Verify each of its functions works.
2. As needed, troubleshoot further any system or circuit malfunction not corrected by repair or replacement of the switch or associated wiring.

Turn Signal Lever and Transmission Shift Lever Replacement

Use the following procedures and refer to Figure 3-6 when removing/installing the turn signal lever or transmission shift lever.

Removal

1. Ensure that the key switch has been in the OFF position for 2 minutes.
2. Turn the battery disconnect switch to the OFF position.
3. Pull the rubber boot (11) off the bottom of the left and right side covers (8, 9).
4. Remove the lever (12) and spacer that locks/unlocks the steering column tilt/telescope function.
5. Remove the steering wheel by doing the following:
 - a. Remove the steering wheel cap (1) using a twisting motion by pushing on the side of the cap closest to you with your thumbs while simultaneously pulling on the side of the cap farthest from you with your fingers.
 - b. Remove the securing nut from the steering column shaft and remove the steering wheel (2).
6. Remove the four screws (13) securing the left and right side covers (8, 9) together.
7. Remove the six screws (14) securing the left and right side covers (8, 9) to the gauge/switch cover (6).
8. Remove the left side cover (8) from the steering column.
9. Disconnect the wire harness from the back of the ignition switch (10).
10. Remove the right side cover (9) from the steering column.
11. Disconnect the wire harness from the bottom of the gauge cluster (5).
12. Tag and disconnect the wire harness from the bottom of each switch (4).
13. Remove the gauge/switch cover (6) from the steering column.
14. Disconnect the wire harnesses from the bottom of the turn signal and transmission shift levers (7).
15. Remove the two bolts and nuts securing the two levers (7) together.

Installation

1. Align the location pins of the turn signal and transmission shift levers (7) with the holes in the steering column.
2. Secure the two levers (7) together using the two bolts and nuts.
3. Connect the wire harnesses to the levers (7).
4. Install the gauge/switch cover (6) on the steering column.

5. Connect the wire harness to the bottom of the gauge cluster (5).
6. Install the wire harnesses on the switches (4) as tagged during removal.
7. Install the right side cover (9) on the steering column.
8. Connect the wire harness to the ignition switch (10).
9. Install the left side cover (8) on the steering column.
10. Secure the gauge/switch cover (6) to the left and right side covers (8, 9) using six screws (14).
11. Secure the left and right side covers (8, 9) together using four screws (13).
12. Install the steering wheel (2); torque the securing nut to 30 lb-ft ±4 (40 Nm ±5).

13. Install the steering wheel cap (1).
14. Install the lever (12) and spacer that locks/unlocks the steering column tilt/telescope function.
15. Pull the rubber boot (11) up and over the bottom of the left and right side covers (8, 9).
16. Turn the battery disconnect switch to the ON position.

Check

1. Operate the turn signal lever or transmission shift lever per the Operator Manual. Verify each of its functions work.
2. As needed, troubleshoot further any system or circuit malfunction not corrected by repair or replacement of the switch or associated wiring.

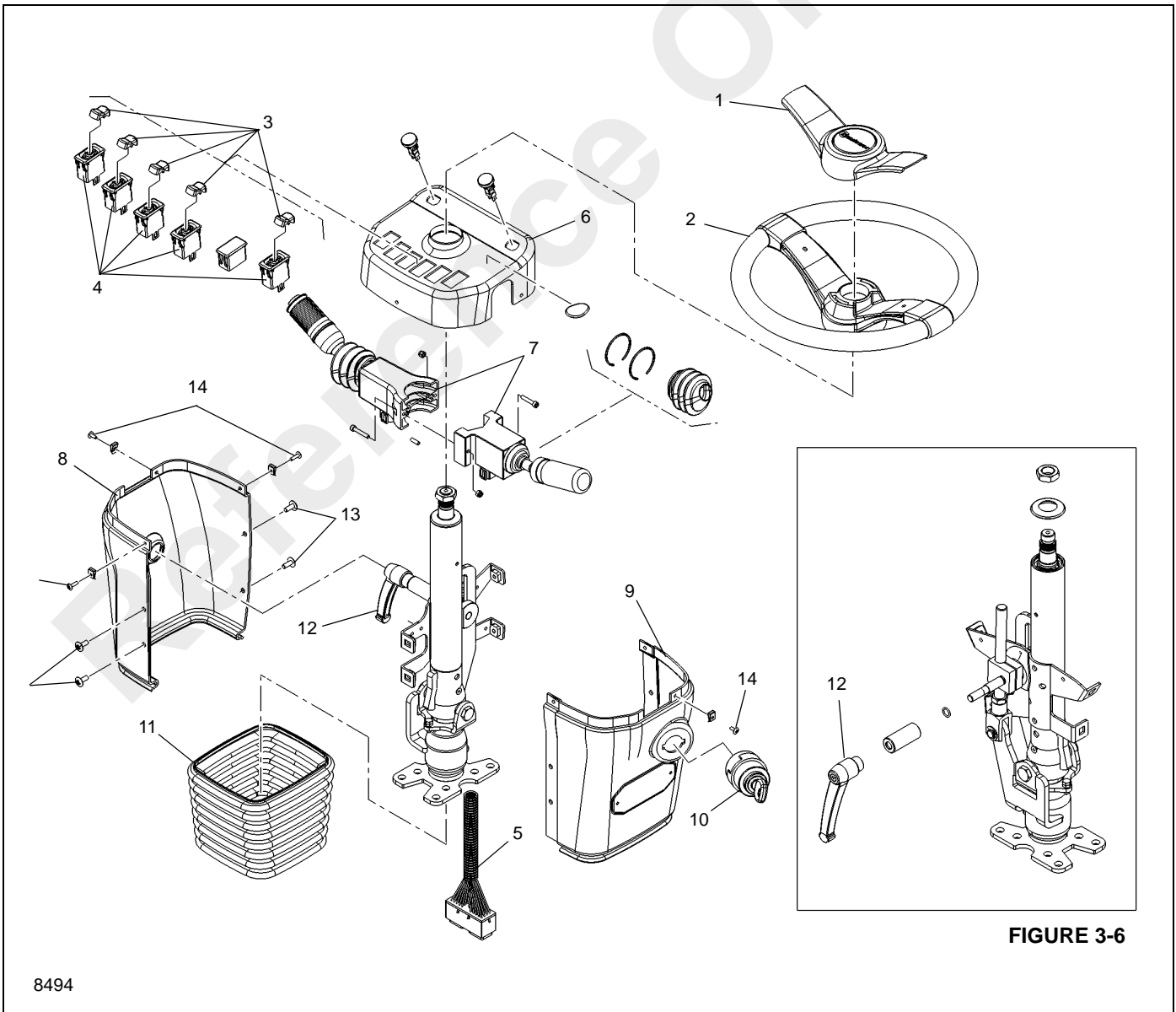

FIGURE 3-6

8494

Windshield Wiper Assembly Replacement

Removal

1. Ensure that the key switch has been in the OFF position for 2 minutes.
 2. Turn the battery disconnect switch to the OFF position.
 3. Tag and disconnect the electrical leads from the motor.
 4. Disconnect the washer hose on the wiper arm (also called the pantograph arm assembly) from the washer nozzle fitting assembly.
 5. Remove the cap nut and washer securing the wiper arm to the pantograph adapter kit. (The nut and washer are part of the pantograph adapter kit.) Remove the cap nut, washer, and tapered sleeve securing the wiper arm to the pivot shaft kit. (The nut, washer, and sleeve are part of the pivot shaft kit.)
 6. Remove the wiper arm from the pantograph adapter kit and the pivot shaft kit.
 7. Remove the flanged sleeve, nut, and two flat washers from the pivot shaft kit. (The sleeve, nut, and washers are part of the pivot shaft kit.)
 8. Remove the two capscrews and lockwashers securing the pantograph adapter kit's adapter to the cab exterior. Remove the pantograph adapter kit's adapter and gasket.
 9. Remove attaching hardware to free the windshield wiper motor bracket from the cab interior. Remove the bracket, with motor and pivot shaft connected, from the cab.
- NOTE:** You may have to remove or move other parts to get the bracket and attached parts around the steering column. Take care not to damage any parts.
10. Remove the nut to free the wiper motor's shaft from the wiper motor kit crank. Remove the three screws and washers to free the wiper motor from its bracket. Remove the wiper motor from its bracket. Leave the other parts attached to the bracket for now.

Inspection

1. Visually check the motor housing for evidence of cracks or other damage. Check for excessive shaft end play indicating worn or damaged bearings. Replace motor if damaged.
2. Inspect the wiper blade for serviceability. Replace wiper blade when worn.
3. Inspect the wiper arm and parts of the linking component kits (pantograph adapter kit, pivot shaft kit, wiper motor kit link and crank, wiper motor bracket) for damage. Replace as needed.

Installation

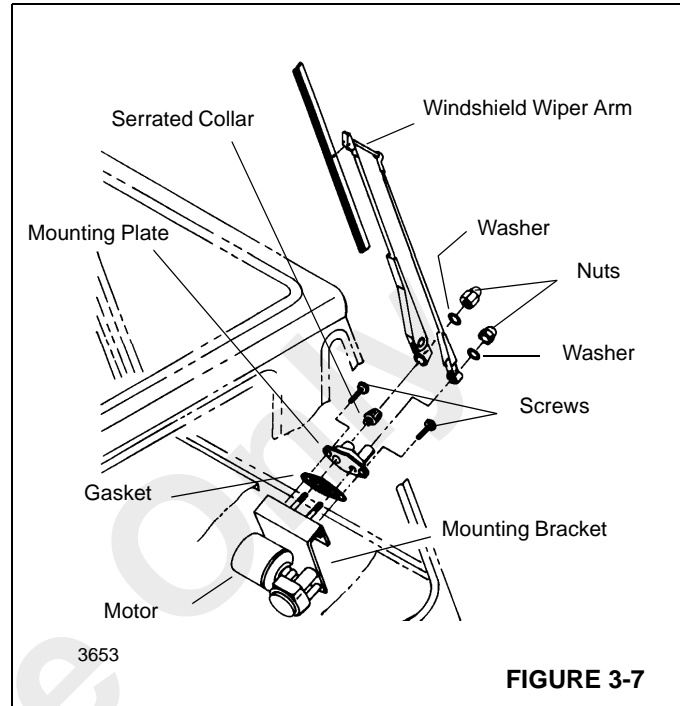

FIGURE 3-7

1. Verify the pivot shaft and the wiper motor kit link and crank are in place on the motor bracket. (Washers and clip springs fasten the link to the pivot pins on the crank and the pivot shaft. The pivot shaft's pivot pin mounts in the hole nearest the end of the pivot shaft's lever.)
 2. Connect the wiper motor to the motor bracket with screws and washers. Connect the wiper motor's shaft to the wiper motor kit crank with the nut and washer.
 3. Secure the adapter and the gasket of the pantograph adapter kit to the cab exterior with capscrews and lockwashers.
 4. Install the motor bracket and attached parts in the cab interior with attaching hardware. Ensure the pivot shaft sticks through the hole in the pantograph adapter kit.
- NOTE:** Take care not to damage any parts while moving the bracket and attached parts around the steering column.
5. Secure the pivot shaft to the pantograph adapter with the pivot shaft kit's nut and washers. Install the flanged sleeve on the pivot shaft.
 6. Install the wiper arm on the shafts of the pantograph adapter kit and the pivot shaft kit. Secure the wiper arm to the pantograph adapter kit shaft with the kit's own washer and cap nut. Secure the wiper arm to the pivot shaft with the pivot shaft kit's own tapered sleeve, washer, and cap nut.
 7. Connect the wiper arm's washer hose to the washer nozzle fitting assembly.

8. Connect the electrical leads to the wiper motor as marked before removal.
9. Turn the battery disconnect switch to the ON position.

Check

1. Squirt some cleaning fluid onto the windshield with the windshield washer.
2. Operate the windshield wiper. Verify it works. (Replace wiper blade as needed if it streaks or otherwise wipes poorly.)

Windshield Washer Assembly Replacement

Removal

1. Ensure that the key switch has been in the OFF position for 2 minutes.
2. Turn the battery disconnect switch to the OFF position.
3. Locate the windshield washer container and pump on the left rear side of the cab.
4. Tag and disconnect the pump's electrical lead and ground wire.
5. Disconnect the hose from the windshield washer pump. Point it so it won't spill cleaning fluid. Catch cleaning fluid from the windshield washer container with a suitable container.
6. Remove four self tapping screws securing the windshield washer container to the cab. Remove the windshield washer container and pump.
7. Remove pump and pump seal from container.

Inspection

1. Visually check the pump for evidence of cracks, leaks, or other damage. Replace pump if damaged.
2. Inspect the container for leaking. Replace pump seal if it is leaking. Replace container if it is damaged and leaking.
3. Inspect spray nozzle on the wiper arm. As needed, clean the nozzle with a fine piece of wire and compressed air.

Installation

1. Install pump and pump seal on container.
2. Install windshield washer container on the cab. Secure the container with four self tapping screws.
3. Attach the hose to the windshield washer pump.
4. Connect the pump's electrical lead and ground wire as tagged during removal.

5. Turn the battery disconnect switch to the ON position.
6. Fill the container with cleaning fluid.

Check

1. Squirt some cleaning fluid onto the windshield with the windshield washer.
2. Make repairs if windshield washer doesn't work.

Skylight Wiper Assembly Replacement

Removal

1. Ensure that the key switch has been in the OFF position for 2 minutes.
2. Turn the battery disconnect switch to the OFF position.
3. Tag and disconnect the electrical leads from the motor.
4. Remove the wiper arm from the motor shaft.
5. Remove the nut, spacer, leather washer, and nylon flat washer from the motor shaft outside the cab roof.
6. Remove the nut and lockwasher securing the motor bracket to the cab roof and remove the motor from the cab roof. Remove large nylon flat washer from motor shaft and flat washer and smaller nylon flat washer from mounting screw.
7. Remove mounting screw and nylon flat washer from outside cab roof.
8. Clean any sealing material from around holes in cab roof.

Inspection

1. Visually check the motor housing for evidence of cracks or other damage. Check for excessive shaft end play indicating worn or damaged bearings. Replace motor if damaged.
2. Inspect the wiper blade for serviceability. Replace wiper blade when worn.
3. Inspect the wiper arm and parts for damage. Replace as needed.

Installation

1. Install sealant material around both holes in cab roof, both inside and outside.
2. Install screw with nylon flat washer (from outside) through mounting hole in cab roof.
3. Install flat nylon washer on motor shaft and insert motor shaft through hole in cab roof. Position small nylon washer and flat washer on screw between mounting bracket and cab roof. Secure with lockwasher and nut.

4. Install nylon flat washer, leather washer, spacer, and nut on motor shaft. Tighten nut.
5. Install wiper arm and blade on motor shaft.
6. Connect the electrical leads to the wiper motor as marked before removal.
7. Turn the battery disconnect switch to the ON position.

Check

1. Operate the skylight wiper. Verify it works. (Replace wiper blade as needed if it streaks or otherwise wipes poorly.)

Reference Only

Table 3-6
Amp Extraction Tool Table

Description	Amp Part Number	Grove Part Number
14 gauge wire (connectors)	305183	9-999-100176
12 to 8 gauge wire (connectors)	91019-3	9-999-100175
4 to 9 circuit (in-line connectors)	453300-1	N/A
15 circuit (in-line connectors)	458944-1	N/A

Table 3-7
Amp Crimping Tool Table

Description	Amp Part Number		Grove Part Number	
	Tool	Die	Tool	Die
14 to 12 gauge wire	69710-1	90145-1	9-999-100177	N/A
10 to 8 gauge wire	69710-1	90140-1	9-999-100177	9-999-100178
4 to 9 circuit (in-line connectors)	69710-1	90306-1	9-999-100177	N/A
15 circuit (in-line connectors)	90299-1	--	N/A	--

Table 3-8
Deutsch Extraction Tool Table

Description	Deutsch Part Number	Grove Part Number
12 gauge wire	114010	9-999-100194
16 gauge wire	0411-204-1605	9-999-100195
8-10 gauge wire	114008	7-902-000012
4-6 gauge wire	114009	7-902-000009

Table 3-9
Deutsch Crimping Tool Table

Description	Deutsch Part Number	Grove Part Number
12, 14, 16, 18, 20 gauge wire	HDT-48-00	9-999-100808
4, 6, 8, 10 gauge wire	HDT04-08	9-999-100842

Appendix A: Crane Control System (CCS) Fault Codes

There are four codes for every fault in the Crane Control System (CCS) diagnostic. The Component Code number informs the operator which component is in fault mode; the Condition Code explains the actual malfunction; the Device Code indicates which module contains the fault; and the

Index Code reveals the type of fault. For example, a code reading "7111. 2. 0. 129" correlates to "RCL Display", "Cable Break", "SCMO", "CANbus 1". This means the RCL display CANbus cable to the SCMO module is broken.

Component Codes

Fault Code	Component Description
5000	Key switch On input
5001	Key switch Accessory input
5002	Key switch Start input
5003	Horn switch input
5005	Transmission Forward input
5006	Transmission Neutral input
5007	Transmission Reverse input
5008	Transmission 1st gear input
5009	Transmission 2nd gear input
5010	Transmission 3rd gear input
5011	Transmission 4th gear input
5012	Transmission 5th gear input
5013	Transmission speed gears (all)
5014	Transmission direction gears (all)
5015	Turn Signal left input
5016	Turn Signal right input
5017	Headlights input
5018	Marker lights input
5019	Hazard lights input
5020	Parking light switch
5021	Fog tail light switch
5022	Fog light switch
5023	Low beam headlight switch
5024	High beam headlight switch
5025	Windshield wiper low speed input
5026	Windshield wiper high speed input
5027	Windshield washer spray input
5028	Windshield wiper intermittent input
5030	Engine speed increment switch input
5031	Engine speed decrement switch input
5032	Rear steer left switch input

Fault Code	Component Description
5033	Rear steer right switch input
5034	Park brake release switch input
5035	2 wheel drive switch input
5036	Differential lock switch input
5037	Brake pedal switch input
5038	Retarder / Thelma brake switch
5040	Outrigger extend switch input
5041	Outrigger retract switch input
5042	Cabin lower switch input
5043	Cabin raise switch input
5050	Crane functions switch input
5051	Boom lights switch input
5052	Bypass hoist limiter switch input
5053	Bypass RCL inside switch input
5054	Bypass RCL outside switch input
5055	Bypass Derricking switch input
5056	Aircraft warning light switch input
5057	Working light switch input
5058	Rotating flashing light switch
5059	High beam flasher switch
5060	Air Condition Switch (Carrier)
5061	Air Condition Switch (Superstructure)
5100	Enable Extend switch input
5101	Enable Retract switch input
5102	Enable Aux Hoist switch input
5103	Enable Main Hoist switch input
5104	Enable Derricking switch input
5105	Enable Slewing switch input
5106	Enable Telescoping switch input
5107	Enable Freeswing switch input
5108	Enable Jib switch input
5109	Jib Identity
5110	Jib Remote Control down switch input
5111	Jib Remote Control up switch input
5112	Cab Tilt Down switch input
5113	Cab Tilt Up switch input
5150	Left Joystick Deadman input
5151	Right Joystick Deadman input

Fault Code	Component Description
5152	Seat Switch deadman input
5153	Armrest deadman switch input
5154	Both Deadman switches input
5160	Carrier Emergency Off Switch
5161	Carrier Emergency Off Relay input
5162	Carrier Emergency Operation input
5163	AMOT active input
5170	Exhaust System Cleaning Init switch input
5171	Exhaust System Cleaning Inhibit switch input
5300	Gas Pedal PWM input
5301	Slew Brake Pedal PWM input
5302	Telescoping Pedal PWM input
5303	Gas Pedal ANA input
5304	Service brake pedal ANA input
5305	Slewing brake pedal ANA input
5500	Cold Weather switch input
5501	Rear Wheels Not Centered switch input
5502	Differential Lock Front switch input
5503	Differential Lock Rear switch input
5504	Oil Temperature switch input
5505	Hydraulic oil temperature switch input
5506	Slewing system temperature switch input
5507	Starter Lockout
5509	All wheel drive active input switch
5510	Axle locking input switch
5511	Cross Diff Lock switch input Axle 1
5512	Cross Diff Lock switch input Axle 2
5513	Cross Diff Lock switch input Axle 3
5514	Cross Diff Lock switch input Axle 4
5515	Cross Diff Lock switch input Axle 5
5516	Cross Diff Lock switch input Axle 6
5517	Cross Diff Lock switch input Axle 7
5518	Cross Diff Lock switch input Axle 8
5519	Cross Diff Lock switch input Axle 9
5522	Long Diff Lock switch input Axle 2
5523	Long Diff Lock switch input Axle 3
5524	Long Diff Lock switch input Axle 4
5525	Long Diff Lock switch input Axle 5

Fault Code	Component Description
5526	Long Diff Lock switch input Axle 6
5527	Long Diff Lock switch input Axle 7
5528	Long Diff Lock switch input Axle 8
5529	Long Diff Lock switch input Axle 9
5530	Drag link unlocked
5531	Drag link locked
5533	Steering Rod Lock switch input Axle 3
5534	Steering Rod Lock switch input Axle 4
5535	Steering Rod Lock switch input Axle 5
5536	Steering Rod Lock switch input Axle 6
5537	Steering Rod Lock switch input Axle 7
5538	Steering Rod Lock switch input Axle 8
5539	Steering Rod Lock switch input Axle 9
5600	Park Brake Pressure switch input
5601	ABS Trolley input
5602	Suspension group too high (front left) input
5603	Suspension group too high (front right) input
5604	Suspension group too high (rear left) input
5605	Suspension group too high (rear right) input
5606	Suspension group too low (front left) input
5607	Suspension group too low (front right) input
5608	Suspension group too low (rear left) input
5609	Suspension group too low (rear right) input
5700	Cab Sensor for Humidity
5800	Outrigger length left front analog input
5801	Outrigger length left rear analog input
5802	Outrigger length right front analog input
5803	Outrigger length right rear analog input
5804	Hoist limiter analog input
5805	Telescoping cylinder length analog input
5806	Stabilizer pressure sensor input, front left
5807	Stabilizer pressure sensor input, rear left
5808	Stabilizer pressure sensor input, front right
5809	Stabilizer pressure sensor input, rear right
5810	Anemometer analog input
5811	Angle sensor axle 1
5812	Angle sensor axle 2
5813	Angle sensor axle 3

Fault Code	Component Description
5814	Angle sensor axle 4
5815	Angle sensor axle 5
5816	Angle sensor axle 6
5817	Angle sensor axle 7
5818	Angle sensor axle 8
5819	Angle sensor axle 9
5820	Fuel Level analog input
5821	Sensor Supply Voltage analog input
5822	Pressure Sensor Axle 1 Left
5823	Pressure Sensor Axle 1 Right
5824	Pressure Sensor Axle 2-3 Left
5825	Pressure Sensor Axle 2-3 Right
5826	Pressure Sensor Axle 4-5 Left
5827	Pressure Sensor Axle 4-5 Right
5828	Pressure Sensor Axle 6-7 Left
5829	Pressure Sensor Axle 6-7 Right
5830	Pressure Sensor Axle 8-9 Left
5831	Pressure Sensor Axle 8-9 Right
5833	Cabin Temperature Sensor Head
5834	Cabin Temperature Sensor Feet
5835	Cabin Temperature Sensor Back
5836	Cabin Sensor Humidity
5840	Service Brake Circle 1
5841	Service Brake Circle 2
5845	Transmission Temperature
5850	LIM override simulated output
5900	Main Hoist Counter / encoder
5901	Main Hoist direction input
5902	Aux Hoist Counter / encoder
5903	Aux Hoist direction input
5904	Main hoist 3rd wrap input
5905	Aux hoist 3rd wrap input
5906	System Release input (signal from SCM0)
5907	Emergency Stop input
5908	Main Hoist Lower pressure switch
5909	Main Hoist Raise pressure switch
5910	Aux Hoist Lower pressure switch
5911	Aux Hoist Raise pressure switch

Fault Code	Component Description
5912	Derricking Down pressure switch
5913	Derricking Up pressure switch
5914	Telescoping Extend pressure switch
5915	Telescoping Retract pressure switch
5916	Hydraulic Oil Temp switch
5917	Brake Pressure switch
5918	AC Clutch Required switch
5919	Swing Right pressure switch
5920	Swing Left pressure switch
5921	Swing Brake pressure switch
5922	Hydraulic Oil Filter pressure switch
5923	Steering Pressure low switch
5924	Boom Section Locked redundant switch
5925	Left Tele Cylinder Locked redundant switch
5926	Right Tele Cylinder Locked redundant switch
5927	Left Tele Cylinder Pins Low switch
5928	Left Tele Cylinder Pins High switch
5929	Boom Section Locked switch
5930	Boom Section Unlocked switch
5931	Left Tele Cylinder Pin Unlocked switch
5932	Right Tele Cylinder Pin Unlocked switch
5933	Left Tele Cylinder Pin Locked switch
5934	Right Tele Cylinder Pin Locked switch
5935	Right Tele Cylinder Pins Low switch
5936	Right Tele Cylinder Pins High switch
5937	Jib mounted & folded switch
5938	Turntable Locked switch
5939	Turntable Unlocked switch
5940	Pump 1 Pressure analog input
5941	Telescoping Pressure analog input
5942	Slewing Pressure analog input
5943	Hoist Limiter (A2B) analog input
5944	Piston Length Sensor analog input
5945	8.5V External Feedback analog input
5946	Accumulator pressure sensor analog input
5947	Mechanical locking head TUSL switch
5948	Mechanical locking head TLSL switch
5949	Mechanical locking head TLSU switch

Fault Code	Component Description
5950	Auxiliary Hoist Identifier input
5951	New York House Lock Pin Bolted input
5952	New York House Lock Locked input
5953	New York House Lock Unlocked input
5954	Counterweight Left Unlock input
5955	Counterweight Right Unlock input
5956	Counterweight Left Lock input
5957	Counterweight Right Lock input
5958	Counterweight Left Bottom Proximity Switch input
5959	Counterweight Right Bottom Proximity Switch input
5960	Counterweight Left Top Proximity Switch input
5961	Counterweight Right Top Proximity Switch input
5962	Hoist Limiter (A2B) Switch input - Stop
5963	Steering Filter switch input
5964	Flow indicator steering circle 1
5965	Flow indicator steering circle 2
5966	Air Filter switch input
5967	Cabin locked left switch input
5968	Cabin locked right switch input
5969	Bridge collision switch input
5970	Filter backpressure switch input 1
5971	Filter backpressure switch input 2
5972	Length Hydraulic pivot cylinder
5973	Auxhoist right locked
5974	Auxhoist left locked
5975	Auxhoist right unlocked
5976	Auxhoist left unlocked
5977	Auxhoist carrier retracted
5978	Counterweight installed input
5979	Counterweight in position input
5980	Counterweight position left analog input
5981	Counterweight position right analog input
5982	Derricking valve spool position analog input
5983	Slew left pressure analog input
5984	Slew right pressure analog input
5985	Hoist Limiter (A2B) Switch input - Slow
6000	PERM 24V voltage output
6001	Release LMI output

Fault Code	Component Description
6002	Gearshift power supply output
6003	SCM0 ignition to CCM10 output
6004	SCM0 ignition to CCM11 output
6005	Oil Cooler Off relay output
6006	SCM0 ignition to IOS modules output
6007	SCM0 ignition to displays output
6008	Accessory output
6010	Turn signal left output
6011	Turn signal right output
6020	Left armrest lamps output
6021	Right armrest lamps output
6030	Perm VCC output
6031	Boom Lights 1 output
6032	Boom Lights 2 output
6033	IOL30 Sensor supply output
6034	Aircraft Warning Light output
6035	Horn output
6036	AC Condenser Motor output
6037	Windshield Washer output
6038	Beacon Lights output
6039	IOS20 Sensor Supply output
6040	Lamp Main hoist output
6041	Lamp Derricking output
6042	Lamp Telescoping output
6043	Lamp Jib output
6044	Lamp Park Brake output
6045	Lamp Slewing output
6046	Lamp Aux Hoist output
6047	Flight traffic light output
6048	Release hoist limiter
6049	IOL34 Sensor supply output
6050	New York House Lock change direction output
6051	New York House Lock release direction output
6060	Windshield Wash front Wiper
6061	Windshield Wash top Wiper
6062	Delay Front Wiper
6063	Delay Top Wiper
6064	Windshield Wash front Wiper low speed

Fault Code	Component Description
6065	Windshield Wash front Wiper high speed
6066	Windshield Wash front Wiper park
6100	Headlight Low Beam Left output
6101	Headlight Low Beam Right output
6102	Brake Lights output
6103	Engine Start output
6104	AC Clutch output
6105	Marker Lights output
6106	Reverse Lights output
6107	Derricking Release output
6108	Daytime Driving Light output
6109	Fuel Heater Relay output
6110	Enable Cross (Transverse) Differential Locks Output
6111	Enable Longitudinal Differential Locks Output
6112	Enable Axle Blocking Output
6113	Unlock Axle 3 Steering Output
6114	Unlock Axle 4 Steering Output
6115	Unlock Axle 5 Steering Output
6116	Unlock Axle 6 Steering Output
6117	Unlock Axle 7 Steering Output
6118	Unlock Axle 8 Steering Output
6119	Unlock Axle 9 Steering Output
6120	Superstructure Maneuvering Enable Output (EDM)
6121	Select Gear D Output (EDM)
6122	Select Gear N Output (EDM)
6123	Select Gear R Output (EDM)
6124	PTO Request Output (EDM)
6125	Inhibit Upshift Output (EDM)
6126	Inhibit Engine Start Output
6127	Switch carrier/super cabin
6128	Central lubrication
6130	Air Conditioning ON output
6131	Air Conditioning (Superstructure) output
6132	Air Conditioning (Carrier) output
6133	Retarder (Telma brake) output
6134	Fog tail lights output
6135	Fog lights output
6136	High beam headlight

Fault Code	Component Description
6137	Outrigger Light Front Left Output
6138	Outrigger Light Front Right Output
6139	Outrigger Light Rear Left Output
6140	Outrigger Light Rear Right Output
6200	Four Wheel Drive output
6201	Rear Axle Oscillation output
6202	Rear Steer Right output
6203	Rear Steer Left output
6204	Park Brake Release output
6205	Differential Lock output
6206	Load Sense output
6210	Stabilizer Left Front solenoid
6211	Stabilizer Right Front solenoid
6212	Stabilizer Left Rear solenoid
6213	Stabilizer Right Rear solenoid
6215	Beam Left Front solenoid
6216	Beam Right Front solenoid
6217	Beam Left Rear solenoid
6218	Beam Right Rear solenoid
6220	Outrigger Extend solenoid
6221	Outrigger Retract solenoid
6225	Transmission Forward solenoid
6226	Transmission Reverse solenoid
6227	Transmission First Gear solenoid
6228	Transmission Second Gear solenoid
6229	Transmission Third Gear solenoid
6230	Transmission Fourth Gear solenoid
6231	Transmission Fifth Gear solenoid
6240	Pressure buildup solenoid
6241	Release All Wheel steering solenoid
6244	Steering Control Valve 1 solenoid
6245	Steering Control Valve 2 solenoid
6246	Steering Control Valve 3 solenoid
6247	Slewing System Release solenoid
6248	Block Steering Circuit 1 solenoid
6249	Service Brake solenoid
6250	AMOT valve solenoid (Air intake valve)
6251	Steer Left solenoid Axle 1

Fault Code	Component Description
6252	Steer Left solenoid Axle 2
6253	Steer Left solenoid Axle 3
6254	Steer Left solenoid Axle 4
6255	Steer Left solenoid Axle 5
6256	Steer Left solenoid Axle 6
6257	Steer Left solenoid Axle 7
6258	Steer Left solenoid Axle 8
6259	Steer Left solenoid Axle 9
6261	Steer Right solenoid Axle 1
6262	Steer Right solenoid Axle 2
6263	Steer Right solenoid Axle 3
6264	Steer Right solenoid Axle 4
6265	Steer Right solenoid Axle 5
6266	Steer Right solenoid Axle 6
6267	Steer Right solenoid Axle 7
6268	Steer Right solenoid Axle 8
6269	Steer Right solenoid Axle 9
6270	Stabilizer Left Front extend solenoid
6271	Stabilizer Right Front extend solenoid
6272	Stabilizer Left Rear extend solenoid
6273	Stabilizer Right Rear extend solenoid
6274	Stabilizer Left Front retract solenoid
6275	Stabilizer Right Front retract solenoid
6276	Stabilizer Left Rear retract solenoid
6277	Stabilizer Right Rear retract solenoid
6278	Extension Beam Left Front extend solenoid
6279	Extension Beam Right Front extend solenoid
6280	Extension Beam Left Rear extend solenoid
6281	Extension Beam Right Rear extend solenoid
6282	Extension Beam Left Front retract solenoid
6283	Extension Beam Right Front retract solenoid
6284	Extension Beam Left Rear retract solenoid
6285	Extension Beam Right Rear retract solenoid
6286	Suspension Group Left Front solenoid
6287	Suspension Group Right Front solenoid
6288	Suspension Group Left Rear solenoid
6289	Suspension Group Right Rear solenoid
6290	Axle Lifting Front Left solenoid

Fault Code	Component Description
6291	Axle Lifting Front Right solenoid
6292	Axle Lifting Rear Left solenoid
6293	Axle Lifting Rear Right solenoid
6294	Pressure Axle Lifting Front Left solenoid
6295	Pressure Axle Lifting Front Right solenoid
6296	Pressure Axle Lifting Rear Left solenoid
6297	Pressure Axle Lifting Rear Right solenoid
6298	Drive out cylinder, Jib moves ahead from boom
6299	Retract cylinder, jib moves to boom
6400	Main Hoist Down solenoid
6401	Main Hoist Up solenoid
6402	Aux Hoist Down solenoid
6403	Aux Hoist Up solenoid
6404	Derricking Down solenoid
6405	Derricking Up solenoid
6406	Tele Cylinder Extend solenoid
6407	Tele Cylinder Retract solenoid
6408	Slewing Right solenoid
6409	Slewing Left solenoid
6410	Lower Brake Main Hoist solenoid
6411	Raise Lower Brake Main Hoist solenoid
6412	Lower Brake Aux Hoist solenoid
6413	Raise Lower Brake Aux Hoist solenoid
6414	Pilot Supply solenoid
6415	Slew Brake Release solenoid
6416	Enable high Speed Tele solenoid
6417	Lock Telecylinder Boom Section solenoid
6418	Charge Cylinder Tube solenoid
6419	Release Boom Down solenoid
6420	Hold Unlock Position solenoid
6421	Select Boom Section Telecylinder solenoid
6422	Jib Down solenoid
6423	Jib Up solenoid
6424	Cabin Down solenoid
6425	Cabin Up solenoid
6426	Turntable Lock solenoid
6427	Turntable Unlock solenoid
6428	Counterweight Lower solenoid

Fault Code	Component Description
6429	Counterweight Raise solenoid
6430	Counterweight Unlock solenoid
6431	Counterweight Lock solenoid
6432	Aux hoist carrier raise
6433	Aux hoist carrier lower
6434	Aux hoist lock
6435	Aux hoist unlock
6436	Main hoist Fast Moving
6437	Aux hoist Fast Moving
6438	Pressure Limiter Valve
6600	Main Hoist Speed Control PWM output
6601	Aux Hoist Speed Control PWM output
6602	Derricking Speed Control PWM output
6603	Telescoping Speed Control PWM output
6604	Slewing Speed Control PMW output
6605	Boom Down Release PWM output
6606	Tele Pressure Extend PWM output
6607	Slew Brake PWM output
6608	Aux Drives Speed Control PWM output
6609	Oil Cooler 1A PWM output
6610	Oil Cooler 1B PWM output
6611	Oil Cooler 2A PWM output
6612	Oil Cooler 2B PWM output
6614	Oil heater cooler
7001	Hydac Pressure Sensor (default node ID)
7002	SCM0
7003	SCM1
7004	SCM2
7005	SCM3
7013	Pressure sensor lower chamber 0
7014	Pressure sensor lower chamber 1
7015	Pressure sensor upper chamber
7017	Length sensor BOOM length
7018	Length sensor telecylinder length
7019	Telescoping Cylinder CAN length sensor
7020	Boom angle sensor 0
7021	Boom angle sensor 1
7022	Jib angle sensor

Fault Code	Component Description
7025	CCM10
7026	CCM11
7027	CCM12
7028	CCM13
7032	IOL30
7033	IOL31
7034	IOL32
7035	IOL33
7036	IOL34
7037	IOL35
7038	IOL36
7039	IOL37
7040	IOL38
7041	IOL39
7042	IOL40
7043	IOL41
7044	IOL42
7045	IOL43
7046	IOL44
7047	IOL45
7048	Slew Angle Sensor
7052	IOS20
7053	IOS21
7054	IOS22
7055	IOS23
7056	IOS24
7057	IOS25
7058	IOS26
7059	IOS27
7065	Slew angle sensor
7066	Boom angle sensor 0 GMK
7067	Boom angle sensor 1 GMK
7068	Boom length sensor
7075	Machine Display Extended
7081	Boom Handset
7082	Turntable Handset
7084	Carrier Left Handset
7085	Carrier Right Handset

Fault Code	Component Description
7090	Simulated Joystick
7091	Left joystick
7092	Right joystick
7093	Left joystick
7100	Remote Control -or- Slew Angle Sensor (default node ID)
7101	MMI Left
7102	MI Right
7106	External Light Tower
7108	Service Software
7109	Outside Light bar
7111	RCL display
7112	Operating display
7113	Carrier Display
7119	Jogdial
7123	Inside Light bar
7124	Cranestar
7129	J1939 Communications
7400	Engine RPM speed sensor
7401	Alternator Charge Frequency input
8000	RCL software
8001	Error List
8002	Operating system task 1
8003	Operating system task 2
8004	Operating system task 3
8005	Operating system task 4
8006	Operating system task 5
8007	Speed limit software
8008	RCL load charts
8009	AddReadSDO software function
8010	AddWriteSDO software function
8011	Telescoping software
8012	Interpolator / CCM closed loop current control
8013	Pinning program
8014	Slewing control system
8015	Derricking control system
8016	Main Hoist control system
8017	Aux Hoist control system
8100	Main Software Program

Fault Code	Component Description
8400	Eeprom
8401	CPU watchdog
8402	Data Flash
8600	RCL Boom Length
8601	RCL Slewing Range
8602	RCL Outrigger
8603	RCL Jib
8700	Telescoping Length Sensor Comparison
8701	Pinning Proxy Switches Left
8702	Pinning Proxy Switches Right
8900	Engine Type Selection (eeprom setting)
10100	Proximity Sensor Drum 0 (A)
10101	Proximity Sensor Drum 0 (B)
10102	Proximity Sensor Drum 1 (A)
10103	Proximity Sensor Drum 1 (B)
10104	Proximity Sensor Drum 2 (A)
10105	Proximity Sensor Drum 2 (B)
10106	Proximity Sensor Drum 3 (A)
10107	Proximity Sensor Drum 3 (B)
10108	Proximity Sensor Drum 4 (A)
10109	Proximity Sensor Drum 4 (B)
10110	Proximity Sensor Drum 5 (A)
10111	Proximity Sensor Drum 5 (B)
10112	Proximity Sensor Drum 6 (A)
10113	Proximity Sensor Drum 6 (B)
10114	Proximity Sensor Drum 7 (A)
10115	Proximity Sensor Drum 7 (B)
10116	Proximity Sensor Drum 8 (A)
10117	Proximity Sensor Drum 8 (B)
10118	Proximity Sensor Drum 9 (A)
10119	Proximity Sensor Drum 9 (B)
10120	Luffing Jib Min
10121	Luffing Jib Max
10123	Fixed Jib Confirm
10125	Boom Strap Load Cell Right
10126	Boom Strap Load Cell Left
10130	Proximity Sensor Output (V+) Drum 0
10131	Proximity Sensor Output (V+) Drum 1

Fault Code	Component Description
10132	Proximity Sensor Output (V+) Drum 2
10133	Proximity Sensor Output (V+) Drum 3
10134	Proximity Sensor Output (V+) Drum 4
10135	Proximity Sensor Output (V+) Drum 5
10136	Proximity Sensor Output (V+) Drum 6
10137	Proximity Sensor Output (V+) Drum 7
10138	Proximity Sensor Output (V+) Drum 8
10139	Proximity Sensor Output (V+) Drum 9
10140	Boom Strap Load Cell Output (V+)
10141	Lower/Upper Boom Point A2B Slow Output (V+)
10142	Lower/Upper Boom Point A2B Stop Output (V+)
10143	Luffing Jib Max Output (V+)
10144	Luffing Jib Min Output (V+)

Condition Codes

Fault Code	Condition Description
0	No Error
1	Over Current
2	Cable Break
3	Short to Battery
4	Short to Ground
5	Resistor Low
6	Resistor High
7	Below minimum level
8	Above maximum level
10	Undefined Area
11	Initialization failed
12	System
13	Function Error
14	Logic
15	Fuse
16	PWM Signal
17	8.5V supply below the minimum allowed voltage
18	8.5V supply above the maximum allowed voltage
19	Relay failure
20	The total current of all outputs is too high
21	Out of tolerance
22	Too many write SDOs for this device
23	Too many read SDOs for this device
24	Component is not calibrated
25	A sensor with redundant inputs has both at the same state: They must be opposite to each other
26	Two opposite input switches are both active. Example: Outrigger Extend & Retract
27	Joystick X axis fault
28	Joystick Y axis fault
29	Calibration invalid: The calibration points are too close to each other.
30	The power supply voltage is too low
31	The internal supply voltage UE is too low
32	The internal supply voltage UB1 is too low
33	The internal supply voltage UB2 is too low
34	The internal supply voltage UC1 is too low

Fault Code	Condition Description
35	The internal supply voltage UC2 is too low
36	Analog Input error
37	Digital Input error
38	Digital Output error
39	PWM Output error
40	Task Time too long
41	Data is not valid
42	Device is not operational
43	Could not get semaphore
44	Data does not match required data
45	The counter from a connected CAN device is no longer being updated. The data is considered no longer valid.
46	A CAN device is reporting a self-detected error
47	The pinning system could not unlock within the required time limit
48	The current operating mode is invalid
49	Movement in opposite direction
50	Unintentional Lock
52	The internal supply voltage UF is too low
53	The internal supply voltage UE is too low
54	The internal supply voltage UF is out of range
55	The internal supply voltage UB1 is out of range
56	The internal supply voltage UB2 is out of range
57	The internal supply voltage UC1 is out of range
58	The internal supply voltage UC2 is out of range
59	The external supply voltage EXT is out of range
60	Outrigger base too small
61	Jib angle tolerance
128	The last reset was because the watchdog detected that Ue was above the maximum allowed value
129	The last reset was because the watchdog detected that Ue was below the minimum allowed value
130	The last reset was because the watchdog detected that the system voltage was above the maximum allowed value
131	The last reset was because the watchdog detected that the system voltage was below the minimum allowed value
132	The last reset was because the watchdog detected an error as defined by the user
133	The last reset was because the watchdog detected a system error

Fault Code	Condition Description
134	The last reset was because the watchdog detected a configuration error
137	Unexpected NULL pointer
140	Command not zero. The joystick or tele pedal command must be zero to enable a function.
150	Pressure negative and positive
151	Pressure negative at positive
152	Pressure positive at negative
153	Pressure positive at stop
154	Pressure negative at stop

Reference Only

Device Codes

Fault Code	Device Description
	SCM0
1	SCM1
2	SCM2
3	SCM3
10	CCM10
11	CCM11
12	CCM12
13	CCM13
20	IOS20
21	IOS21
22	IOS22
23	IOS23
24	IOS24
25	IOS25
26	IOS26
27	IOS27
30	IOL30
31	IOL31
32	IOL32
33	IOL33
34	IOL34
35	IOL35
36	IOL36
37	IOL37
38	IOL38
39	IOL39
40	IOL40
41	IOL41
42	IOL42
43	IOL43
44	IOL44
45	IOL45
50	Joystick Left
51	Joystick Right

Index Codes

Fault Code	Index Description
0-29	Digital Inputs
48-95	Digital Outputs
96-110	Analog Inputs
128	Internal measurement
129	CAN bus 1
130	CAN bus 2
131	CAN bus 3
132	CAN bus 4
140	Eeprom Read - backup area
141	Eeprom Read - customer area
142	Eeprom Write - backup area
143	Eeprom Write - customer area
144	Not Applicable
145	Internal Software
150	Pressure logic

Reference Only

THIS PAGE BLANK

SECTION 4

BOOM

SECTION CONTENTS

Description	4-1	Boom Nose Sheaves	4-15
Safety	4-1	Boom Nose Sheaves Removal	4-16
Boom System Components	4-2	Boom Nose Sheaves Installation	4-16
Telescope Cylinder	4-2	Boom Assembly Procedure	4-17
Fly Section Extension Cables	4-2	Install Tele Cylinder	4-17
Extend Synchronizing Cable	4-2	Install the Outer Mid Section	4-20
Fly Retraction Cables	4-2	Install the Inner Mid Section	4-24
Outer Mid Retract Cables	4-2	Install the Base Section	4-29
Boom Extension Sequence	4-2	Final Boom Assembly	4-31
Boom Retract Sequence	4-4	Swingaway Extension Installation	4-32
Telescope Circuit	4-4	Tensioning the Boom Extend and	
Description	4-4	Retract Cables	4-34
Theory Of Operation	4-4	Boom Maintenance	4-36
Lift Circuit	4-4	Functional Test Of The Boom	4-36
Description	4-4	Boom Inspection	4-36
Theory Of Operation	4-4	Boom Alignment And Servicing	4-36
General Maintenance Notes	4-5	Extension And Retraction Cable Maintenance ..	4-37
Swingaway Extension Removable	4-5	Inspection	4-37
Boom Removal	4-6	Telescope Circuit Troubleshooting	4-38
Disconnect the Base Section	4-7	Lift Circuit Troubleshooting	4-40
Remove the Base Section	4-8	Lift Cylinder Maintenance	4-42
Disconnect the Inner Mid Section	4-10	Lift Cylinder Removal	4-42
Remove the Inner Mid Section	4-10	Lift Cylinder Disassembly And Assembly	4-42
Remove the Outer Mid Section	4-13	Lift Cylinder Installation	4-42
Remove the Tele Cylinder	4-14		

DESCRIPTION

The crane is equipped with a four section 9.8 to 31.0 m (32.3 to 101.7 ft), synchronized full power, cable extended boom.

The boom is rectangular in design and utilizes one two-stage double-acting, rod ported telescope cylinder. The telescoping sections are supported on graphite impregnated nylatron wear pads. Adjustable side wear pads prevent metal to metal contact between the sections.

Boom assembly lift is provided by a single lift cylinder. Boom elevation range is from -3 to 76 degrees.

An optional auxiliary boom nose (rooster sheave) is available for the boom to simplify single part cable usage. The rooster

sheave is installed on the main boom nose and is secured by pins that pass through the rooster sheave.

The boom has a 7.92 m (26 ft) offsetable or a 7.92 to 13.7 m (26 to 45 ft) telescoping offsetable swingaway boom extension provided to obtain additional boom reach. The boom extension mounts directly to the boom nose utilizing a four point attachment. The boom extensions may be offset at 0 to 30 degrees. In addition, the swingaway can be stowed on the right side of the boom base section.

Safety

Do not attempt to work on the boom without experienced supervision.

**DANGER**

To prevent serious injury or death, always wear personal protective equipment; i.e., a hard hat, eye protection, gloves and metatarsal boots.

BOOM SYSTEM COMPONENTS**Telescope Cylinder**

The telescope cylinder is attached to the boom in three places: Refer to Figure 4-1 for item location.

- The outer rod end (1) of the telescope cylinder is secured to the boom base section (2)
- The inner rod end (3) is secured to the inner mid section (4)
- The cylinder barrel (5) is secured to the outer mid section (6)

Fly Section Extension Cables

The fly section has five extension cables (7) attached to it. Refer to Figure 4-1 for item location.

The extension cables (7) are secured to the inner mid section (8) and are routed around a five groove sheave assembly (9) at the barrel end (boom nose) of the telescope cylinder (10). These cables are secured at the base end of the fly section (11).

Extend Synchronizing Cable

Refer to Figure 4-1 for item location. The long extend synchronizing cables (12) are connected to the rear of the

outer mid section (6) and is routed around two sheaves (11) on the top front of the inner mid (4), and secured to the rear of the base section (13).

Fly Retraction Cables

Refer to Figure 4-1 for item location. The two retraction cables (14) are secured at the outside front of the inner mid section (4), are routed around sheaves (15) mounted on the end of the outer mid section (6) and are secured at the opposite end (16) to the fly section (17).

Outer Mid Retract Cables

Refer to Figure 4-1 for item location. The four retraction cables (18) are secured at the outside front of the base section (2), are routed around sheaves (19) mounted on the end of the inner mid section (4) and are secured (20) at the opposite end to the outer mid section (6).

BOOM EXTENSION SEQUENCE

Refer to Figure 4-1 for item location. As the telescope cylinder extends, the cylinder barrel (5), which is attached to the outer mid section (6), and the inner cylinder rod (3) which is attached to the inner mid section (4), pulls the mid sections out along with it.

At the same time, the five groove sheave assembly (9) at the nose end of the telescope cylinder pulls on the five fly extension cables around it. This causes the fly section (17) and mid sections (6, 4) to deploy at the same time and rate.

The long extend synchronizing cable (12) ensures the mid sections and the telescope cylinder remain in synchronization.

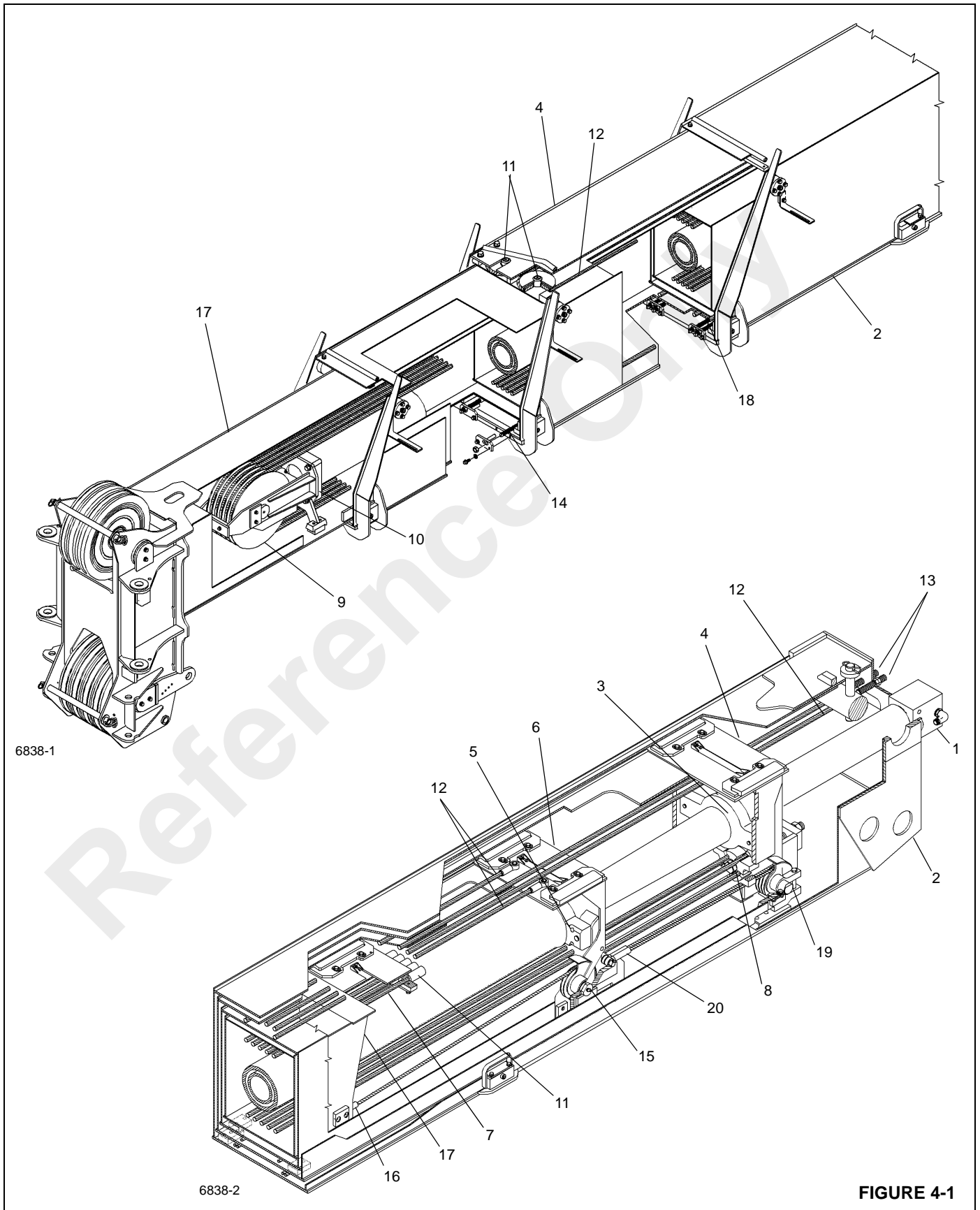

FIGURE 4-1

BOOM RETRACT SEQUENCE

Refer to Figure 4-1 for item location. As the telescope cylinder is retracted, the outer mid section (6) (attached to the cylinder barrel) and the inner mid section (4) (attached to the inner cylinder rod) are pulled in.

During retraction the two fly and four outer mid retraction cables are forced around sheaves (15, 19) at the rear of the mid section. This cable arrangement keeps the fly section, outer mid section, and the telescope cylinder in the proper sequence and timing.

TELESCOPE CIRCUIT

Description

The boom telescope circuit consists of the telescope function remote control, telescope directional control valve, holding valve, and the telescope cylinder.

NOTE: If the crane is equipped with an auxiliary hoist, the telescope function is controlled by a foot pedal instead of a controller.

The telescope control valve is the closed spool type and is described under Valves (pg 2-27).

Refer to Valves (pg 2-27) for a complete description of the telescope function remote control.

The boom telescope cylinder is a two stage double acting, rod ported cylinder. Foreign material is prevented from entering the cylinder by a wiper seal during rod retraction. O-ring seals prevent internal and external leakage. Refer to Cylinders (pg 2-54) for a complete description of the telescope cylinder.

The holding valve is threaded into a port block on the inner rod end of the telescope cylinder. The holding valve functions during the retraction, extension, or holding operation. When holding the boom section at a given length, oil is trapped in the cylinder by the holding valve. Refer to Holding Valves (pg 2-40) for a complete description of the holding valve.

Theory Of Operation

Flow from the pump travels to the telescope directional control valve. Movement of the control lever for telescope functions from neutral sends a pilot pressure signal to the directional control valve to shift the spool in the directional control valve. This aligns the appropriate passages in the control valve to route oil to the telescope cylinder holding valve. The holding valve, with its internal make-up of valves and springs, passes oil to and from the telescope cylinder. During extension, oil unseats the poppet (check) valve in the holding valve. This oil is routed to the piston sides of the cylinder which forces the rods out of the cylinder, causing the boom section to extend.

During retraction, oil enters the retract port and flows to the rod sides of the cylinder. When pilot pressure reaches a pre-determined value, the main poppet unseats, and oil flows from the piston sides of the cylinder to the reservoir causing the boom section to retract. All return flow from the directional control valve goes to the reservoir.

LIFT CIRCUIT

Description

The boom lift circuit consists of the lift function remote control, lift directional control valve, holding valve, and the lift cylinder. These components enable the boom to be raised or lowered to various degrees of elevation ranging from -3 to +76 degrees from horizontal.

The lift directional control valve is the closed spool type and is described under Valves (pg 2-27).

Refer to Valves (pg 2-27) for a complete description of the lift function remote control.

The lift cylinder is the double acting type. Dirt and other foreign material is prevented from entering the cylinder and causing internal damage by a wiper seal during rod retraction. Oil seals on both the piston and cylinder head prevent internal and external hydraulic oil leakage. Refer to Cylinders (pg 2-54) for a complete description of the lift cylinder.

The holding valve is a balanced poppet type hydraulic valve. It is threaded into the port block which is an integral portion of the lift cylinder barrel. The holding valve functions when booming up (cylinder rod extended), booming down (cylinder rod retracted), or holding (cylinder rod stationary).

A velocity fuse is installed in the RCL piston transducer port of the lift cylinder port block. The velocity fuse is used to prevent inadvertent retraction (lowering) of the lift cylinder should the line to the transducer develop a leak. The fuse will close when flow reaches 11.4 L/min (3 gpm).

Theory Of Operation

The directional control valve bank housing the lift control valve is supplied by flow from the hydraulic pump.

When booming up, oil unseats the poppet (check) valve in the holding valve, letting oil flow to the piston side of the cylinder. Pressure is applied to the piston, forcing the rod to extend, raising the boom.

When booming down, oil enters the retract port of the port block and flows to the cylinder rod side. When pilot pressure reaches a pre-determined value, the main poppet unseats and oil flows from the piston side of the cylinder to the reservoir.

All return flow from the control valve goes to the reservoir.

GENERAL MAINTENANCE NOTES

- Apply medium strength thread locking adhesive/sealant and primer to all hardware except items Mid Syncro Cable threads, Fly Retract Cable threads, and Outer Mid Retract Cable threads.
- Unless otherwise specified, torque values for all metric class 8.6 and/or 0.9 and grade 5 and/or grade 6 fasteners shall be as specified under Fasteners and Torque Values (pg 1-11).
- Apply multipurpose grease to all wear surfaces.
- Adjust bottom front adjustable wear pads such that wear pad is within mm 1 from side plate or bottom plate of next inner section. Use shims only if section needs to be adjusted for twist.
- Adjust top rear adjustable wear pads such that the wear pad is just in contact with side plate of next outer section.
- To adjust lower side wear pads use shims so that wear pads are just in contact with the side plate of the next outer section.
- To adjust rear bottom wear pads use shims so that wear pads are within 2mm of the bottom plate of the next outer section.

SWINGAWAY EXTENSION REMOVABLE



DANGER

To prevent serious injury or death, always wear personal protective equipment; i.e., a hard hat, eye protection, gloves and metatarsal boots.



DANGER

Boom angles are used to control speed at which extensions swing during erecting and stowage. Improper boom angles will cause uncontrollable swing speeds of extension.

NOTE: Tag line used in these procedures is to control the movement of the boom extension.



DANGER

Before attempting to remove the boom extension; read and strictly adhere to all danger decals installed on the boom/boom nose, boom extension, and stowage brackets.

1. Visually check to ensure all pins are installed.
2. Crane should be set up on outriggers using normal setup procedures as found in the Operator Manual.
 - a. Fully retract boom.
 - b. Lower boom to horizontal for extending over the front of the crane for removal.
3. Remove the retainer clips from the right side attachment pins stowed in the base of the boom extension and remove the attachment pins from the boom extension. Insert the right side attachment pins (Figure 4-2, 1) through the boom attachment and boom extension anchor fittings (Figure 4-2, 2). Install the retainer clips in the attachment pins.

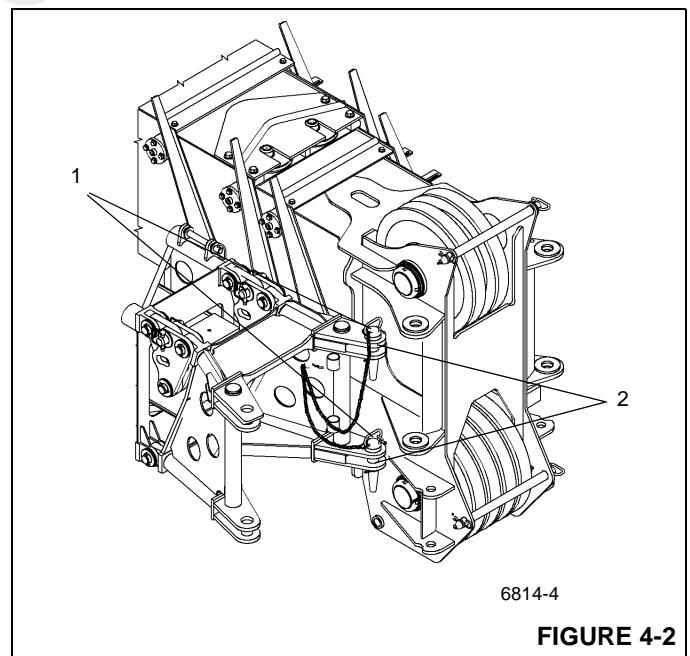

6814-4

FIGURE 4-2

4. Remove the retaining pin from the hitch pin (Figure 4-3, 3) that secures the boom extension to the rear stowage bracket. Remove the hitch pin, unlocking the boom extension from the boom.

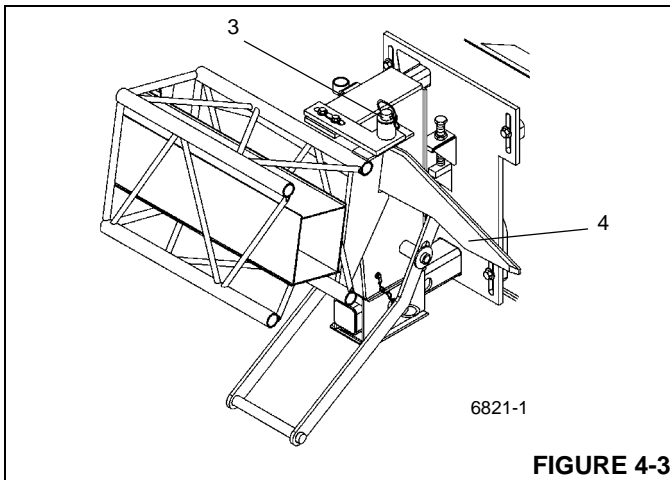

FIGURE 4-3

5. Attach a length of rope to the boom extension tip to aid in swinging the boom extension into place ahead of the boom nose.
6. Raise the boom to horizontal and extend the boom approximately 51 to 64 cm (20 to 25"). Make certain that the boom extension stowage lugs clear the guide pins (Figure 4-4, 1) and ramp (Figure 4-3, 4) on the front and rear stowage brackets.

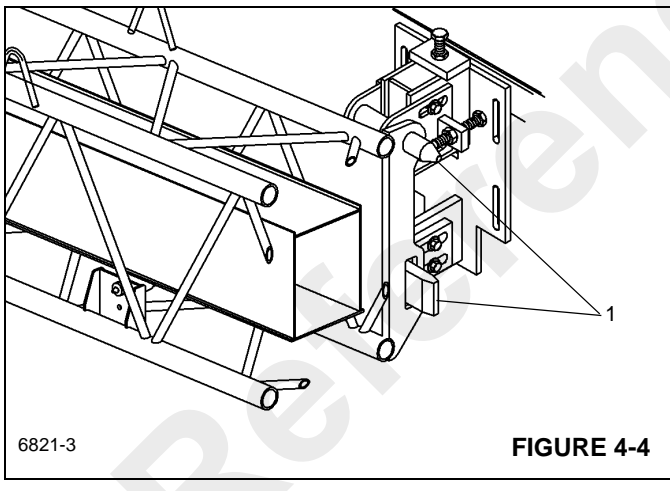

FIGURE 4-4

**DANGER**

When removing the boom extension, ensure that all personnel and equipment are kept clear of the swing path.

7. Slightly raise and/or lower the boom to help control the boom extension. Using the rope attached to the top of the boom extension, manually swing the extension into place ahead of the boom nose.
8. Attach a lifting device to the lifting lugs on the swingaway extension taking pressure off the attaching pins (Figure 4-2, 1). Remove the pins.

9. Place the now free swingaway extension in a safe secure location.

BOOM REMOVAL

Do not attempt to work on the boom without experienced supervision.

**DANGER**

To prevent serious injury or death, always wear personal protective equipment; i.e., a hard hat, eye protection, gloves and metatarsal boots.

NOTE: The boom may be disassembled with the base section left on the crane if repair of the base section is not necessary.

NOTE: The complete boom assembly weighs approximately 5800 kg (12,740 lb) without the swingaway boom extension attached. Removal of the swingaway boom extension will simplify boom removal.

1. Extend and set the outriggers to level the crane and ensure the boom is fully retracted and in a horizontal position over the front of the crane.
2. Fully retract the Boom.

**DANGER**

Wear gloves when handling wire rope.

3. Remove the hook block or headache ball and wind all the wire rope onto the hoist drum.
4. Elevate the boom slightly so that the lift cylinder is extended approximately 30.48 cm (12 in) to allow for withdrawal of the lift cylinder rod end from the lift cylinder lift box on the bottom of the boom.

**DANGER**

Ensure the boom lift cylinder is properly supported before disconnecting it from the boom.

Ensure all blocking and lifting devices are capable of supporting the boom assembly.

5. Shut down hydraulic power to crane.
6. With hydraulic power removed, move the Boom Extend control from "EXTEND" to "RETRACT" several times. This will relieve most residual pressure in Tele Circuit and make Tele Cylinder removal easier.

7. Attach a lifting device to the boom to provide for equal weight distribution.
8. Disconnect any electrical wiring from the boom.
9. Tag and disconnect the hydraulic lines to the telescope cylinder. Hard cap or plug the lines and openings.
10. Remove the bolt (Figure 4-5, 1) and washer securing the upper lift cylinder shaft (Figure 4-5, 2) to the side of the lift box (Figure 4-5, 3) on the boom.

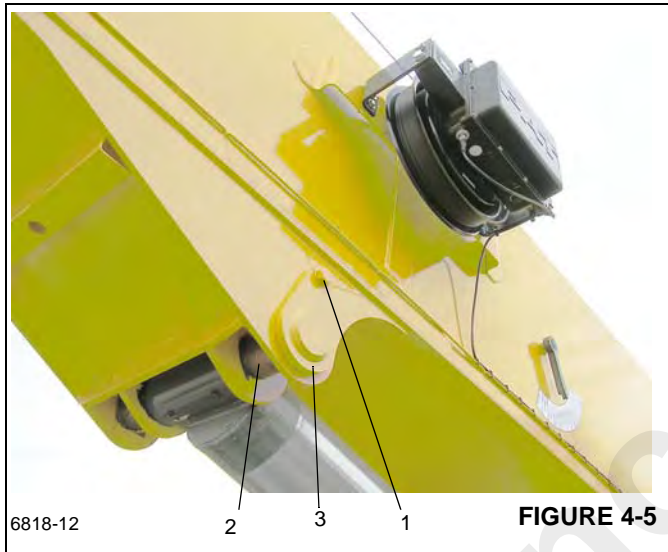

11. Remove the upper lift cylinder shaft (Figure 4-5, 2).
12. Activate the hydraulic system and withdraw the lift cylinder rod enough to clear the lift box (Figure 4-5, 3).
13. Take up the slack on the boom lifting device.

**DANGER**

Shut down the crane before proceeding.

14. Remove the clip pin and retaining pin (Figure 4-6, 1) securing the boom pivot shaft (Figure 4-6, 2) on the boom to the superstructure assembly.

15. Remove the grease fittings from the pivot shaft to prevent damage. Remove the boom pivot shaft.

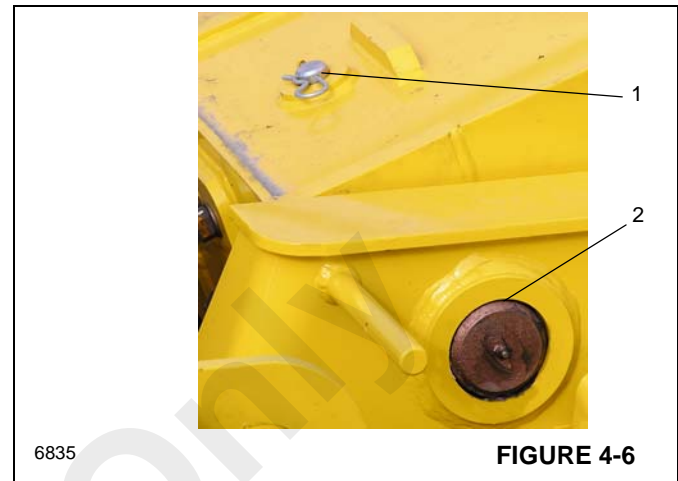

16. Raise the boom clear of the crane and lower to blocking or cribbing for service.

Disconnect the Base Section

Do not attempt to work on the boom without experienced supervision.

**DANGER**

To prevent serious injury or death, always wear personal protective equipment; i.e., a hard hat, eye protection, gloves and metatarsal boots.

1. Remove the boom from the crane superstructure in accordance with "Boom Removal" procedure.
2. Remove the RCL, A2B/Cable from boom nose.
 - a. Remove cover from junction box.
 - b. Disconnect "SHD" wire (Figure 4-7, 1) from terminal 1 and "CORE" wire (Figure 4-7, 2) from terminal 2.
 - c. Disconnect cable connector from side of junction box.

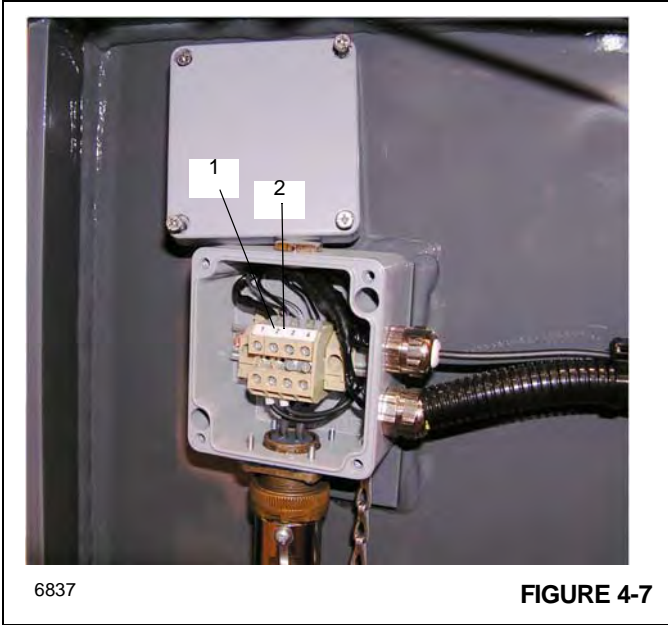

FIGURE 4-7

3. Disconnect cable from the Fly section (Figure 4-8, 3) and feed cable through cable guides (Figure 4-8, 1) and attach to the Base section cable guide (Figure 4-8, 2).

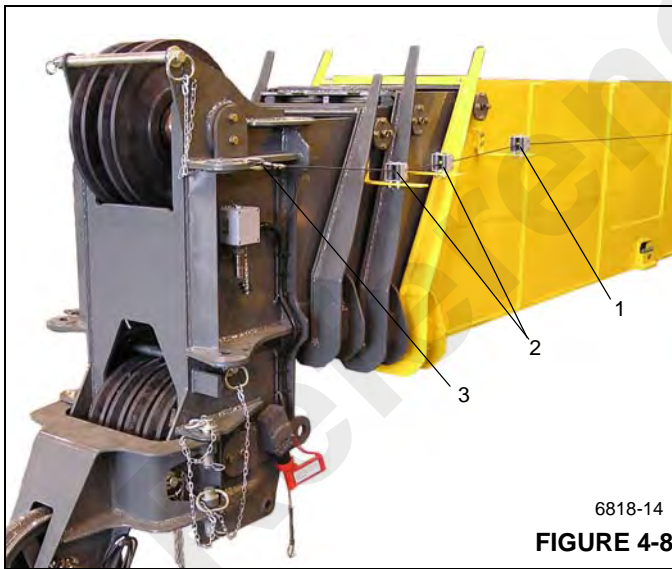
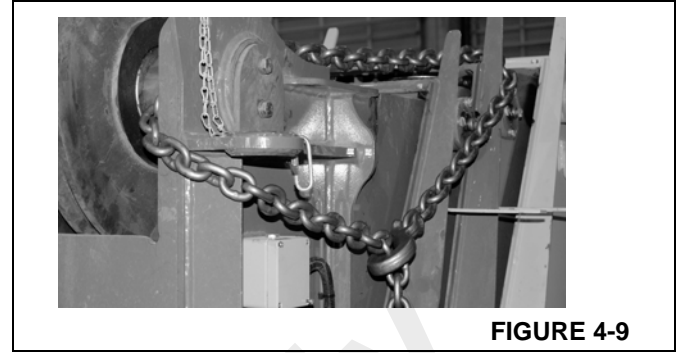

FIGURE 4-8

4. Chain the Fly, Outer Mid and Inner Mid sections together. This will prevent the inadvertent or unexpected extension of these sections during the boom disassembly. Figure 4-9



5. Remove the bolts and washers securing the telescope cylinder outer rod (Figure 4-10, 1) to the rear of the base section.



CAUTION

Use extreme caution during piston and rod tube assembly removal. The telescopic cylinder will still be under hydraulic pressure due to the holding valve.

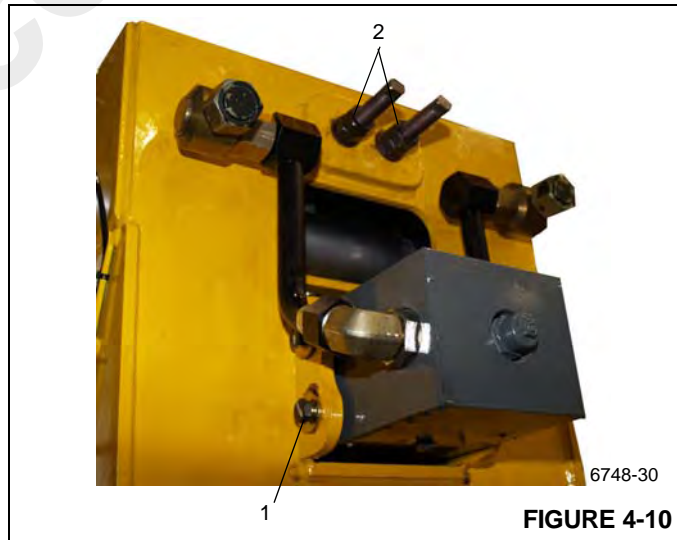

FIGURE 4-10

6. Remove the nuts and washers securing the synchronizing cable (Figure 4-10, 2) ends to the base section.

Remove the Base Section

Do not attempt to work on the boom without experienced supervision

**DANGER**

The combined weight of the boom inner mid, outer mid, and fly sections, including the telescope cylinder, is approximately 3680 kg (8110 lb). Ensure that adequate and properly tested lifting devices are used to remove these sections

**DANGER**

To prevent serious injury or death, always wear personal protective equipment; i.e., a hard hat, eye protection, gloves and metatarsal boots.

1. Remove the access cover (Figure 4-11, 1) on the top rear of the base section. Slide the assembly out of the base section (Figure 4-12, 1) enough to gain access to the top rear adjustable wear pads on the inner mid (Figure 4-12, 2).

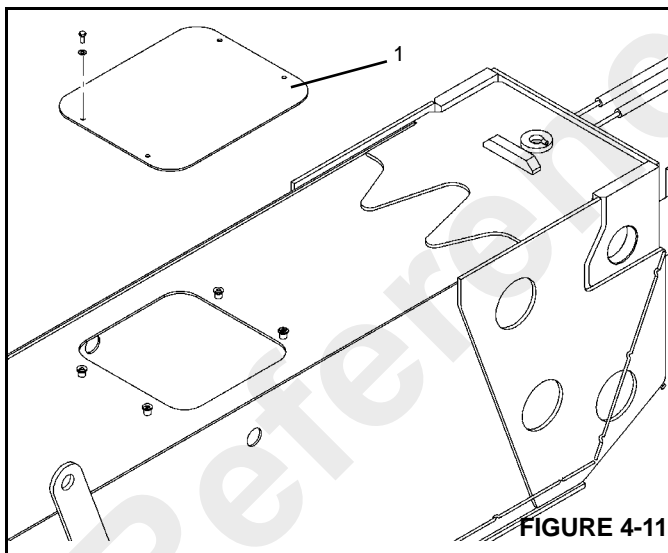

FIGURE 4-11



FIGURE 4-12

2. Remove the bolt (Figure 4-13, 1), washer, and offset washer securing each top rear adjustable wear pad and remove the wear pads, keeper plates and bolts (Figure 4-13, 2) from the top of the inner mid. Note location of wear pads and shims for installation.

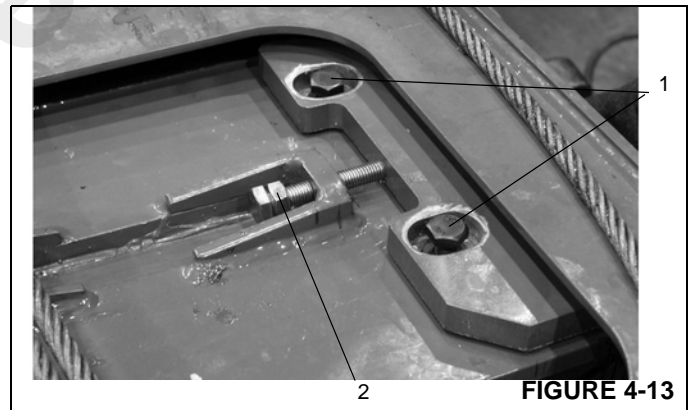

FIGURE 4-13

3. On the top front of the base section, remove the two bolts securing the kick back plate and remove the plates.
4. Remove the bolts securing the outer mid retract cable anchor plates to the lower front of the base section. Remove the cable locknuts and the anchor plates from the cables.
5. Remove the two screws securing each top (Figure 4-14, 1) and bottom (Figure 4-14, 2) side wear pads at the front of the base section. Remove wear pads, shims, and mounting angle (top left side only).

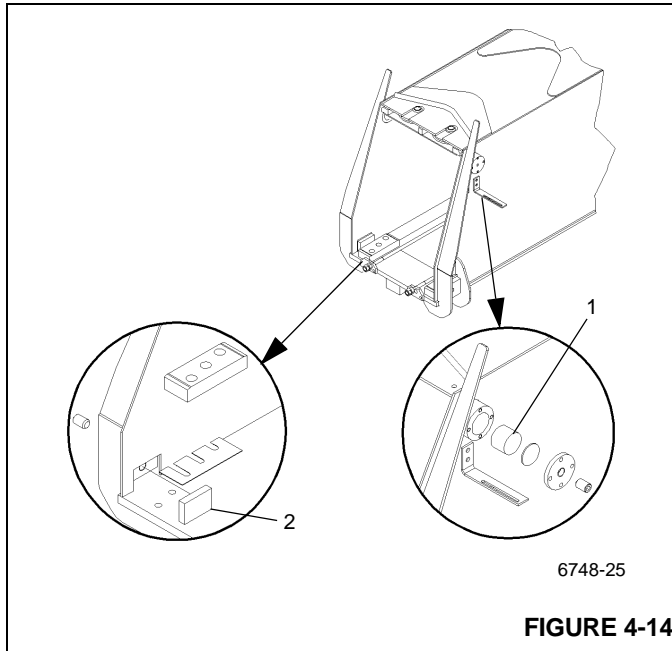

FIGURE 4-14

6. Attach a suitable lifting device to the Fly/Outer/Inner Mid assembly. Raise the front of the assembly slightly and remove the wear pad mounting bolts and the wear pads from the bottom of the base section.
 7. Continue to pull the assembly until it is clear of the base section.
- NOTE:** Pull the outer mid retract cables out with the assembly to prevent them from becoming damaged.
8. Place base section in a secure location

Disconnect the Inner Mid Section

Do not attempt to work on the boom without experienced supervision.

! DANGER

To prevent serious injury or death, always wear personal protective equipment; i.e., a hard hat, eye protection, gloves and metatarsal boots.

1. On both sides, remove the bolts (Figure 4-15, 1) securing each retract sheave assembly shaft weldment. Remove the shaft, spacer bushing, sheave assembly,

and thrust washers. If necessary, remove the grease fitting from the shaft weldments.

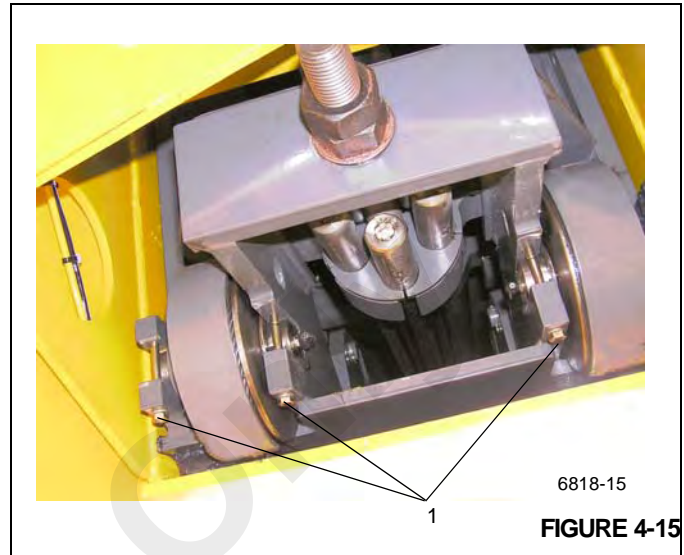

FIGURE 4-15

2. Remove the two bolts and bushings securing the cylinder inner rod (Figure 4-16, 1) to the rear of the inner mid (Figure 4-16, 2).

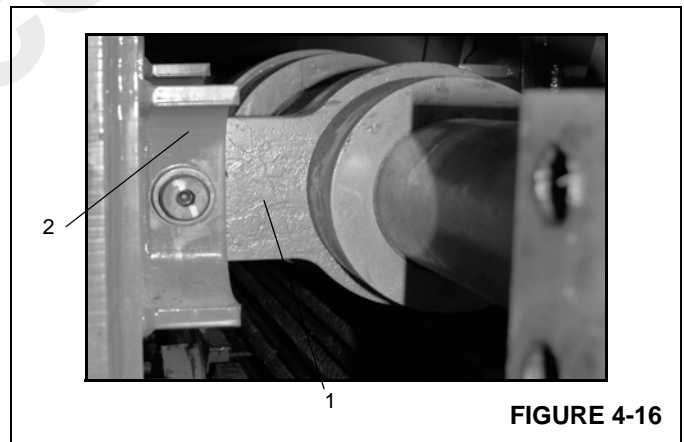

FIGURE 4-16

3. Remove the two nuts from the extend cable anchor plate adjusting bolts.
4. Pull the four retract cables up through the holes in the bottom of the inner mid and lay them out to the rear.

Remove the Inner Mid Section

Do not attempt to work on the boom without experienced supervision.

! DANGER

To prevent serious injury or death, always wear personal protective equipment; i.e., a hard hat, eye protection, gloves and metatarsal boots.

**DANGER**

The combined weight of the boom outer mid, and fly sections, including the telescope cylinder, is approximately 2550 kg (5610 lb). Ensure that adequate and properly tested lifting devices are used to remove these sections

1. Slide the assembly out of the inner mid (Figure 4-17, 1) enough to gain access to the top rear adjustable wear pads on the outer mid (Figure 4-17, 2) through the hole in the top of the inner mid.
2. Remove the bolt, washer, and offset washer securing each top rear adjustable wear pad and remove the wear pads, keeper plates (Figure 4-17, 3) and bolts from the top of the outer mid.

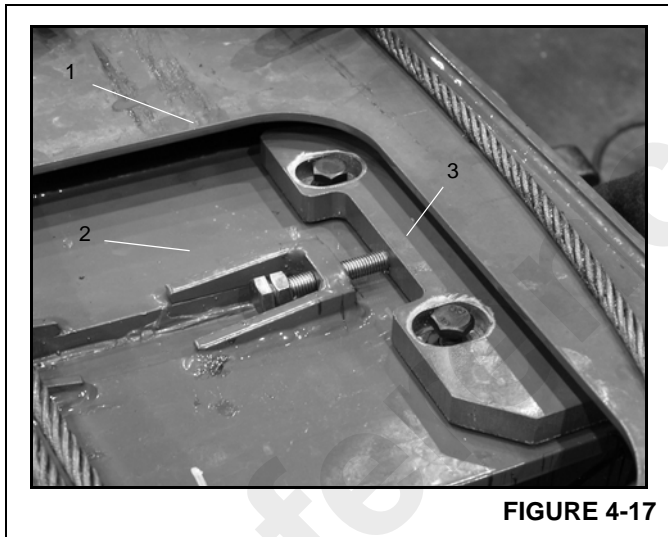
**FIGURE 4-17**

3. At the top front of the inner mid, remove the four bolts and washers securing the synchronizing cable sheave assembly (Figure 4-18, 1). Lay the assembly with cables on top of the outer mid.

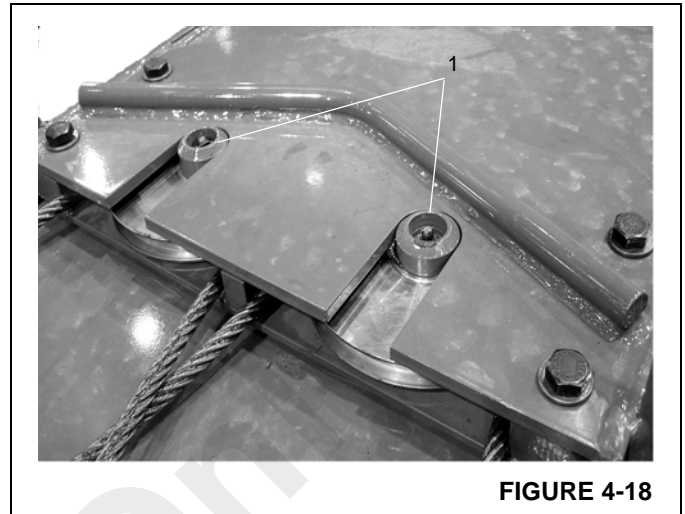
**FIGURE 4-18**

4. At the lower front of the inner mid, remove the bolts securing the fly retract cable anchor plates (Figure 4-19, 1). Remove the cable locknuts and the anchor plates from the cables.
5. Install thread protectors on cable ends.

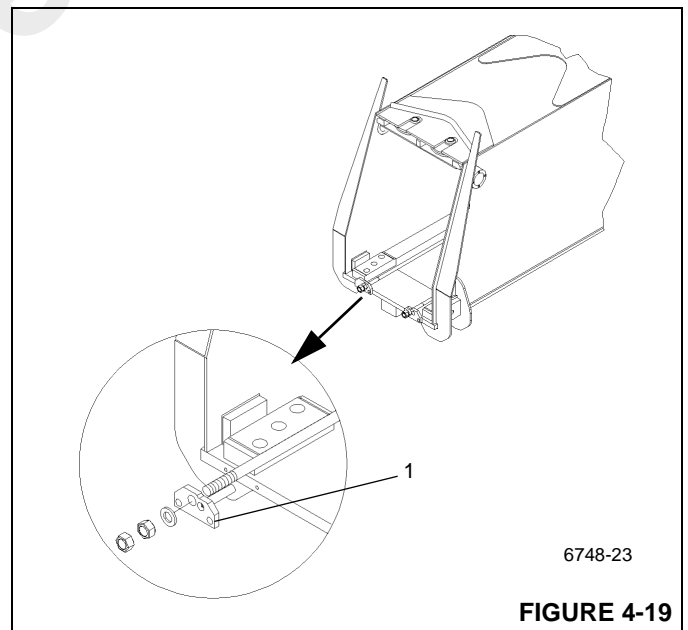

6748-23

FIGURE 4-19

6. Remove the screws securing each top (Figure 4-20, 1) and bottom side wear pads (Figure 4-20, 2) at the front of the inner mid. Remove wear pads, shims. Keep the shims with each individual wear pad for re-installation.
7. Remove the RCL cable guide mounting angle (Figure 4-20, 3) (top left side only).

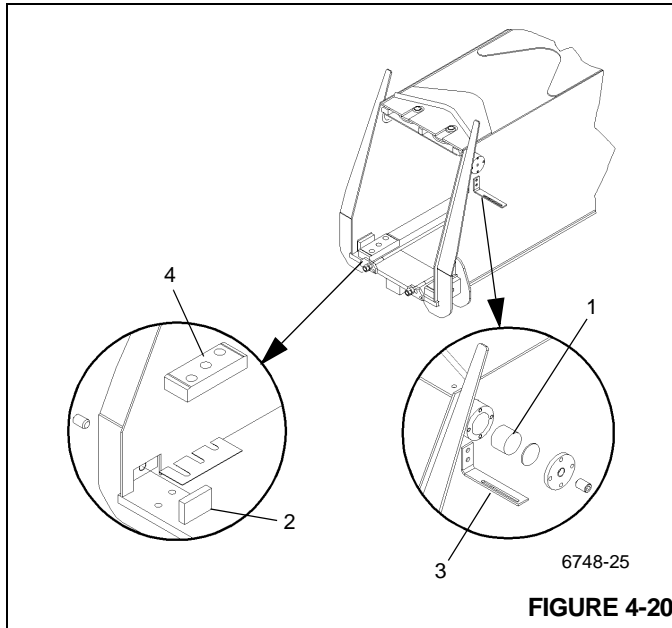

FIGURE 4-20

8. Lift up on the front of the assembly and remove the wear pad bolts and wear pads (Figure 4-20, 4) from the bottom of the inner mid. (Figure 4-20)
9. Remove the lock nut and adjustment nut (Figure 4-21, 1) from the extend cable adjustment bolt. This will free the extend cable from the inner mid weldment.

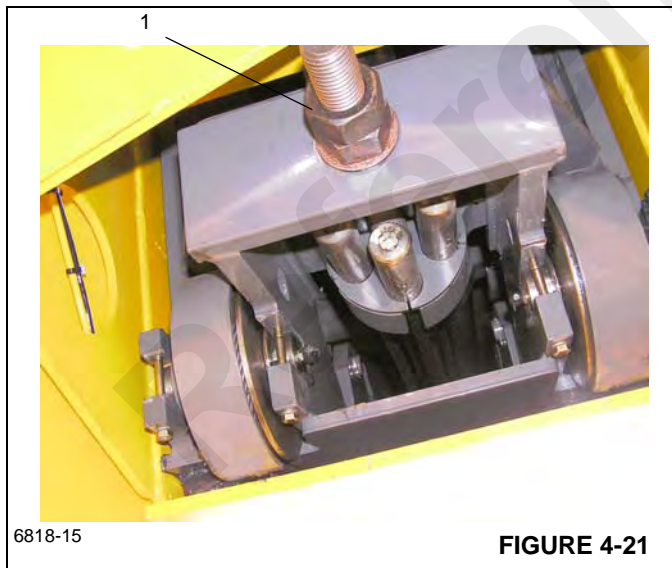

FIGURE 4-21

10. Secure the extend cable keeper plate and adjustment bolt to the tele cylinder with cable ties (Figure 4-22, 1) or tape. Failure to do so may allow the cables and keeper to become jammed during disassembly.

NOTE: It is not necessary to remove the extend cable keeper plates at this time. If it is necessary to remove the cable keeper plates, be sure to mark

the extend cable in the proper sequence for re-assembly.

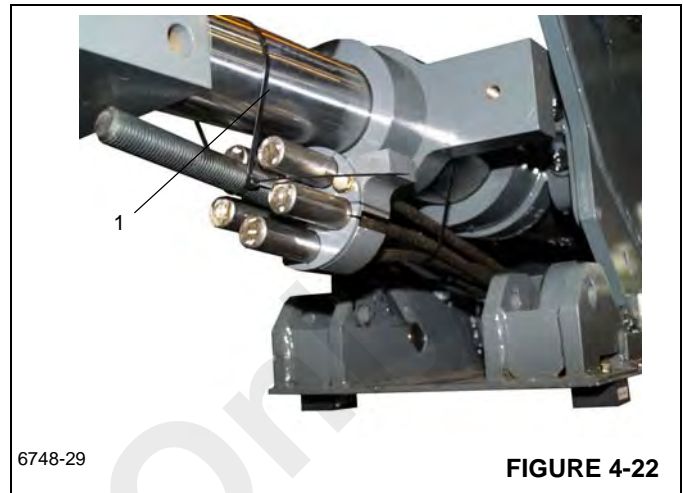

FIGURE 4-22

11. Continue to pull the assembly from the inner mid section until access to the rear of the outer mid is gained to disconnect the four retract cables (Figure 4-23, 1).
12. Remove the cotter pins and pins (Figure 4-23, 2) securing the four retract cables to the rear of the outer mid.

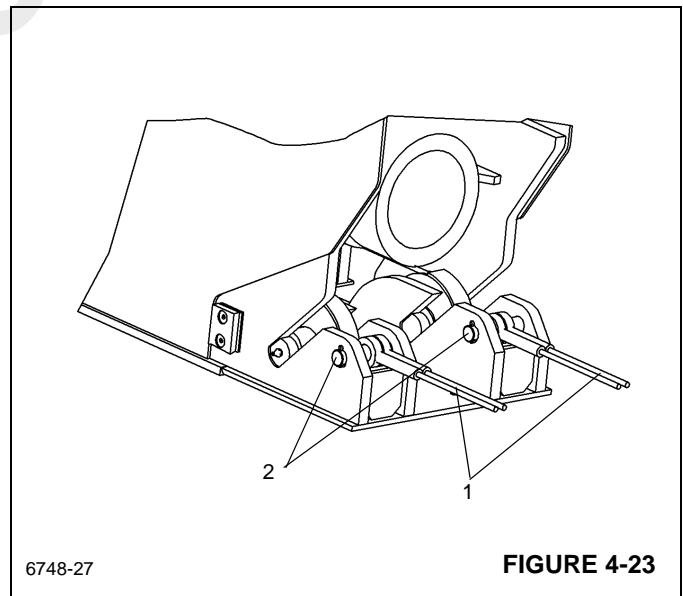

FIGURE 4-23

13. If necessary, remove the two bolts securing the bottom rear side wear pad to the inner mid. Remove wear pad.
14. If necessary, remove the two bolts securing each lower rear side wear pad to the inner mid. Remove wear pads and shims. Note location of shims for installation.
15. Remove the inner mid Section from outer/fly/tele cylinder assembly.

Remove the Outer Mid Section

Do not attempt to work on the boom without experienced supervision.



DANGER

To prevent serious injury or death, always wear personal protective equipment; i.e., a hard hat, eye protection, gloves and metatarsal boots.



DANGER

The combined weight of the boom fly section including the telescope cylinder, is approximately 1960 kg (3720 lb). Ensure that adequate and properly tested lifting devices are used to remove these sections

1. At the rear of the outer mid, on both sides, remove the bolt and cable retainer bushing from above each retract cable sheave assembly (Figure 4-24, 1).
2. Remove the shaft, spacer bushing, sheave assembly, and thrust washer. If necessary, remove the grease fitting from the shaft weldments.

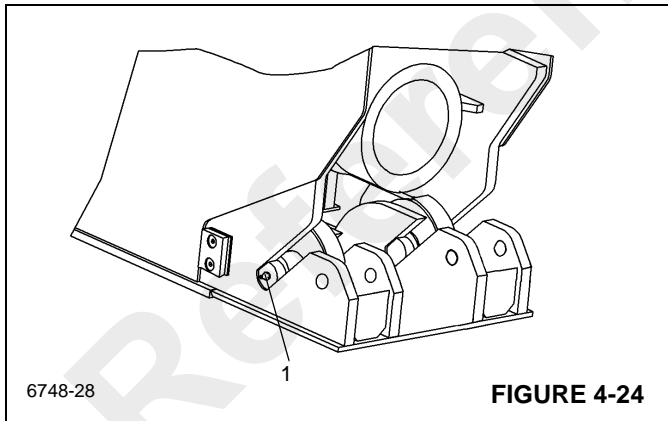

3. Place wood block (Figure 4-25, 1) under cylinder and remove the four bolts and bushings securing the cylinder barrel (Figure 4-25, 2) to the rear of the outer mid.

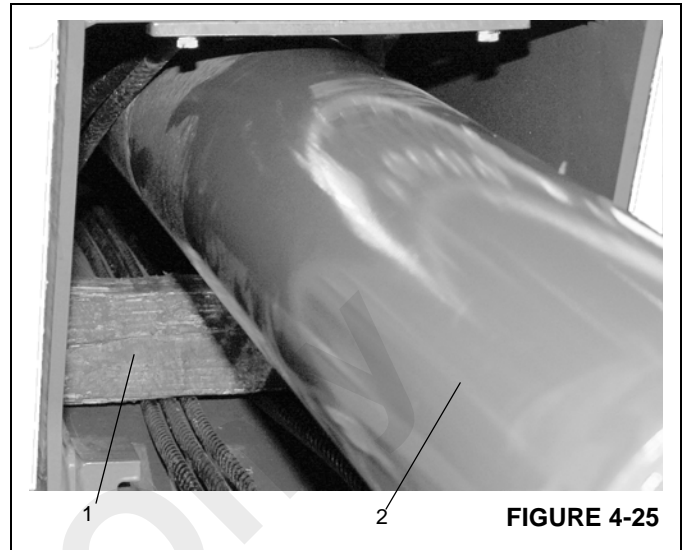

4. Pull the two retract cables up through the holes in the bottom of the outer mid and lay them out to the rear.
5. Turn cylinder rod inner mounting lugs (Figure 4-26, 1) so they are vertical to clear mounting bracket (Figure 4-26, 2) in the outer mid.

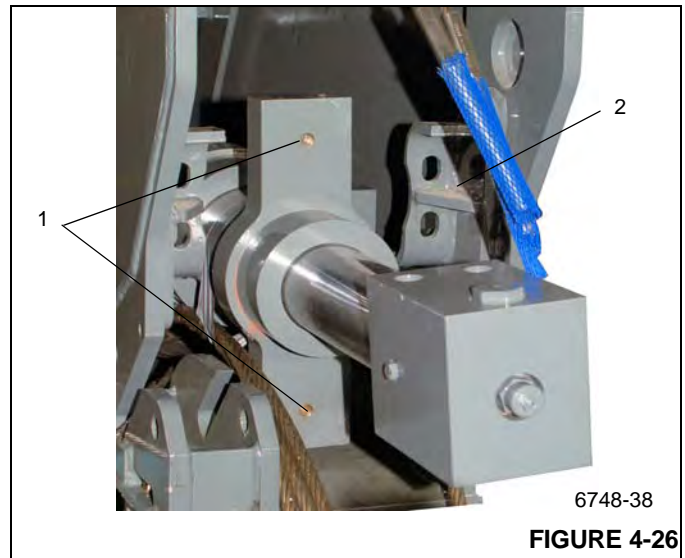

6. Slide the fly assembly out of the outer mid enough to gain access to the top rear adjustable wear pads on the fly through the hole in the top of the outer mid.
7. Remove the bolt, washer, and offset washer (Figure 4-27) securing each top rear adjustable wear pad and remove the wear pads, keeper plates and bolts from the top of the fly.

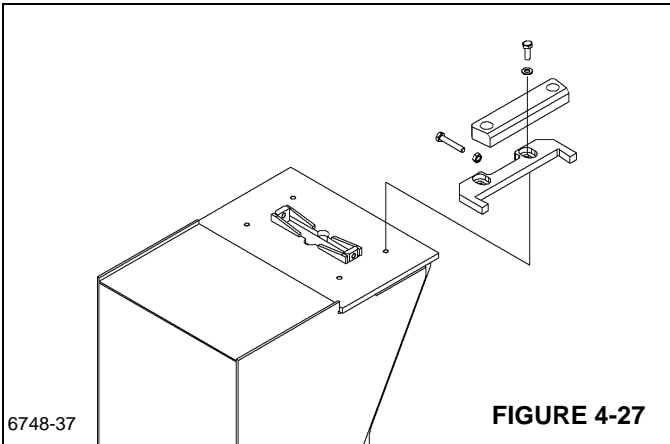

FIGURE 4-27

8. At the top front of the outer mid, remove the two bolts (Figure 4-28, 1) securing the kickback plate. Remove the kickback plate.

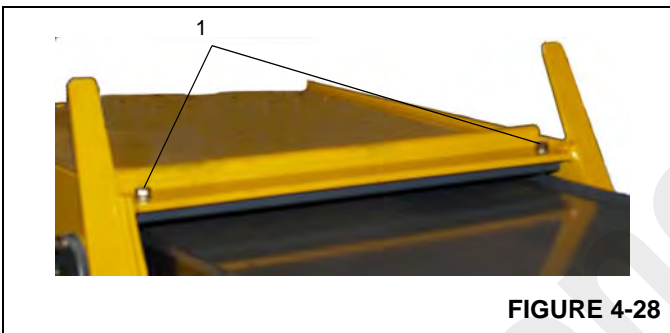

FIGURE 4-28

9. Remove the two screws securing each top (Figure 4-29, 1) and bottom (Figure 4-29, 2) side wear pads at the front of the outer mid. Remove wear pads, shims, and mounting angle (Figure 4-29, 3) (top left side only).

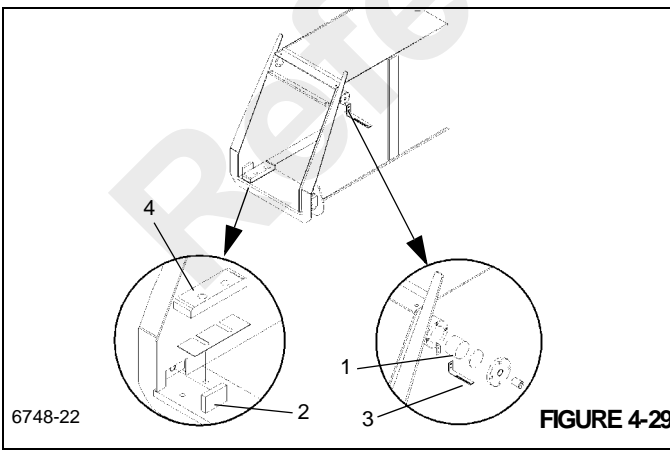

FIGURE 4-29

! DANGER

Be extremely careful when remove bottom wear pads. Do not place your hands or fingers in an area that could cause injury. Use approved tools to remove wear pads.

10. Lift up on the front of the fly assembly and remove the wear pads (4) from the pockets in the bottom of the outer mid.
11. Continue to pull the assembly from the outer mid section until access to the rear of the fly is gained to disconnect the two retract cables.
12. Remove the retaining plate securing the two fly retract cables (Figure 4-30, 1) to the rear of the fly.

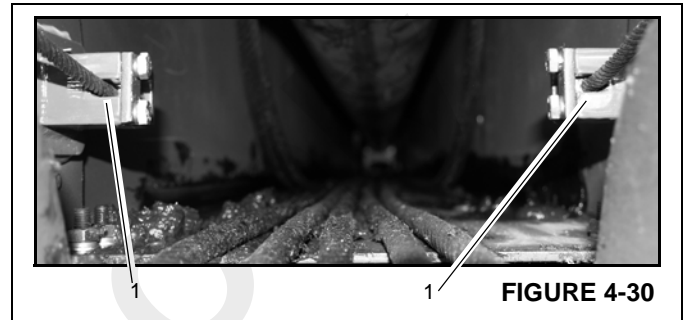

FIGURE 4-30

13. Remove the synchronizing cable and sheave assembly from the top of the outer mid.
14. Remove the two fly retract cables from the inside of the outer mid.
15. Remove the two bolts securing each lower rear side wear pad to the outer mid. Remove wear pads and shims. Note location of shims for installation.

Remove the Tele Cylinder

Do not attempt to work on the boom without experienced supervision..

! DANGER

To prevent serious injury or death, always wear personal protective equipment; i.e., a hard hat, eye protection, gloves and metatarsal boots.

! DANGER

The weight of the telescope cylinder is approximately 889 kg (1980 lb). Ensure that adequate and properly tested lifting devices are used to remove the telescope cylinder.

1. Attach a suitable lifting device to the Tele Cylinder. Raise cylinder and remove blocking device (Figure 4-25, 1) from under the cylinder.
2. Slide the Tele Cylinder out of the Fly Section until it is just ready to “drop out” of the section. Do not pull the Tele Cylinder completely out of the Fly Section yet.

NOTE: Pull the extend cable along with the telescope cylinder (Figure 4-31). Failure to do so will cause binding and jamming of the cables in the fly section.



FIGURE 4-31

3. Remove the two bolts securing the extend cable keeper plate (Figure 4-32, 1) to the rear of the fly. Remove the keeper plate and remove the five extend cable ends from the slots in the fly.

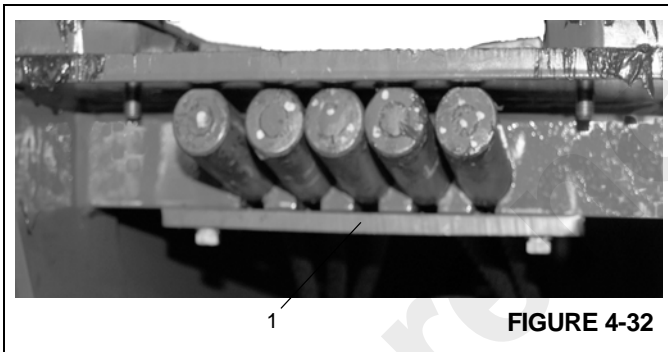

FIGURE 4-32

4. After supporting the weight of the tele cylinder, remove the two bolts securing the cylinder foot weldment (Figure 4-33, 1) to the telescope cylinder (Figure 4-33, 2). Remove the foot weldment.

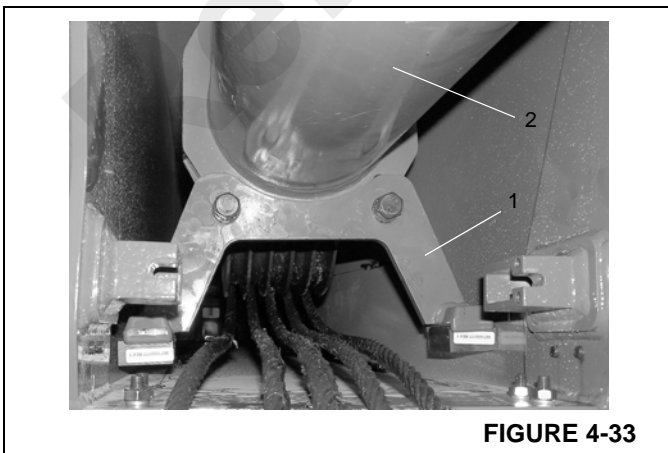

FIGURE 4-33

5. Completely remove the Tele Cylinder from the Fly Section.

6. Remove bottom and lower rear side wear pads and shims if they are to be replaced. Note location of shims for installation.

Extend Cable Sheave Removal

1. Remove the bolts holding the Cable Retainer (Figure 4-34, 1) to Sheave Mount (Figure 4-34, 2). Remove the Retainer.

NOTE: If the extend cables are to be reused, be sure that they are marked before removal to aid in reassembly.

2. Remove the five extend cables.

NOTE: The boom nose sheave weighs approximately 17.3 kg (38 lb).

3. Remove the sheave shaft retainer plates (Figure 4-34, 3) from left and right side of the sheave mount.

4. Carefully pull the sheave shaft (Figure 4-34, 4) from the assembly, removing the spacers, and sheave (Figure 4-34, 5). Note the quantity of the spacers for installation.

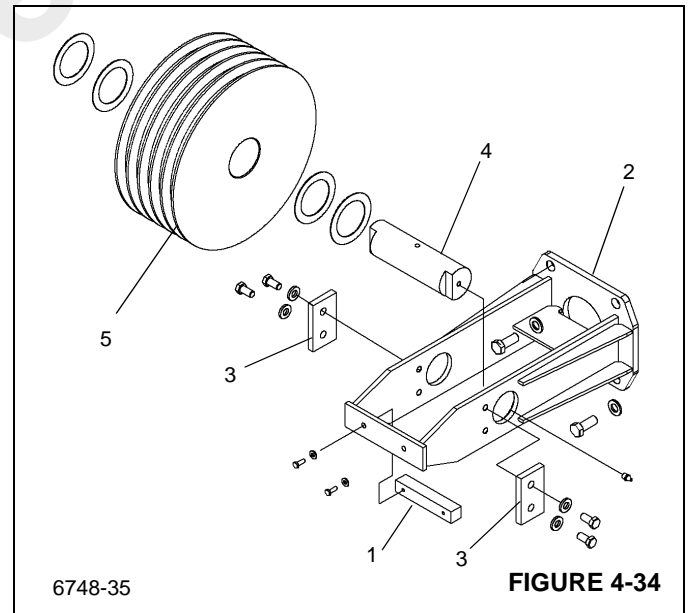

6748-35

FIGURE 4-34

BOOM NOSE SHEAVES

Do not attempt to work on the boom without experienced supervision.



To prevent serious injury or death, always wear personal protective equipment; i.e., a hard hat, eye protection, gloves and metatarsal boots.

Boom Nose Sheaves Removal

1. Remove the clip pins from the cable retainer pins (Figure 4-35, 7) and remove the cable retainer pins (Figure 4-35, 3) from the upper and lower part of the boom nose.
2. Remove the two bolts securing the end cap (Figure 4-35, 2) to the upper boom nose sheave shaft (Figure 4-35, 6). Remove the end cap.

NOTE: The boom nose sheave shafts weigh approximately 12.5 kg (27.5 lb) each. The boom

nose sheaves weigh approximately 17.4 kg (38 lb) each.

3. Carefully pull the upper boom nose sheave shaft (Figure 4-35, 6) from the boom nose, removing the spacers, and boom nose sheaves (Figure 4-35, 4). Note the quantity of the spacers for installation.
4. Repeat steps 2 and 3 and remove the lower boom nose sheave shaft.
5. Remove the shim, washer, keyed washer and locknut from both sheave shafts.

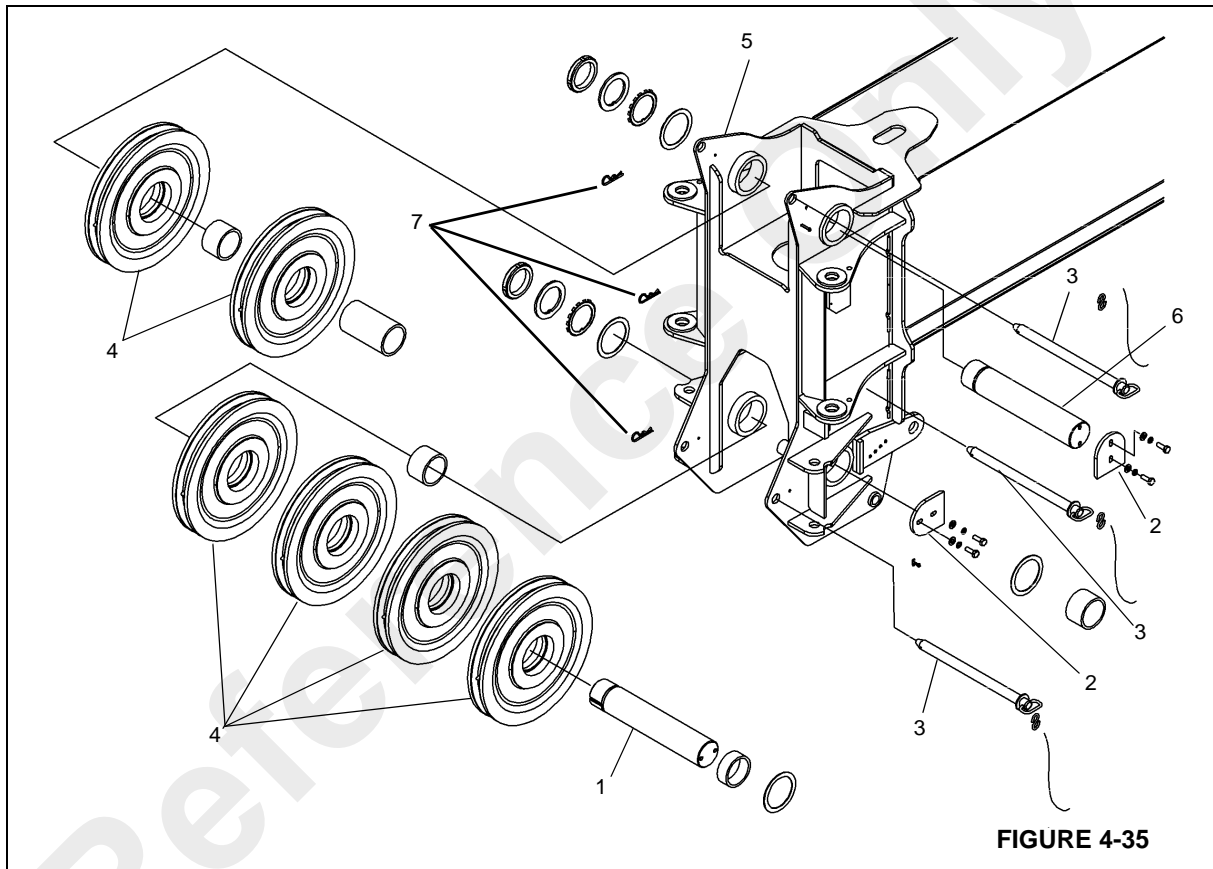

Boom Nose Sheaves Installation

NOTE: The boom nose sheave weighs approximately 17.4 kg (38 lb).

1. Install the spacers and sheaves (Figure 4-35, 4) onto the sheave shaft while installing the sheave shafts into the lower boom nose (Figure 4-35, 5).

NOTE: The lockwasher can be used more than once but must be replaced if not in good condition.

2. Install the lockwasher onto the sheave shaft with the tabs facing out.

3. Install the locknut, washer, keyed washer, and shims (if necessary) onto the boom nose sheave shaft with the chamfer side out. Install the end cap (Figure 4-35, 2) onto the opposite end of the sheave shafts and secure in place with the two bolts.
4. Tighten the locknut until the play in the bearings is eliminated. Bend the lockwasher tabs to secure the locknut in place.
5. Repeat steps 1 through 4 for the upper boom nose sheaves and sheave shaft.
6. Install the cable retainer pins (Figure 4-35, 3) into the upper and lower part of the boom nose and secure in place with the clip pins (Figure 4-35, 7).

BOOM ASSEMBLY PROCEDURE

Do not attempt to work on the boom without experienced supervision.



DANGER

To prevent serious injury or death, always wear personal protective equipment; i.e., a hard hat, eye protection, gloves and metatarsal boots.

Extend Cable Sheave Installation



CAUTION

The extend cable sheave weighs approximately 17.3 kg (38 lb).

NOTE: This procedure can be greatly simplified if two technicians are used. One technician to hold the sheave in place and the other to insert the spacers and sheave shaft.

1. Clean and inspect the sheave assembly shaft bushing. Replace the bushing if damage is found.
2. Lubricate the shaft bushing.
3. Determine the number of spacers required for the sheave shaft.

As many as six spacers (3 on each side) may be required. If you have placed 3 spacers on the first side, and find that only two will fit on the second side, that will be acceptable. It will not be necessary or desirable to remove one spacer from the first side.

4. Apply a light coat of lubricant to the sheave shaft (Figure 4-36, 4).

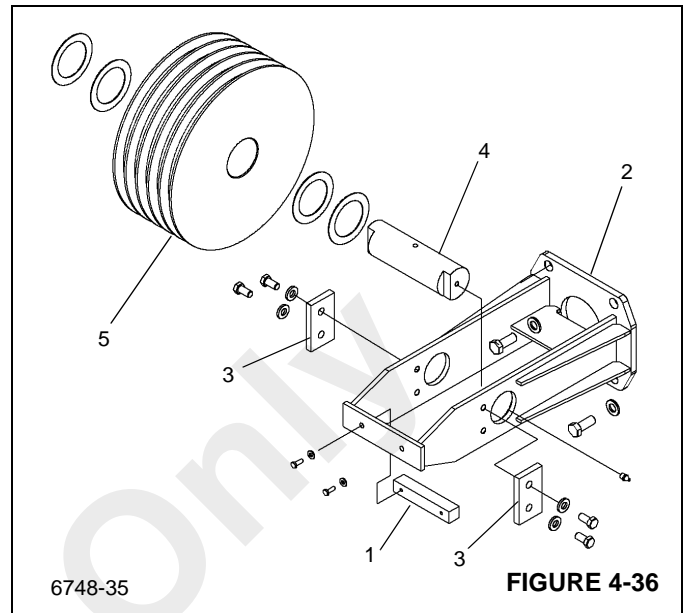

FIGURE 4-36

5. Install the sheave assembly (Figure 4-36, 5), shaft (Figure 4-36, 4) and spacers. Install the shaft with the lubrication fitting to the LEFT and the notches to the Front of the boom.
6. Install the sheave shaft retainer plates (Figure 4-36, 3) on the left and right side with 2 capscrews and 2 washers in each plate.

Install Tele Cylinder

Do not attempt to work on the boom without experienced supervision.



DANGER

To prevent serious injury or death, always wear personal protective equipment; i.e., a hard hat, eye protection, gloves and metatarsal boots.

NOTE: Apply Loctite 243 to the threads of all attaching hardware except cable ends and cable lock nuts.

Apply multipurpose grease (MPG) to all wear surfaces.

Use standard torque values specified in Section 1 of this Manual unless otherwise specified.

NOTE: Wear Pads. When installing upper and lower side wear pad, use shims as necessary so wear pad is within 1.52 mm (0.06 inch) from side plate of next inner section. Use equal number of shims on each

If wear pad shims were previously removed, place shims in same locations that was noted during removal.

1. Measure and mark the center line of the Fly Section. This mark will be used to set the adjustable wear pads after the section is installed in the Outer Mid Section.
2. Install the lower rear side wear pads (Figure 4-37, 1) and shims on the fly section with two screws each.

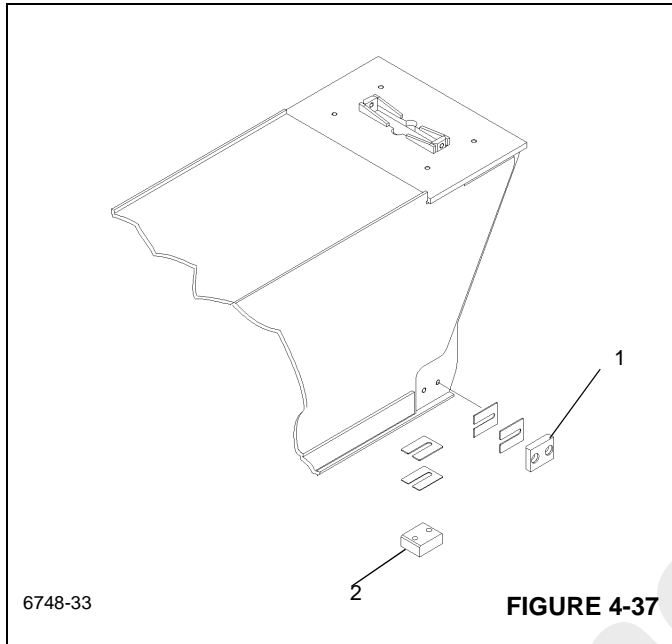

5. Attach a suitable lifting device to the Tele Cylinder. Raise the Tele Cylinder.
6. Position the sheave end of the Tele Cylinder at the rear of the fly section, with port block turned as shown (Figure 4-39).

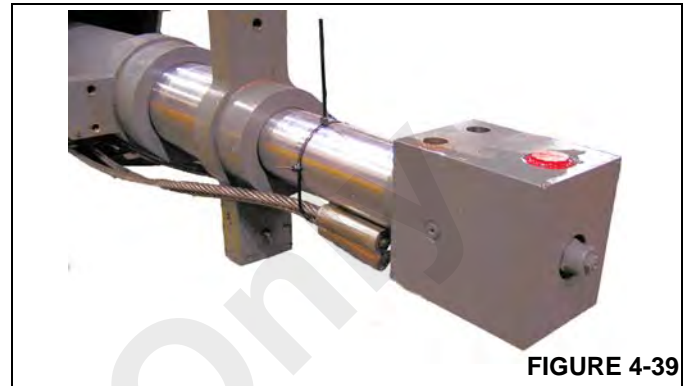

3. Install the bottom rear wear pad (Figure 4-37, 2) on the fly section with two screws.
4. Install the Tele Cylinder Sheave Mount and sheave assembly (Figure 4-38, 1) to the Tele Cylinder (Figure 4-38, 2).
 - a. Install the sheave shaft with the grease fitting to left.
 - b. Do not install the cable retainer with hardware (Figure 4-38, 3) until the Extend Cables are reeved around the sheave
 - c. Lubricate the sheave

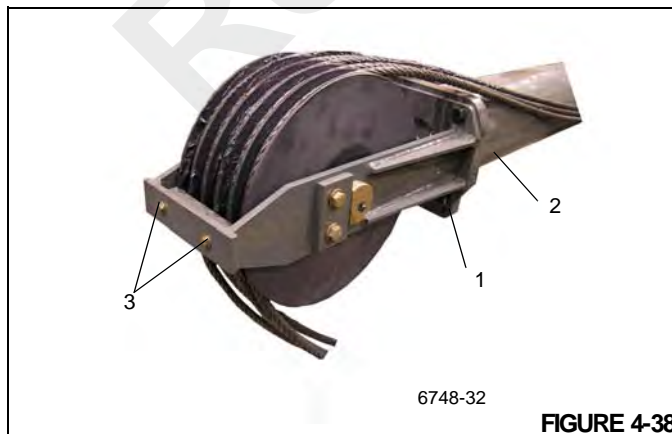

7. Carefully insert the Tele Cylinder into the fly section until the sheave weldment clears the retract cable weldment.
8. Install the two wear pads on the support foot weldment with two bolts each. Torque bolts.
9. Install the cylinder foot weldment (Figure 4-40, 1) to the Tele Cylinder (Figure 4-40, 2) using two bolts.
10. Lower cylinder so the cylinder foot weldment rests on support foot weldment (Figure 4-40, 3) wear pads.

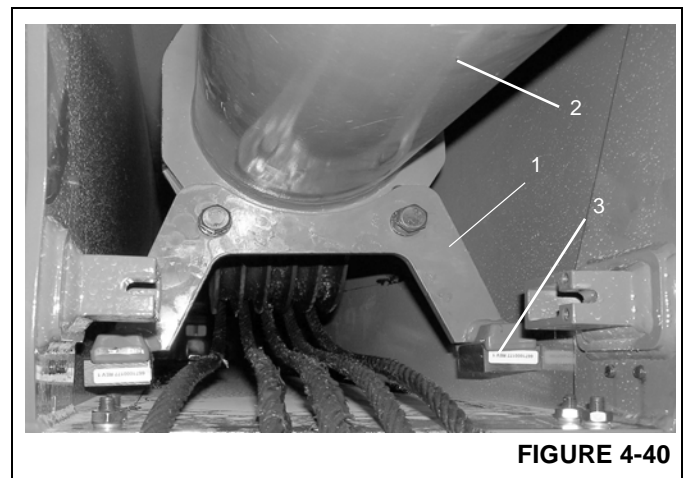

CAUTION

The five Extend Cables must be marked at both ends prior to installation. If the cables are not marked, they will be difficult to install in the correct order.

Do not allow the cables to become entangled or overlap. Cable or boom failure could result.

11. Mark **BOTH ENDS** of the five extend cables (Figure 4-41).

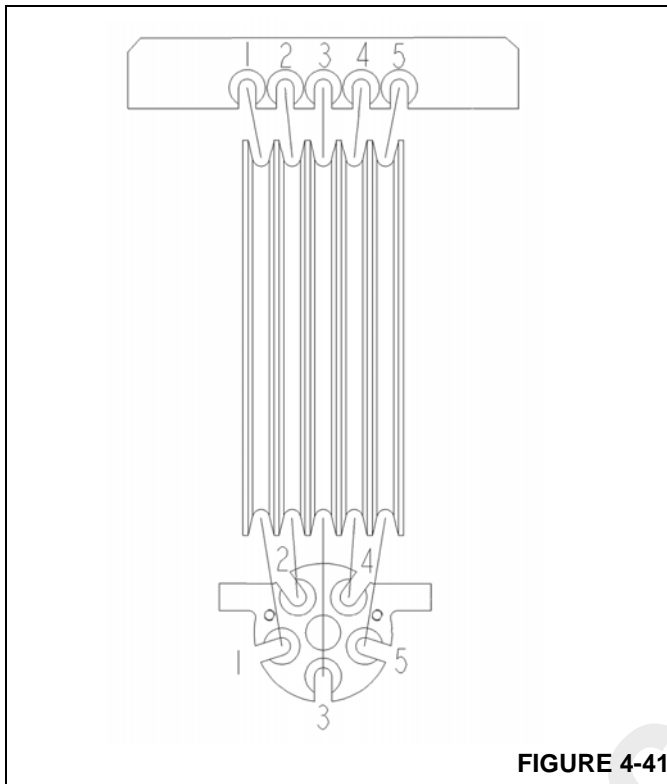

FIGURE 4-41

**CAUTION**

When adjusting cables, hold the cable end and turn the nut. do not turn cable.

Turning or twisting of the cable while adjusting will result in damage or failure of cable.

Install cables in their natural untwisted condition.

12. Reeve the five extend cables around the Tele Cylinder sheave.
13. Place the five extend cable dead ends (Figure 4-42, 1) in the slots at the top of the fly section and secure them

with extend cable keeper plate (Figure 4-42, 2) and two bolts.

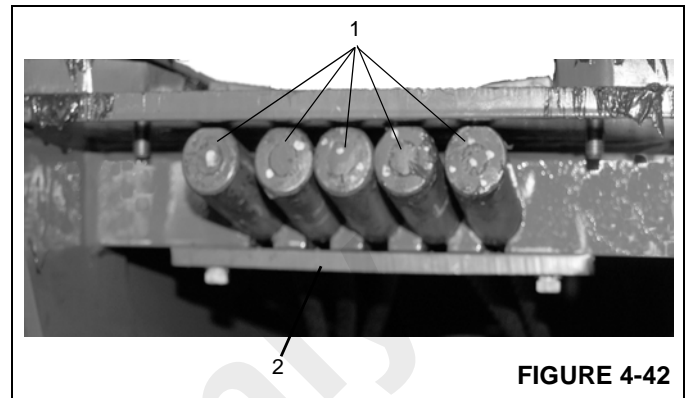

FIGURE 4-42

14. Turn cylinder rod mounting lug ends (Figure 4-43) so they are aligned vertically to clear mounting brackets in the outer mid section.

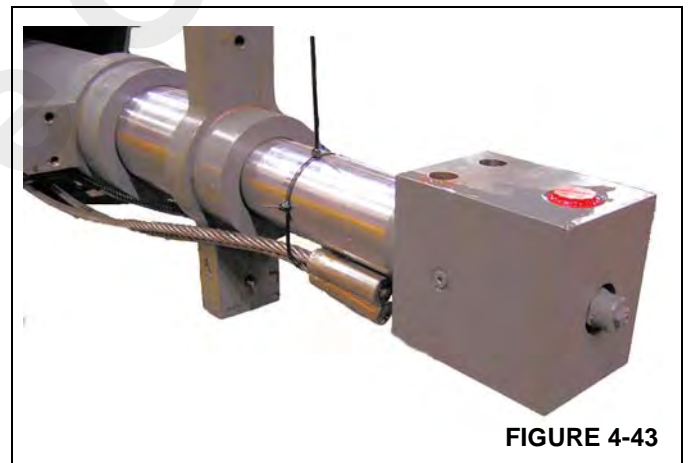

FIGURE 4-43

15. Slide the Tele Cylinder assembly completely into the Fly Section.
16. Inspect the extend cables to ensure that they are not crossed or out of sequence.
17. Place blocking under the rear of the Tele Cylinder to aid in assembly (Figure 4-44).

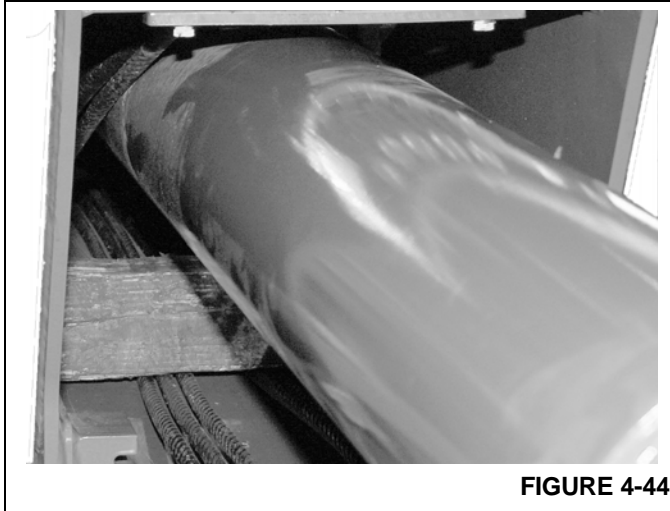

FIGURE 4-44

18. Temporary tie extend cables to the Tele Cylinder to maintain proper cable alignment during assembly (Figure 4-43).

Install the Outer Mid Section

Do not attempt to work on the boom without experienced supervision.



DANGER

To prevent serious injury or death, always wear personal protective equipment; i.e., a hard hat, eye protection, gloves and metatarsal boots.

NOTE: Before the fly section is installed the center point of the fly section must be determined. Measurement from this center point will be used to properly set the adjustable wear pads

1. Align two straight edge tools with the **outer edge of the Fly Section** at the rear of the section (not the wear pad

adjustment weldment). The tools should extend past the wear pad adjustments (Figure 4-45).

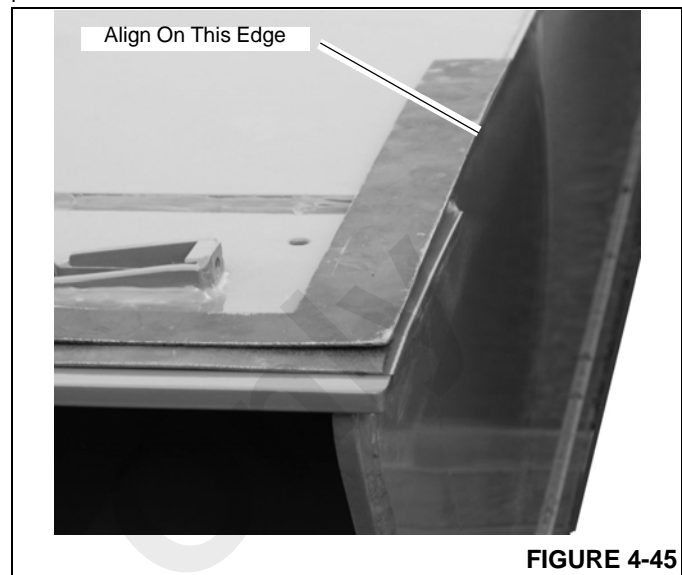

FIGURE 4-45

- a. Measure and note the total width of the boom section.
- b. Using the measurement obtained determine the center point of the boom section and clearly mark it (Figure 4-46).

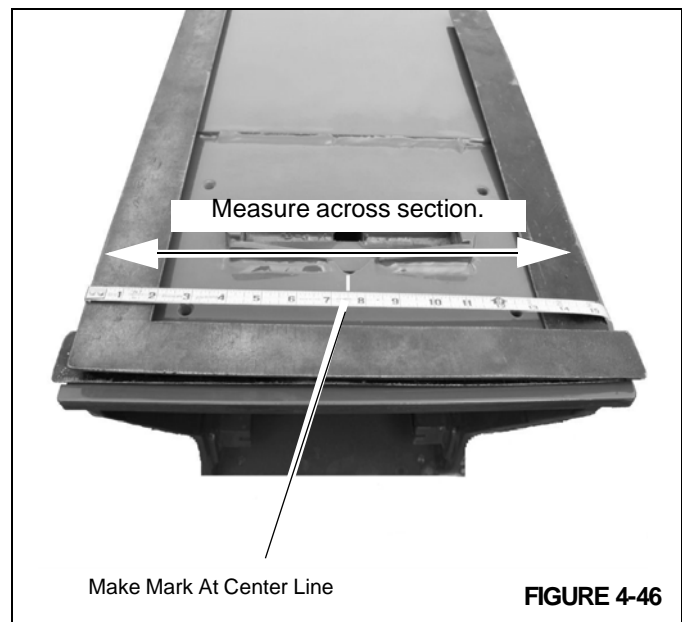

FIGURE 4-46

2. Install the lower (brass) wear pads (Figure 4-47, 1) to the outer mid section. Back out the adjustment set screw so the pad seats fully into the pocket (Figure 4-47, 2). The pad should extend no more than 1/8 of an inch into the outer mid section for the initial installation.

NOTE: Use grease to aid in holding the wear pad in place.

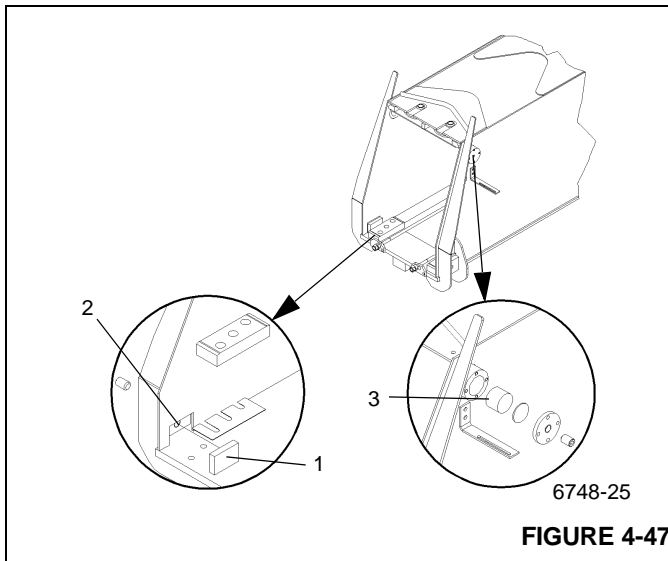

FIGURE 4-47

3. Insert the upper wear pad, backing plate and adjusting plate. (Figure 4-47, 3)
 - a. Attach each wear pad assembly with four washers, four lock washers and four capscrews.
 - b. Insert the hex head adjusting screws. Do not tightened at this time
4. Apply lubricant to the wear pad contact areas of the Fly Section.
5. To aid in the installation of the Fly Section into the Outer Mid Section, apply lubricant to the wear pad contact areas of the Fly Section and secure the Extend Cables to the Tele Cylinder. (Figure 4-48)
 - a. Rotate the Port Block as shown in Figure 4-48.

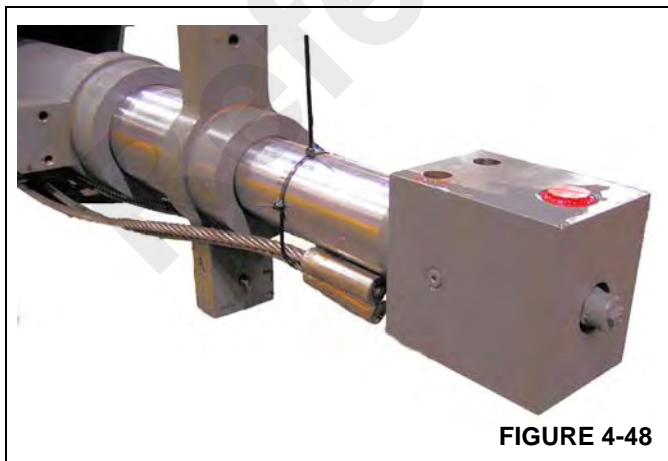

FIGURE 4-48

CAUTION

Do not allow the cables to become entangled or overlap. cable or boom failure could result.

6. Attach the fly retract cables to the cable anchors (Figure 4-49, 1) on the base end of the fly section on both sides. Install the two cable keepers with two lock washers and two bolts on each keeper.
7. Feed the threaded end through outer mid and lay out towards the front of the outer mid section.



FIGURE 4-49

8. Slide the Fly section into the Outer Mid section until the wear pad adjustment is accessible through the access plate on top of the Outer Mid section.

CAUTION

Pull the two fly retract cables through the outer mid as the fly section is being installed. Do not allow the cables to become entangled or overlap. Cable or boom failure could result.

9. Raise the Fly Section slightly and insert the bottom wear pad in to place and secure with retaining bolts. Insert the bolts (Figure 4-50, 1) from the bottom of the Outer Mid Section.

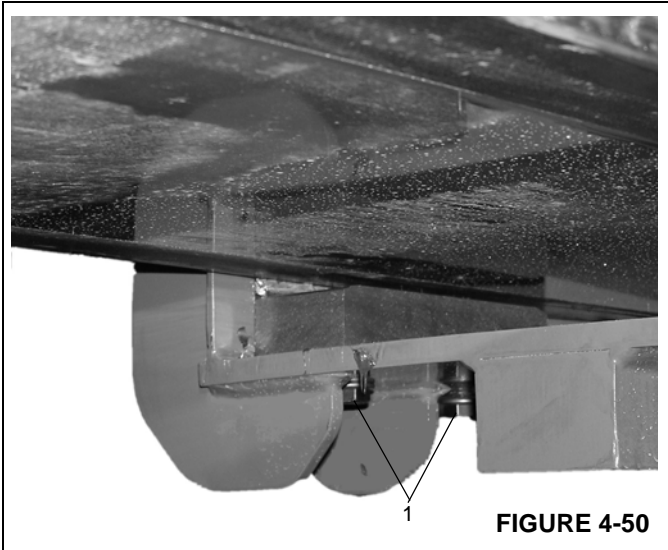

FIGURE 4-50

10. Insert the wear pads and pad holders (Figure 4-51, 1) on the left and right side of the Fly section.

NOTE: The “buttons” on the wear pads may be “shaved down” if needed. Do not cut into the wear pad.

11. Measure and adjust the wear pads until the Fly section is centered $\pm 1\text{mm}$ (± 0.04 inch) in the Outer Mid section. Apply Loctite and tighten jam nut (Figure 4-51, 2).

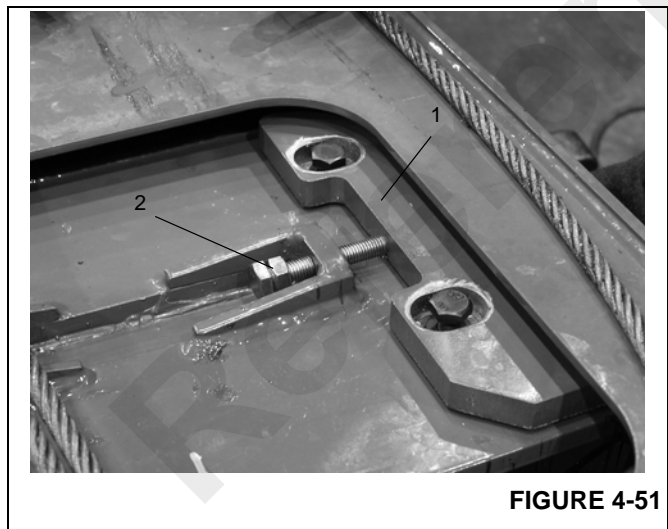

FIGURE 4-51

CAUTION

Do not allow the cables to become entangled or overlap. Cable or boom failure could result.

12. Slide the Fly section the rest of the way into the Outer Mid section.

13. Align cylinder mounting holes with mounting bracket holes in rear of Outer Mid section and secure with two bolts and bushings on each side. (Figure 4-52)

NOTE: It is important that the cylinder mount bolts be properly torqued. The correct torque will allow the cylinder to “float” in the mount.

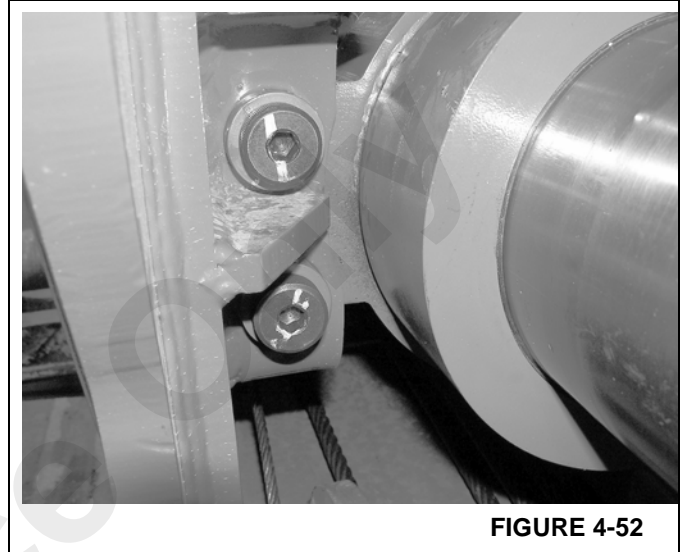

FIGURE 4-52

14. Remove the block of wood holding the Tele Cylinder.
15. Route the fly retract cables down through the bottom of the Outer Mid section. Lay the cables out toward the nose end of the Outer Mid section.
16. Reeve the fly retract cable around the fly retract cable sheave (Figure 4-53, 1) and install in the angled slots (Figure 4-53, 2) on each side of the Outer Mid section.

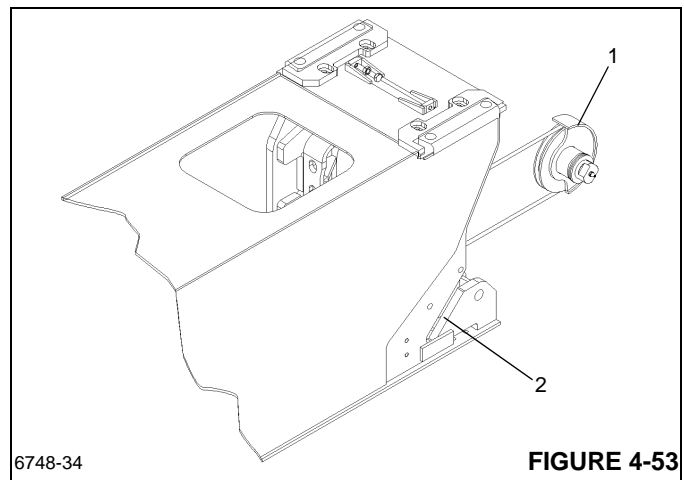

FIGURE 4-53

17. Lubricate Retract Cable shaft.
18. Install kickback plate with hardware (Figure 4-54, 1) on inside top of Outer Mid section.

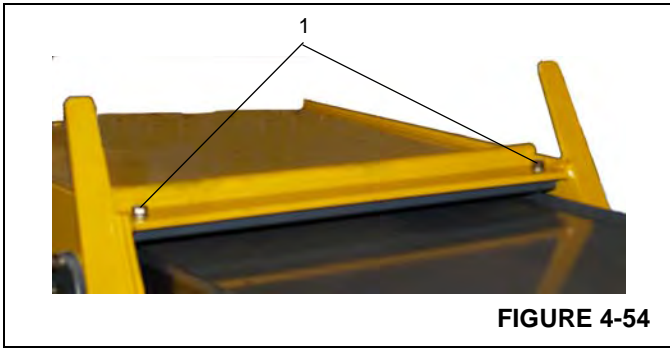

FIGURE 4-54

19. Rotate cylinder mounting to facilitate mounting in to the Inner Mid section. (Figure 4-55)

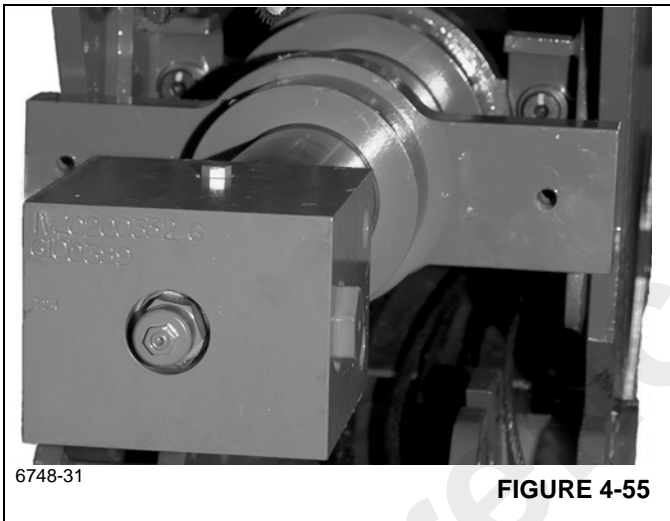

FIGURE 4-55

20. Install Extend Cables in to the round keeper plate (Figure 4-56 and Figure 4-57).

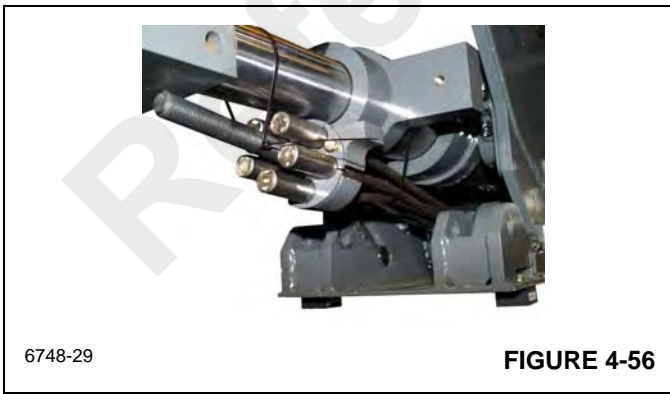

FIGURE 4-56

CAUTION

Install Extend Cables in proper sequence. Do not allow the cables to become entangled or overlap. Cable or boom failure could result.

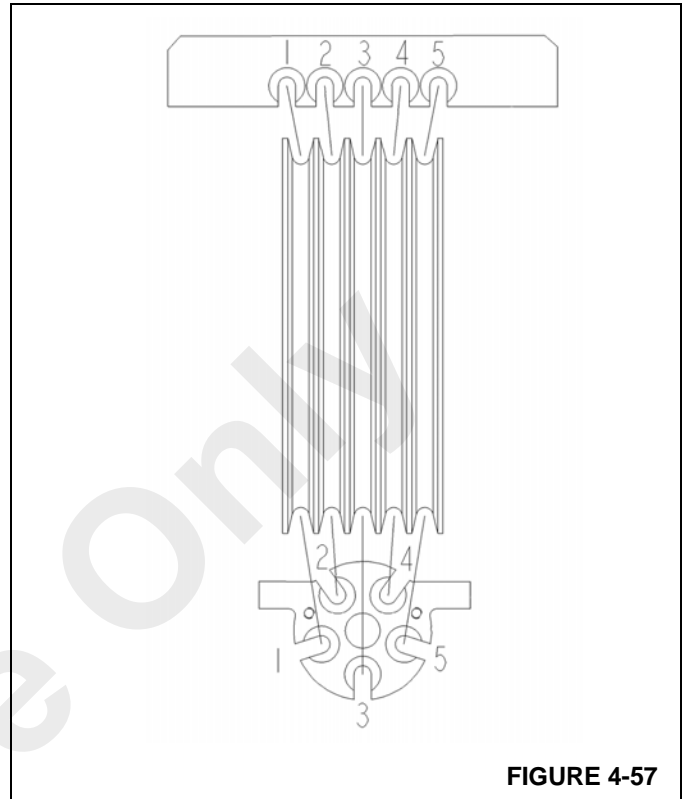

FIGURE 4-57

21. Install adjusting (Figure 4-58) bolt to the anchor assembly.

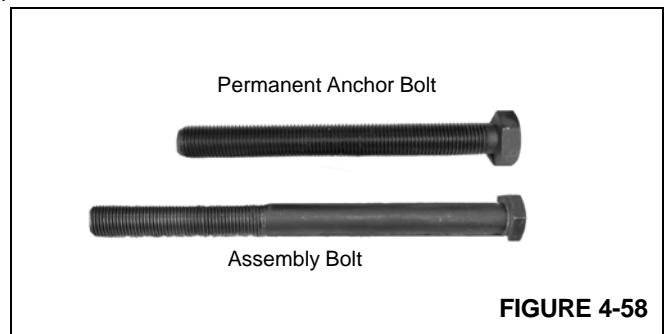

FIGURE 4-58

22. Temporary secure anchor assembly to the Extend Cylinder Rod.

23. Attach the mid retract cables to the anchor point at the base end of the Outer Mid.

a. Lubricate and install pin through cable ends. Secure pin (Figure 4-59, 1) with cotter keys.

24. Lay out the threaded end of the mid retract cables through the Inner Mid section toward the base end.

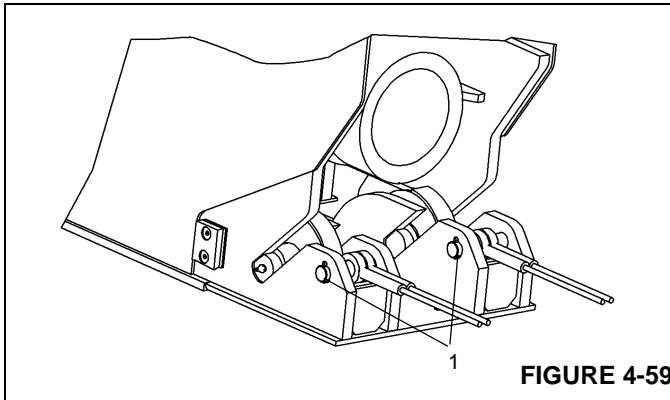

FIGURE 4-59

Install the Inner Mid Section

Do not attempt to work on the boom without experienced supervision.



DANGER

To prevent serious injury or death, always wear personal protective equipment; i.e., a hard hat, eye protection, gloves and metatarsal boots.

1. Insert the adjustable brass wear pads (Figure 4-60, 1) and the upper wear pads (Figure 4-60, 2). Do not install the bottom wear pads at this time.

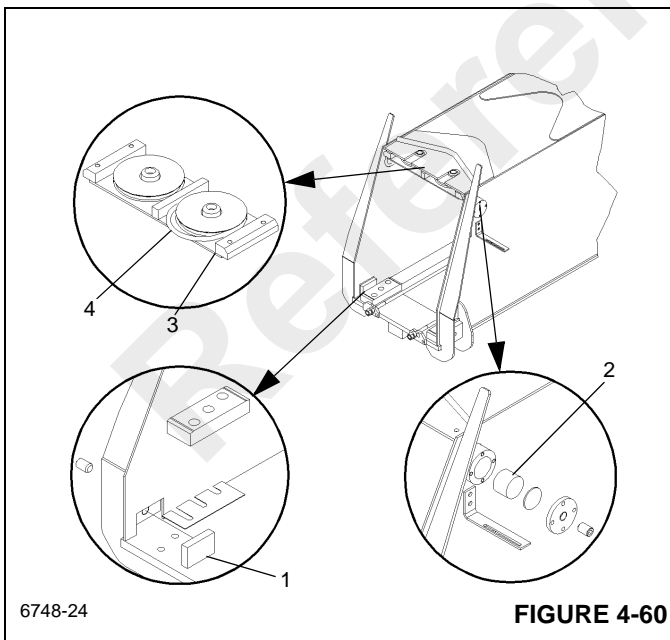

6748-24

FIGURE 4-60

2. Attach both mid syncro cable anchor ends (Figure 4-61, 1) with capscrews and bushings to the base end of the Outer Mid section.

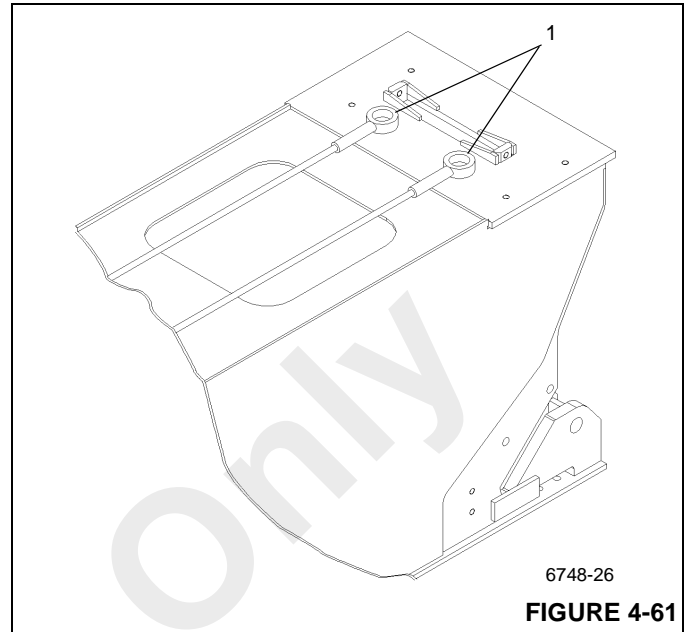

6748-26

FIGURE 4-61

3. Assemble the mid syncro cable sheave assembly (Figure 4-60, 3) and lay on top of the Outer Mid section about where it will go.
 - a. Reeve the mid syncro cables (Figure 4-60, 4) around the sheaves.
 - b. The cables should be reeved from the cable anchor around the outside of the sheave wheels to the inside of the sheave wheels. The threaded end of the cable should be laid out down the center of the Inner Mid section toward the base end.
4. Attach the fly retract cables button ends to the cable anchor points (Figure 4-62, 1) in the Fly Section. Use one keeper plate (Figure 4-62, 2), two cap screws, and two washers on each anchor to secure the cables.



FIGURE 4-62

5. Pass the threaded end of the fly retract cables down through the bottom of the fly section. Lay the cables out toward the nose end of the fly section.
6. Reeve the each fly retract cable around the retract sheaves at the base of the Outer Mid section.

7. Assemble the Fly retract sheave assembly as shown in Figure 4-63 and Figure 4-64. Note that the pin has one thrust washer to the inside of the boom and two thrust washers to the outside of the boom.
8. Lubricate both sheave assemblies

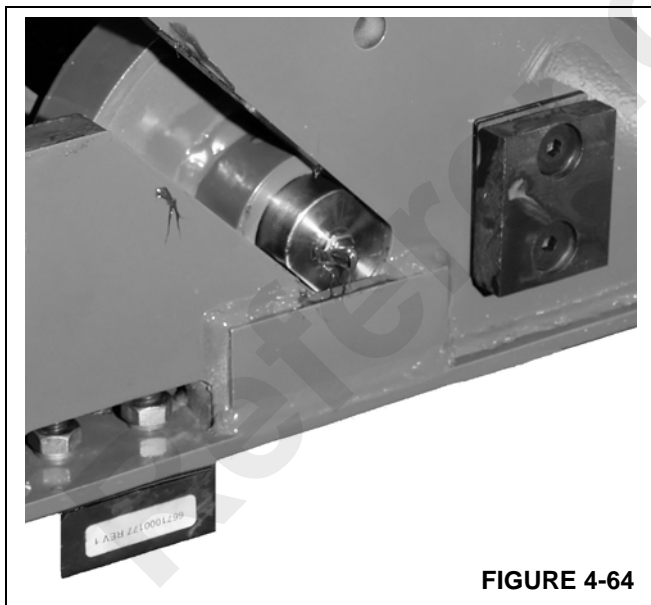
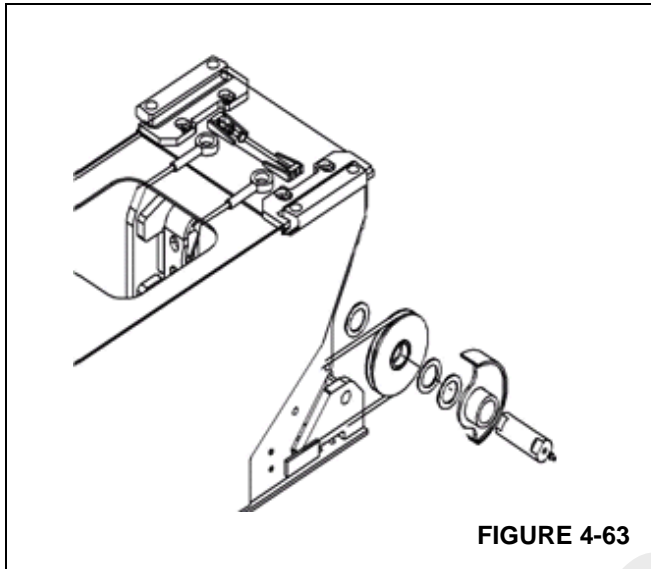

9. Install the rear bottom and side and brass wear pads. Install shims with the open end facing the base end of the boom section.
10. Install adjustment bolts and lock nuts to the upper adjustable wear pad weldment. Do not install wear pads at this time (Figure 4-65).

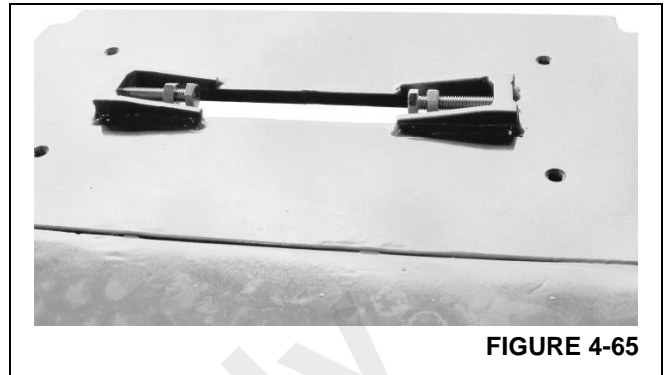

NOTE: Installation of the Extend Cable Anchor Assembly will require the use of a bolt longer than the permanent bolt. The weight of the five extend cables and anchor assembly will make the installation of the anchor assembly extremely difficult with out use of a longer bolt Figure 4-66.

Use bolt Part Number 7099000555 (or equivalent) for installation only (Figure 4-66).

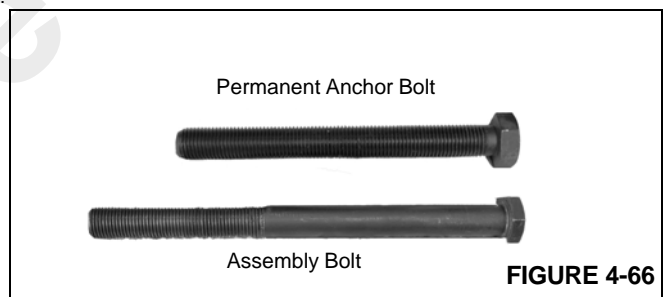

11. Insert assembly bolt into extend cable anchor.
12. Tie the extend cable anchor assembly to the Tele Cylinder (Figure 4-67).

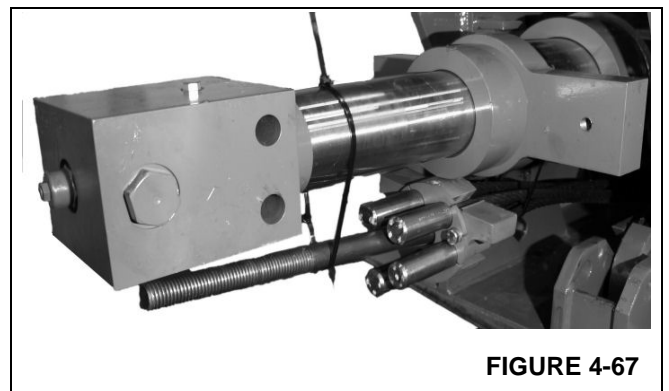

13. Assemble the Fly Retract Cable anchor weldments to the retract cables. Thread the single nut on the cable end until there is 1 1/2 inch of thread showing, then install the locknut (Figure 4-68).

NOTE: There are left and right anchors. Check to make sure the anchors are in the correct position

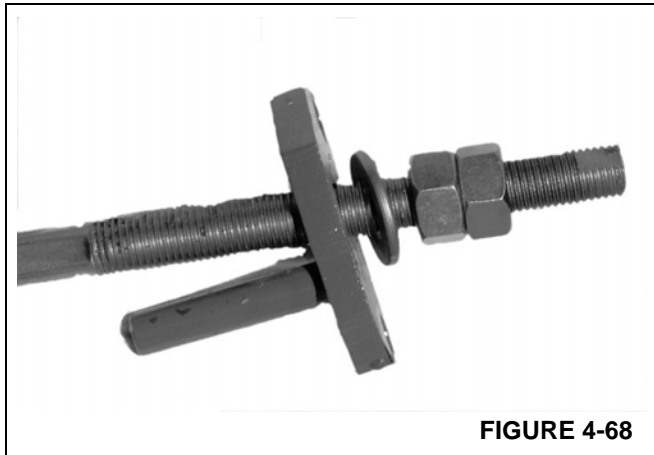

FIGURE 4-68

14. Install the brass wear pad (Figure 4-69, 1) at the nose end of the Inner Mid section.

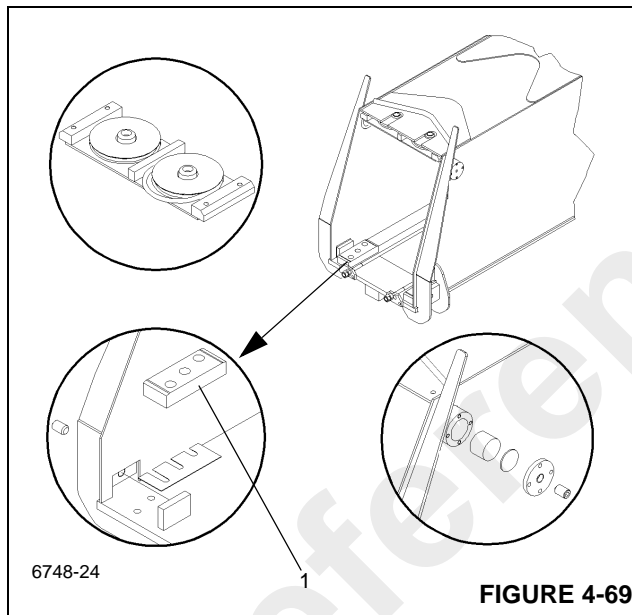

FIGURE 4-69

15. Pull the outer mid retract cables through the Inner Mid section with the threaded end towards the base end of the section.

NOTE: Always lay out and inspect the cables before installation. Laying out cables will help eliminate twists, kinks and make inspection easier.

16. Apply grease to those parts of the inner mid and outer mid where the wear pads will contact.

17. Attach the mid retract cables to the Outer Mid section. (Figure 4-70).

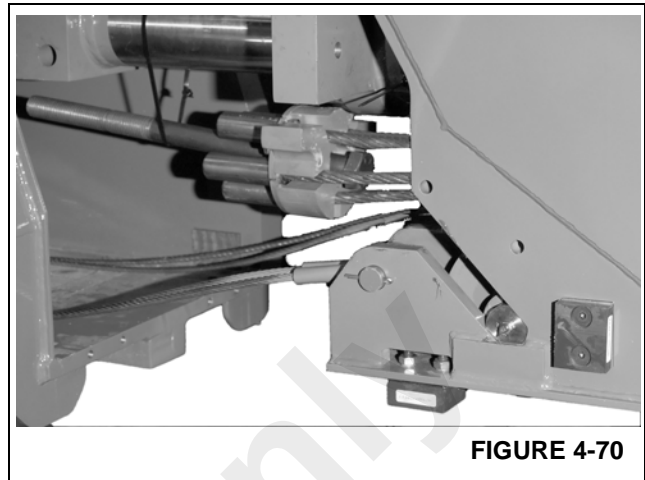
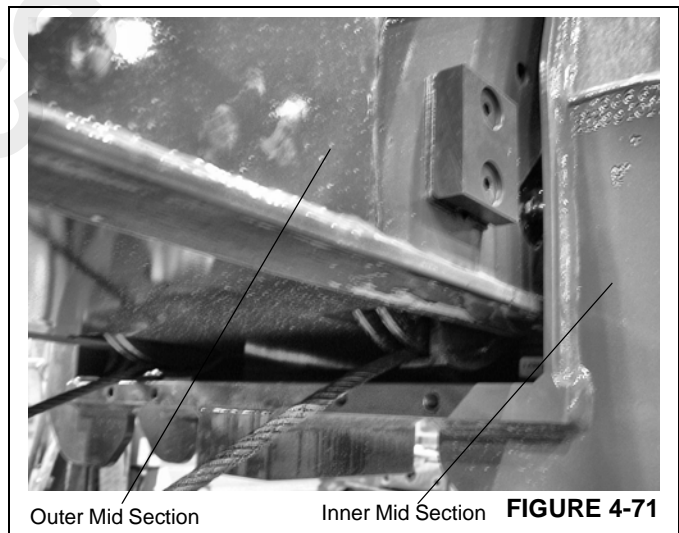

FIGURE 4-70

18. Align the Outer Mid section with the Inner Mid section. Slide sections together (Figure 4-71) until side wear pads on the Outer Mid section engage with the Inner Mid section. Measure clearance at pads and shim as required.



Outer Mid Section Inner Mid Section FIGURE 4-71

NOTE: Pull the Mid Retract Cables through the Base Section as the sections are joined.

CAUTION

Do not allow the cables to become entangled or overlap. Cable or boom failure could result.

19. Insert bottom wear pads on the Inner Mid section.

20. Attach fly retract cable anchors to the nose of the inner mid section (Figure 4-72, 1).

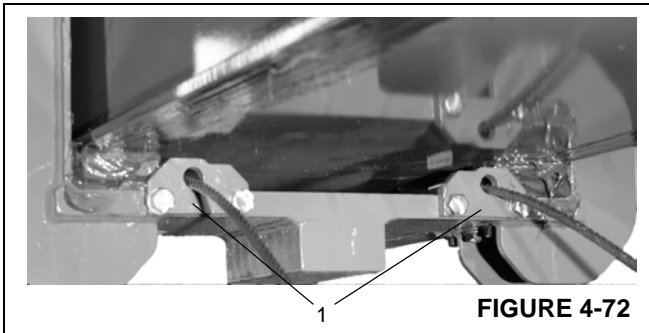

FIGURE 4-72

21. Continue inserting the Outer Mid section in the Inner Mid section. Stop when the upper rear adjustable wear pads on the Inner Mid section are accessible.
22. Install the adjustable wear pads (Figure 4-73, 1) to the top of the base end of the Inner Mid section.

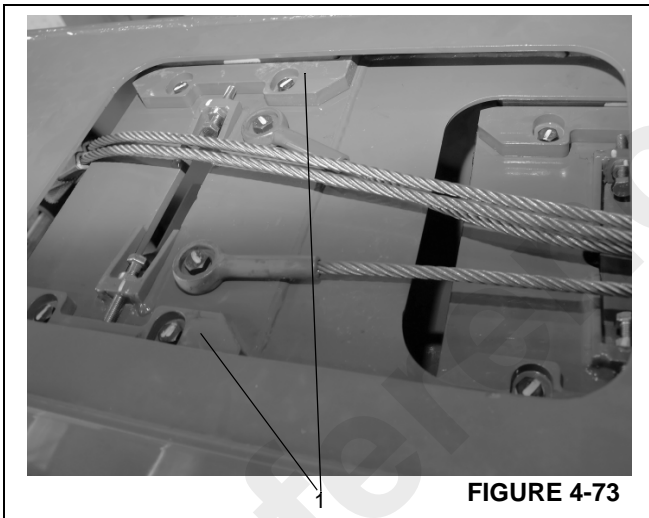

FIGURE 4-73

23. Install kickback plate on inside top Inner Mid section (Figure 4-74, 1).
24. Install the mid syncro cable sheave assembly (Figure 4-74, 2) to top inside of Inner Mid section.

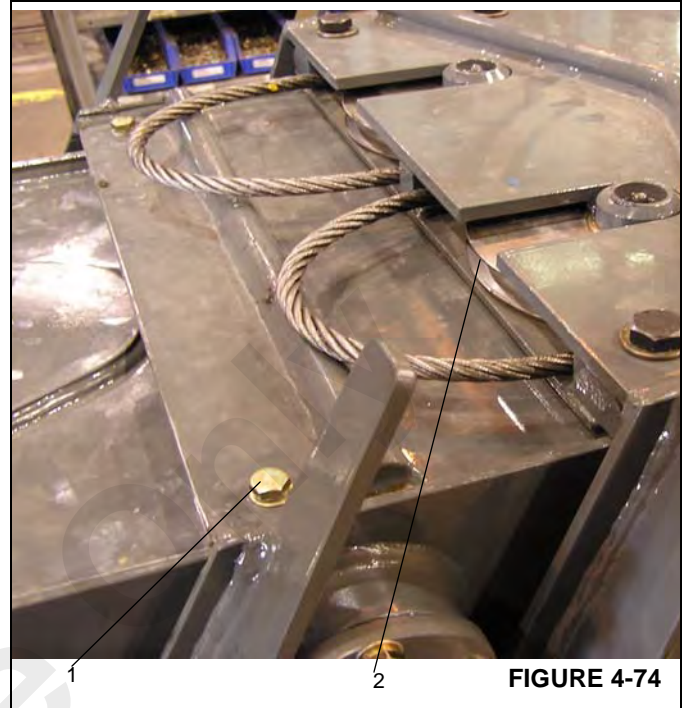

FIGURE 4-74

25. Check to make sure the long cable installation bolt (Figure 4-75, 1) is installed in the extend cable anchor assembly.

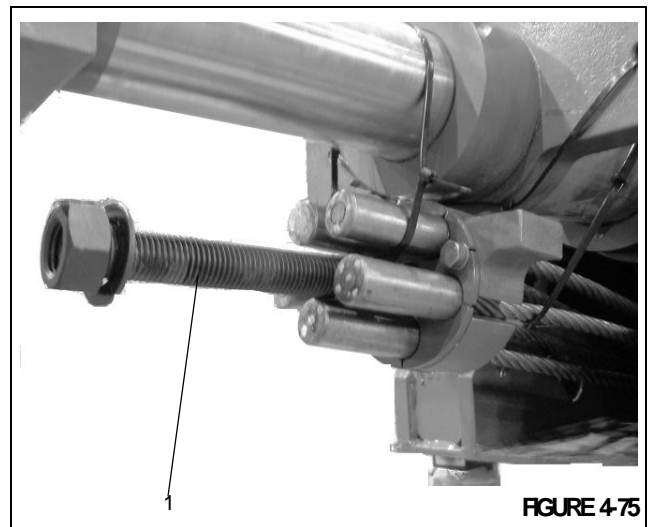

FIGURE 4-75

26. Insert the installation bolt into inner mid anchor weldment and take up as much slack as possible.

NOTE: Make certain that the extend cable anchor is seating properly into the boom section weldment. The “ears” on the anchor must fit into grooves machined into the sides of the inner mid anchor plate.

27. Carefully clamp the anchor assembly to the Inner Mid anchor weldment (Figure 4-76).
- Remove the installation bolt and replace with the standard adjustment bolt.
 - Take up the slack on the anchor adjustment bolt and remove the clamps.

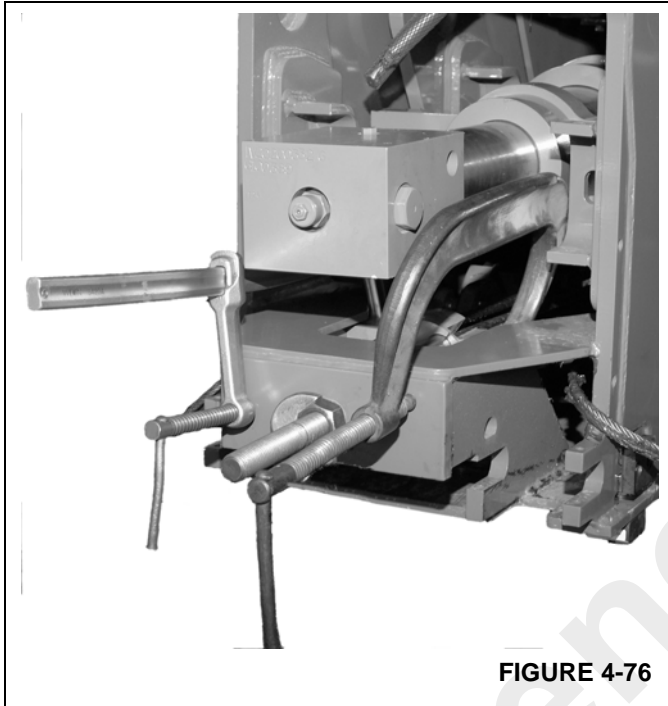

FIGURE 4-76

28. Adjust the adjustment nut until there is 2.75 inches of thread showing. Install jam nut.
29. Attach the Tele Cylinder to the inner mid mounting flanges. Check to ensure bushings are free to rotate after bolts are tightened (Figure 4-77).

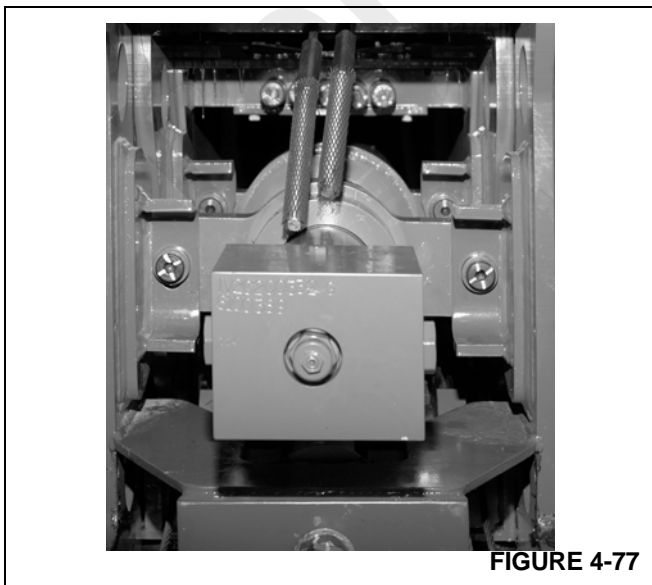

FIGURE 4-77

30. Assemble the mid retract sheave assembly as shown in Figure 4-78 and Figure 4-79. Note that the pin has one thrust washer to the inside of the boom and two thrust washers to the outside of the boom.

NOTE: Insert ONE thrust washer to the INSIDE and TWO thrust washers to the OUTSIDE of each assembly.

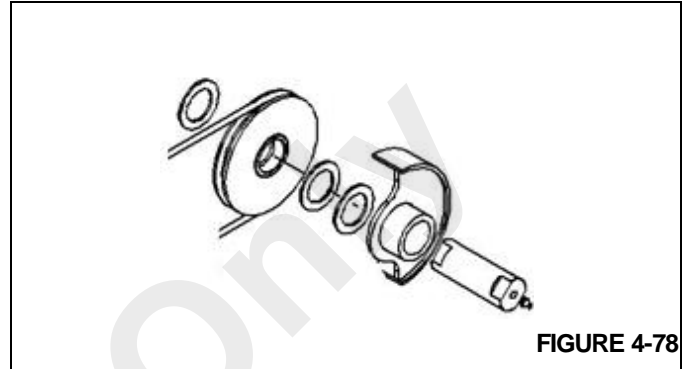

FIGURE 4-78

31. Reeve the mid retract cables on the left and right mid retract cable sheave assemblies and install as shown in Figure 4-78.
32. Install retainer capscrew, washer and nut to lock sheave assembly pins in place (Figure 4-79, 1).

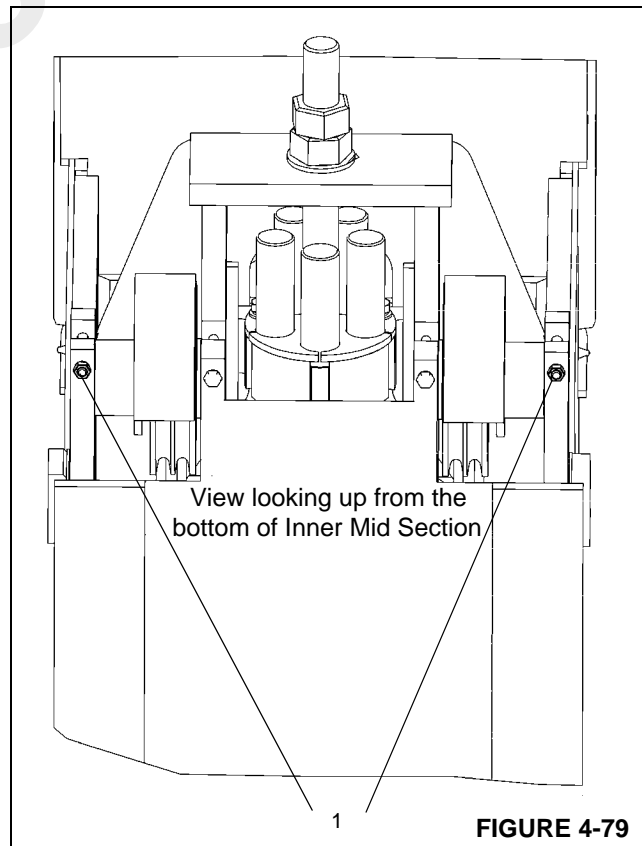

FIGURE 4-79

33. Lay out the mid retract cables toward the nose end of the Inner Mid section.

34. Attach two cables to each anchor adjust each cable to 1.75 inches and install locknuts (Figure 4-80).

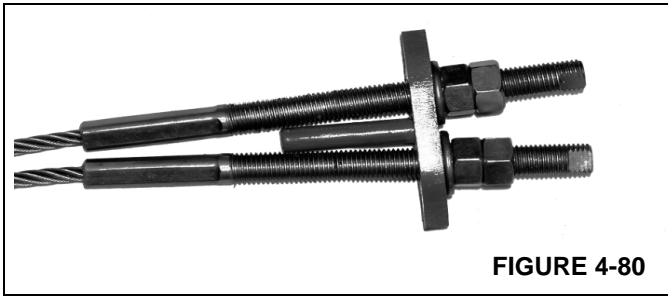

FIGURE 4-80

35. Turn Tele Cylinder port block so that the test port is down (Figure 4-81).

CAUTION

Failure to properly position the port block will cause problems when mounting the boom on the crane. The crane hydraulic system will not function properly if the port block is installed incorrectly.

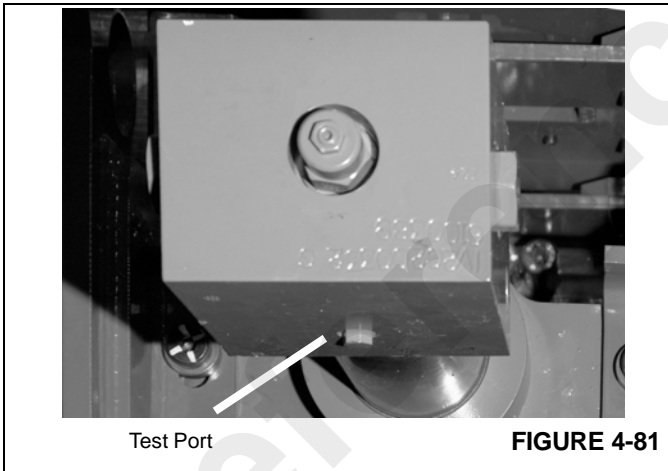

FIGURE 4-81

Install the Base Section

Do not attempt to work on the boom without experienced supervision.



DANGER

To prevent serious injury or death, always wear personal protective equipment; i.e., a hard hat, eye protection, gloves and metatarsal boots.

1. Insert Inner Mid section into the Base section until the Inner Mid section is past the side wear pad access and stop.

2. Install lower front wear pads between sections.

NOTE: Use grease to hold wear pads in place during assembly.

3. Install brass wear pad thru base access hole in side of the Base section and slide Inner Mid section past wear pad and install lock plate (Figure 4-82).

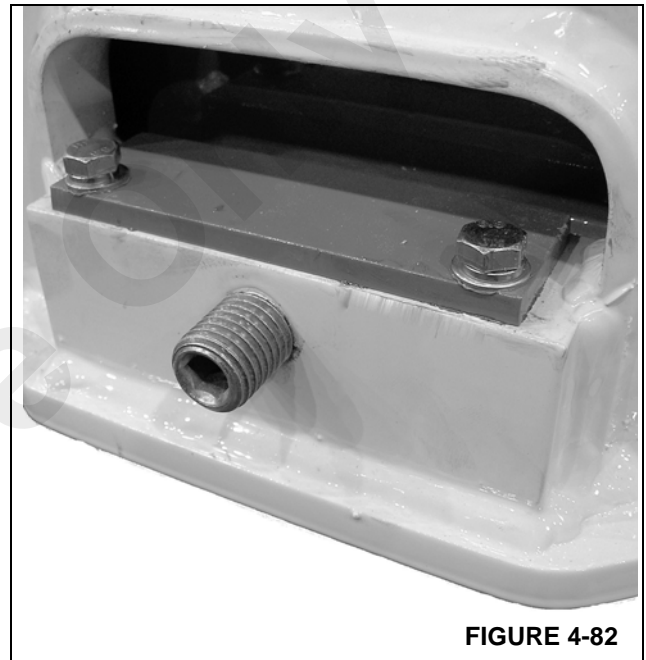

FIGURE 4-82

4. Connect the Mid Retract cables to front end of Base section (Figure 4-83).

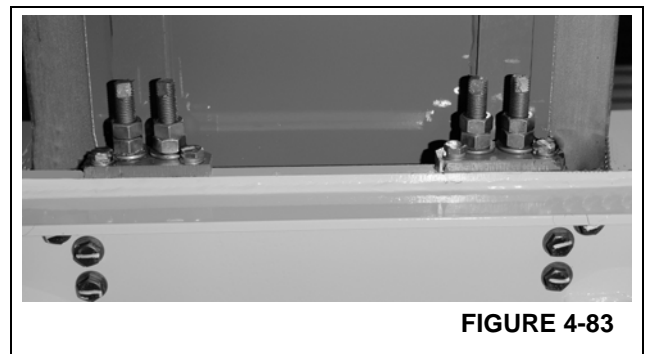

FIGURE 4-83

5. Install kickback bar between the Inner Mid section and the Base section (top front of base).

6. Install top wear pad adjusting assembly inside Base section at top rear access opening (Figure 4-84).



FIGURE 4-84

CAUTION

Ensure the Tele Cylinder Port Block is correctly positioned before proceeding. The boom will not function properly if the Port Block is not installed as shown in Figure 4-85.

CAUTION

There is less than 3mm of clearance between the sides of the weldment and the port block during installation.

Remove any plugs/caps that may interfere with installation.

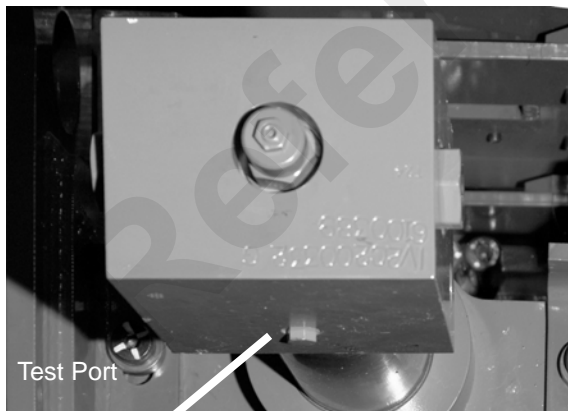

FIGURE 4-85

7. Carefully guide the port block into the anchor weldment.
8. Insert two tele rod end pins. Secure both ends of each pin with a flat washer, lock washer, and capscrew (Figure 4-86).

NOTE: It may be necessary to gently pry the port block to align the pin holes.

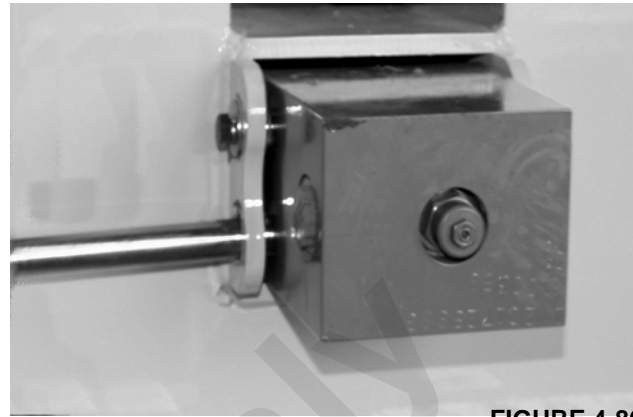

FIGURE 4-86

9. Connect Mid Syncro Cables to rear of Base section.
10. Adjust cable until there is 76mm (3 inch) of threads showing past adjustment nut (Figure 4-87).



FIGURE 4-87

11. Plumb port block with tubing (Figure 4-88).

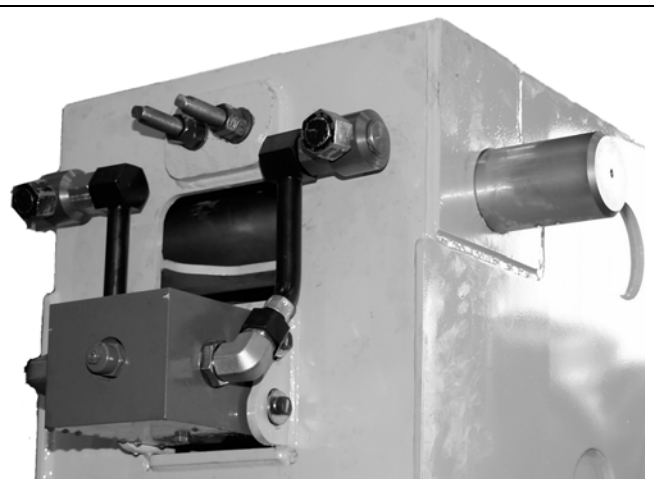
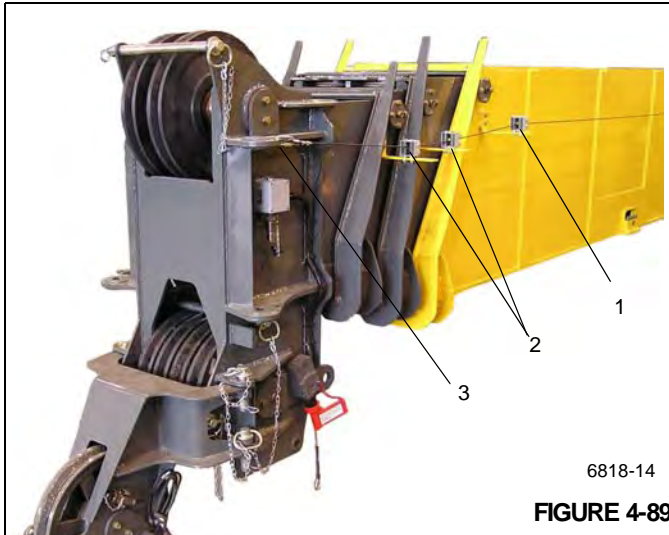
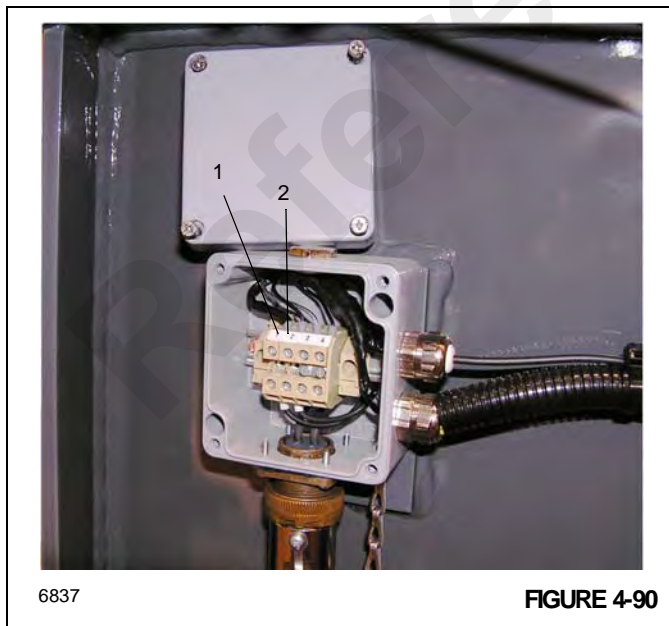

FIGURE 4-88

12. Disconnect RCL, A2B/Cable that was attached to the Base section cable guide (Figure 4-89, 1) in the removal of the boom and feed cable through the Inner and Outer Mid section cable guides (Figure 4-89, 2) and through the Fly section cable guide (Figure 4-89, 3).



13. Remove the RCL, A2B/Cable from boom nose.
- Connect cable connector to side of junction box.
 - Connect "SHD" wire (Figure 4-90, 1) to terminal 1 and "CORE" wire (Figure 4-90, 2) to terminal 2.
 - Replace cover to junction box.



FINAL BOOM ASSEMBLY

Do not attempt to work on the boom without experienced supervision.

DANGER

To prevent serious injury or death, always wear personal protective equipment; i.e., a hard hat, eye protection, gloves and metatarsal boots.

NOTE: The boom may be disassembled with the base section left on the crane if repair of the base section is not necessary.

NOTE: The complete boom assembly weighs approximately 5800 kg (12,740 lb) without the swingaway boom extension attached. Removal of the swingaway boom extension will simplify boom removal.

- Attach a lifting device to the boom to provide for equal weight distribution.
- Raise the boom off of the blocking or cribbing high enough to clear the crane and lower to crane superstructure assembly.
- Align the boom with the superstructure assembly.
- Insert the boom pivot shaft and thrust washers through superstructure assembly and boom.
- Insert the clip pin and retaining pin (Figure 4-6, 1) securing the boom pivot shaft (Figure 4-6, 2) on the boom to the superstructure assembly.

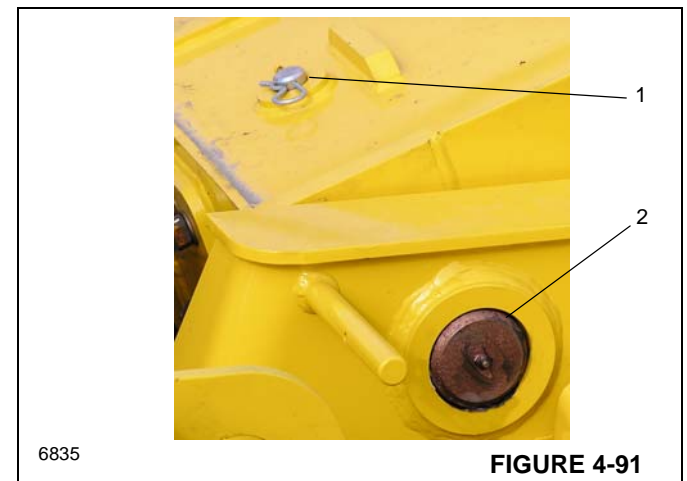

- Install the grease fittings on the pivot shaft and add grease per requirements in LUBRICATION (pg 9-1).
- Remove the hard cap or plugs in the hydraulic lines and openings and connect the hydraulic lines to the telescope cylinder.

8. Connect all electrical wiring to the boom.
9. Elevate the boom slightly with the lifting device so that the lift cylinder can be extended approximately 30.48 cm (12 in) to allow for insertion of the lift cylinder rod end to the lift cylinder lift box on the bottom of the boom.
10. Activate the hydraulic system and extend the lift cylinder rod enough to slide in the lift box (Figure 4-92, 1).

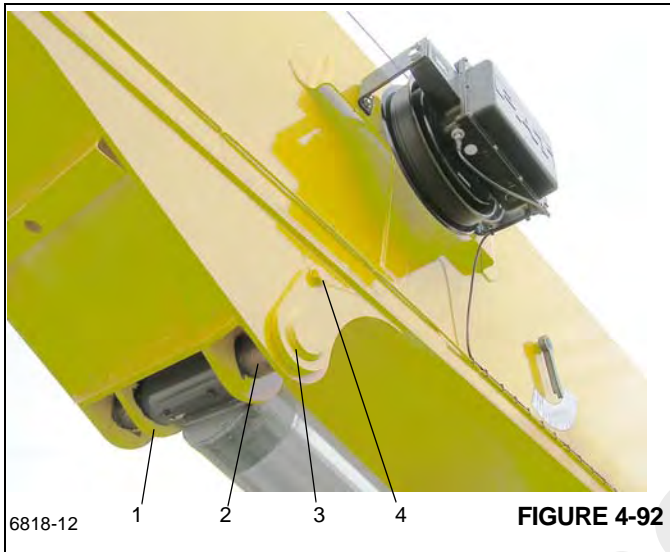

FIGURE 4-92

11. Insert the upper lift cylinder shaft (Figure 4-92, 2).
12. Install the upper shaft weldment (Figure 4-92, 3), bolt (Figure 4-92, 4) and washer to the side of the lift box (Figure 4-92, 1), securing the upper lift cylinder shaft (Figure 4-92, 2) on the boom.
13. Remove the boom lifting device.
14. Ensure the Boom is fully retracted.

DANGER

Wear gloves when handling wire rope.

SWINGAWAY EXTENSION INSTALLATION

DANGER

To prevent serious injury or death, always wear personal protective equipment; i.e., a hard hat, eye protection, gloves and metatarsal boots.

DANGER

Boom angles are used to control speed at which extensions swing during erecting and stowage. Improper boom angles will cause uncontrollable swing speeds of extension.

NOTE: Tag line used in these procedures is to control the movement of the boom extension.

DANGER

Before attempting to remove the boom extension; read and strictly adhere to all danger decals installed on the boom/boom nose, boom extension, and stowage brackets.

1. Crane should be set up on outriggers using normal setup procedures as found in the Operator Manual.
 - a. Fully retract boom.
 - b. Lower boom to horizontal extending over the front of the crane.
2. Attach a lifting device to the lifting lugs on the swingaway extension.
3. Attach a length of rope to the boom extension tip to aid in swinging the boom extension into place ahead of the boom nose.

DANGER

When removing the boom extension, ensure that all personnel and equipment are kept clear of the swing path.

4. Raise the swingaway extension to a safe height to move to the boom and move the extension into place ahead of the boom nose.
5. Using the rope attached to the top of the boom extension, manually align the boom attachment to the boom extension anchor fittings (Figure 4-93, 2).
6. Move the boom slightly up or down to help align the boom attachment and boom extension anchor fittings (Figure 4-93, 2).
7. Insert the right side attachment pins (Figure 4-93, 1) through the boom attachment and boom extension anchor fittings (Figure 4-93, 2). Install the retainer clips in the attachment pins.

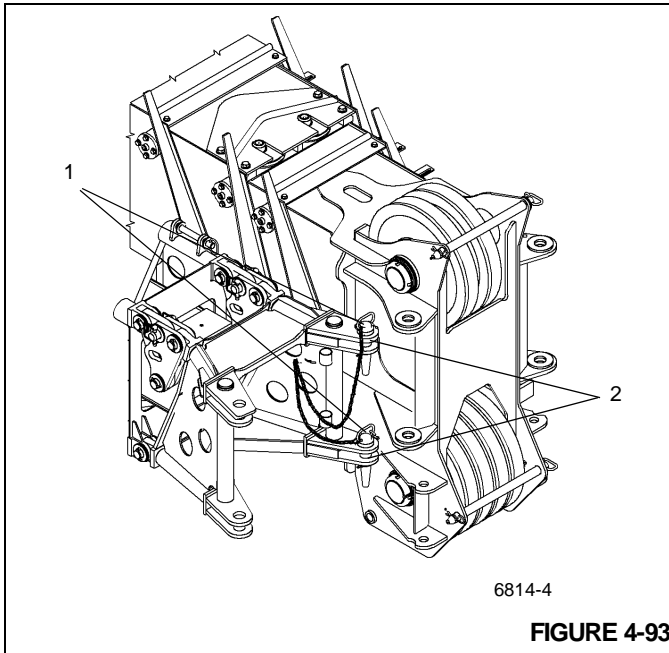

FIGURE 4-93

8. Extend the boom approximately 51 to 64 cm (20 to 25"). Make certain that the boom extension stowage lugs will line up in front of the guide pins (Figure 4-94, 1) and ramp (Figure 4-95, 2) on the stowage brackets when the boom extension is positioned to the side of the boom.

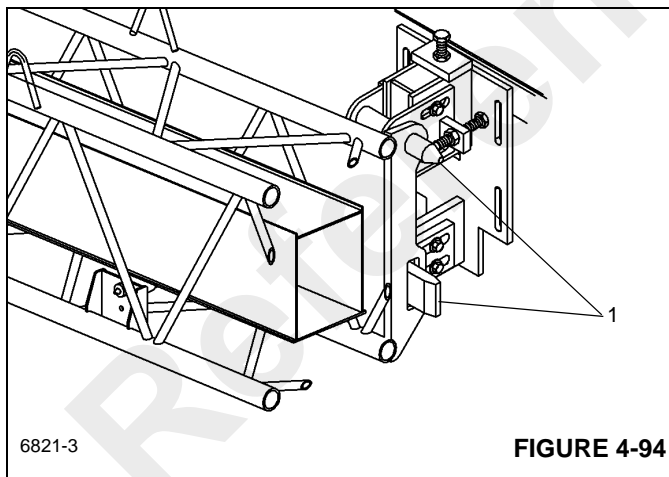

FIGURE 4-94

9. Ensure the hitch pin and clip pin (Figure 4-95, 1) are removed from the rear stowage bracket.

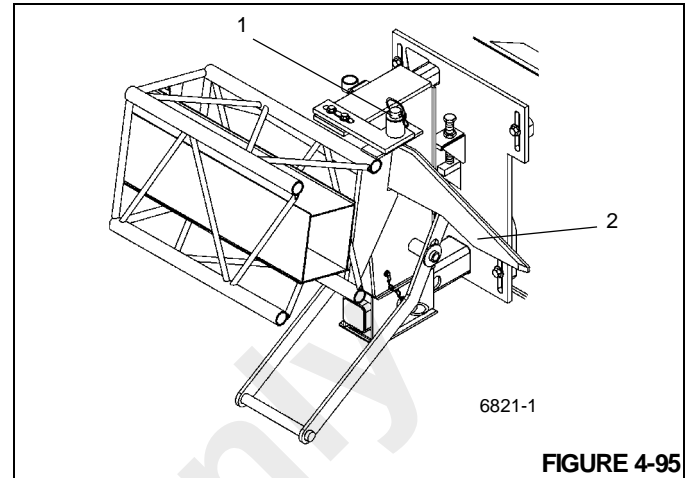

FIGURE 4-95

DANGER

When stowing the boom extension, ensure that all personnel and equipment are kept clear of the swing path.

CAUTION

Do not allow the boom extension to slam into the stowage bracket when swinging into the stowed position.

10. Using the rope attached to the tip of the boom extension, manually swing the extension to the side of the boom.
11. Align the stowage lugs on the boom extension with the guide pins and ramp (Figure 4-95, 2) on the stowage brackets and fully retract the boom.
12. Install the hitch pin and clip pin (Figure 4-95, 1) securing the boom extension to the rear stowage bracket.
13. Remove the attachment pins and clip pins (Figure 4-96, 1) from the anchor and attachment fittings (Figure 4-96, 2) on the right side of the boom nose and stow them in the base of the boom extension. Stow left side attachment pins and clips in outside attachment fitting on swingaway.

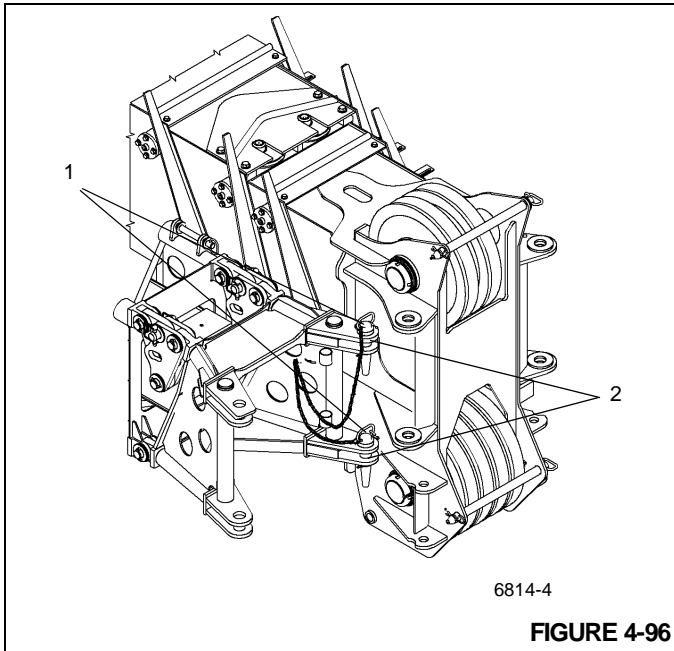

14. On the rear stowage bracket, remove the retainer pin (Figure 4-97, 1) securing the sliding support in the "OUT" position. Push in on the handle (Figure 4-97, 2) to push the swingaway against the rear of the boom
15. Disengage the swingaway anchor fittings from the boom nose attachment lugs. Install the retainer pin (Figure 4-97, 1) securing the sliding support in the "IN" position.

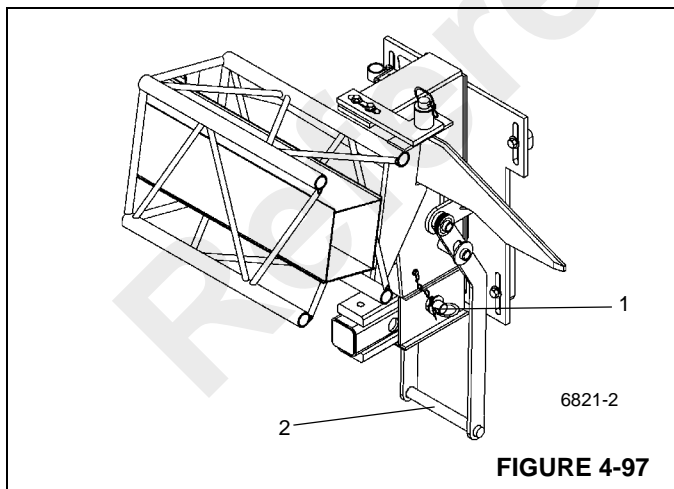

16. Slightly raise and/or lower the boom to help control the boom extension.
17. Rig the boom nose and hoist cable as desired per Section 4 of the RT535E Operator Manual.
18. Align the main and auxiliary hoists to the boom per HOIST AND COUNTERWEIGHT (pg 5-1).
19. Install the hook block or headache ball.

20. Perform all adjustments and maintenance for the boom.

TENSIONING THE BOOM EXTEND AND RETRACT CABLES

The boom extend and retract cables must be tensioned after the boom has been rebuilt and any time the cables appear to be loose.

Tools required:

- 15/16 in, 1-1/4 in, and 1-13/16 in crow's feet
- torque wrench with torque capabilities of 72 in-lb to 360 in-lb

Do the following when tensioning the extend and retract cables:

CAUTION

When adjusting cables, use two wrenches. Hold the "flat" on the cable and turn the adjusting nut.

Do not allow the cables to twist. Cable failure could result.

- When tightening or loosening the cables, secure the cables using the flats at the front of the cable ends to prevent the cables from twisting.
- To assure cables are adequately tensioned, torque cables to at least the minimum torque values found in Table 4-1.
- Ensure all tensioning nuts thread on and off of the threaded studs by hand; weld spalls or thread damage will adversely affect torque values.



WARNING

To prevent serious injury or death, always wear personal protective equipment, including a hard hat, eye protection, gloves and metatarsal boots.

CAUTION

Possible Cable Damage!

Use of an impact wrench to tighten the cable tensioning nuts can cause the extend and retract cables to twist, resulting in cable failure.

Do not use an impact wrench when tensioning the extend and retract cable.

Refer to the following procedures, Figure 4-98, and Table 4-1 when tensioning the extend and retract boom cables:

1. Position the boom to horizontal before making adjustments.
2. Slightly tighten all cables.
3. Fully retract the boom.
4. In the order listed here, tighten the 4/3/2 retract, the 2/3/4 extend, the 3/2/1 retract, and the 1/2/3 extend cables to remove the excess slack from the cables.
5. In the order listed, torque the 4/3/2 retract, the 2/3/4 extend, the 3/2/1 retract, and the 1/2/3 extend cables to the minimum torque values specified in Table 4-1.

To provide better access to adjust the 3/2/1 retract cables, extend the boom approximately 300 mm (12 in), then retract the boom approximately 150 mm (6 in) to tension the cables correctly prior to torques being set.

Fully retract the boom before setting the torque on the 1/2/3 extend cables.

6. Fully cycle the boom.
7. Tighten the extend and retract cables as follows to ensure that all boom sections fully extend and fully

retract simultaneously and that they do not drift out when the hydraulic valve is in neutral.

a. If the 2nd stage is fully retracting late, loosen the 3/2/1 retract cables and tighten the 1/2/3 extend cables. Extend and retract the boom a few feet. Retorque the 3/2/1 retract cables and the 1/2/3 extend cables to verify that the **minimum torque value** is achieved as specified in Table 4-1.

b. If the 3rd stage is fully retracting late, loosen the 4/3/2 retract cables, tighten the 2/3/4 extend cables, then extend and retract the boom a few feet. Retorque the 4/3/2 retract cables and the 2/3/4 extend cables to verify that the **minimum torque value** is achieved as specified in Table 4-1.

8. Ensure that all extend and retract cables achieve the **minimum torque value** as specified in Table 4-1.
9. Add jam nuts and tighten.
10. Coat all stud threads with Never Seize and install cable protectors. All threaded cable ends must be equipped with retainer nuts and jam nuts.

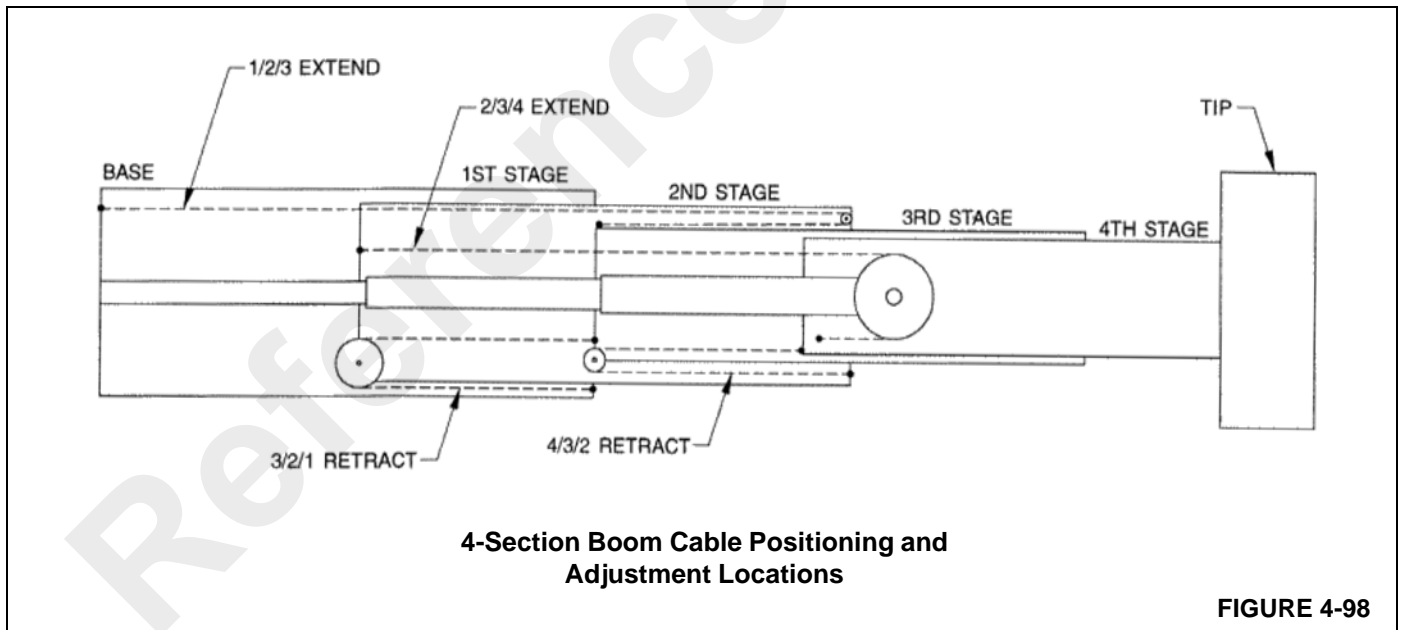

Table 4-1: Minimum Torque Values for Boom Cable Tensioning

Cables (Extend/Retract)	Minimum Torque Values
4/3/2 retract	10.5 Nm (96 in-lb)
2/3/4 extend	40.5 Nm (360 in-lb)
3/2/1 retract	8 Nm (72 in-lb)
1/2/3 extend	16 Nm (144 in-lb)

Note: All above torque values shown are minimums and are calculated with the use of a standard crow's foot attached to the torque wrench in a straight-ahead position.

BOOM MAINTENANCE

Functional Test Of The Boom

1. Activate the hydraulic system and check for proper operation and any leaks.
2. Ensure the boom will extend and retract properly.
3. Ensure the lift cylinder will not allow the boom to drift down until the operator lowers it.
4. Ensure all electrical components disconnected during removal are operating properly.

Boom Inspection

Do not attempt to work on the boom without experienced supervision.



DANGER

To prevent serious injury or death, always wear personal protective equipment; i.e., a hard hat, eye protection, gloves and metatarsal boots.

1. Visually inspect telescoping sections for adequate lubrication of all wear surfaces.
2. Observe extended sections for evidence of cracks, warping, or other damage.
3. Periodically check security of boom wear pads.
4. Check boom nose sheaves for security and freedom of movement.

Boom Alignment And Servicing

Do not attempt to work on the boom without experienced supervision.



DANGER

To prevent serious injury or death, always wear personal protective equipment; i.e., a hard hat, eye protection, gloves and metatarsal boots.

Boom alignment is achieved by adjustment of the wear pads located at various points in the boom assembly. Adjustment of the wear pads is as follows:

1. Fully extend the boom horizontally.
2. Lubricate the boom bottom plates (sides and bottom).
3. Shim the front lower side wear pads to within 1.52 mm (0.06 in) from side plate of next inner boom section, then shim the front upper wear pads in the same manner. Use equal number of shims on each side.

CAUTION

When extending and retracting the boom during alignment, movement should be stopped if a restriction is encountered. re-shim wear pads as necessary to provide free travel of the affected boom section(s).

4. Retract and extend the boom; check for the high point where the boom has brushed the wear pads at the widest point.
5. Retract the boom sections to align the high point on the boom section with the adjacent wear pads.
6. Add or subtract shims as necessary.

Table 4-2

Example	
If the boom deflects to the left:	
1	The forward left wear pad would be shimmed in.
2	The rear left adjustable wear pad would be adjusted out, away from the internal boom section.
3	The forward right wear pad will be shimmed out.
4	The right rear adjustable pad adjusted in

7. Attach a weight and extend the boom full length. Check for side deflection.

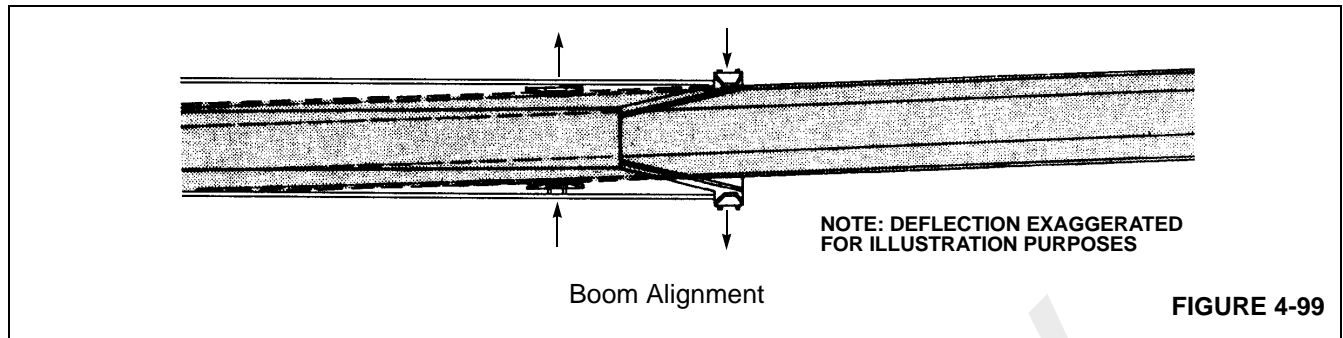

EXTENSION AND RETRACTION CABLE MAINTENANCE

Do not attempt to work on the boom without experienced supervision.



DANGER

To prevent serious injury or death, always wear personal protective equipment; i.e., a hard hat, eye protection, gloves and metatarsal boots.

NOTE: For more detailed information concerning maintenance of the extension and retraction cables, refer to Wire Rope (pg 1-15).

Inspection

Do not attempt to work on the boom without experienced supervision.



DANGER

Never handle wire rope with bare hands. Injury to hands could result.



DANGER

To prevent serious injury or death, always wear personal protective equipment; i.e., a hard hat, eye protection, gloves and metatarsal boots.

The following information is taken from a National Consensus standard as referenced by Federal Government Agencies.

All wire rope will eventually deteriorate to a point where it is no longer usable. Wire rope shall be taken out of service when any of the following conditions exist.

- In running ropes, six randomly distributed broken wires in one lay or three broken wires in one strand in one lay.
- Wear of one-third the original diameter of outside individual wires. Kinking, crushing, bird caging, or any other damage resulting in distortion of the rope structure.
- Evidence of any heat damage from any cause.
- Reductions from nominal diameter of more than:
 - 0.4 mm (0.016-in) for diameters up to and including 8 mm (0.3125-in).
 - 0.79 mm (0.031-in) for diameters 10 and 13 mm (0.375 and 0.5-in) inclusive.
 - 1.19 mm (0.047-in) for diameters 14 to 19 mm (0.5625 to 0.75-in) inclusive.
 - 1.59 mm (0.063-in) for diameters 22 to 29 mm (0.875 to 1.125 in) inclusive.
 - 2.38 mm (0.094-in) for diameters 32 to 38 mm (1.25 to 1.5 in) inclusive.
- In standing ropes, more than two broken wires in one lay in sections beyond end connections or more than one broken wire at an end connection.

TELESCOPE CIRCUIT TROUBLESHOOTING

Table 4-3

SYMPTOM	PROBABLE CAUSE	SOLUTION
1. Erratic operation of extending telescoping cylinder.	a. Low hydraulic oil level.	a. Replenish hydraulic oil to proper level.
	b. Damaged relief valves.	b. Repair or replace relief valves.
	c. Air in telescope cylinder.	c. Bleed by lowering telescope cylinder below horizontal.
	d. Low engine rpm.	d. Increase engine rpm to recommended setting.
	e. Lack of lubrication on boom sections.	e. Properly lubricate all boom sections.
	f. Extremely tight boom extension sheaves.	f. Inspect and properly lubricate boom extension sheaves.
	g. Improper boom alignment caused from side loading.	g. Reduce and properly hoist load.
	h. Worn boom wear pads.	h. Replace wear pads and properly lubricate.
	i. Distorted boom section.	i. Replace distorted section.
	j. Damaged telescope cylinder.	j. Repair or replace cylinder.
	k. Clogged, broken, or loose hydraulic lines or fittings.	k. Clean, tighten, or replace lines or fittings.
l. Damaged control valve.	l. Repair or replace control valve.	
2. Erratic operation of retracting telescoping cylinder.	a. Low hydraulic oil level.	a. Replenish hydraulic oil to proper level.
	b. Damaged relief valve.	b. Repair or replace relief valve.
	c. Air in cylinder.	c. Bleed by lowering telescoping cylinder below horizontal and cycle telescope cylinder.
	d. Low engine rpm.	d. Increase engine rpm to recommended setting.
	e. Lack of lubrication.	e. Properly lubricate all boom sections.
	f. Check valve malfunctioning.	f. Repair or replace check valve.
	g. Improper boom alignment caused from side loading.	g. Reduce and properly hoist load.
	h. Extremely tight boom retraction sheave.	h. Inspect and properly lubricate.
	i. Distorted boom section.	i. Replace distorted section.
	j. Worn boom wear pads.	j. Replace wear pads and properly lubricate.
	k. Bent cylinder rod(s).	k. Replace cylinder rod(s) and all cylinder seals.
	l. Scored cylinder barrel.	l. Repair or replace cylinder barrel.
	m. Damaged piston seals.	m. Replace all cylinder seals.
	n. Loose or damaged piston(s).	n. Replace all seals and re-torque or replace piston(s).

SYMPTOM	PROBABLE CAUSE	SOLUTION
3. Telescope cylinder will not extend.	a. Low hydraulic oil level.	a. Replenish oil to proper level.
	b. Relief valve malfunctioning.	b. Repair or replace relief valve.
	c. Excessive load.	c. Reduce load.
	d. Clogged hose and fittings.	d. Replace hose or fittings. (Refer to Manitowoc Crane Care Parts Manual).
	e. Broken valve spool.	e. Replace valve.
	f. Damaged piston seals.	f. Replace all cylinder seals.
	g. Damaged piston(s).	g. Replace piston(s) and all cylinder seals.
	h. Bent boom section(s).	h. Replace damaged boom section(s).
	i. Broken hydraulic pump coupling.	i. Replace broken hydraulic pump coupling.
	j. Worn or damaged hydraulic pump section.	j. Repair or replace pump section.
4. Telescope cylinder will not retract.	a. Low hydraulic oil level.	a. Replenish oil to proper level.
	b. Relief valve damaged.	b. Repair or replace relief valve.
	c. Excessive load.	c. Reduce load. (Refer to load chart).
	d. Inoperative check valve.	d. Replace check valve.
	e. Clogged hose and fittings.	e. Replace hose or fittings. (Refer to Manitowoc Crane Care Parts Manual).
	f. Broken valve spool.	f. Replace valve section.
	g. Broken piston(s).	g. Replace piston(s) and all cylinder seals.
	h. Damaged piston seals.	h. Replace all cylinder seals.
	i. Bent boom section(s).	i. Replace damaged boom section(s).
	j. Broken hydraulic pump coupling.	j. Replace broken hydraulic pump coupling.
k. Worn or damaged hydraulic pump.	k. Repair or replace pump.	
l. Broken hydraulic pump shaft.	l. Replace pump shaft.	

LIFT CIRCUIT TROUBLESHOOTING

Table 4-4

Symptom	Probable Cause	Solution
1. Boom raises erratically.	a. Low hydraulic oil.	a. Replenish hydraulic oil to proper level.
	b. Low engine rpm.	b. Increase engine rpm to recommended setting.
	c. Main relief valve damaged.	c. Replace relief valve.
	d. Air in cylinder rod.	d. Bleed cylinder rod.
	e. Bent boom pivot shaft.	e. Replace pivot shaft.
2. Boom lowers erratically.	a. Low hydraulic oil.	a. Replenish hydraulic oil to proper oil level.
	b. Low engine rpm.	b. Increase engine rpm to recommended level.
	c. Circuit and/or relief valve inoperative.	c. Repair or replace relief valve.
	d. Air in hydraulic cylinder.	d. Bleed air from cylinder.
	e. Damaged hydraulic pump section.	e. Repair or replace pump section.
3. Boom raises slowly.	a. Low hydraulic oil level.	a. Replenish hydraulic oil to proper level.
	b. Low engine rpm.	b. Increase and maintain engine rpm.
	c. Damaged relief valve.	c. Repair or replace relief valve.
	d. Extremely cold hydraulic oil.	d. Operate unit to bring oil to operating temperature.
	e. Improper hose or fittings, installed.	e. Replace hose or fittings. (Refer to Manitowoc Crane Care Parts Manual).
	f. Operating two functions with in the same control valve bank assembly.	f. Feather controls to obtain desired speed of both functions.
	g. Restriction in return hose.	g. Replace return hose.
	h. Cylinder piston seals leaking.	h. Replace all cylinder seals.
	i. Scored cylinder barrel.	i. Hone or replace barrel.
	j. Worn hydraulic pump section.	j. Repair or replace pump section.
4. Boom lowers slowly.	a. Low hydraulic oil level.	a. Replenish hydraulic oil to proper level.
	b. Low engine rpm.	b. Increase rpm to recommended level.
	c. Damaged relief valve.	c. Repair or replace relief valve.
	d. Operating two functions within the same control valve bank assembly.	d. Feather controls to obtain desired speed of both functions.
	e. Extremely cold hydraulic oil.	e. Operate unit to bring oil to operating temperature.
	f. Improper hose or fittings installed.	f. Replace hose or fittings. (Refer to Manitowoc Crane Care Parts Manual).
	g. Restriction in return hose.	g. Replace return hose.
	h. Cylinder piston seals worn.	h. Replace all cylinder seals.
	i. Scored cylinder barrel.	i. Hone or replace barrel.

Symptom	Probable Cause	Solution
Boom lowers slowly. (Continued)	j. Worn hydraulic pump section.	j. Repair or replace pump section.
	k. Piston rod broken (loose from piston).	k. Replace piston rod and all cylinder seals.
5. Boom will not raise.	a. Low hydraulic oil.	a. Replenish hydraulic oil to proper level.
	b. Main relief valve or circuit relief valve damaged.	b. Repair or replace relief valve.
	c. Excessive load.	c. Reduce load as required.
	d. Worn or damaged hydraulic pump section.	d. Repair or replace pump section.
	e. Broken pump shaft.	e. Replace pump shaft and seals.
	f. Broken pump drive coupling.	f. Replace drive coupling.
	g. Broken control valve spool.	g. Replace control valve.
6. Boom will not lower.	a. Low hydraulic oil.	a. Replenish hydraulic oil to proper level.
	b. Main relief valve or circuit relief valve damaged.	b. Repair or replace relief valve.
	c. Worn or damaged hydraulic pump section.	c. Repair or replace pump section.
	d. Broken pump shaft.	d. Replace pump shaft and seals.
	e. Broken pump drive coupling.	e. Replace drive coupling.
	f. Broken control valve spool.	f. Replace control valve.

LIFT CYLINDER MAINTENANCE

Lift Cylinder Removal

NOTE: Refer to HYDRAULIC SYSTEM (pg 2-1) for lift cylinder disassembly and assembly procedures. Maintenance not requiring removal of the cylinder barrels, such as packing, may be performed without removing the cylinders from the turntable. However, all disassembly and assembly should be conducted in a clean dust-free area.

1. Extend and set the outriggers and level the crane.
2. Elevate the boom slightly so that the lift cylinder is extended approximately 0.3 m (1 ft).



DANGER

The weight of the Lift Cylinder is approximately 578 kg (1275 lb). Ensure that adequate and properly tested lifting devices are used to remove the Lift Cylinder.

3. Ensure the boom is fully supported by placing blocking or cribbing under the boom. Rest the boom on the blocking or cribbing.
4. Remove the bolt and washer securing the lift cylinder upper pivot shaft to the boom (see Figure 4-100).
5. Remove the bolt and locknut securing the lift cylinder lower pivot shaft to the turntable.
6. Attach an adequate lifting/supporting device to the lift cylinder being removed.
7. Remove the upper pivot shaft. Activate the hydraulic system and retract the lift cylinder enough to clear the upper attach point.
8. Tag and disconnect all the hydraulic lines to the cylinder. Cap or plug all openings with high pressure fittings.

9. Pull the lower lift cylinder pivot shaft out far enough to remove the cylinder.

10. Move the lift cylinder to a clean work area.

Lift Cylinder Disassembly And Assembly

Disassembly and assembly procedures of the lift cylinder holding valve, and control valve are provided under Lift Cylinder (pg 2-57), Holding Valves (pg 2-40) and Directional Control Valves (pg 2-6).

Lift Cylinder Installation

1. Attach an adequate lifting device to the lift cylinder and position the cylinder over the attach fitting on the turntable.
2. Lower the lift cylinder into the attach fittings on the turntable and align the lift cylinder bushing with the attach fitting holes.
3. Install lower pivot shaft (Detail B) with tapped hole on the right side, side opposite the cab.
4. Install the lift cylinder lower pivot shaft and secure with the bolt and locknut.
5. Connect the extend and retract hoses to the lift cylinder.
6. Activate the crane's hydraulic system and align the lift cylinder rod end with the attach point on the boom. Install the upper pivot shaft through the cylinder and boom attach points. Shut down the engine.
7. Secure the upper pivot shaft with the bolt and washer.
8. Remove the lifting and supporting devices from the boom and lift cylinders. Activate the hydraulic system and check the lift cylinders for proper operation and any leaks.
9. Lubricate the pivot shafts using grease fittings

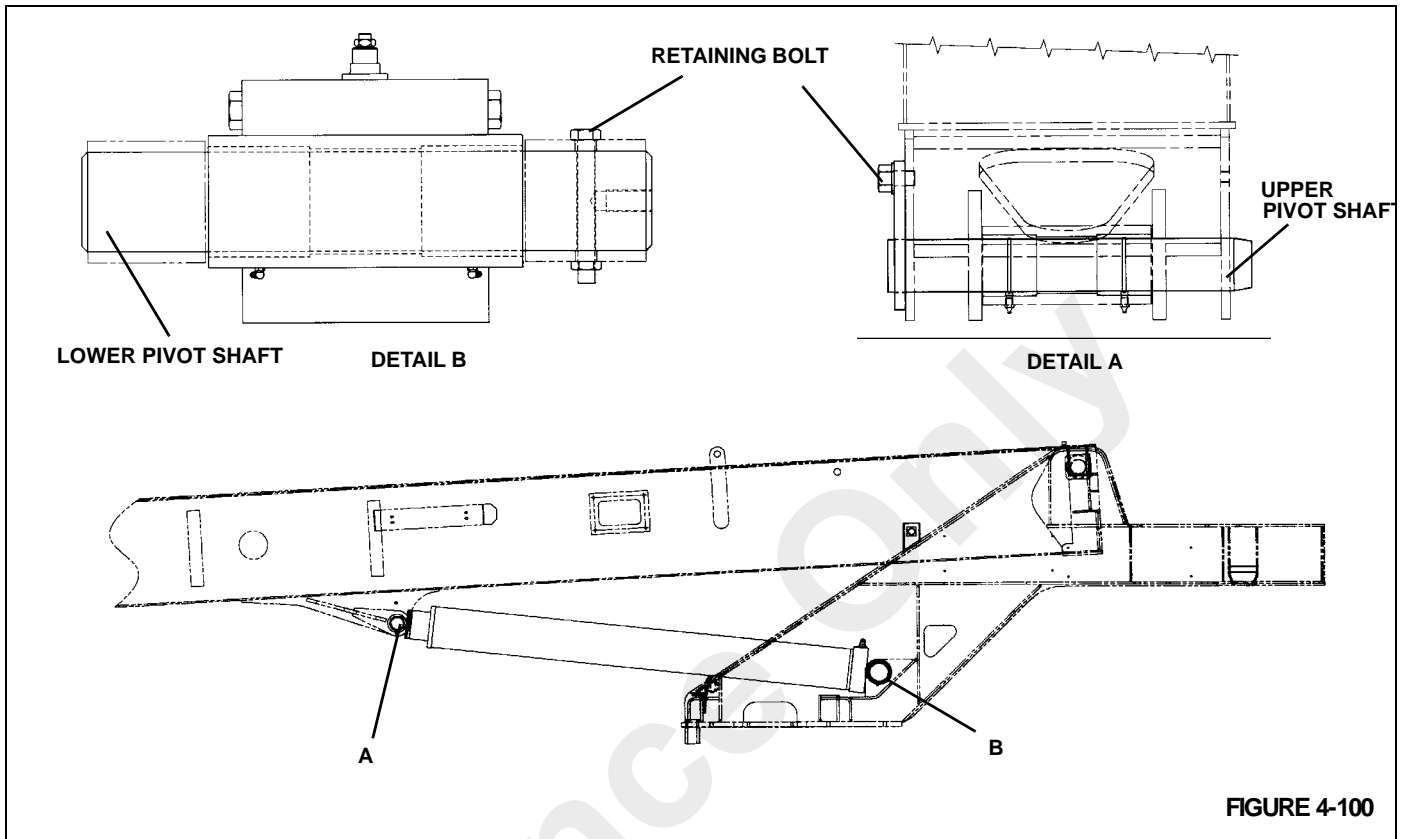

4

Reference

Reference Only

THIS PAGE BLANK

SECTION 5 HOIST AND COUNTERWEIGHT

SECTION CONTENTS

Description	5-1	Brake Test Procedure for HP15C-17G, HO30A-19G, HP35-26G HOISTS	5-6
Theory of Operation	5-1	Brake Test Procedure (To be performed with no load on the hoist)	5-6
Maintenance	5-2	Hoist to Boom Alignment	5-7
Warm-up Procedure	5-2	Preparation	5-7
Removal	5-2	Tools Required	5-7
Installation	5-3	Procedure	5-7
Functional Check	5-3	Piston Motor and Control Valve	5-8
Servicing	5-3	Description	5-8
Hoist Maintenance and Inspection	5-4	Maintenance	5-8
Usage and Inspection	5-4	Idler Drum and Cable Follower	5-9
Pre-Use or Daily Inspection	5-5	Description	5-9
Quarterly Inspection (every three months)	5-5	Maintenance	5-9
Semi-Annual Inspections (every six months)	5-5	Hoist Drum Rotation Indicator System	5-11
Annual Inspection	5-5	Description	5-11
PREVENTIVE MAINTENANCE AND OIL SAMPLING	5-5	Maintenance	5-11
Oil Change	5-5	Counterweight Removal	5-13
Gear Oil Sampling and Analysis	5-5		

DESCRIPTION

One hoist is available; the HP15C-17G (Figure 5-1). The hoist incorporates one dual displacement piston motor which drives a reduction unit within the hoist. The hoist utilizes planetary reduction with a multi-disc automatic brake that is spring applied and hydraulically released. An overrunning clutch allows the hoist to be raised without releasing the brake while at the same time holding the load until there is sufficient pressure to release the brake when hoisting down. The hoist motor controls both speed and torque of the hoist.

There are two modes in which the hoist operates. One mode is high speed. The pilot solenoid valve shifts the selector spool on the motor to provide minimum motor displacement. This gives high line speed and low torque.

The second mode is low speed. The pilot solenoid valve shifts the selector spool on the motor to provide maximum motor displacement. This gives low line speeds and high torque.

THEORY OF OPERATION

The hoist assembly is controlled by hydraulic remote controllers located in the cab. When the control lever in the cab is moved from neutral, it causes the hoist section of the directional control valve to shift the valve spool to route hydraulic flow to the hoist motor control valve. The hoist motor control valve is used to stop or slow the hoist when the load is trying to drive the hoist down too quickly. The motor control valve is piloted open by the hoist down pressure. If the load lowers faster than the flow of oil in the hoist down line, the pilot pressure decreases and the motor control valve partially closes to restrict the oil leaving the motor until a balance occurs. This results in the load lowering at a uniform speed based on the position of the hoist control lever.

During stopping, when the hoist down flow ceases, the pilot pressure holding the motor control valve open decays to zero and the motor control valve spool closes, thus blocking all flow of oil out of the hoist motor. This same pressure decay allows the spring applied pressure released hoist brake to apply when the load is fully stopped. This brake acts as a “parking brake” and holds the load in the stopped position.

MAINTENANCE

Warm-up Procedure

A warm-up procedure is recommended at each start-up and is essential at ambient temperatures below 4°C (+40°F).

The prime mover should be run at its lowest recommended RPM with the hydraulic hoist control valve in neutral allowing sufficient time to warm up the system. The hoist should then be operated at low speeds, forward and reverse, several times to prime all lines with warm hydraulic oil, and to circulate gear lubricant through the planetary gear sets.



DANGER

Failure to properly warm up the hoist, particularly under low ambient temperature conditions, may result in temporary brake slippage due to high back pressures attempting to release the brake, which could result in property damage, severe personal injury or death.

Removal

1. If the CE option is provided, remove the hoist covers.
2. Remove all cable from the hoist drum.
3. Tag and disconnect the hydraulic lines to the hoist. Cap or plug all lines and openings.
4. Tag and disconnect the electrical wires to the hoist rotation indicator sensor.
5. Tag and disconnect the electrical wires to the hoist hi-speed solenoid valve.
6. Remove the hoist mounting nuts, capscrews, washers, and shims (if shims are used, mark their location).

NOTE: The HP15C-17G hoist assembly, less the cable, weighs approximately 340 kg (741 lb).

7. Using an adequate lifting device, remove the hoist from the crane.

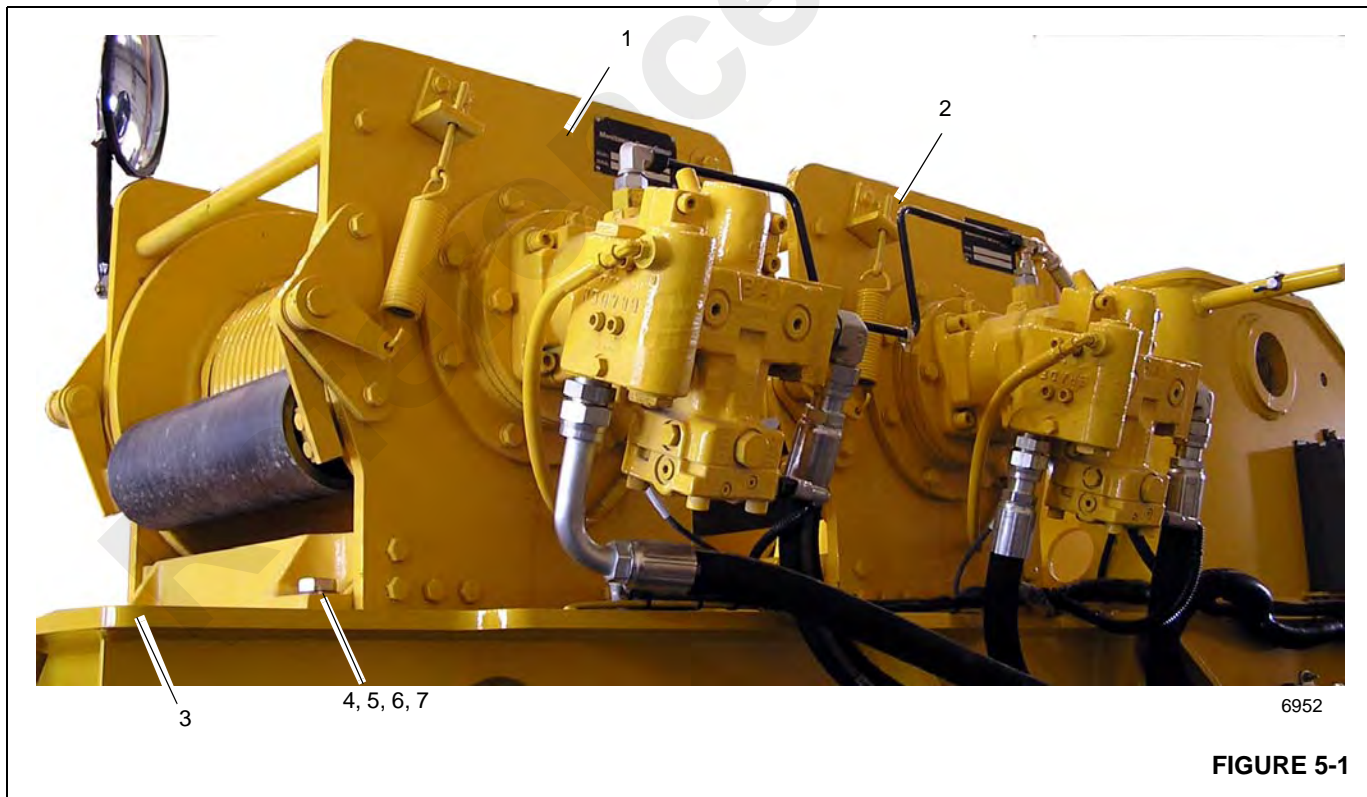

Item	Description
1	Auxiliary Hoist
2	Main Hoist
3	Turntable
4	Capscrew
5	Washer
6	Hex Nut
7	Shims

Installation

1. Ensure the mounting plate and hoist pads are clean and free from debris and the hoist has not been damaged during handling.
2. With the hoist supported by a suitable lifting device, position the hoist on the mount.
3. Check the hoist to boom alignment according to the HOIST TO BOOM ALIGNMENT procedure in this section.
4. Place a level between the boom pivot shaft bushings.
5. Place a level across the top of the hoist drum and determine if the hoist is sitting in the same plane in

Functional Check

1. Attach a test weight to the hook and raise and lower the load several times.
2. Check the hoist for smooth operation of the hoist motor and brake system.

relation to the level positioned between the boom pivot shaft bushings.

6. With the hoist level, check to determine if all the hoist mounting pads are in contact with the mounting plate by rocking the hoist.
7. Keeping the hoist level, use a feeler gauge to determine the amount of gap existing between the pads and the mounting plate.
8. Add shims to satisfy any existing gaps. Altering the shim thickness to fit a tapering gap is acceptable. Install the capscrews, washers and nuts and torque see Fasteners and Torque Values (pg 1-11).
9. Remove the lifting device from the hoist.
10. Connect the hydraulic lines to the hoist ensuring the proper lines are connected to the correct ports as marked during removal.
11. Connect the electrical wires to the hoist hi speed solenoid valve as marked during removal.
12. Connect the electrical wires to the hoist rotation indicator sensor as tagged during removal.
13. Install the cable, following the procedures outlined under INSTALLING CABLE ON THE HOIST, in the Operator Manual.

3. Ensure the hydraulic connections are secure and free from leaks.

Servicing

Remove the large plug from the center of the drum support. Fill with AGMA EO-4 (Grove Spec 6829100213) gear lubricant until level with the plug opening. Check every 1000 hours or 12 months.

HOIST MAINTENANCE AND INSPECTION

It is extremely important that maintenance staff involved with the crane inspections be made aware of the possibility that deterioration of internal critical components within the hoist can occur. Hoists incorporate planetary gears, multi-disc brake assemblies and sprag clutches which do not have an infinite service life span. Although these components have been designed to achieve long service life, reliability can be substantially reduced by a variety of influencing factors such as:

- High cycle operation
- Operating in high ambient temperatures
- High external contamination, such as dusty or sandy conditions
- Type of lubricant used
- Level of maintenance

The following routine servicing points must be carried out in accordance with manufacture’s instructions:

Usage and Inspection

Inspection procedures for hoists are divided into five general

categories based upon their usage or duty cycle, which in turn determines appropriate intervals for inspections. The usage categories must be assigned by the crane user on a consistent crane-by-crane basis. The five crane/hoist usage categories are as follows:

- **Idled** - The crane/hoist has not been used for three months.
- **Infrequent Usage** - The crane/hoist is used less than ten hours per month based on a three month average
- **Moderate Usage** - Crane/hoist used 10 - 50 hours per month based on a three month average.
- **Heavy Usage** - Crane/hoist used 50 - 200 hours per month.
- **Severe Duty** - Crane/hoist is operated more than 200 hours per month OR where 50% of the lifts exceed 75% of the rated capacity for the hoist.

NOTE: For idled units with unknown maintenance and repair history, it is highly recommended that the hoist undergo a tear down inspection prior to being placed into service.

The following chart lists the inspections that are required for each type of usage category:

INSPECTION USAGE CATEGORY	PRE-USE DAILY INSPECTION	QUARTERLY INSPECTION	SEMI-ANNUAL INSPECTION	ANNUAL INSPECTION
IDLED Not used for 3 months or longer	REQUIRED BEFORE PLACED IN SERVICE	REQUIRED BEFORE PLACED IN SERVICE	REQUIRED BEFORE PLACED IN SERVICE	---
INFREQUENT USAGE less than ten hours per month	REQUIRED	REQUIRED	REQUIRED	REQUIRED
MODERATE USAGE 10-50 hours per month	REQUIRED	REQUIRED	REQUIRED	REQUIRED
HEAVY USAGE 50-200 hours per month	REQUIRED	REQUIRED MONTHLY	REQUIRED QUARTERLY (3 months)	REQUIRED SEMI-ANNUALLY (6 months)
SEVERE USAGE 200+ hours per month or 50% of lifts exceed 75% rated capacity	REQUIRED	REQUIRED	REQUIRED QUARTERLY (3 months)	REQUIRED SEMI-ANNUALLY (6 months)

Pre-Use or Daily Inspection

Must include but is not limited to the following inspections that will be performed prior to placing the crane into service and then as necessary during extended operation. This inspection must be performed by a qualified crane operator or qualified crane technician.

1. Check for external oil leaks and repair as necessary. This is extremely important due to the accelerated wear that will result from insufficient lubricating oil in the hoist. Hoists with a sight glass; check oil level daily. Hoists without a sight glass; check oil level monthly if no external oil leaks are detected. Lubricant level must be maintained between the minimum and maximum levels; midway up sight glass or at bottom of level plug port as equipped. Use **ONLY** the recommended type of lubricant. Refer to the machine's lubrication chart.
2. Check hydraulic fittings and hoses for chaffing, deterioration or corrosion and repair as necessary.
3. 3. Visually inspect for corroded, loose or missing bolts, pins or other fasteners and replace or tighten as necessary.
4. 4. Visually inspect rotation indicator transmitters, anti-two-blocking switches and other safety equipment and repair as necessary.

Quarterly Inspection (every three months)

Must include but is not limited to the following inspections that must be performed by a qualified crane operator or qualified crane technician.

1. Perform the pre-use inspection.
2. Inspect for corrosion of fasteners, hoist base, drum, etc. and repair/replace as required to maintain the structural integrity of the hoist.

Semi-Annual Inspections (every six months)

1. Perform the pre-use and quarterly inspections.
2. Take a sample of the lubricant from the hoist gear cavity as described on this page and analyze it for wear metals content, correct viscosity, lubricant deterioration, moisture and other contaminants. If the oil sample contains a high amount of metallic particles, the hoist must be taken out of service to undergo a tear down inspection.

NOTE: Oil analysis alone cannot detect nor warn against a fatigue failure.

Annual Inspection

This inspection must be carried out by a qualified crane technician. The annual inspection **MUST** include, but not be limited, to the following:

1. Perform the pre-use/daily, quarterly and semi-annual inspections.
2. Change the lubricating oil in the hoist gear cavity after an oil sample has been taken as described on this page. Refill the hoist to the proper level with recommended lubricant. Refer to the machine's lubrication chart.



WARNING

Possible equipment damage and/or personal injury!

Failure to use the proper type and viscosity of planetary gear oil may contribute to intermittent brake clutch slippage which could result in property damage, severe personal injury or death. Some gear lubricants contain large amounts of EP (extreme pressure) and anti-friction additives which may contribute to brake clutch slippage or damage to brake friction discs or seals. Oil viscosity with regard to ambient temperature is also critical to reliable brake clutch operation. Our tests indicate that excessively heavy or thick gear oil may contribute to intermittent brake clutch slippage. Make certain that the gear oil viscosity used in your hoist is correct for your prevailing ambient temperature.

PREVENTIVE MAINTENANCE AND OIL SAMPLING



WARNING

Risk of personal injury!

Hot oil may cause personal injury and/or burns to unprotected skin. Make certain the oil has cooled to a safe temperature (typically less than 43°C or 110°F) before taking an oil sample, changing oil or servicing the hoist.

Oil Change

The hoist gear oil must be changed after the first 100 operating hours then on an annual basis, at a minimum thereafter. In severe duty applications, the gear oil should be changed every six months. Use the recommended lubricants. Refer to the machine's lubrication chart.

Gear Oil Sampling and Analysis

Proper gear oil sampling and analysis is a vital part of a comprehensive preventive maintenance program. Information obtained from the oil analysis allows the maintenance technician to substitute preventive maintenance for more costly unscheduled down time or a far more dangerous failure. Early detection of accelerated

component wear allows the scheduling of corrective maintenance.

Prepare the hoist by cleaning the drain plug area and drain extension tube in order to obtain an uncontaminated sample. Operate the hoist in both directions for one or two minutes to thoroughly mix the gear oil then take the sample from the midstream flow of the oil to obtain an accurate

representation of the oil condition. After taking the oil sample continue with the oil change or refill the hoist gear cavity to the proper level with recommended lubricant. Iron contaminant levels will be on the high side of "normal" during initial break-in.

General guidelines for iron contaminant level

PPM	Condition of Oil
100-500	Normal - Acceptable level; little significant contamination
500-800	Caution - Abnormal sample. Change oil and retake sample after 50 hours of operation. If second sample is above 500 ppm, remove hoist from service and perform tear-down inspection to determine source of contamination.
Over 800	Unacceptable - Remove hoist from service and perform tear-down inspection to determine the source of contamination.

Equally important as the level of contamination is the change in level of contamination. An effective oil analysis program should provide the technician with a view of the progression of wear or a trend. If a sample shows a sudden rise in contaminant level action should be taken to determine what has changed.

NOTE: Oil analysis alone cannot detect nor warn against a fatigue failure.

BRAKE TEST PROCEDURE FOR HP15C-17G, HO30A-19G, HP35-26G HOISTS

All of the above model planetary hoists have a spring applied, hydraulically released, multiple disc brake inside the hoist housing. This brake holds a suspended load when the directional control valve is in neutral, or when hydraulic power is lost. An over-running brake clutch assembly permits the power train and drum to rotate in the direction to lift a load, while the brake remains fully applied. A load cannot be lowered, however, without applying hydraulic pressure to the release port and releasing the brake.

Brake Test Procedure (To be performed with no load on the hoist)

- Remove and cap or plug the brake release line from fitting in the hoist brake release port.
- With the hydraulic power unit running, move the directional control valve handle slowly to the full open, lowering position.
- Increase the engine speed, if necessary, to bring system pressure up to the relief valve setting. The hoist drum should remain stationary
- If the hoist drum rotates, the hoist should be disassembled and the brake components should be examined for wear. In addition, the brake springs should be measured for the correct free length in those hoist using helical compression springs.
- Replace any parts showing excessive wear and any spring whose length is shorter than the minimum shown in the applicable hoist Service Manual.
- Reassemble the brake and hoist, then repeat the above steps.
- When testing is complete, reattach the brake release line to the brake release port.

Contact CraneCARE with any questions

HOIST TO BOOM ALIGNMENT

Preparation

Boom alignment must be completed before attempting hoist alignment. If the hoist is not properly aligned, the cable can be damaged or fine control could be affected.

The crane must be set on outriggers fully extended and the crane must be leveled. The boom must be over the front.

Tools Required

- Two foot square
- Mason cord
- Chalk
- Protractor

Procedure

The hoist mounting location will determine the alignment procedure used. Shift one side of the hoist back or forward to align the hoist with the boom sheave for cranes that have the hoist mounted either directly to the boom or on a mount attached to the boom. It may be necessary to shim under one side of the hoist to make it level.

The hoist must be checked in two directions, one at 0 degree and the other is above 45 degree boom angle on any crane that the hoist is not mounted directly to the boom, stationary mounted.

Check the hoist at 0 degree to see if the hoist is aligned to the boom nose sheave. The main hoist is aligned to the right hand sheave and the auxiliary hoist is aligned to the center sheave (Figure 5-2)

NOTE: The hoist cable will have gaps in it during spooling if the alignment is not correct.

NOTE: The hoist is not level if the cable is piling up on one side of the drum.

1. The boom must be extended one half of full extension on all hoist alignments. This length is used because when the main hoist cable is positioned on the top right hand boom nose sheave, the cable must leave the center of the drum at a 90 degree angle. The boom has the ability to extend, retract, and change the angle of departure from the drum. Extend the boom half way to provide a

center point of adjustment to check the fleet angle of the cable.

2. All the cable must be removed from the hoist drum to check the fleet angle. Using mason cord or cat gut fishing line you will be able to pull the line tight to make an accurate measurement of the fleet angle. Find the centerline of the hoist drum by using a square and drawing a line horizontal on the drum. Put a line vertical to the horizontal line in the absolute center of the drum by using a tape measure. With the boom at 0 degree, tie the line tight to the boom nose and have it in the center of the right hand boom nose sheave.

NOTE: If this special equipment is not available, sufficient accuracy in locating a centerline may be obtained by using a steel square against the machine's inner surfaces of both flanges. It is advisable to avoid using any cast surfaces in this procedure unless a check from both flanges indicates that the resultant line is straight.

3. Tie the line around the hoist drum so that the line is very tight and the line is crossing the absolute center of the drum at the centerline mark you put on the drum.
4. Using a protractor, lay it on the vertical line on the hoist drum so the string line is in the center of the protractor. The string line will be at the 90 degree mark on the protractor if the hoist is straight with the boom nose sheave. If it is not at the 90 degree mark, the hoist mounting bolts will have to be loosened and the hoist moved so it is.

NOTE: This test is for cable leaving gaps while spooling.

CAUTION

Do not alter holes or stop blocks on the crane mounting plate, as very small adjustments result in large angular changes. Extreme care should be taken to avoid over-correction.

5. Elevate the boom above 45 degree boom angle to check if the hoist is level. Reposition the hoist drum and tighten the cord so you can have the cord in the center of the protractor at the 90 degree mark. If the cord is not at the 90 degree mark, the hoist will have to be shimmed until the cord is at the 90 degree mark.

NOTE: This test is for cable piling up on one side of the hoist drum.

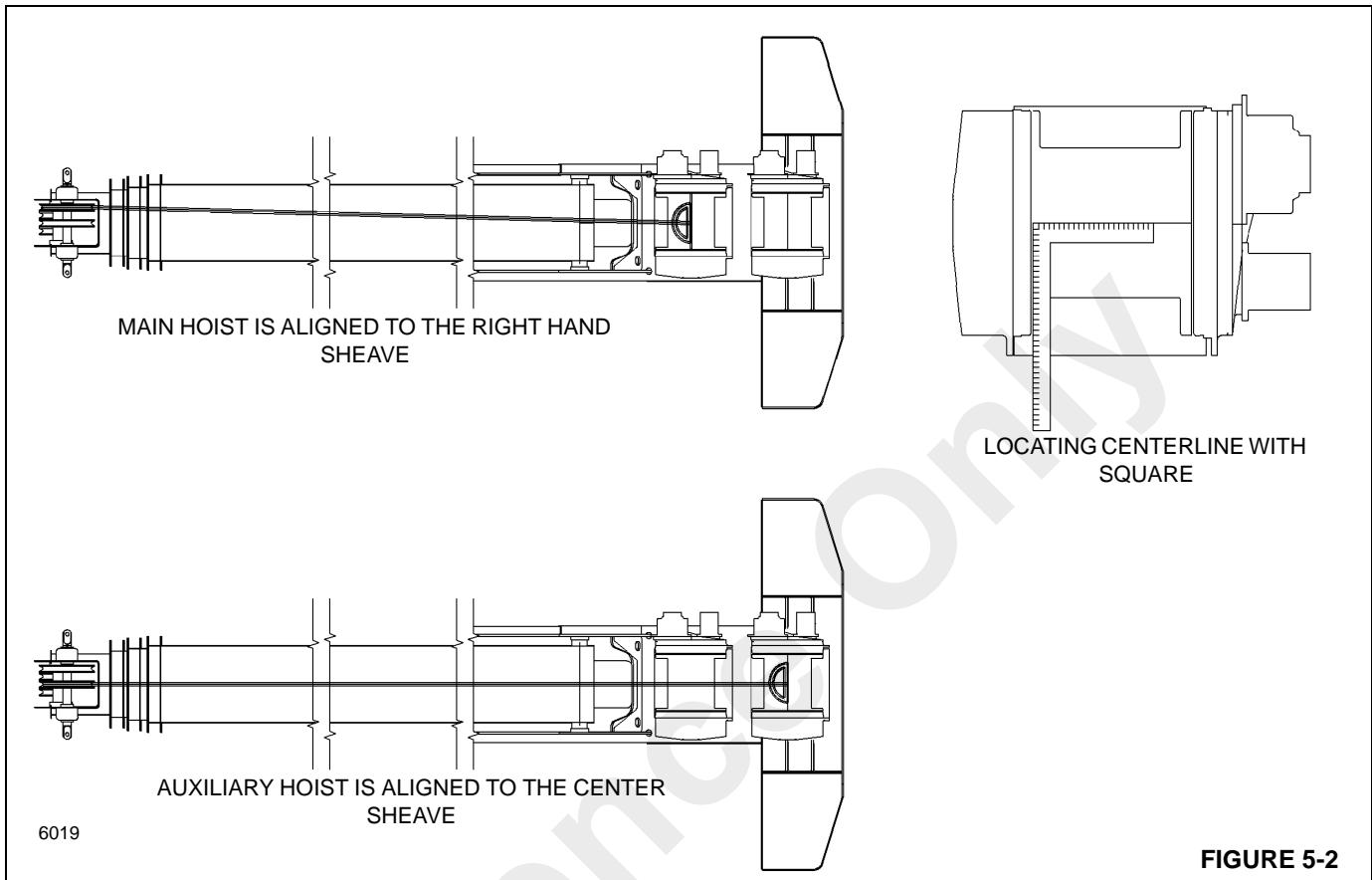

FIGURE 5-2

PISTON MOTOR AND CONTROL VALVE

Description

The piston motor is a bent axis, bidirectional, variable displacement heavy-duty motor. The motor is bolted to the hoist and is geared directly to the hoist planetary.

The motor control valve is bolted to the motor.

Maintenance

Removal

1. Thoroughly clean the external surfaces of the drum and motor with steam or clean solvent and blow dry.
2. Tag and disconnect the hydraulic lines connected to the hoist motor and the motor control valve.
3. Remove the capscrews and lockwashers that secures the motor and motor control valve to the hoist.

NOTE: The HP15C-17G hoist motor weighs approximately 28 kg (62 lb).

4. Place the motor and motor control valve in a clean, dry suitable work area.

Installation

NOTE: Care must be taken to assure the primary thrust plate remains properly located in its counterbore when the motor is re-installed. If the winch is operated with the primary thrust plate wedged between the primary gears and the planet carrier, or with a thrust washer out of position severe damage to internal winch components could result.

1. Install a new O-ring on the motor pilot then lubricate with petroleum jelly or gear oil. Engage the motor shaft with the brake clutch inner race and lower into place.
2. Apply Loctite No. 243 to the mounting bolts, and install the bolts and lockwashers. Torque the bolts to 102 Nm (75 lb-ft).
3. Connect the hydraulic lines as tagged during removal.
4. Fill the drum with oil. Refer to Section 9 - LUBRICATION in this manual.

IDLER DRUM AND CABLE FOLLOWER

Description

The main and auxiliary hoists are equipped with an idler drum on the forward side of the hoist. The main hoist idler drum is used to keep the hoist cable from coming in contact with the boom. When the crane is also equipped with an auxiliary hoist, the idler drum on the auxiliary hoist is used to keep the hoist cable from coming in contact with the main hoist. The cable follower is mounted on the rear side of its respective hoist. The cable follower applies a downward spring pressure against the cable onto the hoist drum, to ensure that the cable will be uniformly wound onto the hoist drum, and also prevent cable from jumping under abnormal line conditions.

Maintenance

Idler Drum

Removal and Disassembly

1. Remove the bolt, washer, and lockwasher from the right side of the idler roller (Figure 5-3).
2. Support the idler roller and withdraw the shaft from the left side. Take care not to lose the dowel pin on the end.
3. Remove the roller from between the side plates.

Cleaning and Inspection

1. Clean all rust and dirt from the shaft.
2. Inspect the shaft and roller for cracks, scoring, or grooving. Replace if necessary.

Assembly and Installation

1. Position the roller between the side plates
2. Install the shaft through the left side plate and the roller. Ensure the flat on the shaft end aligns with the stop welded on the side plate, align the dowel pin.
3. Secure the shaft to the right side plate with a bolt, washer and lockwasher. Apply Loctite 243 to the bolt threads.

Cable Follower

Removal and Disassembly

1. Loosen the adjusting nuts and remove the tension spring and adjusting rod from both sides of the hoist (see Figure 5-3).
2. Remove the tack welds from the bolt heads securing the arm to the cable follower roller.
3. Support the cable follower roller and remove the bolts and washers securing the arms to the angles on each end of the roller. Remove the cable follower roller.

4. Disassemble the cable follower roller as follows.
 - a. Remove the two bolts and washers securing the angle to the right side of the shaft.
 - b. Remove the shims and roller from the shaft.
 - c. If necessary, remove the bearing and bearing housing from both ends of the roller.
5. Remove the bolt and locknut securing the arm to the spring attaching lever on each side of the hoist. Remove arms and levers from the side plates.

NOTE: Be sure to mark each arm and lever as to what side (left or right) they were removed from. This will be helpful during installation.

Cleaning and Inspection

1. Clean all grease from the shaft, bearing, and roller.
2. Check the shaft, roller, and bearings for cracks, scoring, or grooving. Replace if necessary.
3. Check the spring tension. If the springs will not provide sufficient tension when adjusted, replace them.

Assembly and Installation

1. Install the left arm through the bushing on the left side plate. Install left spring attaching lever on the arm and secure with a bolt and locknut. Apply Loctite 243 to the bolt threads.
2. Repeat step 2 on the right side.
3. Assemble the cable follower roller as follows.
 - a. Apply high strength retaining compound Loctite 680 to the bearing housings and the bearings. Install them in both ends of the roller.
 - b. Install the shaft into the roller with a least one shim on each end.
 - c. Position the angle on the right side of the shaft and secure with two bolts and washers. Apply Loctite 243 to the bolt threads.
4. Position the cable follower roller on the arms and secure with four bolts and washers. Center the roller between the hoist drum flanges and tighten the bolts. Tack weld the bolt heads.
5. Attach one end of the tension springs to the levers on each side. Install the adjusting rod through the lug on each side plate and connect to the other end of the spring. Install the adjusting nuts on each rod and tighten enough to take the slack out of the springs.
6. Using a grease gun, apply grease to the fittings on each side plate bushing.
7. Adjust the roller as follows.

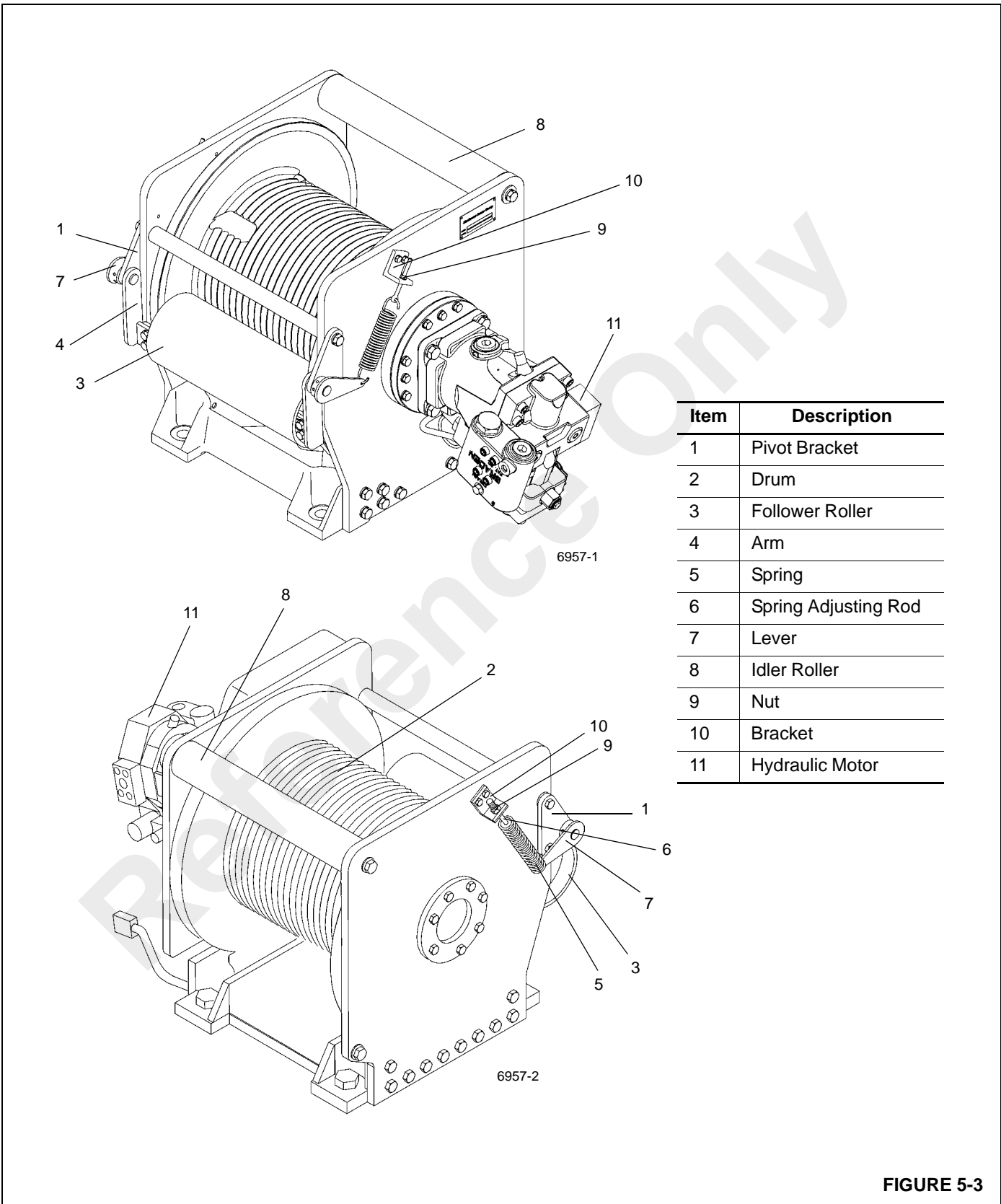

FIGURE 5-3

- a. With one layer of cable on the hoist drum, adjust the bolts on the front of each side plate (that push against each arm) so the roller applies pressure on the layer of cable, and does not interfere with filler/riser protrusions on the hoist drum flanges. Tighten jam nuts to secure setting.
- b. With a full drum of cable, the adjusting spring length from eye to eye should not exceed 25.7 cm (10.12 in). Adjust rods as necessary and tighten jam nuts to secure this setting.

Complete Assembly

Removal

1. Remove all tension from the springs on each side by loosening the nuts and jam nuts.
2. Support the weight of the assembly and remove the two bolts and washers securing each side plate to the hoist. Remove the idler drum and cable follower assembly from the hoist.
3. If necessary to completely disassemble or remove any part of the assembly, refer to the applicable paragraphs in this Sub-section.

Installation

1. Position the idler drum and cable roller assembly on the hoist and secure each side plate to the hoist with two bolts and washers.
2. Adjust the tension on the cable follower. Refer to instructions in paragraph titled CABLE FOLLOWER - Assembly and Installation in this Sub-Section.

HOIST DRUM ROTATION INDICATOR SYSTEM

Description

The hoist drum rotation indicator system (Figure 5-4) is an electrically operated system that provides the operator with a touch indication of drum rotation so the operator will know if and at what speed the hoist drum is rotating, even under the most distracting conditions. The RCL Display will also

illuminate a hoist up or hoist down indicator light to show the direction of hoist motion.

The rotation indicator system consists of the rotation indicator sensor and thumb thumper solenoid. The rotation sensor is located on the hoist. The pulsing thumb thumper solenoid is located in the applicable hoist control lever handle. Actuation of the thumb thumper and illumination of the direction lights is controlled by the Can-Bus system from input supplied by the rotation indicator sensor.

Maintenance

General



DANGER

Disconnect the batteries before performing any maintenance on this system. Serious burns may result from accidental shorting or grounding of live circuits.

Proper circuit operation can be checked for each individual electrical component. If a malfunction occurs within the system, repairs should be limited to finding and replacing the faulty component(s). To determine which component is at fault, refer to the troubleshooting section of your Can-Bus CD.

Rotation Sensor

The rotation sensor is screwed into the hydraulic motor housing and senses the rotation of the motor drive shaft. When installing the sensor, ensure it contacts the top land of a gear tooth and not between teeth (See figure titled Hoist Rotation Indicator System). Screw the sensor in until contact is made, then back out 1/4 turn minimum to 3/4 turn maximum, stopping when the white and green wires are within the 7:00 to 11:00 range (when looking into the sensor port with the drum on operator's left side).

Thumb Thumper Solenoid

The thumb thumper solenoid provides feedback proportional to the hoist line speed by pulsing the rubber button on top of the hoist controller. The thumb thumper will cease operation at high line speeds to prevent damage to the solenoid.

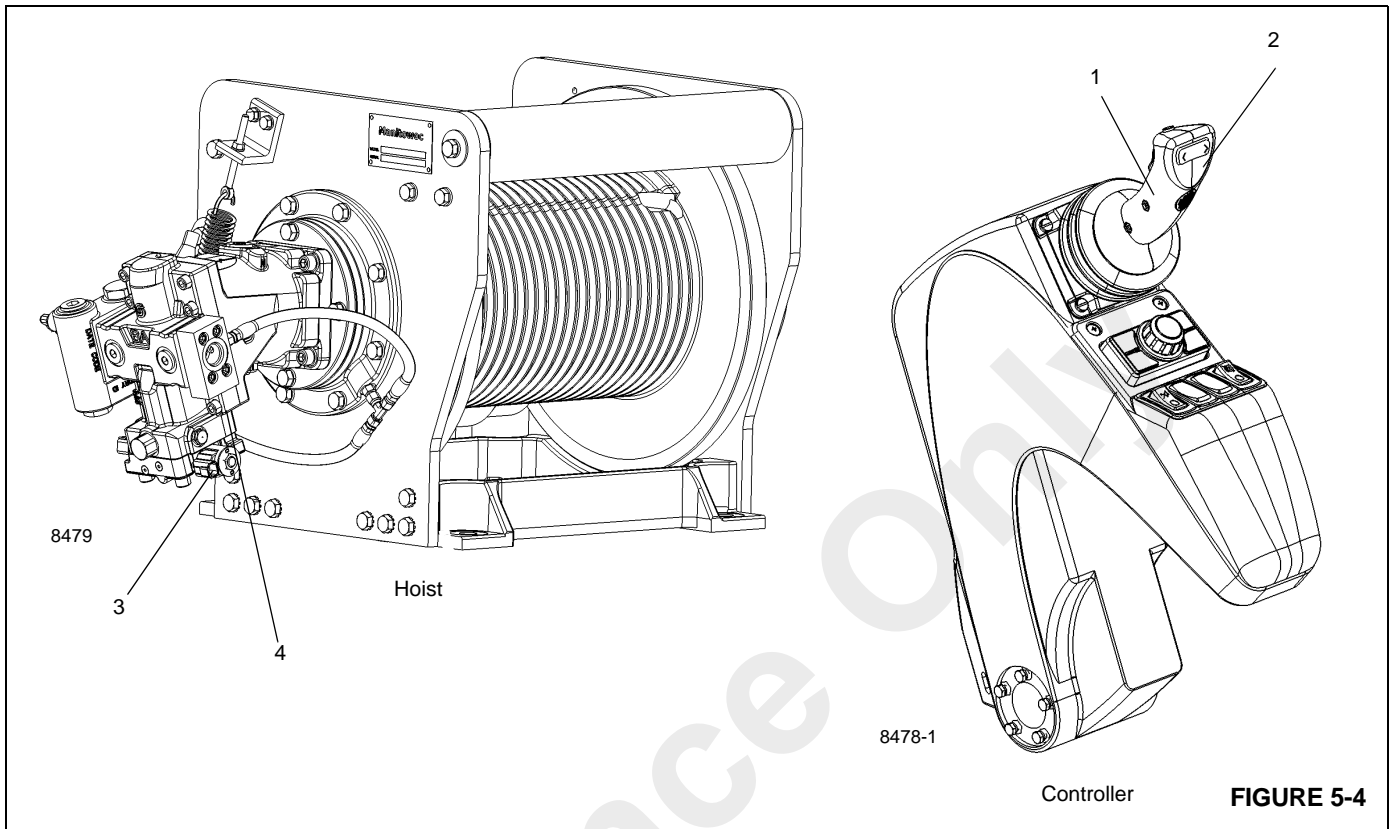

Item	Description
1	Thumb Thumper
2	Controller
3	Rotation Sensor Connection
4	Two Speed Solenoid Connection

COUNTERWEIGHT REMOVAL

Fixed Counterweight Description

The counterweight is pinned to the rear of the turntable and weighs 4300 kg (9480 lb). For cranes without an auxiliary hoist, an additional 350.6 kg (773 lb) counterweight is bolted to the hoist mounting area in lieu of the auxiliary hoist.

Fixed Counterweight Removal



DANGER

Death or serious injury could result from being crushed by a falling counterweight.

Ensure the retainer pin is properly installed to secure the counterweight mounting pin.

NOTE: Use of a forklift to remove/install the fixed counterweight is not recommended.

Refer to (Figure 5-5) for counterweight removal.

1. Fully extend and set the outriggers.

NOTE: Turntable lock pin can only be engaged with boom over front.

2. Rotate the superstructure so the counterweight is over the front of the carrier to gain additional clearance.

NOTE: The counterweight weighs approximately 4300 kg (9480 lb).

3. Lower and fully retract the boom
4. Shut down crane.
5. Attach an adequate lifting device to the counterweight.
6. Ensure the four counterweight leveling capscrews are set for maximum clearance with the turntable.
7. Slowly raise counterweight until pin assembly can be removed by pushing and turning the pin.
8. Remove pin assembly from opposite side.

9. Lower counterweight until attaching lugs are clear of the turntable.
10. Back counterweight away from turntable until it is clear of crane.
11. Replace pin assembly in turntable counterweight mounting lugs.
12. Move counterweight far enough from crane to allow the turntable/superstructure to clear during repositioning.
13. Rotate superstructure to the normal travel position.

Fixed Counterweight Installation

1. Fully extend and set the outriggers.
2. Rotate the superstructure so the counterweight will be over the front of the carrier to gain additional clearance.
3. Shut down crane.

CAUTION

When lifting/handling the counterweight, keep the chains/straps vertical to minimize side pull on the lifting lugs.

NOTE: The counterweight weighs approximately 4300 kg (9480 lb).

NOTE: Use of a forklift to remove/install the fixed counterweight is not recommended.

4. Attach an adequate lifting device to the counterweight and lift the counterweight into place on the superstructure, aligning the mounting holes on the counterweight to the holes in the superstructure.
5. Install the counterweight mounting pins and secure them in place with hitch pin retainers.
6. Remove the lifting device from the counterweight.
7. Using the four counterweight leveling bolts, level the counterweight and eliminate any relative movement between the counterweight and turntable. Maximum width of counterweight shall not exceed 6.0 mm (0.25 in) out of level with the turntable bearing when measured from either counterweight outer edge.

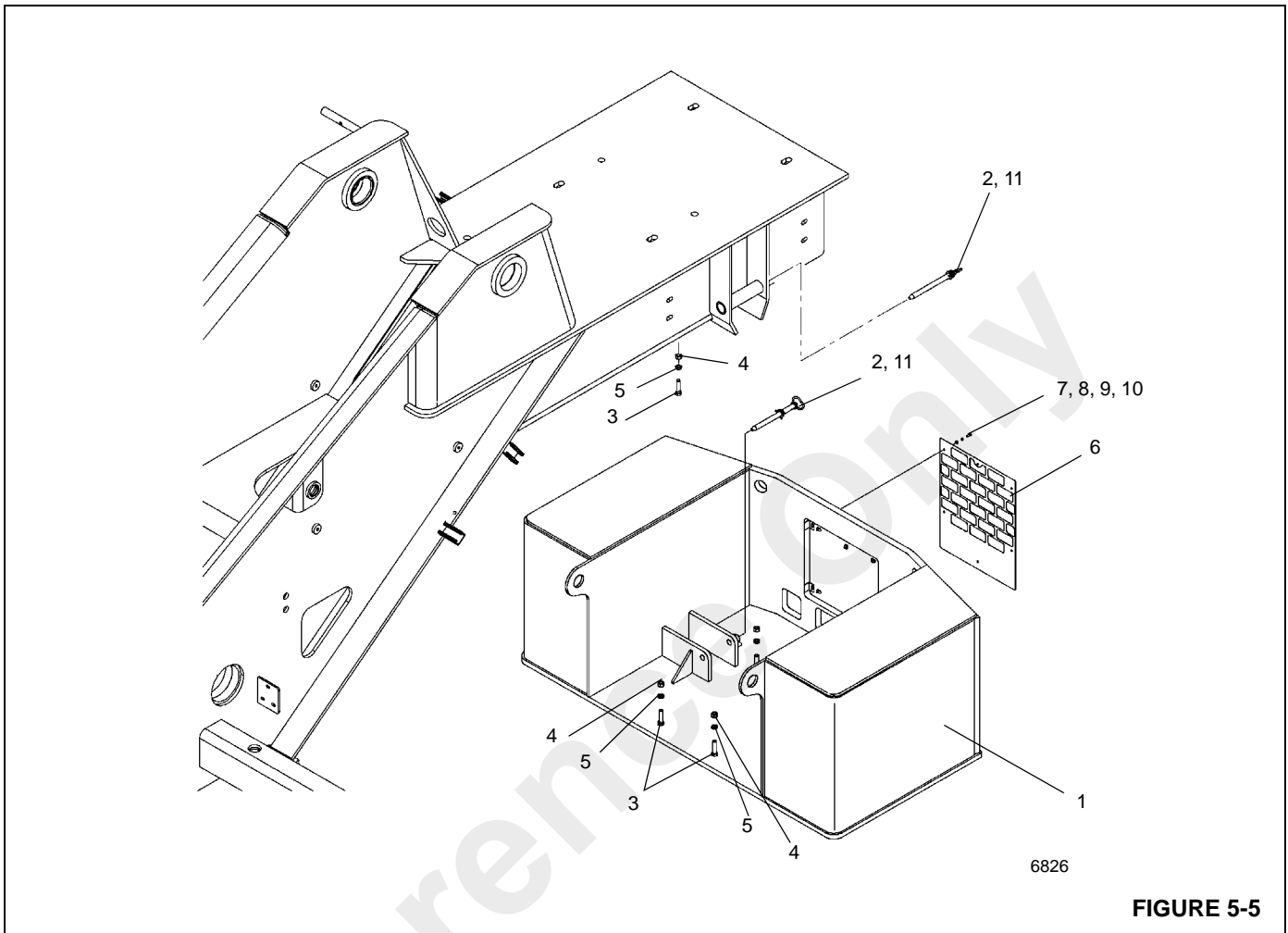

FIGURE 5-5

Item	Description
1	Counterweight
2	Pin Assembly
3	Capscrew
4	Hex Nut
5	Jam Nut
6	Grill
7	Retaining Nut
8	Flat Washer
9	Lock Washer
10	Capscrew
11	Lock Pin

SECTION 6 SWING SYSTEM

SECTION CONTENTS

<p>Introduction 6-1</p> <p> Description 6-1</p> <p> Theory of Operation 6-1</p> <p> Maintenance 6-3</p> <p> Troubleshooting 6-3</p> <p>Swing Motor 6-6</p> <p> Description 6-6</p> <p> Maintenance 6-6</p> <p>Swing Gearbox And Brake 6-7</p>	<p> Description 6-7</p> <p> Maintenance 6-7</p> <p>Swing Bearing 6-9</p> <p> Description 6-9</p> <p> Maintenance 6-9</p> <p>Swivels 6-14</p> <p> Description 6-14</p> <p> Hydraulic Swivel 6-16</p> <p> Electrical Swivel 6-18</p>
---	---

INTRODUCTION

Description

The purpose of the swing system is to allow the crane superstructure to rotate atop the carrier frame. The superstructure swing system provides full 360 degree rotation in both directions and is equipped with free swing capabilities. The term free swing means that, with the SWING BRAKE switch in the OFF position, the superstructure will swing freely after the SWING control lever is released until it coasts to a stop or the glide swing brake pedal is depressed.

Swing is activated using the Swing Enable Switch and the control lever in the cab. When the swing lever is actuated, hydraulic pressure is routed to the swing motor to drive the gearbox in the appropriate direction. As the gearbox rotates, the pinion gear meshes with the teeth on the swing bearing and rotates the superstructure. Swing speed can be controlled by the control lever and a HIGH/LOW swing speed switch on the joystick. The maximum rotation speed is 2.0 rpm with no load. Positioning the lever to the left or right actuates a control valve through electric signal to provide 360 degree continuous rotation in the desired direction. Braking is accomplished by moving the control lever to the center and applying Swing Brake Pedal or engaging the Swing Brake Switch.

The swing system consists of a electric remote controller, swing speed switch, a directional control valve, the swing

drive, the swing brake assembly, the brake pedal and power brake valve, and a swing brake release solenoid valve.

The crane is equipped with a pin type turntable lock as standard and an optional 360 degree positive swing lock. The 360 degree positive swing lock meshes with the swing gear teeth at any point of rotation. The pin type turntable lock will only lock the turntable in a straight ahead position over the front of machine. Both swing locks are operated from the cab.

Theory of Operation

Swing Drive

The hydraulic power for the swing drive (Figure 6-1) is supplied by the engine driven hydraulic pump. Oil flows from the pump to the hydraulic Port 5 swivel. Flow from the swivel is routed to the service brake dual accumulator charge valve. Bypass flow from the dual accumulator charge valve is routed to the front steering flow divider valve in the swing directional control valve. Bypass flow from the flow divider valve is used to supply the swing directional control valve.

When the electric remote control is positioned to select right or left swing, the flow through the control valve is directed to the swing motor. If the SWING BRAKE selector switch is in the OFF position, the superstructure will rotate in the desired direction. Shifting the control to neutral and depressing the brake pedal will stop the swing.



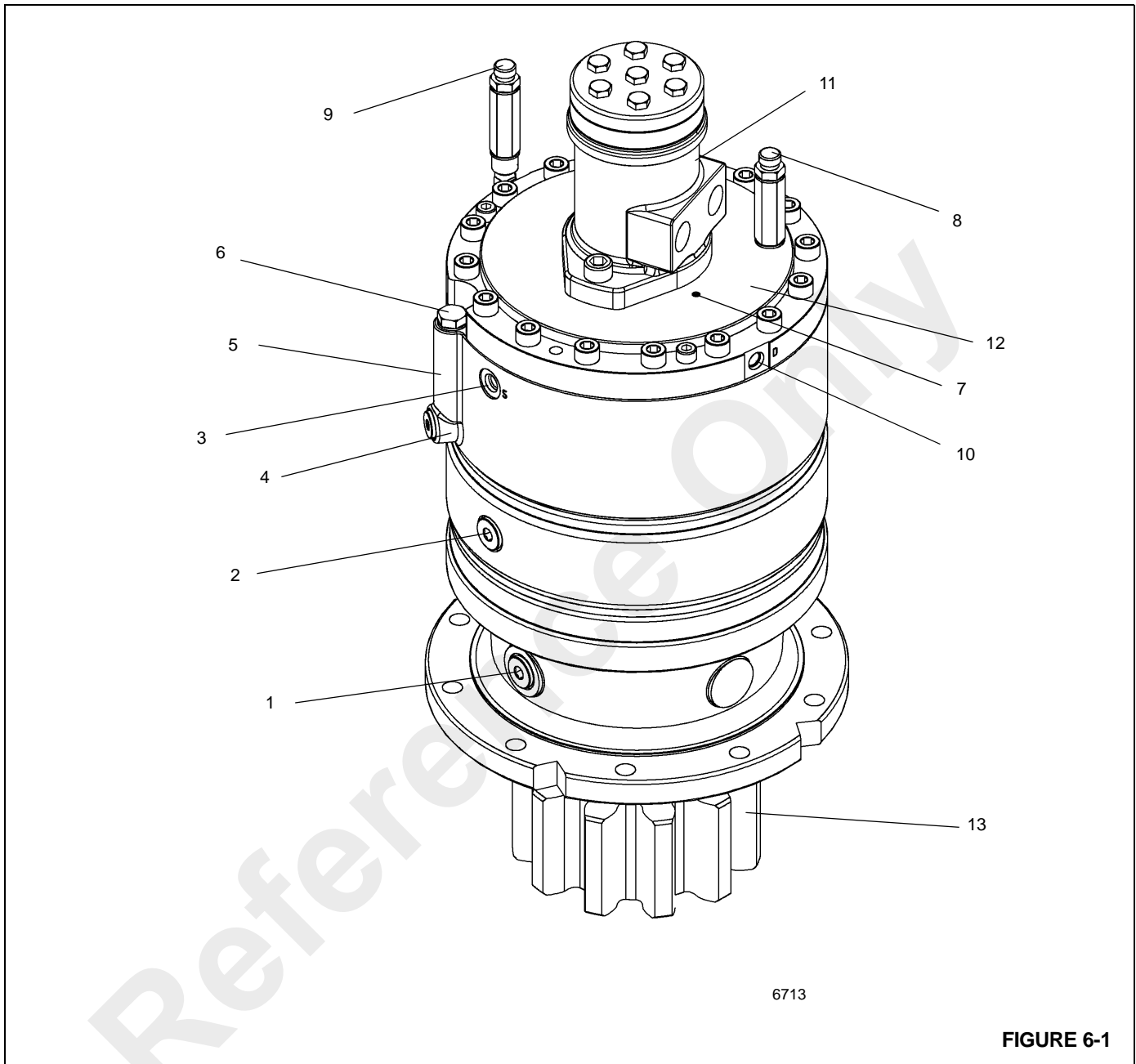

FIGURE 6-1

Item	Description
1	Plug
2	Plug
3	Plug
4	Elbow
5	Pipe
6	Breather
7	Plug

Item	Description
8	Dipstick
9	Breather
10	Plug
11	Motor
12	Gearbox and Brake
13	Pinion

Maintenance

Troubleshooting

Symptom	Probable Cause	Solution
1. Boom swing operation erratic in either direction.	a. Damaged relief valve.	a. Replace relief valve.
	b. Swing brake dragging (not releasing properly).	b. Readjust and/or replace necessary parts.
	c. Low engine rpm.	c. Increase engine rpm to obtain smooth swing operation.
	d. Low hydraulic oil.	d. Replenish hydraulic oil to proper level.
	e. Improper movement of control to neutral.	e. Feather controls to neutral to maintain smooth stopping action.
	f. Insufficient lubricant on swing bearing.	f. Lubricate bearing properly. Refer to Section 9 - LUBRICATION.
	g. Crane not level.	g. Level crane using outriggers.
	h. Damaged swing motor.	h. Repair or replace swing motor.
	i. Excessive overload.	i. Reduce load. Refer to load capacity chart.
	j. Restricted or partly clogged hydraulic hose or fittings.	j. Replace hose or fittings.
	k. Pump cavitation in swing section.	k. Tighten suction hose or replace any damaged fitting. Check hydraulic tank level.
	l. Improperly torqued turntable bolts.	l. Torque turntable bolts evenly.
	m. Excessive preload on upper and lower pinion shaft bearing.	m. Adjust as necessary.
	n. Improperly torqued swing motor attachment bolts.	n. Torque swing motor attachment bolts.
	o. Malfunction of the swing box.	o. Remove swing box and make necessary repairs.
	p. Worn or damaged pump.	p. Repair or replace damaged pump.
	2. Boom swing operation erratic in one direction only.	a. Crane not level.
b. Turntable bearing binding due to continuous limited swing. (Example: concrete pourer.)		b. Rotate machine 360 degrees in both directions several times and lubricate bearing.
c. Restricted hose or fitting.		c. Replace hose or fitting.
d. Damaged swing directional control valve.		d. Replace swing directional control valve.
e. Damaged swing pinion.		e. Replace pinion.
f. Damaged turntable bearing.		f. Replace turntable bearing.

Symptom	Probable Cause	Solution
3. Boom will not swing in either direction.	a. Damaged relief valve.	a. Remove, clean, and repair or replace relief valve.
	b. Damaged swing motor.	b. Repair or replace swing motor.
	c. Swing brake not releasing properly.	c. Repair as necessary.
	d. Damaged hydraulic remote control valve.	d. Replace hydraulic remote control valve.
	e. Internal damage to swing box.	e. Remove swing box and repair.
	f. Worn or damaged hydraulic pump.	f. Replace pump section.
	g. Damaged swing directional control valve.	g. Replace swing directional control valve.
	h. Damaged swing pinion.	h. Replace pinion.
	i. Damaged turntable bearing.	i. Replace turntable bearing.
	j. Excessive overload.	j. Reduce load. Refer to load capacity chart.
4. Swing operation slow in either direction.	a. Damaged relief valve.	a. Adjust, repair or replace valve.
	b. Improperly adjusted swing brake.	b. Readjust.
	c. Damaged hydraulic remote control valve.	c. Replace hydraulic remote control valve.
	d. Improperly lubricated swing bearing.	d. Lubricate bearing per recommendations.
	e. Improper size hose and/or fittings installed.	e. Refer to the Parts Manual.
	f. Clogged or restricted hydraulic hoses or fittings.	f. Clean or replace damaged parts.
	g. Worn or damaged output shaft bearings	g. Replace bearings.
	h. Worn or damaged swing motor.	h. Repair or replace motor.
	i. Worn or damaged hydraulic pump.	i. Repair or replace pump.
	j. Crane not level.	j. Level crane.
	k. Damaged swing directional control valve.	k. Replace swing directional control valve.
5. Swing operation slow in one direction only.	a. Crane not level.	a. Level crane.
	b. Damaged hydraulic remote control valve.	b. Replace hydraulic remote control valve.
	c. Damaged swing directional control valve.	c. Replace the swing directional control valve.
	d. Clogged or restricted hose.	d. Replace hose or fitting.
	e. Improperly torqued turntable bearing.	e. Torque turntable bearing.

Symptom	Probable Cause	Solution
6. Swing brake operation erratic.	a. Improper brake adjustment.	a. Adjust brake.
	b. Air in swing brake system.	b. Bleed brake system.
	c. Brake pedal not fully retracted.	c. Check brake pedal return spring; repair or replace spring.
	d. Dirty or glazed brake disc.	d. Clean or replace disc.
	e. Malfunction of the glide swing power brake valve.	e. Repair or replace glide swing power brake valve.
	f. Kinked or bent lines and/or hoses and fittings.	f. Straighten or replace as required.
7. Swing brake system will not operate.	a. Damaged swing brake release valve.	a. Replace release valve.
	b. Damaged glide swing power brake valve.	b. Repair or replace glide swing power brake valve.
	c. Internal damage to the swing brake assembly.	c. Repair or replace affected parts.
	d. Loose or restricted brake lines or fittings.	d. Tighten or replace lines and fittings.
8. Swing brake pedal is spongy.	a. Damaged glide swing power brake valve.	a. Repair or replace the glide swing power brake valve.
	b. Loose or restricted brake lines or fittings.	b. Tighten or replace brake lines and fittings.
9. Swing brake drags.	a. Damaged glide swing power brake valve.	a. Repair or replace the glide swing power brake valve.
	b. Damaged swing brake release valve.	b. Replace release valve.
	c. Internal damage to the swing brake assembly.	c. Repair or replace affected parts.
	d. Loose or restricted brake lines or fittings.	d. Tighten or replace brake lines and fittings.
10. Boom swings slowly.	a. Insufficient hydraulic volume.	a. Check delivery of hydraulic pump. Ensure sufficient fluid is available to pump. Check pump drive speed.
	b. Damaged relief valve.	b. Adjust, repair, or replace valve.
	c. Damaged swing motor.	c. Repair or replace motor.
11. Swing motor continues to operate when swing control is in neutral.	a. Hydraulic remote control valve sticking or valve otherwise damaged.	a. Repair or replace valve.
	b. Control valve sticking or valve otherwise damaged.	b. Repair or replace valve.
12. Swing motor turning in wrong direction.	a. Improper port connections.	a. Reverse port connection.
13. Swing motor noisy.	a. Air in system.	a. Refer to Section 2 - HYDRAULIC SYSTEM, for removal of air from the system.
	b. Motor binding.	b. Repair or replace motor.

SWING MOTOR

Description

The swing motor is mounted on the swing brake housing and drives the swing gearbox through the brake assembly. The swing motor is a hydraulic gerotor type with low speed and high torque characteristics. It has only three moving parts, the commutator valve, the drive, and the gerotor star. The motor has two ports for connection to the hydraulic system.

Maintenance

Removal

1. Ensure the swing brake and swing lock are engaged.
2. Clean the port area around the motor. Tag and disconnect the hydraulic hoses from the motor assembly. Cap or plug all openings.

CAUTION

Oil can be hot and can cause burns.

3. Remove the drain plug, loosen the filler and level plugs, and drain the oil. After oil is drained, replace the drain plug and any other plugs that may have been removed.

CAUTION

Pull straight up on the motor assembly to avoid damaging the splined shaft.

4. Remove the two screws securing the motor and lift the swing motor free of the flange. Remove and discard the O-ring from the groove in the swing brake.

Installation

CAUTION

Use care when engaging the swing motor drive gear, do not force the shaft to engage.

1. Install a new O-ring in the groove of the swing brake. Position the swing motor on the swing brake, engaging the shaft with the brake input shaft.
2. Apply Loctite 243 to the screw threads. Install the screws and secure the motor to the brake housing. Torque the screws 85 to 103 Nm (44 to 72 lb-ft).
3. Connect the hydraulic lines to the swing motor as tagged during removal.

Test

1. Test swing of superstructure in each direction. Stop and start swing several times.
2. Inspect for hydraulic leaks and repair as necessary.

SWING GEARBOX AND BRAKE

Description

The swing gearbox and brake, used in conjunction with the swing motor, rotates and stops the superstructure. A pedal on the cab floor is used to activate the swing brake. The swing gearboxes are bolted to the superstructure base plate, and its pinion gear meshes with the ring gear of the turntable bearing to rotate the turntable.

The swing gearbox utilizes double reduction planetary gearing. The multi-disc swing brake assembly is an integral part of the swing gearbox and is located between the swing motor and the swing gearbox. The brake mechanism is a disc pack that is hydraulically released and spring applied.

Maintenance

NOTE: The swing brake can be removed and disassembled independently of the swing gearbox.

Swing Brake

Removal

1. Engage the turntable lock pin.
2. Tag and disconnect the hydraulic lines connected to the swing motor and the brake. Cap and/or plug all openings.
3. Remove the swing motor from the swing brake according to the procedures found in this Section under SWING MOTOR - REMOVAL.

CAUTION

Use care when removing the capscrews securing the brake, as there is tension on the bolts due to internal brake springs.

4. Unscrew the screws securing the brake to the gearbox. Lift the brake using the brake flange, then remove the O-ring.
5. Cover the opening of the swing gearbox to ensure no dirt, dust, etc., gets into the gearbox.

Installation

1. Install a new o-ring onto the brake housing.
2. Apply Loctite 243 to the screws. Install brake onto gearbox and secure with the screws. Torque the screws 50 to 60 Nm (36.8 to 44.2 lb-ft).
3. Install the swing motor into the swing brake according to the procedures found in this Section under SWING MOTOR - INSTALLATION.
4. Connect the hydraulic lines to the motor and brake.

5. Bleed all air from the brake assembly.

Gearbox

Removal

1. Engage the turntable lock pin.
2. Tag and disconnect the hydraulic lines from the swing motor and swing brake. Cap and/or plug all openings.
3. Unscrew the three screws securing the pinion gear cover. Remove the cover.
4. Remove the gear from the shaft.

NOTE: The complete gearbox assembly with motor weighs approximately 126 kg (277.7 lb).

5. Attach a suitable lifting device to the swing gearbox. Remove the capscrews, flatwashers and bushings securing the gearbox to the mounting plate.

NOTE: Take note of the swing motor port orientation to ensure proper installation.

6. Remove the swing gearbox.
7. If necessary, remove the swing motor according to the procedures found in this Section under SWING MOTOR REMOVAL.
8. If necessary, remove the swing brake according to the procedures found in this Section under SWING BRAKE REMOVAL.
9. Cover the opening of the swing gearbox to ensure no dirt, dust, etc., gets into the gearbox.

Installation

1. If removed, install the swing brake according to the procedures found in this Section under SWING BRAKE INSTALLATION.
2. If removed, install the swing motor according to the procedures found in this Section under SWING MOTOR INSTALLATION.
3. Attach a suitable lifting device to the swing gearbox and lift and position the swing gearbox in place on the mounting plate.
4. Install the capscrews, flatwashers and bushings. Torque the capscrews 85 to 93 Nm (63 to 69 lb-ft).
5. Apply Loctite 243 to screws. Install the pinion gear on the output shaft. Install the cover and secure with three screws. Torque screws 50 Nm (36.8 lb-ft).
6. Connect the hydraulic lines to the swing brake.
7. Connect the hydraulic lines to the swing motor.
8. Service the gearbox as indicated under SERVICING.

Servicing

As with all highly stressed mechanisms, reasonable operating procedures are always required. Normal maintenance should only consist of proper lubrication and a periodic check of mounting bolt torque values. Lubrication consists of maintaining the gearbox oil level. Oil in a new gearbox should be drained and flushed out after approximately 250 hours of operation, and replaced with premium quality SSGL-5 (spec 6829012964) after approximately 500 hours of operation or each year, whichever occurs first. Operation in high humidity or polluted air areas will require more frequent changes to minimize moisture or contaminate accumulation. Change the oil as follows.

1. Unscrew the drain plug. To ensure all oil has been removed, unscrew the filler and level plugs.
2. After oil is drained, replace the drain plug and any other plugs that were removed to drain the oil.
3. Flush the case with a light flushing oil.

NOTE: Cleaning of the gearbox with a solvent is recommended to prevent an accumulation of grit and grime. Avoid steam cleaning where moisture and dirt might be driven into the vent of the swing bearing.

4. To refill with oil, fill through filler plug until it begins to flow out of the level plug.
5. Tighten the level and filler plugs.

Checking The Oil Level

1. Check the oil level through level plug.
2. If no oil is visible on the level plug, add oil until the level is between min and max on the level plug.
3. Refer to Section 9 - LUBRICATION.

Testing

1. Test swing of superstructure in each direction. Stop and start swing several times.
2. Inspect for hydraulic leaks and repair as necessary.

SWING BEARING

Description

The swing bearing is an anti-friction roller bearing that mates the Superstructure to the Carrier. The bearing inner race is bolted to the Superstructure and the outer race is bolted to the Carrier. The inner race contains two grease fittings for lubrication of the bearing which are hoses to two fittings at the front right side of the turntable center section.

Maintenance

General

The swing bearing is the most critical maintenance point of the crane. It is here, at the centerline of rotation, that stresses of loads are concentrated. In addition, the bearing provides the only attachment between the superstructure and carrier. Therefore, proper care of the bearing and periodic maintenance of the turntable-to-bearing attach bolts -IS A MUST -to ensure safe and efficient operation.

Torquing Turntable Bolts

General



DANGER

Failure to maintain proper torque of the turntable bearing attaching bolts will result in damage to the crane and possible injury to personnel.

Maintaining proper torque value for bolts is extremely important for structural strength, performance, and reliability of the crane. Variations in torque can cause distortion, binding, or complete separation of the superstructure from the carrier.

CAUTION

Repeated re-torquing may cause bolts to stretch. If bolts keep working loose, they must be replaced with new bolts of the proper grade and size.

Proper identification of bolt grade is important. When marked as a high strength bolt (grade 8 and metric grade 10.9), the serviceman must be aware of bolt classifications and that he is installing a high strength heat-treated tempered component and the bolt must be installed according to specifications. Special attention should be given to the existence of lubricant and plating that will cause variation from dry torque values. When a high strength bolt is removed, or un-torqued, the bolt must be replaced with a new bolt of the same classification.



DANGER

It is mandatory that bearing attaching bolts be inspected for lack of torque and retorqued, as required, after the first 300 hours of crane operation. The bolts may loosen in service due to vibration, shock-loads, and temperature changes, therefore, periodic inspection should be accomplished every 500 hours thereafter, ensuring the bolts are properly torqued.

KNOW YOUR TORQUE WRENCH! Flexible beam type wrenches, even though they might have a pre-set feature, must be pulled at right angle and the force must be applied at the center of the handle. Force value readings must be made while the tool is in motion. Rigid handle type, with torque limiting devices that can be pre-set to required values, eliminate dial readings and provide more reliable, less variable readings.

NOTE: If multipliers and/or special tools are used to reach hard to get at areas, ensure torque readings are accurate.

Torque wrenches are precision instruments and must be handled with care. To ensure accuracy, calibrations must be made on a scheduled basis. Whenever there is a possibility that a torque wrench may have been either overstressed or damaged, it should immediately be removed from service until recalibrated. When using a torque wrench, any erratic or jerking motion can result in the application of excessive or improper torque. **ALWAYS** use a slow, even movement and **STOP** when the predetermined value has been reached.

If it is reported by the crane operator or suspected that the crane has been overloaded beyond the capacities specified above the bold line on the cranes' capacity chart, then all turntable bolts must be inspected for looseness and retorqued to specifications.

Turntable bolts should be torqued according to the procedures outlined in this section.

When using step wrenches, calculated wrench settings are valid only when the following conditions are met.

1. Torque wrenches must be those specified and forces must be applied at the handle grip. The use of handle extensions will change applied torque to the bolt.
2. All handles must be parallel to the step wrench during final tightening. Multiplier reaction bars may be misaligned no more than 30 degrees without causing serious error in torque.
3. Multiplier bar handles must be propped or supported within the outer 1/4 of the handle length, or serious under or over tightening will occur.

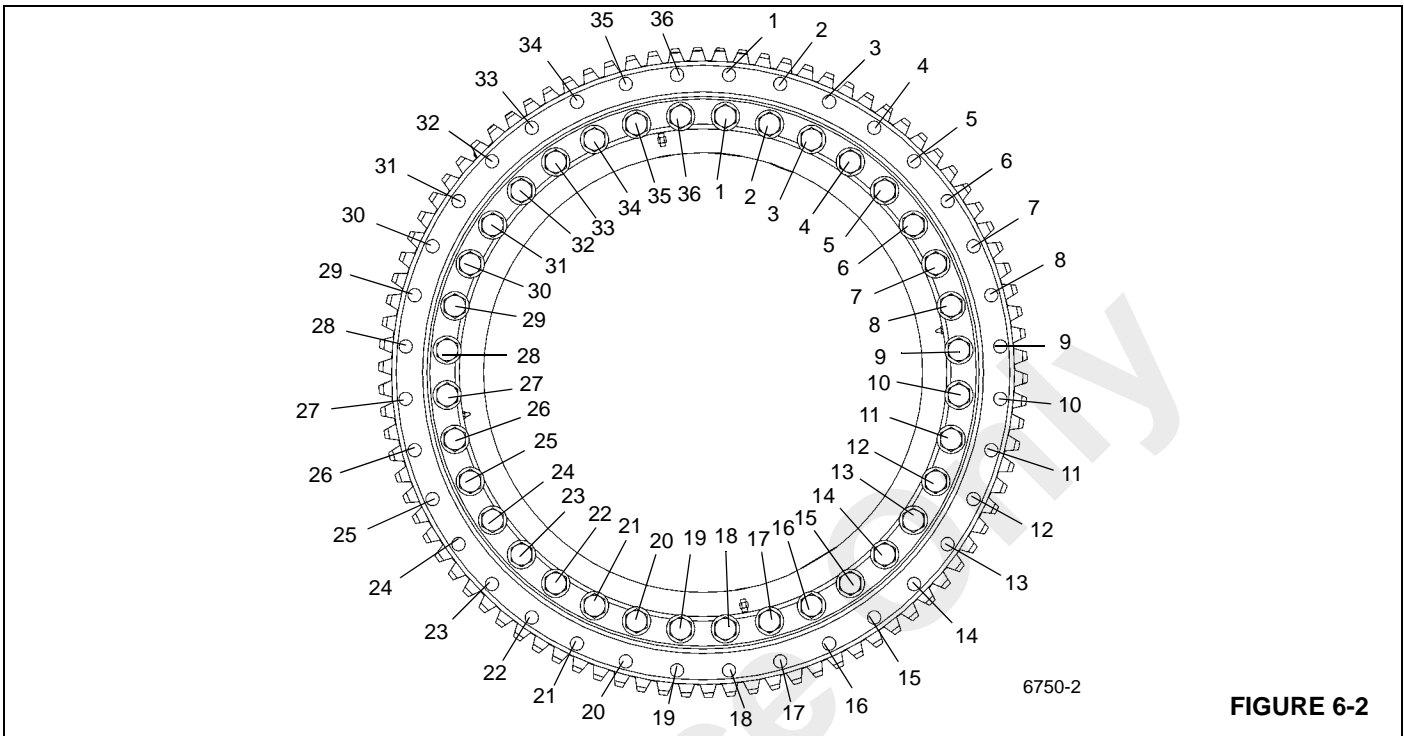

FIGURE 6-2

The inner race of the bearing is secured to the turntable by 36, 1 inch, grade 8 bolts. The outer race of the bearing is secured to the carrier frame by 36, 7/8 inch, grade 8 bolts.

Torque Values

Torque all inner race turntable bolts (Figure 6-2) to a final torque of 1162 to 1260 Nm (857 to 929 lb-ft).

Torque all outer race turntable bolts (Figure 6-2) to a final torque of 769 to 834 Nm (567 to 615 lb-ft).

See Fasteners and Torque Values (pg 1-11).

Tools Required

(Figure 6-3) lists the complete set of special tools required to torque the turntable bolts.

Inner Race Torquing

1. Extend and set the outriggers. Fully elevate the boom.
2. Torque eight bolts 930 to 1008 Nm (686 to 743 lb-ft) using the following sequence pattern; 36, 18, 10, 28, 5,

23, 14, and 32. Tools used are the socket, multiplier, backlash adapter, necessary extensions, and torque wrench.

3. Return to bolt 1 and torque all bolts sequentially in a clockwise direction to the final torque of 1162 to 1260 Nm (857 to 929 lb-ft). The same tools are used as in step 1.

Outer Race Torquing

1. Extend and set the outriggers. Fully elevate the boom.
2. Torque eight bolts 615 to 667 Nm (454 to 492 lb-ft) using the following sequence pattern; 36, 18, 10, 28, 5, 23, 14, and 32. Tools used are the socket, multiplier, backlash adapter, necessary extensions, and torque wrench.
3. Return to bolt 1 and torque all bolts sequentially in a clockwise direction to the final torque of 769 to 834 Nm (567 to 615 lb-ft). The same tools are used as in step 1.

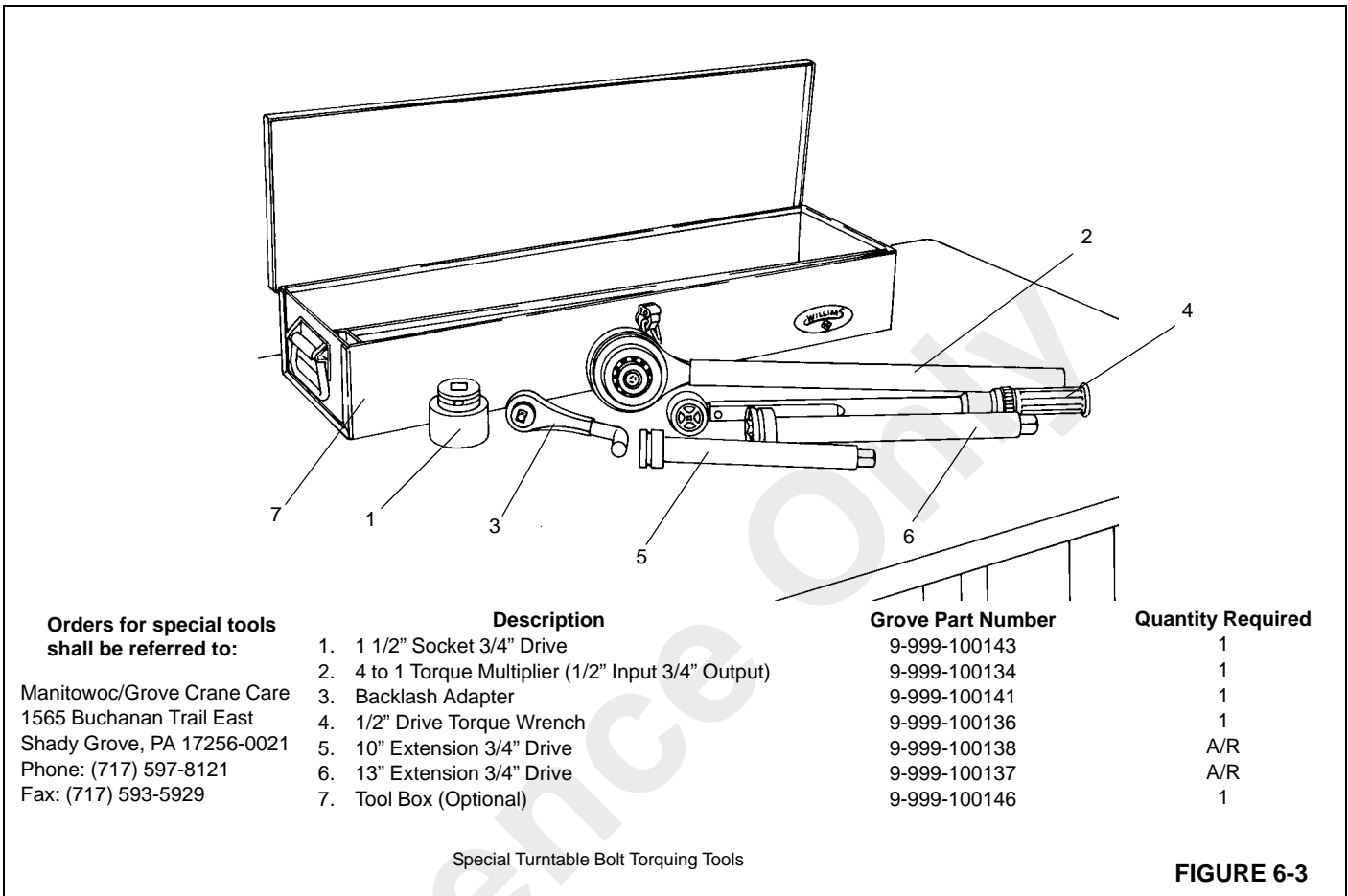

Removal

1. Fully extend and set the outriggers enough to take up the slack in the pads.

NOTE: Do not raise the machine on the outriggers.

2. Ensure the boom is in the travel position and the turntable lock pin is engaged.
3. Elevate the boom slightly and shut down the engine.
4. Tag and disconnect the battery cables from the batteries.

NOTE: The boom assembly weighs approximately 5792 kg (12,769 lb) with stowed boom extension. Removal of the swingaway boom extension will simplify boom removal, therefore, the above weight is for the boom without the swingaway boom extension attached. The lift cylinder weighs approximately 578 kg (1274 lb).

5. Remove the boom and lift cylinder following the procedures outlined in Section 4, BOOM.

6. Remove the counterweight and auxiliary hoist following procedures outlined in Section 5 - HOIST and COUNTERWEIGHT.
7. Tag and disconnect all water and oil lines from the bottom of the swivel. Cap or plug all lines and openings.
8. Locate the connectors and ground wire that joins the swivel wiring harness to the receptacles and ground stud on the carrier.
9. Disconnect the swivel wiring harness connectors from the carrier wiring receptacles. Remove the ground wire from the ground stud.
10. Remove the clamp securing the swivel wiring harness to the retainer plate on the bottom of the hydraulic swivel assembly.
11. Coil the wiring harness and secure it to the swivel to prevent damage to the harness during turntable removal.
12. On the bottom of the hydraulic swivel, bend the retainer tabs away from the capscrew heads. Remove the capscrews securing the two retainer plates to the spool.

Remove the retainer plates from the spool and the lugs on the carrier frame.

NOTE: The swivel assembly will be removed with the turntable.



DANGER

Ensure the lifting device is capable of fully supporting the weight of the superstructure. Ensure the superstructure will not tilt or slide during lifting and moving. Failure to do so may result in death or injury to personnel and damage to equipment.

NOTE: If a lifting device capable of lifting the entire superstructure is not available, superstructure weight may be reduced by removing various components such as the hoist(s).

13. Attach a suitable lifting device to the four superstructure lifting lugs (two near the boom pivot shaft bushings and two near the lower lift cylinder pivot shaft bushings). Take in cable or chain to remove slack. Do not pull up on the superstructure.



DANGER

Ensure the superstructure is fully supported before proceeding.

NOTE: It will be necessary to rotate the superstructure while attached to the lifting device. Outer race bolts can only be removed from the swing drive side of the turntable.

14. Remove the 36 bolts and washers securing the turntable bearing outer race to the carrier.



DANGER

Ensure that any blocking material used is capable of fully supporting the weight of the superstructure and will not allow it to tilt or shift. Failure to do so may result in death or injury to personnel.

15. Carefully lift the superstructure, using care not to damage the swivel assembly, and set it on blocking that will not allow the superstructure to tilt or shift, or rest on the swivel. Leave the lifting device attached.

NOTE: If the same bearing is to be used again, mark the position of the bearing on the superstructure so it can be installed in the exact position it was before removal.

NOTE: The bearing weighs approximately 260 kg (573 lb). Ensure the bearing lifting device is capable of supporting the weight.

16. Place an adequate lifting device under the bearing and remove the 36 bolts and washers securing the turntable bearing to the superstructure.
17. Using the lifting device, remove the turntable bearing from under the superstructure.

Inspection

Check the bearing teeth for chipping or cracking. If any evidence of these is found, replace the bearing. Ensure the bolt holes are free of dirt, oil, or foreign material.

Installation



DANGER

Anytime a turntable bolt has been removed, it must be replaced with a new bolt.

NOTE: If the same bearing is to be used again, align the marked teeth on the pinion shaft and the marked teeth on the bearing.

NOTE: Installation is in the travel position. Ensure the swing lock is disengaged before attempting to mate the bearing to the superstructure.

1. Using an appropriate lifting device, position the turntable bearing under the superstructure. If the same bearing is being used, position it as marked prior to removal.
2. Install 36 new bolts and washers securing the bearing to the superstructure. Refer to Inner Race Torquing in this Sub-Section.
3. Using an appropriate lifting device, align the superstructure over the carrier in the travel position and carefully lower the superstructure, being careful not to damage the swivel assembly, into position on the carrier bearing plate.

NOTE: It will be necessary to rotate the superstructure while attached to the lifting device. Outer race bolts can only be installed from the swing drive side of the turntable.

4. Install 36 new bolts and washers. Refer to Outer Race Torquing in this Sub-Section.

NOTE: If a new bearing is being installed, a new pinion gear must also be used. Align the high point (maximum eccentricity) on the bearing with the new pinion gear high point (Figure 6-4).

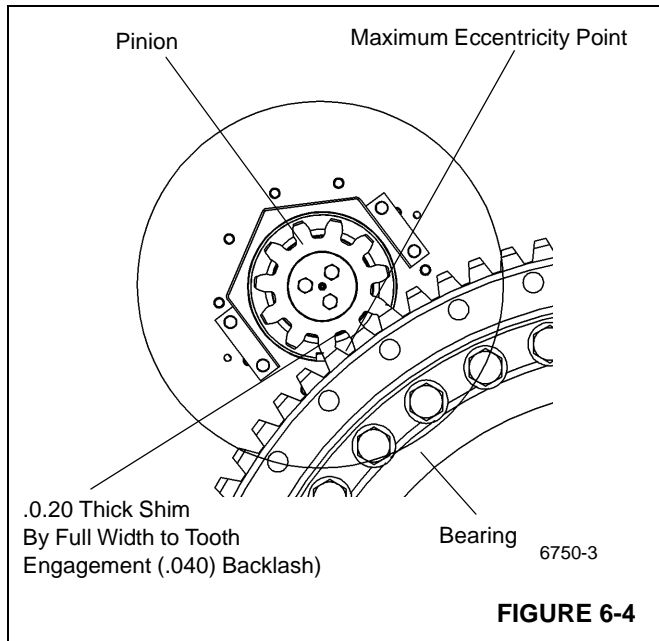

Orient ring gear such that its point of max eccentricity (“high point”) is located between the swing drives. Position swing drives so that pinion is centered within cutout in base plate and motor ports face towards the outboard side as shown.

CAUTION

Do Not Clamp Over Pinion.

- Using shims, set backlash by moving the swing drive assemblies toward the bearing in order to mesh the pinion with the ring gear teeth (see Figure 6-5).
- Check tooth engagement squareness and vertical tooth engagement.
- Remove backlash shims and recheck backlash.

5. Apply Loctite 271 to the capscrews. Position the two retainer plates on the bottom of hydraulic swivel spool, engaging the lugs on the carrier frame, and secure them to the spool with four capscrew retainers and bolts. Torque the bolts 298 to 322 Nm (220 to 237 lb-ft). Bend all the retainer tabs to make contact with the bolt heads.
6. Plug the swivel wiring harness connectors into the carrier receptacles. Secure the ground wire to the ground stud using a washer, lockwasher, and nut.
7. Install the clamp securing the swivel wiring harness to the retainer plate on the bottom of the hydraulic swivel.
8. Connect all water and hydraulic lines to the ports on the bottom of the swivel as tagged during removal.
9. Install the boom and lift cylinder following the procedures outlined in Section 4, BOOM.

NOTE: The counterweight structure weighs approximately 3818 kg (8417 lb).

10. Install the counterweight and auxiliary hoist following procedures outlined in Section 4 of the Operator Manual.
11. Reconnect the batteries.
12. Check the slew potentiometer in the electrical swivel for proper orientation. Refer to SWIVELS in this Section

Testing

Activate the crane and check for proper function.

NOTE: If the superstructure does not turn freely after bearing and pinion replacement, contact your local distributor.

SWIVELS

Description

The swivel assembly (Figure 6-5) consists of a 10 port hydraulic swivel, a 2 port water swivel, a 2 port refrigerant swivel and a 20 conductor slip ring electrical swivel. Solid connections cannot be used to transfer oil, heater hot water and electricity between the carrier and superstructure due to the continuous 360 degree swing. The use of swivels efficiently accomplishes this function.

The barrel portion of the hydraulic swivel is attached to the turntable base plate by four capscrews, washers and bushings. The spool portion of the swivel rides upon a thrust ring at the top of the swivel case. The spool portion is held stationary with the carrier by bolts, and bolt retainer plates attached to the swivel retainer plate which engages the carrier frame lugs with capscrews and hex nuts. This allows

the spool to remain stationary with the carrier as the case rotates with the superstructure.

The spool portion of the water swivel is integral with the hydraulic swivel. The hydraulic and water swivel spools remain stationary with the carrier as the superstructure rotates. The water swivel case engages to hydraulic case by four dowel pins.

The electrical swivel center or collector ring assembly is secured by setscrews to a center post which is bolted to the spool of the hydraulic swivel. This allows the collector ring assembly to remain stationary with the carrier. The outer portion or brush assembly is mounted on two studs which are located on the mounting plate assembly which is retained to the water swivel barrel by a bolt. This allows the brush assembly to rotate with the superstructure around the stationary collector core.

Item	Description
1	Slip Ring Assembly
2	Capscrew
3	Washer
4	Hydraulic Swivel
5	Retaining Plate
6	Capscrew
7	Hex Nut
8	Adapter
9	Hose Nipple
10	Adapter
11	Plate
12	Capscrew
13	Jam Nut
14	Flatwasher
15	Capscrew
16	Hose Nipple
17	Adapter
18	Turntable Base Plate
19	Carrier Top Plate
20	Capscrew
21	Washer
22	Bushing
23	Plug
24	Retaining Plate

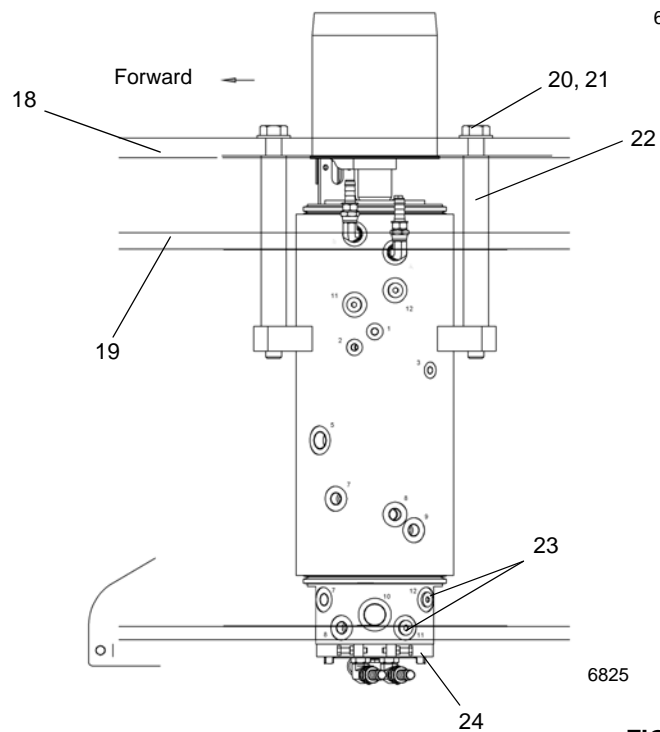
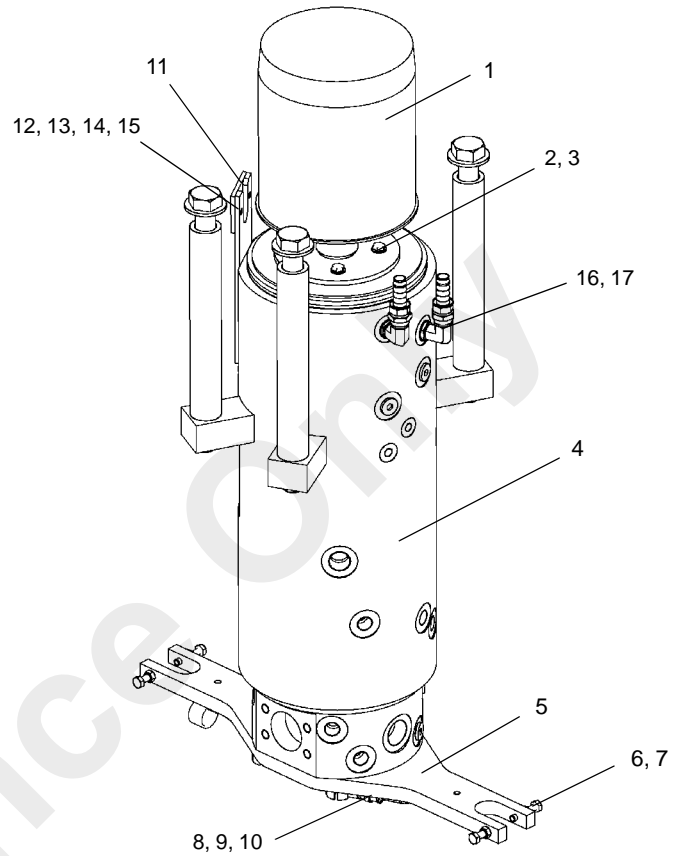

FIGURE 6-5

Hydraulic Swivel

Description

Each of the ports on the spool and case of the swivel is stamped with the port number. The function of each port is described below.

Port #	Max Test Pressure bar (psi)	Function
1	25000 (250) (3625)	Brake - Front
2	25000 (250) (3625)	Load Sense
3	25000 (250) (3625)	Brake - Rear
4	5000 (50) (725)	Dual Return
5	30000 (300) (4351)	Swing/Brake/Steer
6	32000 (320) (4641)	Lift/Tele/Hoist
7	25000 (250) (3625)	Front Steer - Left
8	25000 (250) (3625)	N/A
9	25000 (250) (3625)	Front Steer-Right
10	500 (5) (73)	Case Drain
11	500 (5) (73)	A/C
12	500 (5) (73)	A/C
A	500 (5) (73)	Heater Supply (Coolant)
B	500 (5) (73)	Heater Return (Coolant)

Theory of Operation

The hydraulic swivel allows oil to flow from the pumps to various crane functions on the superstructure. All oil is routed into the spool portion of the swivel where, through a series of internally drilled passages, oil is transferred to circumferential channels on the spool exterior. These channels correspond with a mating port on the outer case of the swivel. Each channel is separated by a series of nylon and O-ring seals that prevent transfer of oil and pressure. Return flow from the crane superstructure is accomplished in the same manner through another set of ports.

Engine coolant flows from the carrier mounted engine to the hot water heater in the operator cab through ports A and B of the swivel.

Maintenance

Removal

1. Extend and set the outriggers. Ensure the crane is level and the boom is over the front.
2. Elevate the boom and note at what boom angle you have the most clearance between the lift cylinder and the turntable side plate. Shut down the engine.

3. Measure the distance from the top of the lift cylinder to the base of the boom section where the lift cylinder attaches. Cut two pieces of 10 x 10 cm (4 x 4 in) oak to fit.

NOTE: It might be necessary to raise the boom slightly to allow installation of the blocking.

NOTE: This blocking is to add extra support for the boom. Any seepage or leakage in the holding valves or internally in the cylinders will allow the boom to settle over a period of time.

4. Use the oak blocking to block between the barrel of the lift cylinder and the boom base section.
5. Evacuate A/C system and capture refrigerant.
6. Tag and disconnect the hydraulic lines from the case of the hydraulic swivel. Cap or plug all lines and openings.
7. Tag and disconnect the hydraulic lines and water lines from the spool of the hydraulic swivel. Cap or plug all lines and openings.
8. Tag and disconnect the water lines from the case of the water swivel. Cap or plug all lines and openings.

9. Disconnect the swivel wiring harness connectors from the carrier receptacles and the yellow ground wire from the connector mounting bracket on the carrier frame. If necessary, remove the electrical swivel. Refer to *Electrical Swivel* in this Section.

NOTE: The hydraulic swivel weighs approximately 214 kg (472 lb). The hydraulic, water, and electrical swivel combined weigh approximately 243 kg (536 lb).

10. On the bottom of the swivel, bend the retainer tabs away from the capscrews. Remove the capscrews and capscrew retainers securing the two retainer plates to the spool. Remove the retainer plates from the spool and the lugs on the carrier frame.

NOTE: It may be necessary to remove some drive line components to remove the swivel.

11. Position an adequate supporting device beneath the swivel.
12. Remove the capscrews, washers, and bushings securing the swivel barrel to the turntable base plate and lower the swivel to the ground.

Installation

NOTE: The hydraulic swivel weighs approximately 214 kg (472 lb). The hydraulic, water, and electrical swivel combined weigh approximately 243 kg (536 lb).

1. Raise the swivel into position.
2. Secure the hydraulic swivel to the turntable base plate with the bushings, capscrews and washers. Torque the capscrews see Fasteners and Torque Values (pg 1-11) 714 to 774 Nm (526 to 571 lb-ft).

3. Apply Loctite 271 to the capscrews. Position the two retainer plates on the bottom of hydraulic swivel spool, engaging the lugs on the carrier frame, and secure them to the spool with four capscrew retainers and bolts. Torque the bolts 298 to 322 Nm (220 to 237 lb-ft). Bend all the retainer tabs to make contact with the bolt heads.

4. If removed, install the electrical swivel. Refer to ELECTRICAL SWIVEL in this Section. Connect the swivel wiring harness connectors to the carrier receptacles and the yellow ground wire to the mounting bracket on the carrier frame. Use the bolt and star washers taken off at removal and refer to Grove Engineering Specification A-829-100386 for proper electrical termination of grounds.

NOTE: Allow a 1/32" max gap between bolt and the retaining lug on the frame. Do not tighten bolt against lug.

5. Install the clamp, lockwasher, flat washer and capscrew to the bottom of the swivel retainer plate securing the wiring harness.
6. Connect the hydraulic lines and water lines to the spool of the hydraulic swivel as tagged during removal.
7. Connect the hydraulic lines to the hydraulic swivel case as tagged during removal.
8. Connect the water lines to the water swivel case as tagged during removal.
9. Remove the blocking material from the lift cylinder.
10. Activate all systems; cycle all functions and observe for proper operation and any leakage.
11. Charge A/C system.

Electrical Swivel

Description

The swivel assembly consists of a 20 conductor slip ring and cover assembly.

Each brush set incorporates two brushes, leads, and clips which are attached to a brush holder assembly. The brush set leads are formed into harnesses which are routed through the mounting plate on the swivel. The collector ring leads are formed into one harness which is routed downward through the center of the hydraulic swivel. Extending from the base of the hydraulic swivel, the collector ring leads are also formed into connectors which plug into receptacles from the chassis power supply.

The swivel cover is secured with a seal and bolts

The electrical swivel also incorporates a slew potentiometer. The potentiometer controls functions in the load moment indicating, working area definition, and rear axle oscillation lockout systems.

Theory of Operation

The electrical swivel is located on top of the water swivel and transfers electricity between the carrier and superstructure. Wiring harnesses transmit the electricity between the carrier and superstructure.

Maintenance

Removal

1. Perform steps 1 through 4 of HYDRAULIC SWIVEL - REMOVAL in this section.



CAUTION

Disconnect the batteries before performing any maintenance on the electrical system. Serious burns may result from accidental shorting or grounding of live circuits.

2. Disconnect the batteries. Refer to Section 3 - ELECTRIC SYSTEM.
3. Locate the connectors which join the collector ring harness to the receptacles for the carrier.
4. Tag the connectors and their receptacles with numbers. Disconnect the connectors from the chassis wiring receptacles.
5. Remove the clamp securing the wiring harness to the retainer plate on the bottom of the hydraulic swivel assembly.

6. Secure the connectors and wires from each of the numbered connectors so the harness can be withdrawn through the center of the hydraulic swivel.
7. Tag and disconnect the connectors from the receptacles on the cab bulkhead mounting plate.
8. Remove the setscrews and remove the cover from the electrical swivel.
9. Loosen the capscrews securing the electrical swivel mounting tube to the center post on the water swivel.
10. Remove the capscrew and jam nut securing the electrical swivel case to the plate on the case of the water swivel.

CAUTION

When withdrawing the wiring harness through the center of the hydraulic and water swivels, ensure the wires do not get caught and damaged.

11. Remove the swivel and wiring harness from the crane. If necessary, remove the spacer bushing from the center post.

Installation

1. If removed, install the spacer bushing on the center post. Route the collector core wiring harness through the center of the hydraulic and water swivels.

NOTE: The boom should be centered directly over the front of the crane before adjustment is made to the slew potentiometer.

2. Slide the electrical swivel mounting shaft onto the center post.
3. Ensure the threaded hole on the bottom of the electrical swivel base is aligned with the mounting hole in the plate on the water swivel case. Install the capscrew through the hole in the plate and install the jam nut. Screw the capscrew into the hole in the electrical swivel base until the capscrew head is approximately 6.0 mm (0.23 in) from the bracket. Tighten the nut against the electrical swivel (Figure 6-6).
4. Apply medium strength Loctite to the setscrews securing the electrical swivel to the center post and tighten them 5 to 6 Nm (44 to 53 lb-in)
5. Install the swivel cover and secure with capscrews and washers.
6. Connect the wiring harness connectors to the receptacles on the cab bulkhead mounting plate as tagged during removal.

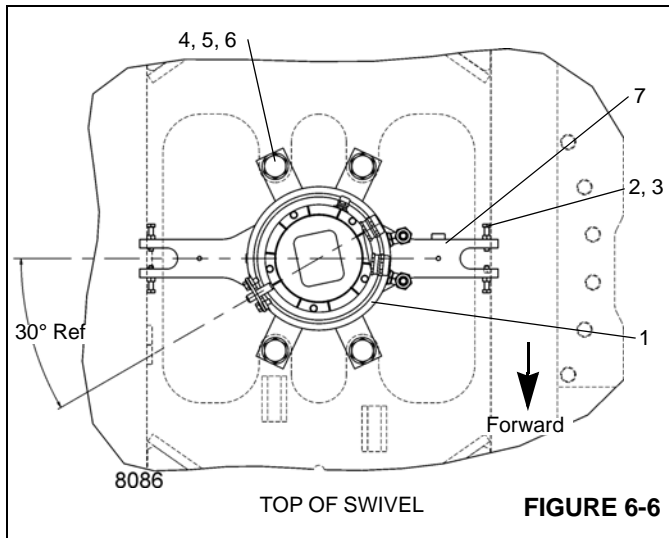

FIGURE 6-6

Item	Description
1	Swivel
2	Capscrew
3	Hex Nut
4	Capscrew
5	Washer
6	Bushing
7	Retaining Plate

7. Plug the connector into the carrier wiring receptacle, connect the wires as tag during removal. Install the yellow ground wire to the connector mounting bracket on the carrier frame using the bolt and star washers taken of at removal and refer to Grove Engineering Specification A-829-100386 for proper electrical termination of grounds.
8. Install the clamp securing the harness to the retainer plate on the bottom of the hydraulic swivel assembly.
9. Connect the batteries.

CAUTION

It is imperative that the slew potentiometer be adjusted anytime work is done to the electrical swivel.

10. Activate all systems, cycle all functions, and observe for proper operation. Adjust the slew potentiometer in accordance with SLEW POTENTIOMETER ADJUSTMENT procedures in this Sub-Section.

Preventive Maintenance

It is recommended that a normal inspection of the electrical swivel collector ring and brush assembly be established. An example of this could be at approximately 100 to 150 engine

operating hours. When this time limit is reached, perform the following.

1. Check the collector ring and brush assembly for any corrosion, pitting, arcing, and wear.
2. Check the collector ring setscrews and ensure they are tight.
3. Check the brush and arm assembly springs. Ensure they are holding the brushes firmly against the collector rings.

Slew Potentiometer Adjustment

1. Rotate the superstructure over the front and engage the house lock pin.
2. Remove the electrical swivel cover.

CAUTION

Do not attempt to rotate the slotted shaft in the center of the slew potentiometer.

3. Disengage the house lock pin and swing the superstructure approximately 10 degrees to the right (clockwise). Slowly swing back to the left and engage the house lock pin.

NOTE: If the superstructure swings past the house lock pin engaged position, step 3 must be repeated.

4. Loosen the three screws that secure the slew potentiometer to the mounting plate.
5. Rotate the body of the slew potentiometer until the slew angle indicates 0.6 ± 0.1 degree.

NOTE: The slew angle indication in step 6 may not be obtainable due to limited wire length on the potentiometer, or the electrical terminals interference with one of the three mounting screws. If this occurs, reposition the collar set screwed to the potentiometer shaft and repeat steps 3 thru 5.

6. Tighten the three screws that secure the slew potentiometer to the mounting plate. Install the electrical swivel cover.

7. Disengage the house lock pin and swing approximately 10 degrees to the left (counterclockwise). Slowly swing back to the right and engage the house lock pin.

NOTE: If the superstructure swings past the house lock pin engaged position, step 7 must be repeated.

8. If the angle indicated on the console does not exceed ± 1.0 degree, proceed to step 10. If the indicated angle exceeds ± 1.0 degree, return to step 3.

9. Disengage the house lock pin and swing approximately 10 degrees to the right (clockwise). Slowly swing back to the left and engage the house lock pin.

NOTE: If the superstructure swings past the house lock pin engaged position, step 10 must be repeated.

10. If the angle indicated on the console does not exceed ± 1.0 degree, proceed to step 12. If the indicated angle exceeds ± 1.0 degree, return to step 3.

11. Disengage the house lock pin and swing approximately 10 degrees to the left (counterclockwise). Slowly swing back to the right and engage the house lock pin.

NOTE: If the superstructure swings past the house lock pin engaged position, step 12 must be repeated.

12. Verify the angle indicated on the console does not exceed ± 1.0 degree. If the indicated angle exceeds ± 1.0 degree, return to step 3.

Reference Only

SECTION 7 POWER TRAIN

SECTION CONTENTS

<p>Engine 7-1</p> <p style="padding-left: 20px;">Description 7-1</p> <p style="padding-left: 20px;">Maintenance 7-2</p> <p>Fuel System 7-7</p> <p style="padding-left: 20px;">Description 7-7</p> <p style="padding-left: 20px;">Maintenance 7-7</p> <p>Air Intake and Exhaust System 7-9</p> <p style="padding-left: 20px;">Description 7-9</p> <p style="padding-left: 20px;">Air Intake 7-9</p> <p style="padding-left: 20px;">Charge-Air Cooler System 7-13</p> <p style="padding-left: 20px;">Muffler and Diesel Oxidation Catalyst - Tier 4 Interim 7-14</p> <p style="padding-left: 20px;">Slip Joint Exhaust Connectors 7-14</p> <p>Water Cooling System 7-16</p>	<p style="padding-left: 20px;">Description 7-16</p> <p style="padding-left: 20px;">Maintenance 7-16</p> <p style="padding-left: 20px;">Test Equipment 7-19</p> <p style="padding-left: 20px;">Antifreeze/Coolant 7-19</p> <p style="padding-left: 20px;">Radiator Removal and Installation 7-19</p> <p>Drive Train 7-21</p> <p style="padding-left: 20px;">Description 7-21</p> <p style="padding-left: 20px;">Maintenance 7-21</p> <p style="padding-left: 20px;">Transmission/Torque Converter 7-21</p> <p style="padding-left: 20px;">Description 7-21</p> <p style="padding-left: 20px;">Theory of Operation 7-21</p> <p style="padding-left: 20px;">Maintenance 7-22</p> <p style="padding-left: 20px;">Servicing the Crane After Transmission/Torque Converter Overhaul 7-25</p>
---	---

ENGINE

Description

The engine is a Cummins QSB6.7 (Figure 7-1) Tier 3 or Tier 4i diesel engine. This Service Manual does not include detailed information on the engine itself. A separate manual as prepared in detail by the engine manufacturer, is supplied with this Service Manual. However, a short description and maintenance of certain components of the fuel system, air intake system, and water cooling system is provided in this section.

The engine is electronically controlled by the Electronic Control Module (ECM), it is the control center of the system. It processes all of the inputs and sends commands to the fuel systems as well as vehicle and engine control devices.

Engine speed is controlled by the foot throttle pedal in the cab. It controls engine RPM which increases or decreases proportionately with the amount of foot pressure applied to the pedal. The foot throttle pedal is electrically connected to the superstructure control module which sends the signal to the engine ECM via the J1939 data link.

The engine and its components are enclosed in a hood assembly with a grill in the rear of the hood for adequate air

circulation. Access to the engine is gained through a door assembly in the right side of the hood.

The air intake filter is mounted on the rear of the left rear fender. The muffler is mounted on the left side of the hood behind the rear fender.



DANGER

Do not spray starting fluid into the air inlet. The spray will contact the heater elements and could explode causing personal injury.

To aid in starting the engine in cold weather, the engine is equipped with electric air heating elements that are located in the engine's intake air stream to aid in cold starting and reduce white smoke at start-up. In the preheat mode, the engine should not be cranked until the WAIT-TO-START lamp turns off. The WAIT-TO-START lamp is illuminated during the preheat time that takes place when the ignition switch is in the ON position during cold weather starting. The ECM checks intake manifold temperature to determine how long to energize the air heater before extinguishing the WAIT-TO-START lamp. Once the engine is started, the electric air heating element will be energized again for a time period determined by intake air temperature.

Maintenance

Engine Removal

1. Set the outriggers and position the boom to over the side.
2. Open and remove the hood door assembly.
3. Disconnect the air filter tubing at the engine and air cleaner. Remove and lay aside.
4. Disconnect the exhaust tubing at the engine and muffler. Lay to the side.
5. Tag and disconnect the engine electrical harness connector from the carrier harness connector and battery cables.
6. Remove the start and grid heater relay panel and place to the side of the frame. Lay the relay panel with the harness on the engine. If a remote crank option is present, disconnect the remote crank harness connector from the engine harness and tie up excess harness so it is out of the way.
7. Drain the engine coolant system.
8. Drain the engine lubrication system.
9. Drain the transmission/torque converter oil system.
10. Evacuate A/C system and capture refrigerant.
11. Remove the engine hood assembly and pump cover from the machine.
12. Disconnect and remove the drive shaft(s) between the transmission/torque converter and the axle(s). Refer to DRIVE LINES in this Section.
13. Tag and disconnect all lines from the radiator. Disconnect the coolant level sensor harness from the

engine harness and tie up excess harness so it is out of the way. Remove the radiator. Refer to Radiator Removal and Installation (pg 7-19) I in this Section.

14. Tag and disconnect all lines and tubing from the engine, transmission/torque converter, and all other components.



DANGER

The lifting device must be able to support the combined weight of the engine and transmission.

NOTE: The engine and transmission/torque converter assembly weighs approximately 1200 kg (2646 pounds).

15. Attach to the engine a lifting device capable of supporting the weight of the engine and transmission/torque converter.
16. With the lifting device supporting the weight of the engine, remove the capscrews, washers and locknuts securing the front of the engine to the frame.
17. Remove the capscrews, washers, nuts, insulator and mounting plate securing the rear of the engine to the frame.
18. Using the lifting device, lift the engine and transmission/torque converter as an assembly from the crane.
19. If a new engine is to be installed, remove all components, fittings, etc., from the old engine and install them on the new engine in the same locations.

NOTE: Ensure that the same grade hardware, torque values, and Loctite as were installed by the factory are used.

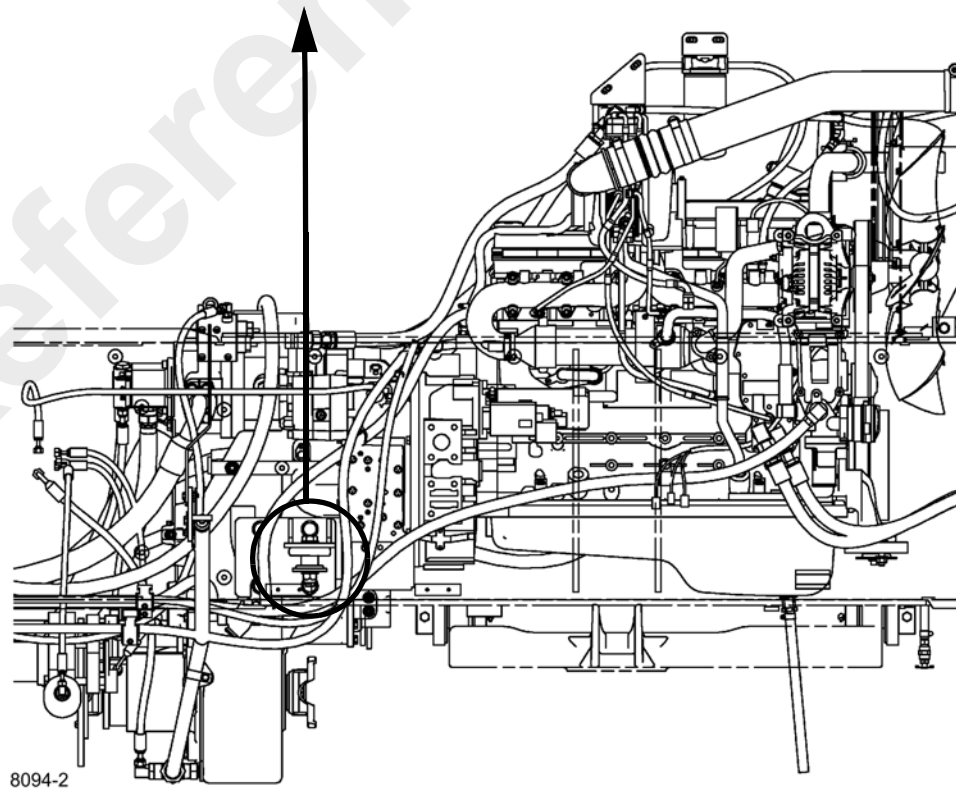
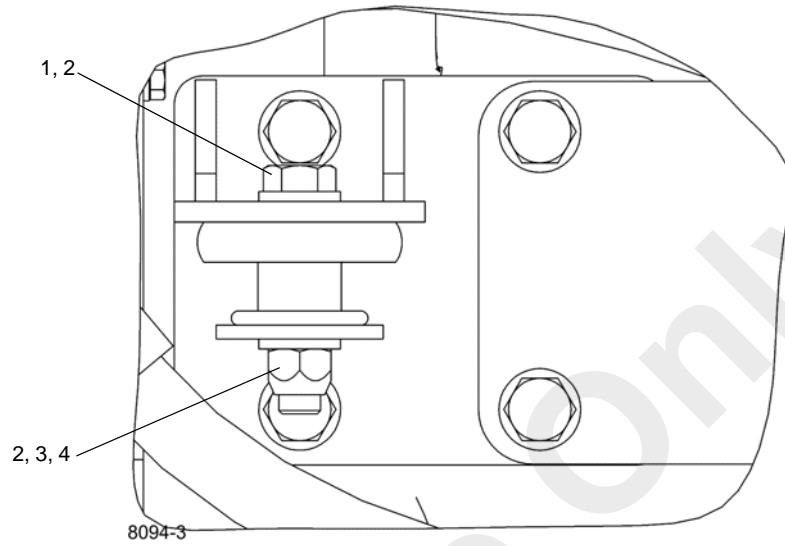

View Of Engine

FIGURE 7-1

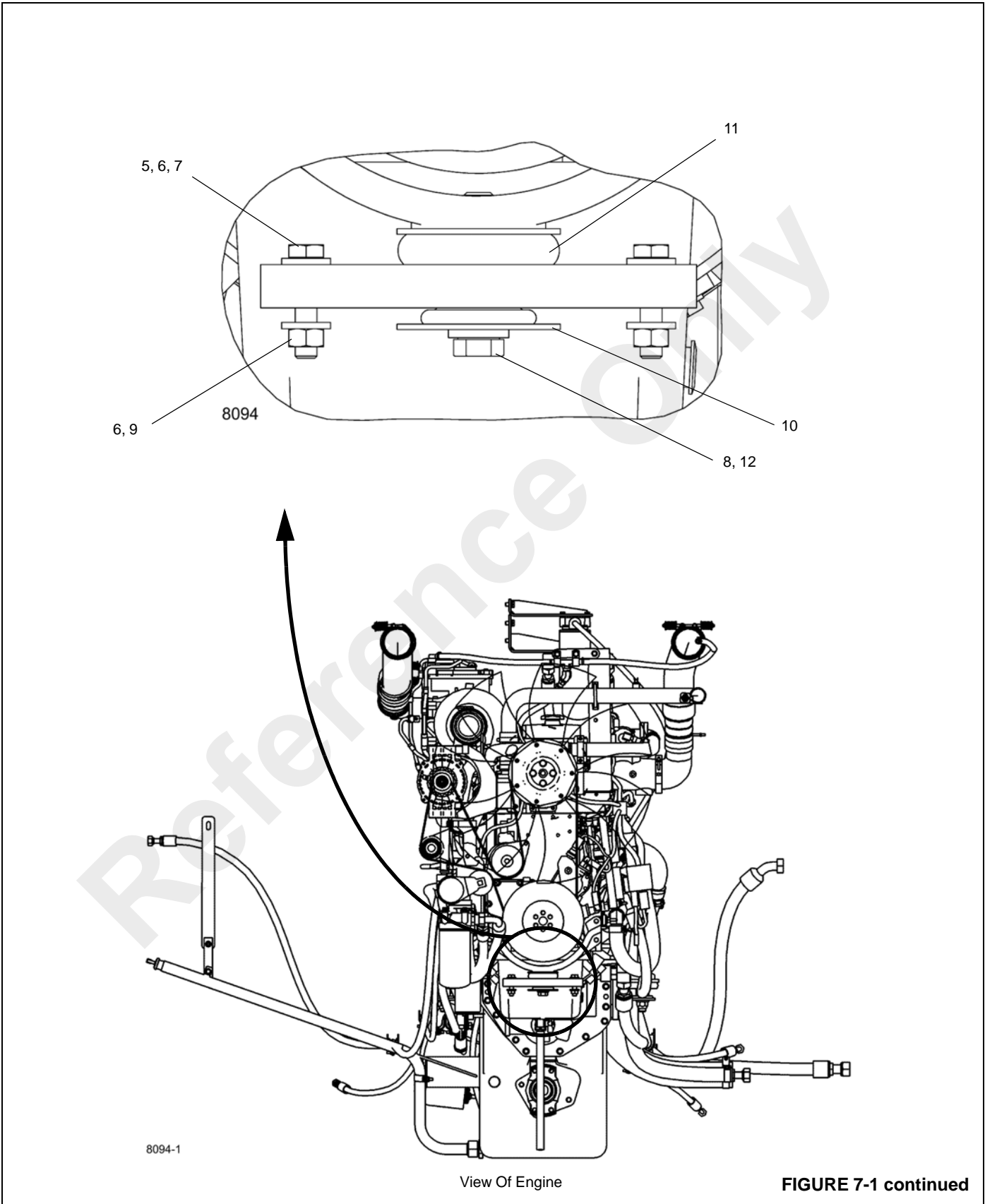

Figure 7-1 Item Numbers

Item	Description
1	Capscrew
2	Washer
3	Dockwasher
4	Locknut
5	Capscrew
6	Washer
7	Mounting Plate
8	Washer
9	Hex Nut
10	Dockwasher
11	Isolator
12	Capscrew

Engine Installation



DANGER

The lifting device must be able to support the combined weight of the engine and transmission.

NOTE: Use the same grade hardware, torque values, and Loctite that were used by the factory.

NOTE: Apply medium strength sealant (Loctite 243) to engine attaching hardware.

- With all components and fittings installed on the new engine, lift the engine into the crane.
- With the engine in position, install the mounting plate, insulator, nuts, washers and capscrews and secure rear of engine (Figure 7-1). Torque M16 grade 10.9 capscrews see Fasteners and Torque Values (pg 1-11).
- At the front of the engine install the capscrews, washers and locknuts and secure the engine to the frame. Torque the M12 grade 8.8 bolts see Fasteners and Torque Values (pg 1-11).
- Remove the lifting device.
- Connect all lines and tubing to the engine, torque converter, and all other components in accordance with the identification marks made during removal.

CAUTION

Do not apply sealant to the inside of the hydraulic suction hoses.

- Install the radiator. Refer to RADIATOR - Installation in this Section. Connect all hoses and electrical harnesses to the radiator as tagged during removal.
- Connect the drive shafts between the transmission/torque converter and the axles. Refer to DRIVE LINES in this Section.
- Install the hood assembly. Install the pump cover.
- Position the start and grid heater relay panel on the right side on the frame and secure with the hardware. If equipped with a remote crank option, reconnect to the engine harness. Connect the battery cables and engine electrical harness connector in accordance with the identification marks made during removal.
- Connect the air filter tubing at the engine and the air filter. Connect the exhaust tubing to the engine and muffler.
- Charge the A/C system.
- Install the hood top door assembly.
- Service the transmission, engine lubrication system, and engine cooling system. See LUBRICATION, page 9-1.
- Start the engine. Check all hoses and fittings for leaks. Recheck all fluid levels.

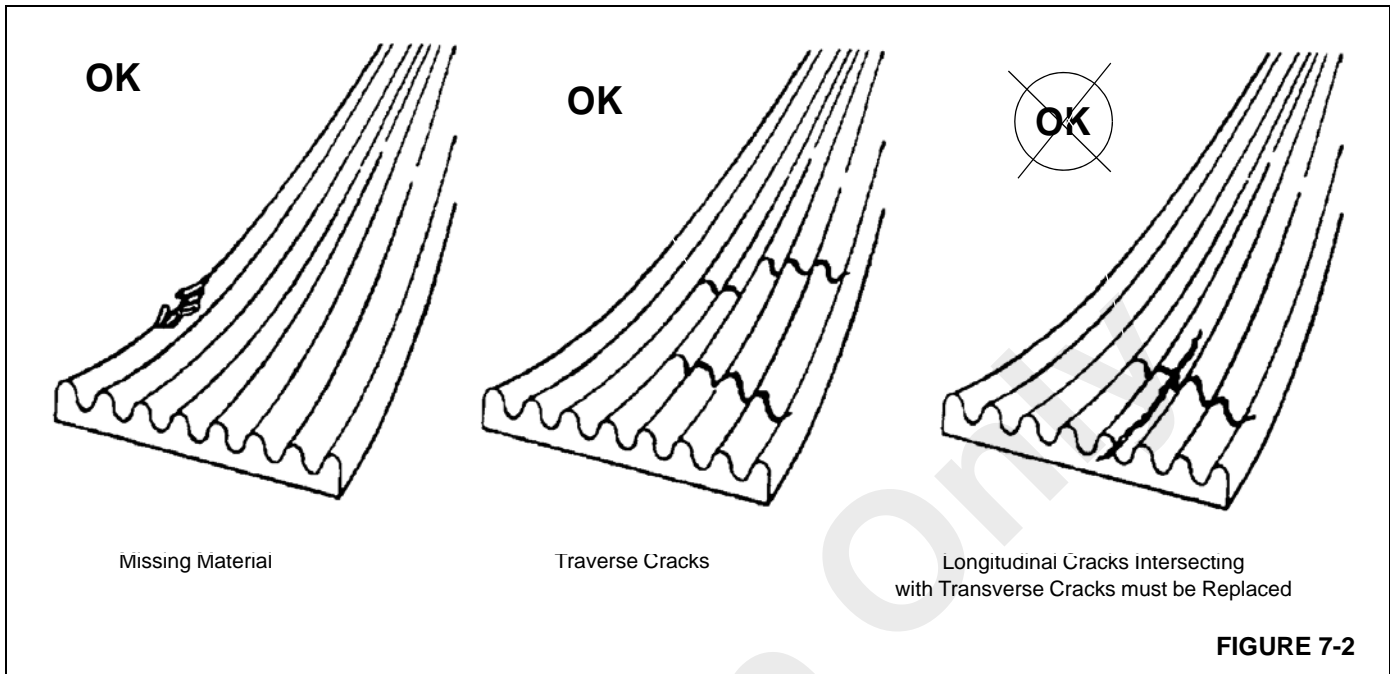

Engine Drive Belts

The proper operation of engine belt-driven components such as the alternator, fan, and water pump depend on the proper condition and tension of the engine drive belt.

NOTE: Belt tension is maintained with an automatic belt tension device.

The engine drive belt should be inspected visually on a daily basis. The drive belt should be inspected for cracks, frayed

areas, and glazed or shiny surfaces (Figure 7-2). A drive belt that is glazed or shiny indicates belt slippage.

Engine drive belt damage can be caused by various factors such as incorrect tension, incorrect belt size, misaligned engine pulleys, incorrectly installed belt, or by oil, grease, or hydraulic fluid on the belt.

Refer to the engine manufacturer's manual for any special tools or belt tension specifications.

FUEL SYSTEM

Description

The fuel system consists of the fuel tank, strainer, lift pump, injection fuel pump, fuel-water separator filter and the fuel injectors. All components except the fuel tank are installed on the engine or supplied with the engine for remote mounting.

Fuel Tank

The fuel tank (Figure 7-3) is a steel cylinder-type tank located on the left side of the machine. The fuel tank has a draw capacity of 220 l (58 gal). A connection on the bottom of the tank provides for fuel supply to the engine. Surplus fuel from the engine is provided to the bottom of the fuel tank below the fuel level. The tank is equipped with a non-vented filler cap, chain-attached to the tank, and a fuel quantity sender unit which provides a signal to a fuel quantity gauge on the instrument panel in the cab.

Injection Fuel Pump

The fuel oil is finely atomized as it is injected into the cylinder and ignited by the heat of the compression. It is metered also, before injection, to meet the load requirements imposed upon the engine. Surplus fuel, returning from the injectors, is bypassed back to the fuel tank or to the inlet side of the pump. The continuous flow of fuel through the injectors helps to cool the injectors and to purge air from the system.

Fuel Filter-Water Separator

The fuel filter-water separator removes impurities from the fuel and also removes water from the fuel before it reaches the engine. The filter is mounted on the left side of the machine

The fuel mixture passes through the outer wrap of the first stage of the filter paper, where large droplets of water are formed as it is stripped from the fuel. The water falls out into the void between the two paper elements and goes to a reservoir in the bottom of the housing, where it can be drained through a drain plug at the bottom of the housing.

Electric Lift Pump

The ECM controls the electric lift pump located between the fuel tank and the injection pump. Whenever the keyswitch is turned to the ON position, the lift pump will be energized for a few seconds to make sure the low pressure fuel lines are fully primed. The electric lift pump shuts off after the engine is started.

Maintenance

NOTE: The entire fuel system must be maintained air tight to prevent loss of prime.

Fuel Tank

The fuel tank should be kept filled, especially overnight, to reduce condensation to a minimum. Refer to the applicable engine manual for the recommended schedule for draining any water or sediment from the tank.

Removal

1. Position a suitable container under the fuel tank and drain all fuel from the tank.
2. Tag and disconnect the lines from the bottom of the tank.
3. Disconnect the electrical lead from the fuel quantity sender unit.
4. Support the weight of the tank, loosen and remove the hardware securing the straps to the mounting brackets. Remove the tank and steps.
5. If a new tank is to be installed, remove the fittings, the fuel quantity sender, and steps from the tank and install them in the new tank.

Installation

1. Position the new tank on the mounting brackets and install the hardware on the two straps. Torque the capscrews, see Fasteners and Torque Values (pg 1-11).
2. Connect the electrical lead to the fuel quantity sender unit.
3. Connect the two lines to the fittings on the bottom of the tank in accordance with the identification marks made during removal.
4. Service the tank.

Fuel Filter-Water Separator

Draining

The sump of the fuel filter-water separator should be drained daily, 30 minutes after the engine is shut down, to remove any water and sediment. Adhere to the following procedure.

1. Open the drain plug.
2. Drain until fuel appears.
3. Close the drain plug.

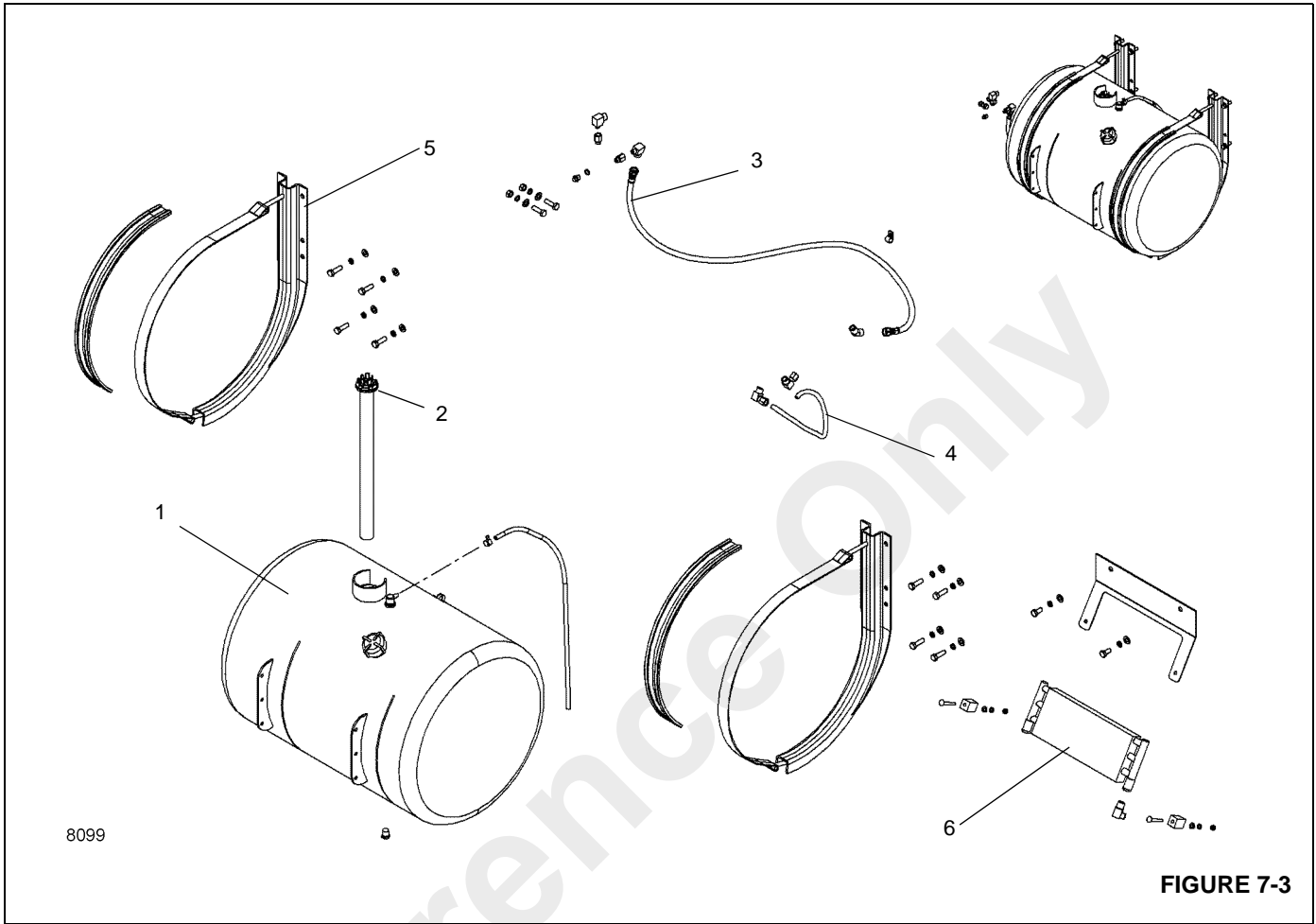

Item	Description
1	Fuel Tank
2	Fuel Level Sensor
3	Fuel Supply
4	Fuel Return
5	Mounting Bracket
6	Fuel Cooler

AIR INTAKE AND EXHAUST SYSTEM

Description

The air intake system (Figure 7-4) controls the quality and amount of air available for combustion. System components are the Air Cleaner, Turbocharger, Charge Air Cooler, Cylinder Head, and Exhaust Manifold. Inlet air is pulled through the Air Cleaner, compressed and heated in the compressor side of the Turbocharger. The air is pushed through the Charge Air Cooler to the Air Inlet Manifold. Cooling the inlet air increases combustion efficiency, lowers fuel consumption, and increases the horsepower. The air is forced into the cylinder head to fill the inlet ports. Air flow from the inlet port into the cylinder is controlled by the intake valves.

Each cylinder has two intake valves and two exhaust valves. When the intake valves open, cooled compressed air from the inlet port is pulled into the cylinder. The intake valves close and the piston begins to move up on the compression stroke. Fuel is injected into the cylinder and combustion starts. The piston is forced down and is on the exhaust stroke when it moves up again. The exhaust valves open and exhaust is expelled through the exhaust port into the exhaust manifold.

The exhaust gas from the exhaust manifold enters the turbine side of the turbocharger and causes the turbine to turn driving the compressor. Exhaust from the turbocharger passes through the exhaust pipe and muffler into the atmosphere.

The Air Cleaner is the dry-type with a replaceable element and is located on the left rear fender. A service indicator, designed to indicate red when servicing is required, is attached to the Air Cleaner.

On the Cummins QSB Engine there are electric air heating elements that are located in the engine's intake air stream. These elements heat the intake air when starting the engine in cold ambient conditions. Startability and white smoke control are enhanced by the use of the intake air heater. A Wait-to-Start Lamp is located on the center front console to indicate when to crank the engine.

Air Intake

Air Cleaner Checks

Dust passing the air cleaner can cause rapid engine wear. All connections between the air cleaner and the engine must be tight and sealed. If these connections are well sealed, and there is still evidence of dust leakage, check the following places for possible trouble.

NOTE: Dust that gets by the air cleaner system can often be detected by looking for dust streaks on the air transfer tubing or just inside the intake manifold inlet.

1. Inspect the air cleaner outlet tube for damage.
2. Ensure the element gasket washer is not damaged and the washer's rubber face seals against the element.
3. Inspect the element gasket for damage.
4. Check for structural failures and replace damaged parts.
5. Inspect the restriction indicator tap for leaks.

Check For Filter Restriction

As a dry cleaner element becomes loaded with dust, the vacuum on the engine side of the air cleaner (at the air cleaner outlet) increases.

The vacuum is generally measured as restriction in kilopascals or inches of water. The engine manufacturer places a recommended limit on the amount of restriction the engine will stand without loss in performance before the element must be cleaned or replaced. Cummins allows a vacuum of 6.2 kPa (25 inches of water) maximum with a dirty air cleaner at maximum governed RPM.

A service indicator attached to the air cleaner housing will indicate when the filter needs to be replaced. Reset the indicator each time the air cleaner is serviced. If the indicator's accuracy is suspect, a water manometer is the most accurate and dependable method of measuring vacuum.

To use the manometer, hold it vertically and fill both legs approximately half full with water. One of the upper ends is connected to the restriction tap on the outlet side of the air cleaner by means of a flexible hose. The other end is left open to the atmosphere.

Maximum restriction in the air cleaner occurs at maximum air flow. On this turbocharged diesel engine, the maximum air flow occurs only at maximum engine power.

With the manometer held vertically and the engine drawing maximum air, the difference in the height of the water columns in the two legs, measured in inches or centimeters, is the air cleaner restriction. Restriction indicators are generally marked with the restriction at which the red signal flag locks up.

If the initial restriction on a new or clean filter reads above the maximum allowed for the engine, check the following items:

1. Ensure the air cleaner inlet is not plugged.
2. Inspect the air cleaner outlet to be sure it is not plugged by paper, rags, etc.
3. Ensure the correct size connections are used between the air cleaner and the engine.
4. Ensure all inlet accessories are the correct size and are not plugged by any foreign object.

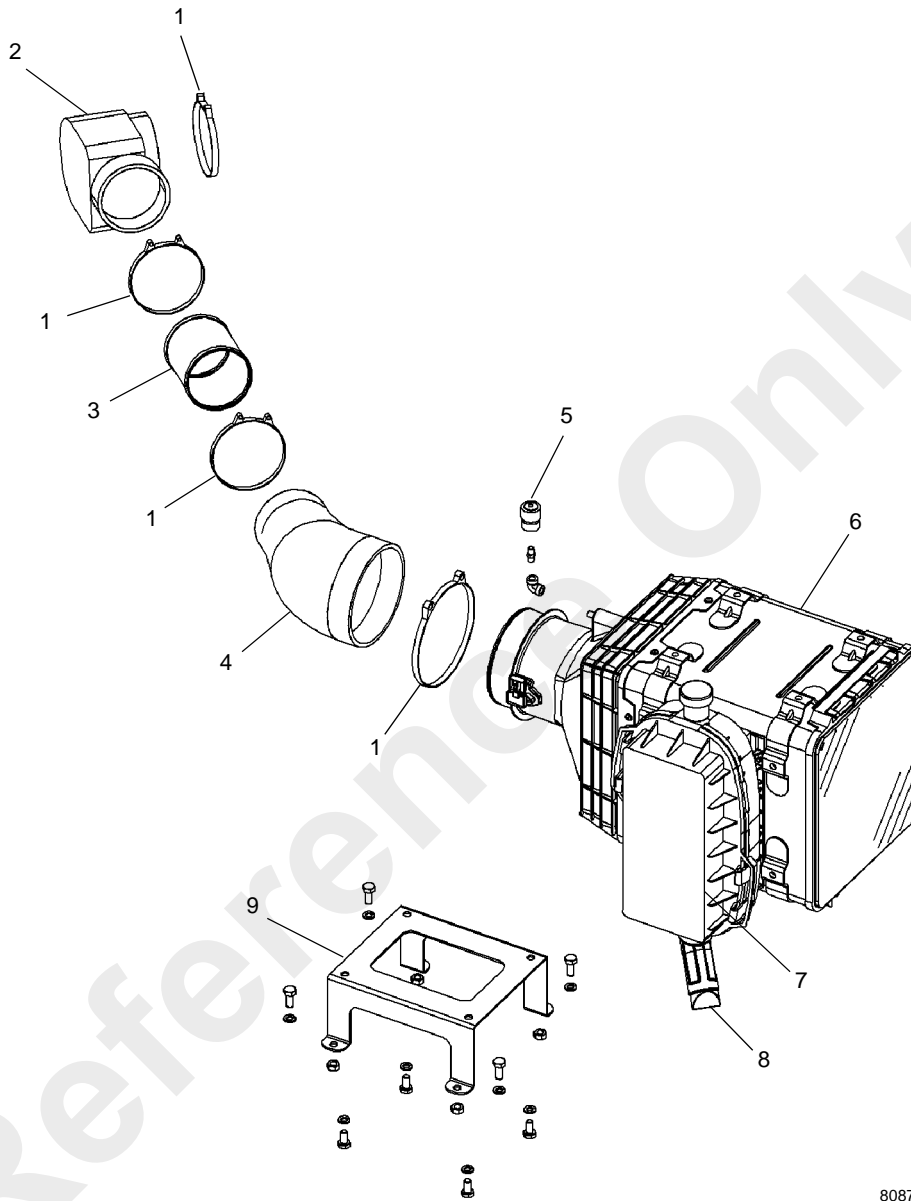

Air Intake Installation - Typical

FIGURE 7-4

Figure 7-4 Item Numbers

Item	Description
1	T-bolt Clamp
2	Elbow
3	Air Intake Tube
4	Elbow
5	Service Indicator
6	Air Cleaner Assembly
7	Precleaner
8	Vacuator Valve
9	Air Cleaner Mounting Bracket

Filter Element Replacement

CAUTION

Never service the air cleaner while the engine is running.

1. Lift the clips (1) (Figure 7-5) securing the cover to the air cleaner body and remove the cover.

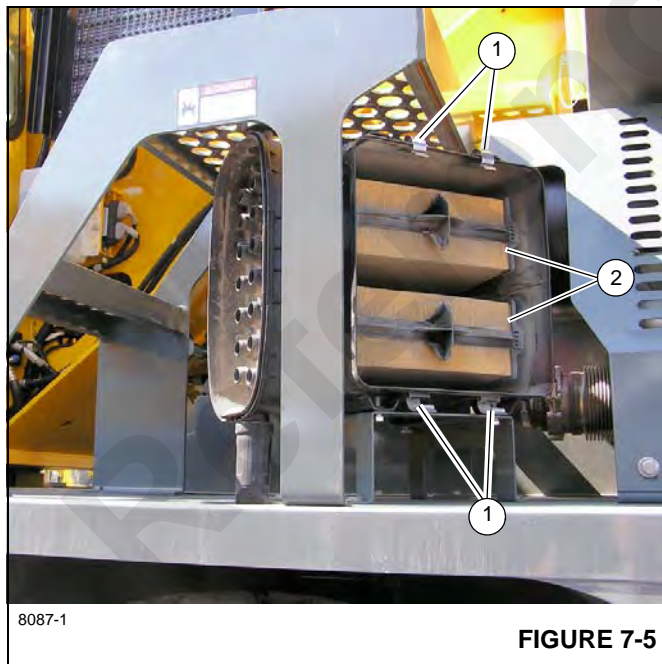

FIGURE 7-5

2. Remove primary filter (2) (Figure 7-5) from the air cleaner and inspect for foreign material and marks of dust.
3. Remove secondary filter (not shown) from the air cleaner every third primary filter change.
4. Thoroughly clean the sealing surface and inside of the air filter housing. Inspect all parts of the intake system and air cleaner.

5. Install new secondary filter (if necessary) and new primary filter.
6. Place the cover back on the air cleaner housing and secure with clips (1).
7. Check all connections and ducts for an air tight fit. Make sure that all clamps, bolts, and connections are tight. Check for holes in piping. Leaks in the air intake system may send dust directly to the engine.
8. Replace decking access plate.

Element Cleaning

It is not recommended that filter elements be cleaned. Cummins and most other manufacturers will not warrant a cleaned air filter.

Air Cleaner Body

Before installing the filter element, remove foreign material (leaves, lint or other foreign matter) that may have collected inside the air cleaner body. Inspect the inside of the body for dents or other damage that would interfere with air flow or with the fins on the element or inside the body. Repair any body dents, being careful not to damage the sealing surfaces. Be sure to clean the sealing surface of the outlet tube and the inside of the outlet tube, taking care not to damage the sealing area on the tube.

Precleaner

The precleaner (1) (Figure 7-6) prevents large debris from entering the air cleaner and should be cleaned periodically, especially when working in severe dust conditions. Remove the top half of the precleaner by releasing the two latches on the sides of the precleaner. Remove all debris from inside precleaner and reassemble.

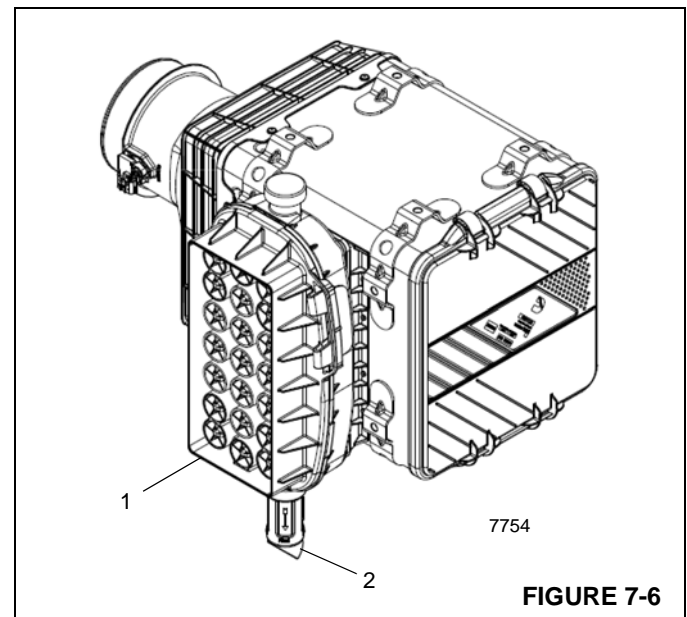

FIGURE 7-6

Vacuator Valve

Vacuator valves (2, Figure 7-6) (Figure 7-7) are designed to expel loose dust and dirt from the air cleaner body automatically, thus lengthening the element service life. The valve lips must point straight down and be kept free from debris to operate effectively. Mud and chaff can lodge in these lips periodically and hold them open during engine operation.

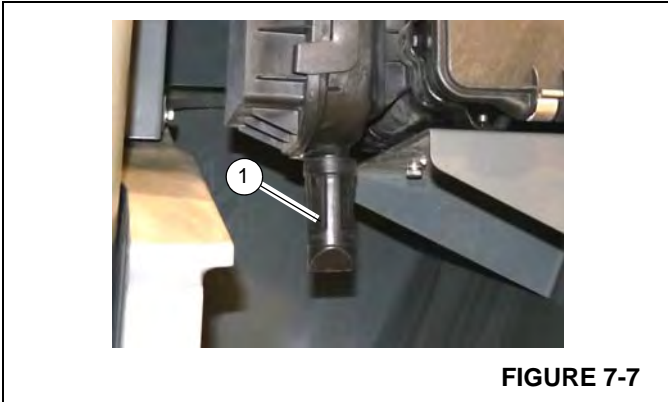

FIGURE 7-7

Check the condition of the valve and lips frequently and keep them clean. The valve lips should be open only when the engine is shut down, or running at low idle speed. If the valve is turned outside in, check for a clogged air cleaner inlet. Malfunction of this valve does not reduce the air cleaner effectiveness, but does allow the element to get dirty faster and reduces serviceable life. If a valve is lost or damaged, replace it with a new valve of the same part number.

Duct Work

1. Check the intake pipe cap and screen for accumulation of leaves, trash, and other debris that could restrict air flow. Repair the screen or replace the cap if any large holes are found in the screen.
2. Check all mounting hardware for security to eliminate possible vibration of intake piping. Such vibration leads to early failure of hoses, clamps, and mounting parts, and can cause hoses to slip off the connecting pipes, allowing un-filtered air into the engine air intake.
3. Check hoses for cracks, chafing, or deterioration, and replace at the first sign of probable failure.

Charge-Air Cooler System

The charge-air cooler (CAC) (Figure 7-8) is used to cool engine air after it has passed through a turbocharger, but before it enters the engine. The charge-air cooler provides better horsepower, increased fuel efficiency, and reduces engine emissions.

The CAC system consists of the ducting to and from the charge-air cooler and a hydraulically driven fan. The charge-air cooler system must be air-tight in order to work efficiently.

The ducting consists of metal tubing, hose clamps and bellows. The recommended installation torque of the spring

loaded T-bolt clamps is 11.3 Nm (100 lb-in). Do not compress the spring completely, the bellows and/or clamp may be damaged from thermal expansion of the CAC tube.

Maintenance

Check the hose clamps for proper torque.

Inspect the bellows for cracks or holes.

Clean the charge-air cooler, removing any dirt or debris.

Verify the fan is operating correctly and there are no hydraulic leaks.

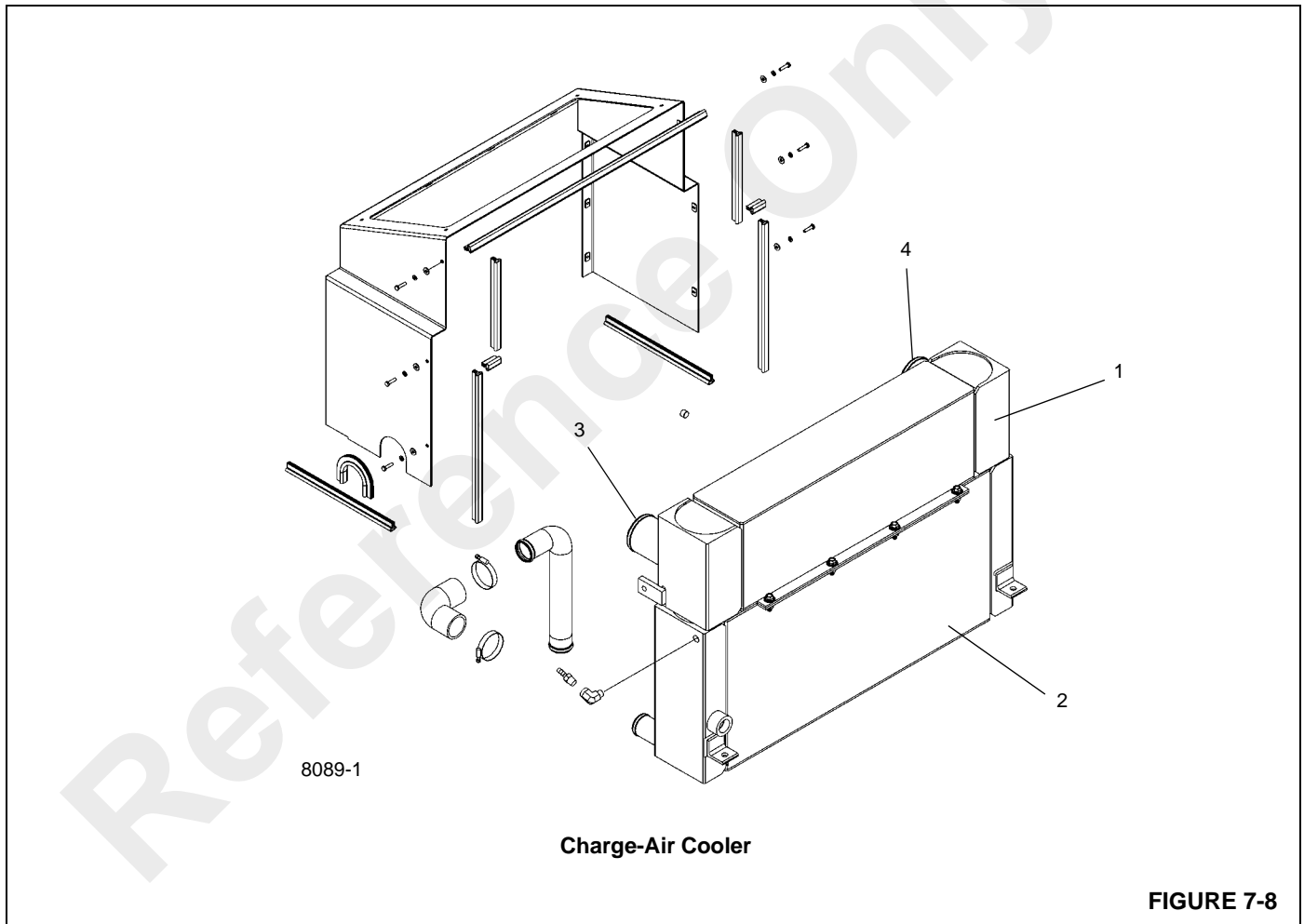

Item	Description
1	CAC
2	Engine Coolant Radiator
3	CAC Hot Air Inlet
4	CAC Cold Air Outlet

Muffler and Diesel Oxidation Catalyst - Tier 4 Interim

Removal



CAUTION

Burn Hazard!

Do not touch muffler or exhaust parts until they are at ambient temperature. Severe burning may result.

1. Remove the sheet metal guard to gain access to the muffler and diesel oxidation catalyst.
2. Remove clamp to free exhaust tailpipe from muffler.
3. Remove clamps to free elbow from muffler.
4. Loosen mounting bands and remove muffler.
5. Remove clamp to free exhaust tube.
6. Remove clamp to free tube exhaust weldment/bellows assembly and remove.
7. Loosen mounting band to free diesel oxidation catalyst and remove diesel oxidation catalyst.
8. Inspect muffler, diesel oxidation catalyst, exhaust tailpipe, exhaust tubes, bellows, and attaching hardware. Repair or replace any of these parts if damaged or missing.

Installation

When assembling the muffler/diesel oxidation catalyst leave the clamps and mounting hardware loose until the assembly is together.

1. Install the diesel oxidation catalyst into the mounting band.
2. Connect the tube exhaust weldment/bellows assembly.
3. Install the muffler into the mounting bands.
4. Attach the elbow to the muffler using the clamp.
5. Install the exhaust tailpipe on the muffler. Secure the exhaust tailpipe to the muffler with clamp. Adjust the clamp as needed.
6. Tighten all hardware and clamps.
7. Install sheet metal guard.

Slip Joint Exhaust Connectors

Slip joint exhaust couplers require tightening to avoid exhaust leaks. Perform the following procedures at the appropriate intervals.

After 1000 Hours, or One Year

Visually inspect the exhaust connector. If necessary, tighten the v-clamps by one full turn of the nuts.

2000 Hours or 2 Years

Tighten the v-clamps by 1 ½ turns of the nuts.

4000 Hours or 4 Years

Tighten the v-clamp by 1 ½ turns of the nuts.

5000 Hours or 5 Years

Remove the v-clamps and gaskets, and replace them with new gaskets and clamps. Tighten the v-clamps to 9.6 to 11.3 Nm (85 to 100 lb-in) of torque.

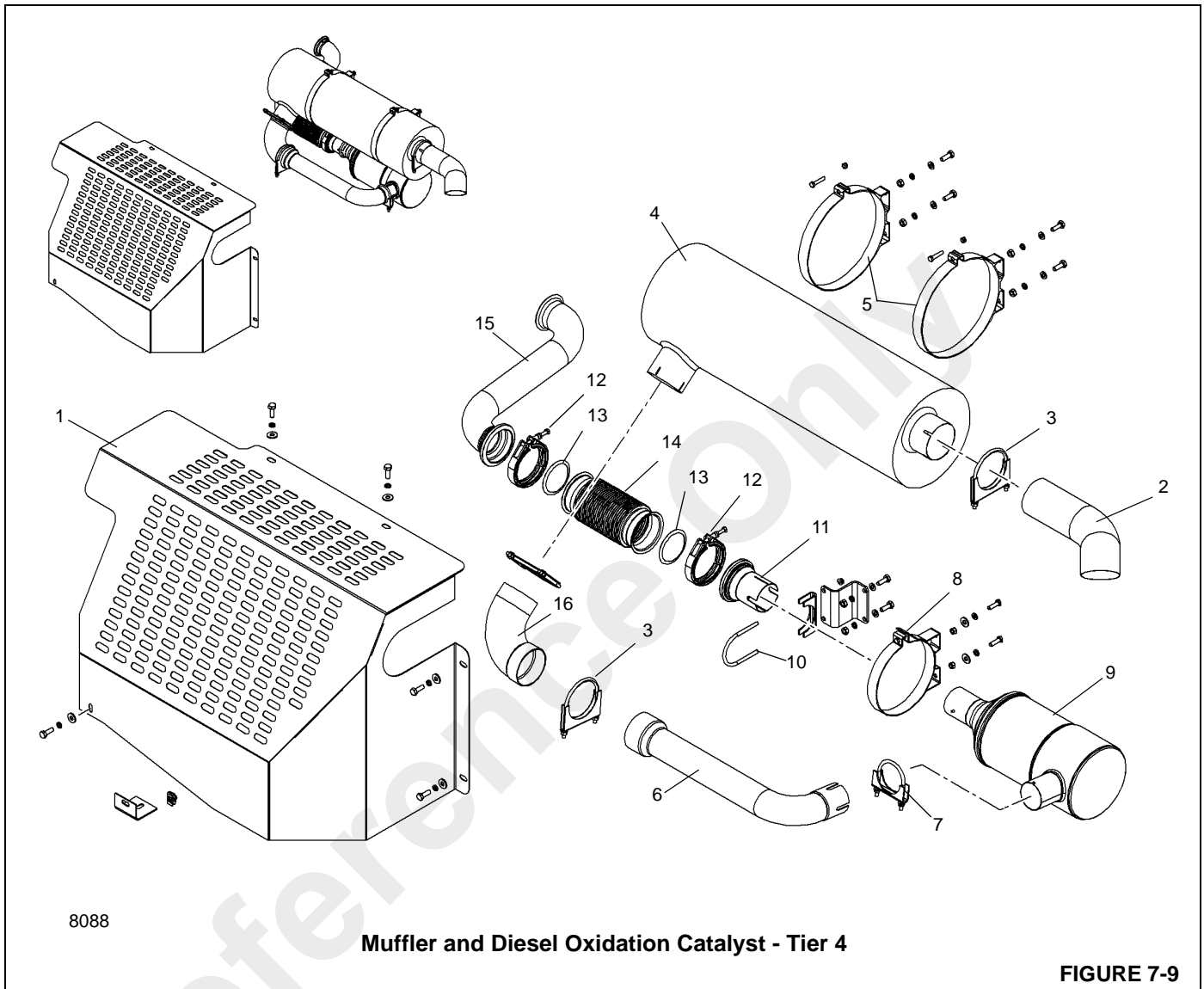

Muffler and Diesel Oxidation Catalyst - Tier 4

FIGURE 7-9

Item	Description
1	Sheet Metal Guard
2	Tail Pipe
3	Muffler Clamp
4	Muffler
5	Mounting Band
6	Exhaust Tube
7	Muffler Clamp
8	Mounting Band

Item	Description
9	Diesel Oxidation Catalyst
10	Muffler Clamp
11	Tube Exhaust Weldment
12	Clamp
13	Gasket
14	Bellows
15	Tube Exhaust Weldment
16	Elbow

WATER COOLING SYSTEM

Description

The cooling system consists of a radiator (Figure 7-10), surge tank, engine cooling circuit, charge air cooler circuit, the connecting hoses and connecting tubes. Cooling system capacity is approximately 28.4 l (30 qt). The radiator consists of two sections; the top section is the charge air cooler and the bottom section is the engine water cooler. The temperature is controlled by a 83°C (181°F) thermostat located between the top of the engine and the top of the radiator. At all times, the antifreeze/coolant should be properly inhibited against corrosion. It is recommended that a mixture of AFC-50/50 blended ethylene-glycol, low silicate, fully formulated, engine antifreeze/coolant concentrate and water which does not require a pre-charge of supplemental coolant additives (SCA) for use in initial fill of heavy duty liquid cooled internal combustion engines be used at all times.

The crane is equipped with a cab hot water heater. Hot water is supplied by the engine coolant system through a strainer and two port water swivel to the cab heater. The strainer is a cleanable type and is located on the left side of the transmission by the rear engine/transmission mount. Refer to Section 9 - LUBRICATION for service of the strainer.

Maintenance

General

The cooling system includes the Radiator, Surge Tank, Thermostat, the Fan, and Water Pump. Radiator hoses are also included in this group.

The cooling system is often neglected because the effects or damage that result from an improperly maintained system usually occur gradually. The cooling system needs to be maintained with the same attention as other systems.

The circulation of water through the cooling system relies entirely upon the water pump. The water pump draws water from the radiator and forces it through the water jacket and cylinder head. There it accumulates heat and flows to the radiator tank. Then the water flows across through the radiator core and is cooled by air from the fan. This process of removing heat from water as it circulates holds the engine to its efficient operating temperature.

The following paragraphs point out several facts about cooling system components, the effects of cooling system neglect, and procedures to be followed for cooling system maintenance.

Effects of Cooling System Neglect

Whenever an engine does not perform at top efficiency, a neglected cooling system may be at fault even though the

part directly responsible is not a part of the cooling system. Most of these problems can be traced to overheating; however, an engine that is running too cold can be just as troublesome.

Overheating

An engine that is overheating may lead to troubles such as the following:

1. Burned valves.
2. Pinging or knocking.
3. Excessive fuel consumption.
4. Poor lubrication - increased engine wear.
5. Sticking valves.
6. Short injector life.
7. Engine hot spots.
8. Need for higher grade fuel.

Overcooling

The following engine troubles result when an engine is overcooled:

1. Excessive fuel consumption.
2. Sludge formation in crankcase.
3. Corrosive acids formed in crankcase.
4. Excessive fuel deposits in the exhaust system.

Antifreeze/Coolant

Heavy duty diesel engines require a balanced mixture of water and antifreeze/coolant. For maximum rust, freeze, and boiling point protection, a 50/50 blended, fully formulated extended life antifreeze/coolant should be maintained at all times. Refer to *LUBRICATION*, page 9-1. Do not use more than 50 percent antifreeze/coolant in the mixture unless additional freeze protection is required. Never use more than 68 percent antifreeze/coolant under any condition. Antifreeze/coolant at 68 percent provides the maximum freeze protection; antifreeze/coolant protection decreases above 68 percent.

Rust Prevention

To keep engines operating at like new efficiency, all forms of rust formation must be prevented. The formation of rust in the cooling system is a result of the interaction of water, iron, and oxygen, and can only be prevented by maintaining full strength corrosion protection at all times. Supplemental coolant additives (SCA) are recommended for this cooling system. Antifreeze/coolant alone does not provide sufficient protection for heavy-duty diesel engines. Refer to *Section 9* for SCA specification and compatible brands.

Engine Antifreeze/Coolant Fill Procedure (when level is low)

1. Fill the system with a 50/50 blended, fully formulated extended life antifreeze/coolant. Fill to the bottom of the surge tank filler neck. Fill slowly. Flow exceeding 11.2 l/min (3 gpm) can give a false reading.
2. Wait one minute and recheck the antifreeze/coolant level. Refill as necessary repeating step 1.
3. Run the engine for 5 minutes and recheck the antifreeze/coolant level. Refill as necessary repeating step 1. Refer to *LUBRICATION*, page 9-1.

Antifreeze/Supplemental Coolant Additives Maintenance Summary

Cooling System Level Check Interval

Daily or 10 hours

The cooling system level should be checked every 10 hours of operation or daily, whichever comes first. Refer to *LUBRICATION*, page 9-1.

SCA Level Check/Coolant Filter Change Interval

6 months or 500 hours

- Check SCA Levels (use only Coolant Test Kit, Grove P/N 9414101675, to check the coolant additive concentration in the cooling system)
- Only add coolant additive if levels are less than 1.2 units/gal (see *LUBRICATION*, page 9-1 for specification and recommended additives).

NOTE: An inadequate concentration of coolant additive can result in major corrosive damage to the cooling system components. Over concentration can cause formation of a "gel" that can cause restriction or plugging of coolant passages, and overheating.

1 year or 1000 hours

- Test antifreeze/coolant for contamination.
Condemning limits are:
 - Sulfate level greater than or equal to 1500 ppm.
 - Chloride level greater than or equal to 200 ppm.
 - The pH level is less than 6.5.
 - Oil or fuel contamination can be identified by odor or color.

If condemned, flush the system using a commercially available flushing agent. Refill system with fully

formulated extended life coolant. Refer to *LUBRICATION*, page 9-1.

NOTE: Remove the radiator cap when draining the system to ensure proper draining.

Cleaning



CAUTION

Burn Hazard!

The cooling system contains very hot pressurized liquid and injury can result when removing the radiator cap at operating temperature. Use proper protection to remove the radiator cap.

1. Coolant shut-off valves to heaters and other accessories should be open to allow complete circulation during cleaning, flushing, and draining. Run the engine with radiator covered if necessary until temperature is up to operating range 71 to 82° C (160 to 180° F). Stop the engine, remove the radiator cap, and drain the system by opening the drain cocks on the radiator and engine block.

NOTE: Use a cleaning compound that is not corrosive to aluminum to prevent damage to the radiator.

2. Allow the engine to cool, close the drain cocks, and pour the cleaning compound into the surge tank according to the directions. Fill the system with water.
3. Place a clean drain pan to catch the overflow, and use it to maintain the level in the radiator. Do not spill the solution on the vehicle paint.
4. Replace the radiator cap and run the engine at moderate speed, covering the radiator if necessary, so the system reaches a temperature of 82° C (180° F) or above, but does not reach the boiling point. Allow the engine to run at least two hours, or according to recommendations of the manufacturer of the cleaning compound, at 82° C (180° F) so the cleaning solution may take effect. Do not drive the vehicle or allow the liquid level in the radiator to drop low enough to reduce circulation.
5. Stop the engine as often as necessary to prevent boiling.
6. With the engine stopped, feel the radiator core with bare hands to check for cold spots, and then observe the temperature gauge reading. When there is no change in temperature for some time, drain the cleaning solution.
7. If clogging of the core is relieved but not fully corrected, allow the engine to cool, pressure-flush the system (see *Pressure Flushing*) and repeat the cleaning operation.
8. If problem persists, replace radiator.

Pressure Flushing

1. Disconnect both radiator hoses that connect the radiator to the engine.
2. Clamp a convenient length of hose to the radiator core outlet opening, and attach another suitable length of hose to the radiator inlet opening to carry away the flushing stream.
3. Connect the flushing gun to compressed air and water pressure, and clamp the gun nozzle to the hose attached to the radiator outlet opening.
4. Fill the core with water. Turn on air pressure in short blasts to prevent core damage.
5. Continue filling the radiator with water and applying air pressure as above until the water comes out clear.
6. Clamp the flushing gun nozzle firmly to a hose attached securely to the engine water outlet opening. Fill the engine block with water, partly covering the water inlet opening to permit complete filling.
7. Turn on compressed air to blow out water and loose sediment. Continue filling with water and blowing out with air until flushing stream comes out clear.
8. When the vehicle is equipped with a water heater connected to the cooling system, flush the heater, following the same procedure as for the radiator core.
9. After completing the flushing operation, clean out the surge tank overflow pipe; inspect the water pump; clean the thermostat and the radiator cap control valves. Check the thermostat for proper operation before installation.
10. Blow insects and dirt from the radiator core air passages, using water, if necessary, to soften obstructions.

Component Inspection

Radiator/Surge Tank

1. Side Tanks - Look for leaks, particularly where the tank is attached to the core. Vibration and pulsation from pressure can fatigue soldered seams.
2. Filler Neck - The sealing seat must be smooth and clean. Cams on filler neck must not be bent or worn so as to allow a loose fitting cap. Ensure the overflow tube is not plugged.
3. Radiator Cap - This is the pressure-setting type. Its purpose is to hold the cooling system under a slight pressure, increasing the boiling point of the cooling solution and preventing loss of solution due to evaporation and overflow.

The cap has a spring-loaded valve, the seat of which is below the overflow pipe in the filler neck. This prevents the escape of air or liquid while the cap is in position. When the cooling system pressure reaches a predetermined point, the cap valve opens and will again close when the pressure falls below the predetermined point.

When removing the pressure type cap, perform the operation in two steps. Loosening the cap to its first notch raises the valve from the gasket and releases the pressure through the overflow pipe. In the first stage position of the cap, it should be possible to depress the cap approximately 3 mm (0.13 in). The prongs on the cap can be bent to adjust this condition. Care must be taken that the cap is not too loose as this would prevent proper sealing.



CAUTION

Burn Hazard!

Loosen cap slowly and pause a moment to avoid possible burning by hot water or steam. Continue to turn the cap to the left until it can be removed.

4. Tubes are very small and can easily become clogged by rust and scale. The general condition of the cooling system and operating temperature are indications as to whether or not tubes are clean. Another good test is to feel the core for cold spots.
5. Fins are thin metal sheets that dissipate heat picked up by the tubes. They should be kept free of bugs, leaves, straw etc., so as to allow the free passage of air. Bent fins should be straightened.

Engine Water Jacket

The water jacket permits coolant to be circulated around the cylinder walls, combustion chamber, and valve assemblies. Some of these coolant passages are small and can easily become clogged, if the cooling system does not receive the proper maintenance.

1. Core Plugs - These are sometimes mistakenly called freeze plugs. They do not provide protection against freezing expansion, but are only present because of engine block casting methods. Remove and replace core plugs that show signs of leaking or rusting through. Use an installation tool for core plug replacement.
2. Drain Plugs - The water jacket of each engine could have one or more drain plugs. These should receive seasonal care and be kept free of rust and scale.
3. Gaskets - All gaskets must be in good condition to prevent both internal and external leaks. If there are external leaks around gaskets, there may also be internal leaks into the engine. Proper tightening of the

head bolts with a torque wrench is essential for preventing leaks around the head gasket.

Water Pump

The pump should be checked carefully for leaks and proper lubrication. Replace or rebuild if leaking, cracked, or worn.

Fans and Belts

The fan should be checked for cracked or broken blades.

Refer to *Engine Drive Belts*, page 7-6.

Thermostat

The thermostat is of the nonadjustable type and is incorporated in the cooling system for the purpose of retarding or restricting the circulation of coolant during engine warm up. Engine overheating and loss of coolant is sometimes due to an inoperative thermostat. To check for this condition, remove the thermostat and test by submerging it in hot water and noting the temperature at which the thermostat opens and closes. Use an accurate high temperature thermometer for making this test.

Hoses and Clamps

Hoses and their connections must be checked regularly because they are often the source of hidden trouble. Hoses may often times appear in good condition on the outside while the inside will be partially deteriorated. If there are any doubts about a hose doing its job, replacement should be made. The clamps should be inspected to make sure they are strong enough to hold a tight connection.

Test Equipment

The antifreeze/coolant concentration must be checked using a refractometer. "Floating ball" type density testers or hydrometers are not accurate enough for use with heavy duty diesel cooling systems.

Antifreeze/Coolant

Heavy duty diesel engines require a balanced mixture of water and antifreeze/coolant. Fill the system with a AFC-50/50 blended, fully formulated extended life antifreeze/coolant at all times. Refer to Section 9 - LUBRICATION. Do not use more than 50 percent antifreeze/coolant in the mixture unless additional freeze protection is required. Never use more than 68 percent antifreeze/coolant under any condition. Antifreeze/coolant at 68 percent provides the maximum freeze protection; antifreeze/coolant protection decreases above 68 percent.

Radiator Removal and Installation

Removal

1. Set the outriggers and position the boom to over the side.
 2. Open the drain cock at the end of the hose coming from the water pump (under the front of engine) and drain the coolant into a suitable container. Dispose of in accordance with local and EPA regulations.
 3. Tag and disconnect all hoses from the top and bottom sections of the radiator assembly.
 4. Remove the hardware attaching the fan guard to the shroud. The fan guard will remain with the engine.
 5. Remove the hardware securing the support plate on each side of the radiator.
- NOTE:** The radiator assembly weighs approximately 44.4 kg (97.9 lb).
6. Attach an adequate lifting device to the radiator assembly.
 7. Remove the hardware securing the radiator to the mount bracket and remove the radiator assembly from the carrier.

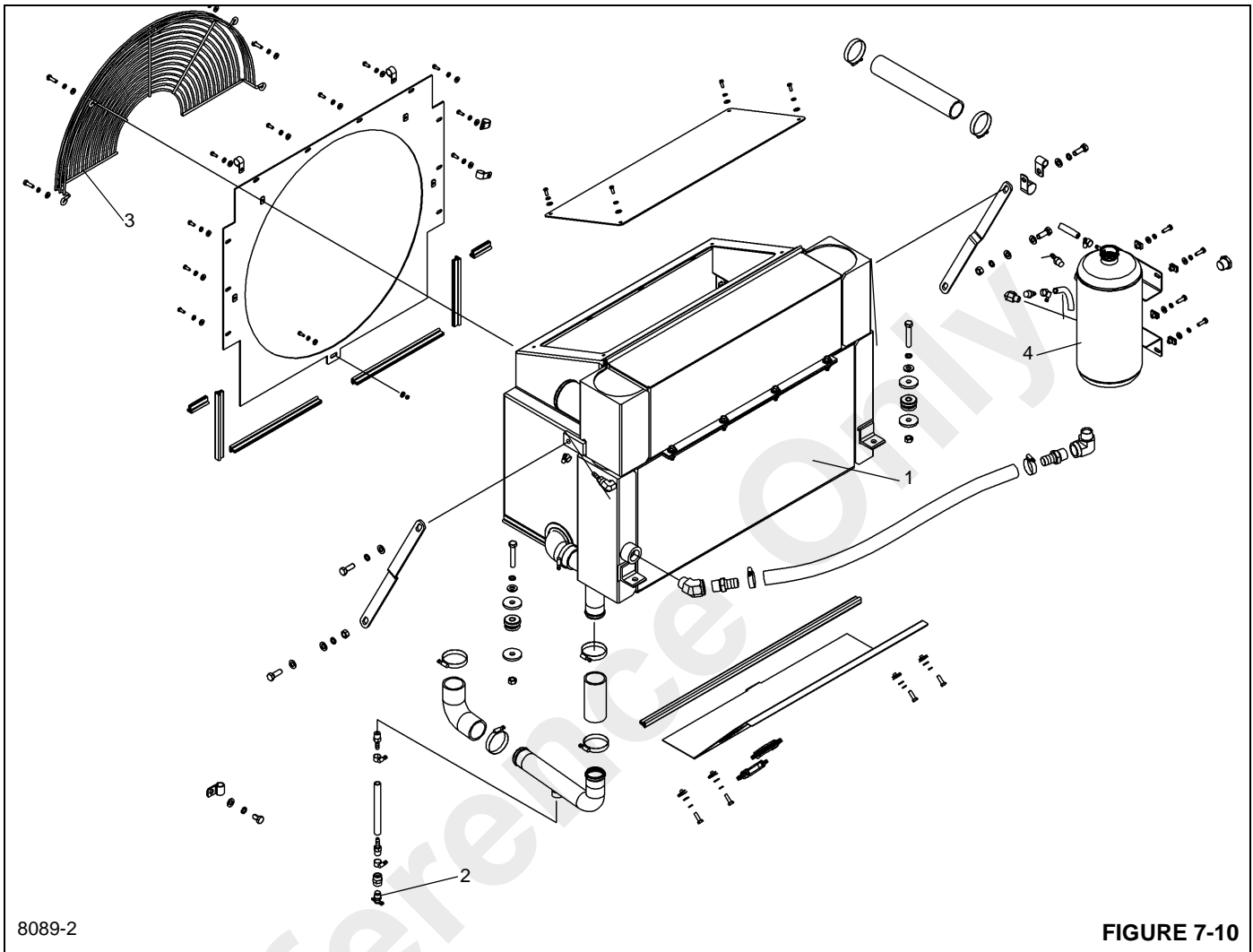

8089-2

FIGURE 7-10

Item	Description
1	Radiator Assembly
2	Drain Cock
3	Fan Guard
4	Overflow Tank

Installation

1. Position the radiator assembly in the carrier using a lifting device and secure the radiator to the mount bracket with the hardware.
2. Secure the support plates to each side of the radiator using a bolt.
3. Attach the fan guard to the shroud using the hardware.
4. Connect all hoses to the radiator assembly as tagged during removal.
5. Ensure the drain cock is closed.
6. Service the engine coolant system, transmission oil system, and the hydraulic system as necessary. Start the engine, operate all systems and check for leaks.

DRIVE TRAIN

Description

The drive train consists of the transmission/torque converter assembly and three drive lines.

The transmission/torque converter is mounted to and driven by the engine. The torque converter assembly provides for mounting and driving the pumps. The transmission is a powershift with six forward speeds and six reverse speeds. The transmission is controlled electrically by a shift lever/knob located on the right side of the steering column and an axle drive mode selector rocker switch located on the left side of the front console.

The transmission/torque converter oil is cooled by passing the oil through an externally mounted transmission cooler. The cooler is part of the radiator. An oil filter is located on the left side of the frame bottom rail.

Three drive lines are used. Two drive lines are connected between the transmission and the front axle and the other drive line is connected between the transmission/torque converter and the rear axle.

Maintenance

Drive Lines

CAUTION

Do not disassemble drive lines when removing them from the crane. Dirt can enter the spline and cannot be purged. In addition, the drive lines are assembled in a specific orientation when manufactured and can easily be incorrectly reassembled.

Removal

1. Support the drive line being removed so it does not fall when disconnected.
2. Remove the bolts from the bearing cap on each end of the drive line.
3. Remove the drive line.

Installation

1. Position the drive line, install the bearing cap bolts and tighten bolts securely.
2. Torque the inboard bearing cap bolts on the drive line to 95 to 108 Nm (70 to 80 lb-ft) and outboard bearing caps to 127 to 142 Nm (94 to 105 lb-ft).

Lubrication

The drive line slip joints require lubrication. Refer to Section 9 - Lubrication.

Transmission/Torque Converter

Description

The transmission/torque converter assembly is mounted to the engine and is connected to the front and rear axles by two drive shafts. The main hydraulic pump is mounted on the torque converter housing.

Theory of Operation

The transmission and torque converter function together and operate through a common hydraulic system. Therefore, it is necessary to consider both units in discussing operation.

With the engine running, the converter charging pump draws oil from the transmission sump through the removable oil suction screen and directs it through the pressure regulating valve and oil filter.

The pressure regulating valve maintains pressure to the transmission control for actuating the direction and speed clutches. This requires a small portion of the total volume of oil used in this system. The remaining volume of oil is directed through the torque converter circuit to the oil cooler and returns to the transmission for positive lubrication. This regulator valve consists of a hardened valve spool operating in a closely fitted bore. The valve spool is spring loaded to hold the valve in a closed position. When a specific pressure is achieved, the valve spool works against the spring until a port is exposed along the side of the bore. This sequence of events provides the proper system pressure.

After entering the converter housing, the oil is directed through the reaction member support to the converter blade cavity and exits in the passage between the turbine shaft and reaction member support. The oil then flows out of the converter to the oil cooler. After leaving the cooler, the oil is directed to a fitting on the transmission. Then, through a series of tubes and passages, lubricates the transmission bearings and clutches. The oil then gravity drains to the transmission sump.

The torque converter consists basically of three elements and their related parts to multiply engine torque. The engine power is transmitted from the engine flywheel to the impeller element through the impeller cover. This element is the pump portion of the hydraulic torque converter and is the primary component which starts the oil flowing to the other components which results in torque multiplication. This element can be compared to a centrifugal pump, in that it picks up fluid at its center and discharges at its outer diameter.

The torque converter turbine is mounted opposite the impeller and is connected to the output shaft of the torque converter. This element receives fluid at its outer diameter and discharges at its center. Fluid directed by the impeller out into the particular design of blading in the turbine and

reaction member is the means by which the hydraulic torque converter multiplies torque.

The reaction member of the torque converter is located between and at the center of the inner diameters of the impeller and turbine elements. Its function is to take the fluid which is exhausting from the inner portion of the turbine and change its direction to allow correct entry for recirculation into the impeller element.

The torque converter will multiply engine torque to its designed maximum multiplication ratio when the output shaft is at zero rpm. Therefore, as the output shaft is decreasing in speed, the torque multiplication is increasing.

The shift control valve assembly consists of a valve body with selector valve spools. A detent ball and spring in the selector spool provides one position for each speed range. A detent ball and spring in the direction spool provides three positions, one each for forward, neutral, and reverse.

With the engine running and the directional control lever in the neutral position, oil pressure from the regulating valve is blocked at the control valve, and the transmission is in neutral. Movement of the forward and reverse spool will direct oil, under pressure, to either the forward or reverse direction clutch, as desired. When either directional clutch is selected, the opposite clutch is relieved of pressure and vents back through the direction selector spool. The same procedure is used in the speed selector.

The direction or speed clutch assembly consists of a drum with internal splines and a bore to receive a hydraulically actuated piston. The piston is oil tight by the use of sealing rings. A steel disc with external splines is inserted into the drum and rests against the piston. Next, a friction disc with splines at the inner diameter is inserted. Discs are alternated until the required total is achieved. A heavy back-up plate is then inserted and secured with a snap ring. A hub with OD splines is inserted into the splines of discs with teeth on the inner diameter. The discs and hub are free to increase in speed or rotate in the opposite direction as long as no pressure is present in that specific clutch.

To engage the clutch, the control valve is placed in the desired position. This allows oil under pressure to flow from the control valve, through a tube, to a chosen clutch shaft. This shaft has a drilled passageway for oil under pressure to enter the shaft. Oil pressure sealing rings are located on the clutch shaft. These rings direct oil under pressure to the desired clutch. Pressure of the oil forces the piston and discs against the heavy back-up plate. The discs, with teeth on the outer diameter, clamping against discs with teeth on the inner diameter, enables the hub and clutch shaft to be locked together and allows them to drive as a unit.

There are bleed balls in the clutch piston which allow quick escape for oil when the pressure to the piston is released.

Maintenance

General Information

1. Always check the oil level with the engine idling, and the transmission in neutral and at normal operating temperature (82 to 93 °C [180 to 200 °F]).
2. Change the oil filter element every 500 hours. Drain and refill the system every 1000 hours or 6 months.

Troubleshooting

The following data is presented as an aid to locating the source of difficulty in a malfunctioning unit. It is necessary to consider the torque converter charging pump, transmission, oil cooler, and connecting lines as a complete system when checking for the source of trouble, since the proper operation of any unit therein depends greatly on the condition and operation of the others. By studying the principles of operation together with the data in this section, it may be possible to correct any malfunction which may occur in the system. Troubleshooting procedures basically consist of hydraulic checks.

Hydraulic Checks

Before checking the transmission/torque converter and associated hydraulic system for pressures and rate of oil flow, it is essential that the following preliminary checks be made.

1. Check oil level in transmission. This should be done with oil temperature at 82 to 93 °C (180 to 200 °F). Do not attempt these checks with cold oil.
2. To bring the oil temperature to this level, it is necessary to either work the machine or stall out the converter. When it is impractical to work the machine, stall out the converter as follows.
 - a. Apply the parking brake.
 - b. Position the shift lever to forward and high speed.
 - c. Accelerate the engine to between half and three-quarter throttle.

CAUTION

Full throttle stall speeds for an excessive length of time will overheat the torque converter.

- d. Hold converter stalled until desired temperature is reached.

NOTE: Always make all troubleshooting checks with the converter outlet temperature at least 82.3 to 93.3 °C (180 to 200 °F).

Troubleshooting Procedures

SYMPTOM	PROBABLE CAUSE	REMEDY
1. Low clutch pressure.	a. Low oil level.	a. Fill to proper level. Refer to LUBRICATION (pg 9-1).
	b. Clutch pressure regulating valve spool stuck open.	b. Clean valve spool and housing.
	c. Faulty charging pump.	c. Replace pump.
	d. Broken or worn clutch shaft or piston sealing rings.	d. Replace clutch shaft or sealing rings, as applicable.
	e. Clutch piston bleed valve stuck open.	e. Clean bleed valves thoroughly.
2. Low converter charging pump pressure.	a. Low oil level.	a. Fill to proper level.
	b. Suction screen plugged.	b. Clean suction screen.
	c. Defective oil pump.	c. Replace pump.
3. Overheating.	a. Worn oil sealing rings.	a. Remove, disassemble, and rebuild converter assembly.
	b. Worn oil pump.	b. Replace pump.
	c. Low oil level.	c. Fill to proper level.
4. Noisy converter.	a. Worn oil pump.	a. Replace pump.
	b. Worn or damaged bearings.	b. A complete disassembly will be necessary to determine what bearing is faulty.
5. Lack of power.	a. Low engine RPM at converter stall.	a. Tune engine and check governor.
	b. See "Overheating" and make same checks.	b. Make corrections as explained in "Overheating."

Removal

1. Extend and set the outriggers just enough to take up the slack in the outrigger pads. Chock the wheels.
2. Position the boom over the side and stop the engine.
3. Remove the engine and transmission/torque converter from the crane as an assembly. Refer to *Engine*, page 7-1 in this Section.
4. Remove the hydraulic pumps from the transmission/torque converter. Cover all openings. Refer to *Hydraulic Pumps*, page 2-14 for removal of the pump.

NOTE: The transmission/torque converter weighs approximately 374 kg (824.5 lb) dry.

5. Attach an adequate lifting device to the transmission/torque converter and take up any slack.
6. Remove the hardware securing the drive plate assembly to the flywheel.

7. Remove the hardware securing the transmission/torque converter housing to the engine flywheel housing.

Installation

NOTE: The transmission/torque converter assembly weighs approximately 374 kg (824.5 lb) dry.

1. If a new transmission/torque converter is to be installed, remove all fittings and brackets from the old one and install them in the same locations on the new transmission/torque converter.
2. Install the piston and single section hydraulic pumps on the transmission/torque converter. Refer to *Hydraulic Pumps*, page 2-14 for installation of the hydraulic pump.
3. Position the transmission/torque converter to the engine with the lifting device.
4. Remove all burrs from the flywheel mounting face and nose pilot bore. Clean the drive plate surface with solvent (Figure 7-11).

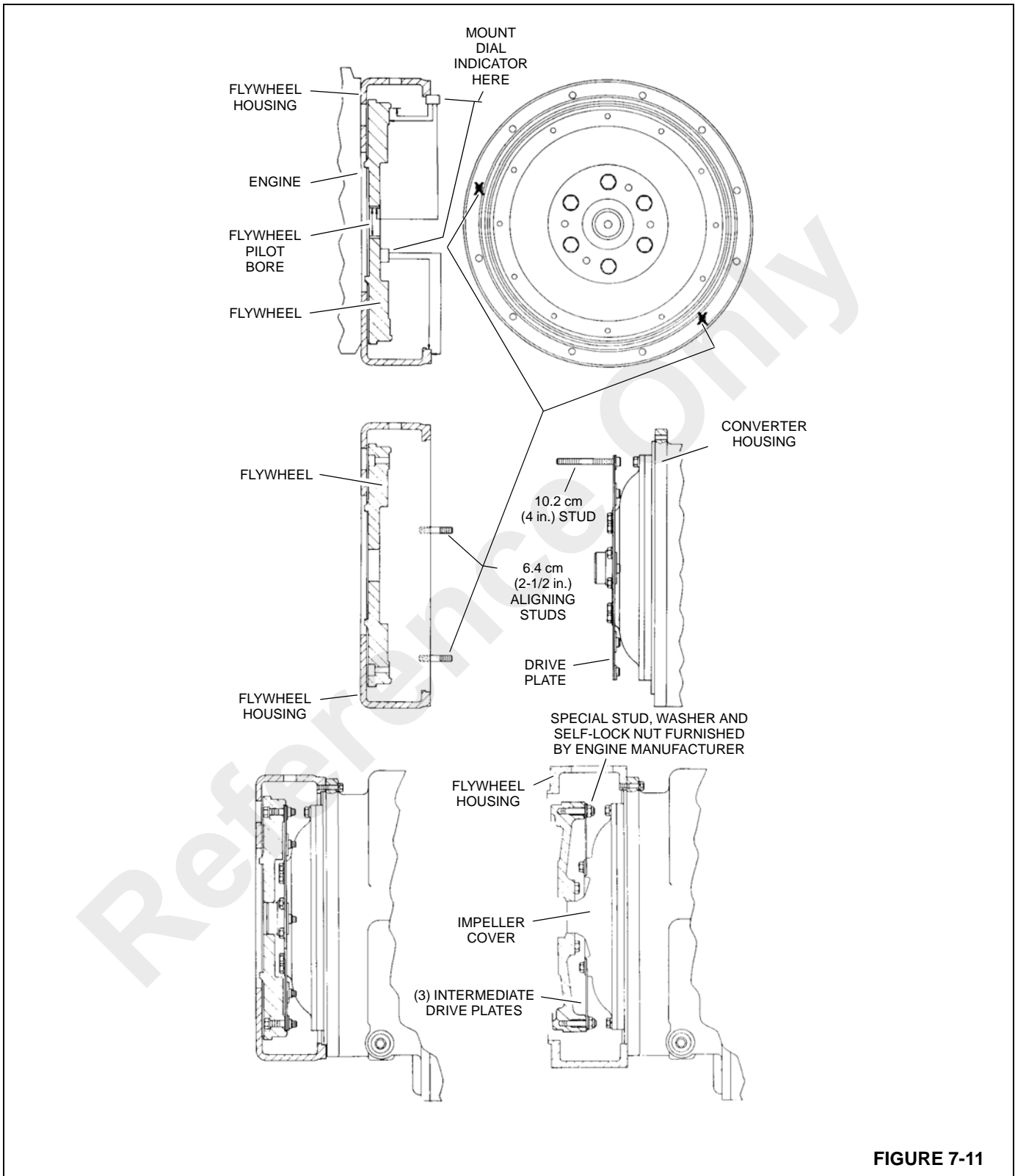

FIGURE 7-11

5. Check the engine flywheel and housing for conformance to standard S.A.E. No. 3-S.A.E. J-927 tolerance specifications for bore size, pilot bore runout and mounting face flatness. Measure and record engine crankshaft end play.
6. Install two 63.5 mm (2.50 in) long transmission to flywheel housing guide studs in the engine flywheel housing as shown in the figure titled Transmission/Torque Converter Installation. Rotate the engine flywheel to align a drive plate mounting screw hole with the flywheel housing front access hole.
7. Install a 101.6 mm (4.00 in) long drive plate locating stud 0.3750-24 fine thread in a drive plate nut.
8. Rotate the transmission/torque converter to align the locating stud in the drive plate with the flywheel drive plate mounting screw hole positioned in step 6. Locate the transmission on the flywheel housing, aligning the drive plate to the flywheel and the transmission to the flywheel housing guide studs. Install the transmission to flywheel housing nuts and washers. Tighten the bolts to 41 to 43 Nm (30 to 32 lb-ft). Remove the transmission to engine guide studs. Install the two remaining bolts and washers and tighten the bolts to 41 to 43 Nm (30 to 32 lb-ft).
9. Remove the drive plate locating stud. Install one drive plate attaching screw and lockwasher. Snug the screw but **do not tighten**. **NOTE:** Some engine flywheel housings have a hole located on the flywheel housing circumference in line with the drive plate screw access hole. A screwdriver or pry bar used to hold the drive plate against the flywheel will facilitate installation of the drive plate screws. Rotate the engine flywheel and install the remaining seven flywheel to drive plate attaching screws and lockwashers. Snug the screws but **do not tighten**. After all eight screws and lockwashers have been installed, torque the screws to 38 to 41 Nm (28 to 30 lb-ft). This will require torquing each screw, then rotating the engine flywheel until all eight screws have been torqued.
10. Measure the engine crankshaft end play after the transmission/torque converter has been completely installed on the engine flywheel. This value must be within 0.025 mm (0.001 in) of the end play recorded in step 5.
11. Install the engine and transmission/torque converter in the crane as an assembly. Refer to *Engine Installation*, page 7-5.
12. Service the crane as required in Servicing the Crane After Transmission/Torque Converter Overhaul (pg 7-25) in this section.
13. Cycle all functions and observe for proper operation.

Servicing the Crane After Transmission/Torque Converter Overhaul

The transmission/torque converter and its allied hydraulic system are important links in the drive line between the engine and the wheels. The proper operation of either the unit or the system depends greatly on the condition and operation of the other; therefore, whenever repair or overhaul of the transmission/torque converter is performed, the balance of the system must be considered before the job can be considered completed.

After the overhauled or repaired transmission/torque converter has been installed in the crane, the oil cooler and connecting hydraulic system must be thoroughly cleaned. This can be accomplished in several ways, and a degree of good judgement must be exercised as to the method employed.

The following are considered the minimum steps to be taken:

1. Drain the entire system thoroughly.
2. Disconnect and clean all hydraulic lines. Where feasible, hydraulic lines should be removed from the machine for cleaning.
3. Replace oil filter elements, cleaning out the filter cases thoroughly.
4. The oil cooler must be thoroughly cleaned. The cooler should be back flushed with oil and compressed air until all foreign material has been removed. Flushing in the direction of normal oil flow will not adequately clean the cooler. If necessary, the cooler assembly should be removed for cleaning, using oil, compressed air and a steam cleaner for that purpose.

CAUTION

Do not use flushing compounds for cleaning purposes.

5. Remove the drain plug from the transmission/torque converter and inspect the interior of the unit housing, gears, etc. If the presence of considerable foreign material is noted, it will be necessary for the unit to be removed, disassembled, and cleaned thoroughly. It is realized this entails extra labor, however, such labor is a minor cost compared to the cost of difficulties which can result from the presence of such foreign material in the system.
6. Assemble all components and use only the type oil recommended. Fill the transmission through the fill pipe until fluid is at the top of the fill range on the dipstick. Run the engine for two minutes at idle (950 rpm) to prime the torque converter and hydraulic lines. Recheck the level of oil in the transmission with the engine running at idle (950 rpm). Add oil as necessary to bring the level to the LOW mark on the dipstick. After the oil temperature

reaches 82 to 93 °C (180 to 200 °F), add oil to bring the level to the FULL mark on the dipstick.

7. Recheck all drain plugs, lines, connections, etc., for leaks and tighten where necessary.

Lubrication

Type Of Oil

Hydraulic Oil (HYDO) or equivalent. Refer to *LUBRICATION*, page 9-1.

Capacity

System Capacity (includes torque converter, lines, and transmission) - Approximately 24 l (25 qt).

Check Period

Check oil level every 10 hours or DAILY with engine running at 950 RPM and oil at 83 to 94 °C (180 to 200 °F). Maintain oil level to FULL mark.

Normal Drain Period

NOTE: Normal drain periods and filter change intervals are for average environmental and duty-cycle conditions. Severe or sustained high operating temperatures or very dusty atmospheric conditions

will cause accelerated deterioration and contamination. For extreme conditions, judgment must be used to determine the required change intervals.

Every 500 hours, change oil filter element. Every 1000 hours or 6 months, drain and refill system as follows: Drain with oil at 66 to 93 °C (150 to 200 °F).

NOTE: It is recommended that filter elements be changed after 50 and 100 hours of operation on new and rebuilt or repaired units, then at normal intervals thereafter.

- a. Drain transmission and remove pump screen. Clean screen thoroughly and replace, using a new gasket.
- b. Remove and discard oil filters. Clean filter housing and install new filters.
- c. Refill transmission to LOW mark.
- d. Run engine at 950 RPM to prime converter and lines.
- e. Recheck level with engine running at 950 RPM and add oil to bring level to LOW mark. When oil temperature is hot (83 to 94 °C [180 to 200 °F]), make final oil level check. BRING OIL LEVEL TO FULL MARK.

SECTION 8 UNDERCARRIAGE

SECTION CONTENTS

Axles	8-1	Maintenance	8-17
Description	8-1	Service Brakes	8-18
Maintenance	8-2	Description	8-18
Wheels and Tires	8-7	Maintenance	8-18
Steering Systems	8-10	Corrosion Protection	8-22
Description	8-10	Parking Brake Actuator	8-24
Theory of Operation	8-10	Description	8-24
Maintenance	8-11	Maintenance	8-24
Rear Steering System	8-12	Parking Brake	8-25
Hydraulic Pumps	8-13	Description	8-25
Front Steering Control Valve	8-13	Maintenance	8-25
Integrated Outrigger/Rear Steer Manifold	8-13	Park Brake Valve	8-27
Steer Cylinders	8-14	Description	8-27
Rear Axle Oscillation Lockout System	8-15	Outriggers	8-27
Description	8-15	Outrigger Circuit	8-27
Axle Oscillation Lockout Cylinders	8-15	Outrigger Beam	8-31
Brake System	8-16	Extension Cylinder	8-35
Description	8-16	Jack Cylinder	8-36
Theory of Operation	8-16	Outrigger Control Valves	8-38

AXLES

Description

To provide maximum maneuverability, both the front and rear axles are steerable. The rear axle (Figure 8-3) is mounted on a pivoting cradle (fifth wheel) which allows the axle to oscillate while traversing uneven terrain. The front axle (Figure 8-4) is bolted directly to the frame. All four wheels utilize a hydraulic braking system. The axles are equipped with disc type brakes. A disc-type parking brake is mounted on the front axle input shaft, at the transmission.

Each axle incorporates a single reduction carrier with hypoid gearing mounted in the axle center. The final reduction is of planetary design spur gearing built into the wheel hubs.

The design of these axles permits the hypoid gearing of the differential carrier and the axle shafts to carry only a nominal torsional load while at the same time providing the highest practical numerical gear reduction at the wheels.

The hypoid pinion and differential assembly of the first reduction are supported by tapered roller bearings. The pinion bearing preload is adjusted and maintained by a hardened precision spacer between the inner and outer bearing. The differential tapered bearing preload is adjusted and maintained by the positioning of the threaded adjusting rings in the carrier leg and cap bores.

In the planetary wheel ends, the spur teeth of the sun gear mesh with teeth of the planet spur gears. The planet spur gears rotate on planet pins which are mounted in a spider. The planet spur gear teeth in turn mesh with teeth of the floating ring gear.

Power is transmitted by the hypoid gear set in the differential carrier to the axle shafts and the sun gear of the final reduction, through the revolving planet gears, and into the planetary spider which drives the wheel hub.

As an option, the front axle and rear axle may be provided with a differential lock. When in the locked mode, the axle shafts and the differential are locked together and there is no differential action between the wheels.



Maintenance

NOTE: The axles do not have to be removed from the crane to remove the planetary wheel ends or the drive units.

Removal

1. Using the outriggers, raise the wheels off the ground.
2. Install blocking under the frame at the outboard ends of the four outrigger boxes.

CAUTION

Do not disassemble drive lines when removing them from the crane. Dirt can enter the spline and cannot be purged. In addition, the drive lines are assembled in a specific orientation when manufactured and can easily be incorrectly reassembled.

3. Disconnect and remove the drive line from the applicable axle. Do not disassemble the drive lines. Refer to *POWER TRAIN*, page 7-1.
4. Tag, disconnect, and cap the hydraulic brake line at each wheel.
5. Tag, disconnect, and cap the hydraulic lines to the steer cylinders.

6. On the left side of the rear axle only, tag and disconnect the electrical wires from the rear wheels not centered switch.

NOTE: Each tire and wheel assembly weighs approximately 1660 kg (3660 lb).

7. Remove the tire and wheel assemblies from the axle.

NOTE: Each axle weighs approximately 1053 kg (2321 lb) with oil.

8. Position jacks, which are capable of handling the weight of the axle, under the axle for support.

9. Remove the eight nuts, washers, and capscrews securing the axle to the frame/cradle (Figure 8-1) (Figure 8-2).

10. Lower the axle to the ground and remove it to a clean working area.

11. If a new axle is to be installed, remove the following from the old axle and install them on the new one.

- a. The steer cylinders. Refer to Steer Cylinders in this section.
- b. The rear wheels not centered switch actuator bracket (rear axle only).

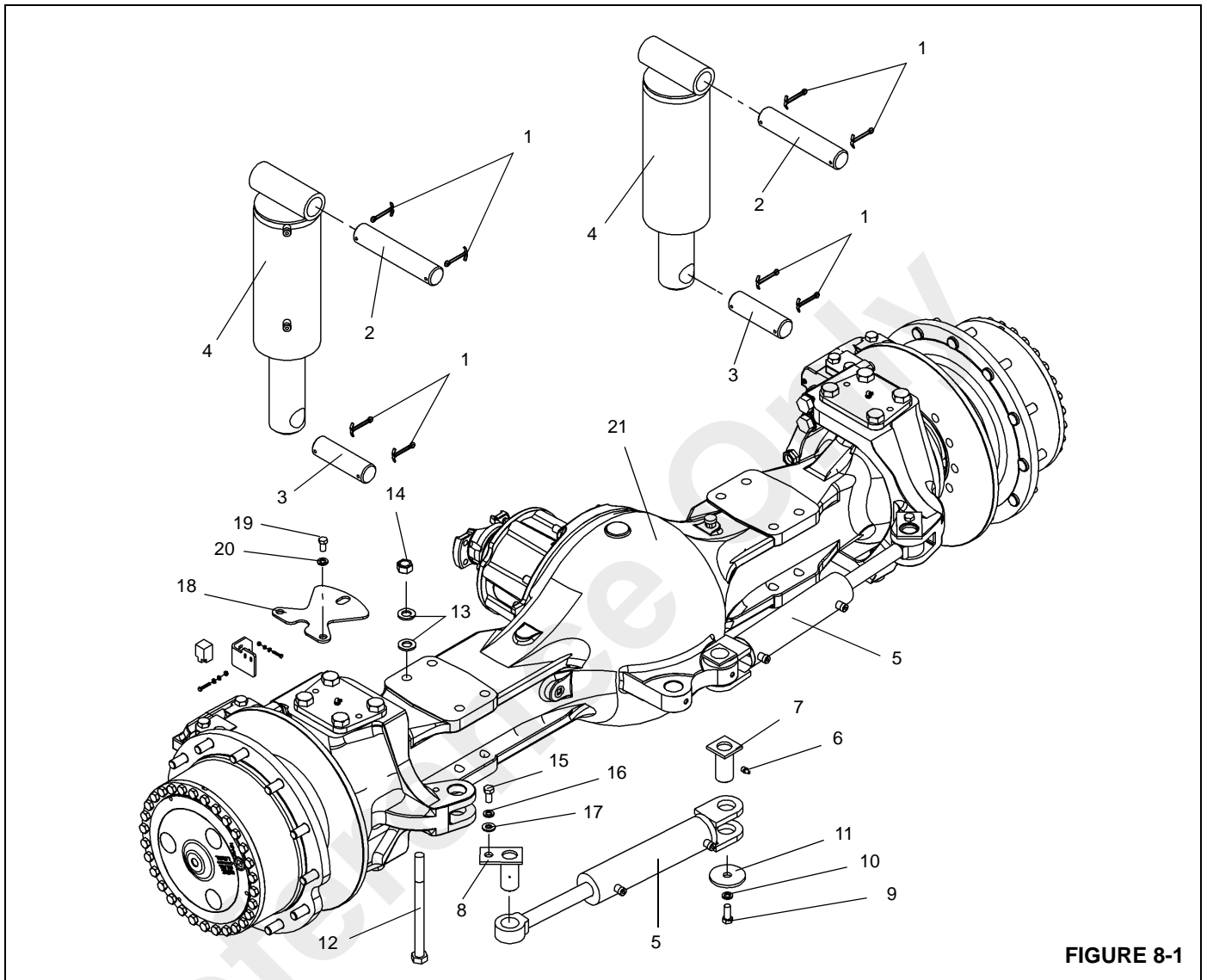

FIGURE 8-1

Item	Description
1	Cotter Pin
2	Pin
3	Pin
4	Lockout Cylinder
5	Steer Cylinder
6	Grease Fitting
7	Pin Weld
8	Pin Weld
9	Capscrew
10	Lockwasher
11	Flatwasher

Item	Description
12	Capscrew
13	Washer
14	Hex Nut
15	Capscrew
16	Lockwasher
17	Flatwasher
18	Sensor Plate
19	Capscrew
20	Lockwasher
21	Rear Axle

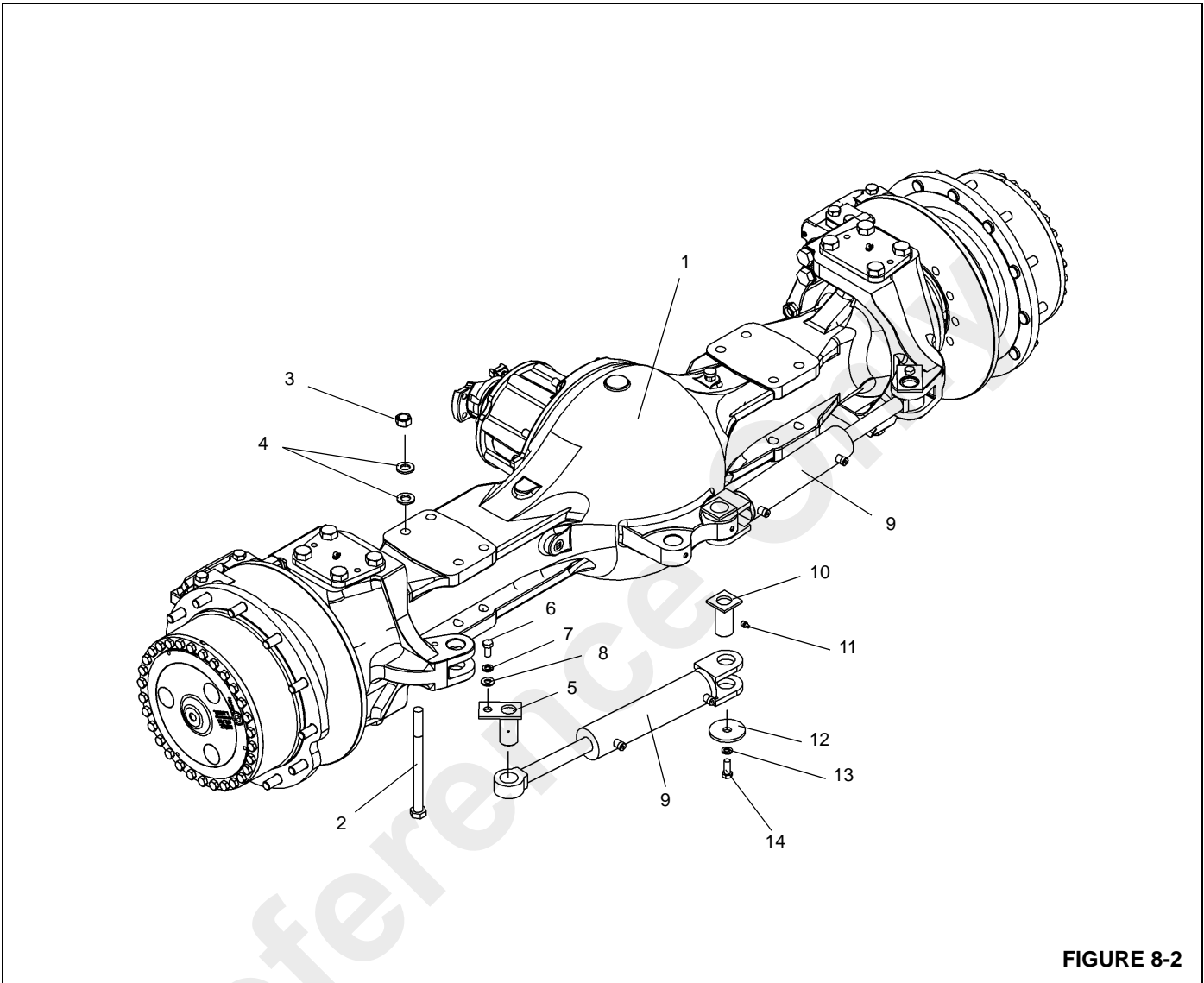

FIGURE 8-2

Item	Description
1	Front Axle
2	Capscrew
3	Hex Nut
4	Washer
5	Pin Weld
6	Capscrew
7	Lockwasher

Item	Description
8	Flatwasher
9	Steer Cylinder
10	Pin Weld
11	Grease Fitting
12	Flatwasher
13	Lockwasher
14	Capscrew

Cleaning

Completely assembled axles may be steam cleaned on the outside only, to facilitate initial removal and disassembly, providing all openings are closed. Breathers, vented shift units, and all other openings should be tightly covered or closed to prevent the possibility of water entering the assembly.

Installation

1. If a new axle is to be installed, remove the following from the old axle and install them on the new one.
 - a. The steer cylinders. Refer to Steer Cylinders in this section.
 - b. The rear wheels not centered switch actuator bracket (rear axle only).
2. Position the axle under the crane on jacks which are capable of handling the weight of the axle.
3. Raise the axle into place and secure with the eight attaching capscrews, washers and nuts. Torque the capscrews; see *Fasteners and Torque Values*, page 1-11.
4. Install the wheels onto the axle. Refer to *Wheels and Tires*, page 8-7.
5. Connect the hydraulic lines to the steer cylinder as tagged during removal.
6. Connect the hydraulic brake line to each wheel as marked during removal.
7. On the left side of the rear axle only, connect the electrical wires to the rear wheels not centered switch. Refer to *Rear Steer Indicator Adjustment Procedure*, page 8-5 and adjust the switch.
8. Connect the drive line to the applicable axle. Refer to *Drive Lines*, page 7-21.
9. Refer to Brake System in this section and bleed the hydraulic brake system.
10. Remove the blocking under the outrigger beams and retract the outriggers to lower the wheels to the ground.

Wheel Alignment Check Procedure

1. Check the axle for wheel alignment. The wheels are to be straight ahead with no toe-in or toe-out. Adjust if necessary by turning the tie rod ends in the direction necessary.
2. Turn the wheels to the extreme left. Check the clearance between the inside of the tire and the nearest object. If the clearance is less than 25 mm (1.0 in) on the rear axle or 13 mm (0.5 in) on the front axle, adjust the axle stop to provide clearance. Do not adjust axle stop if clearance is greater than 25 mm (1.0 in).

Check the steer cylinders to see that they are not bottomed out. To check the steer cylinders, remove the pin at the rod end and apply pressure to move the cylinder rod. The cylinder rod should travel a minimum of 3.0 mm (0.12 in).

3. Turn the wheels to the extreme right and repeat step 2 for the right side.

Rear Steer Indicator Adjustment Procedure

1. Ensure the wheels are straight ahead.

NOTE: Refer to Figure 8-3 to perform the following adjustments.

2. Ensure proximity sensor switch is centered in the slot of the sensor plate bolted to the top of the axle trunnion cap. Adjust by moving the sensor mounting bracket.
3. Ensure a maximum gap of 5 mm (0.2 in) exists between the sensor switch and the sensor plate. Adjust by loosening switch mounting bolts and moving switch up or down on the mounting bracket. Tighten the mounting bolts.
4. Turn the rear wheels to verify proper operation. The Rear Wheels Not Centered indicator in cab should not be illuminated when rear wheels are centered and the sensor switch is centered in the slot of the sensor plate.

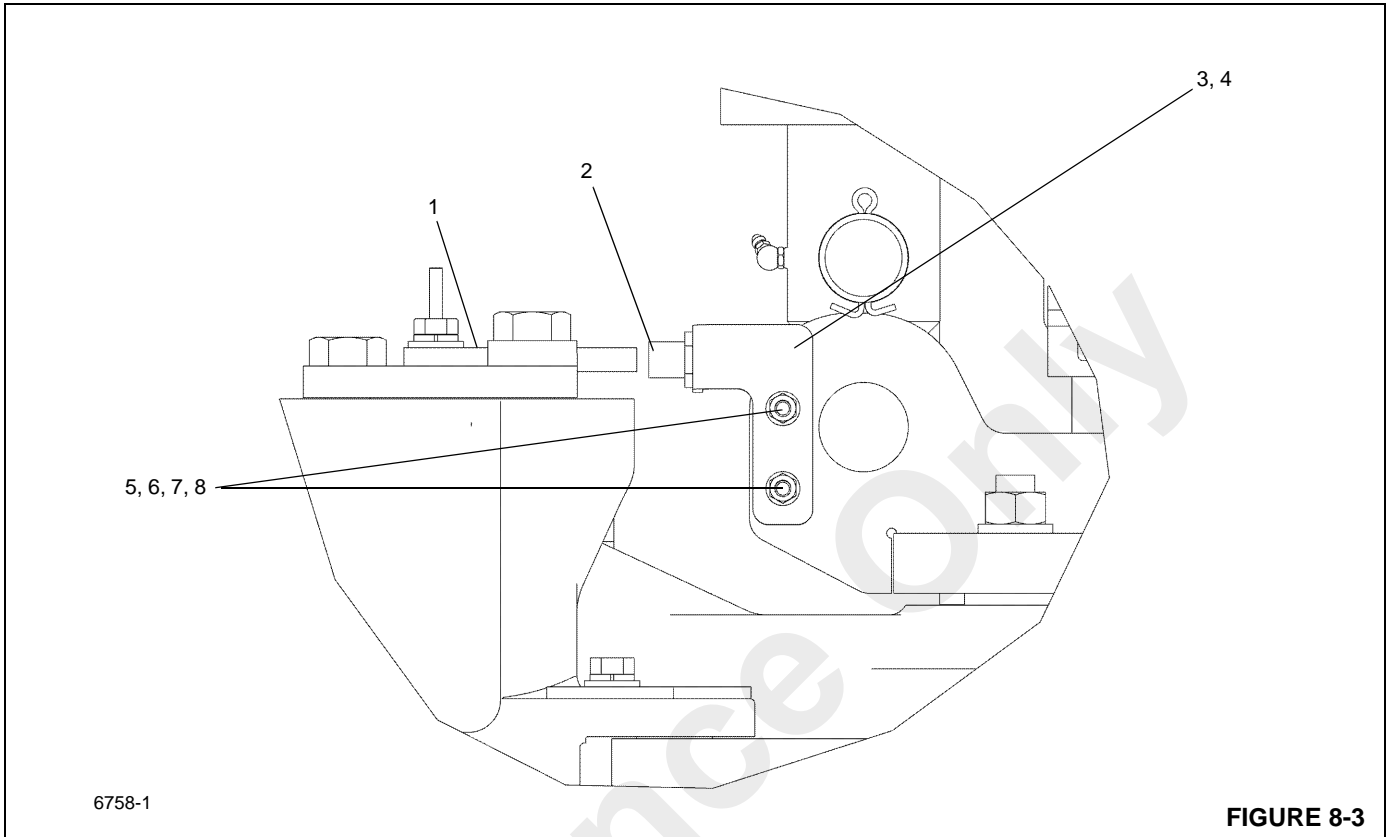

Item	Description
1	Sensor Plate
2	Proxy Switch
3	Bracket
4	Rear Steer Bracket Shim
5	Capscrew
6	Hex Nut
7	Flat Washer
8	Lock Washer

Wheels and Tires

Description

The standard tire size for this unit is 20.5 x 25 -24 ply. A size 16.00 x 25 -28 ply tire is also available.



WARNING

Possible equipment damage and/or personal injury!

Driving the crane with a tire under inflated at 80% or less of its recommended pressure can cause the wheel and/or tire to fail. Per OSHA Standard 1910.177(f)(2), when a tire has been driven under inflated at 80% or less of its recommended pressure, it must first be completely deflated, removed from the axle, disassembled, and inspected before re-inflation.

CAUTION

Do not mix tires and rims of different manufacturers.

Each wheel assembly (tire and rim) is mounted on the planetary hub with 12 grade 8 lug nuts.

NOTE: The tire diameters, widths, and weights may vary slightly depending on the tire manufacturer.

Off-highway tires are designed to operate with a certain sidewall deflection or bulge. Correct air pressure ensures proper deflection which, in turn, ensures proper traction, flotation, support of load, and prevents excessive flexing of the tire. Over inflation increases rim stresses, which results in lowered rim life.

Refer to and adhere to the inflation pressures in the Load Chart Book in the crane cab.

Maintenance



WARNING

Do not attempt to demount or mount tires without proper training. The high pressures involved can cause tire and rim parts and tools to fly with explosive force, if proper procedures are not used, causing severe injury or death to personnel and damage to the crane and surrounding area.

Mounting Wheel Assemblies

NOTE: Do not lubricate the wheel studs or lug nuts.

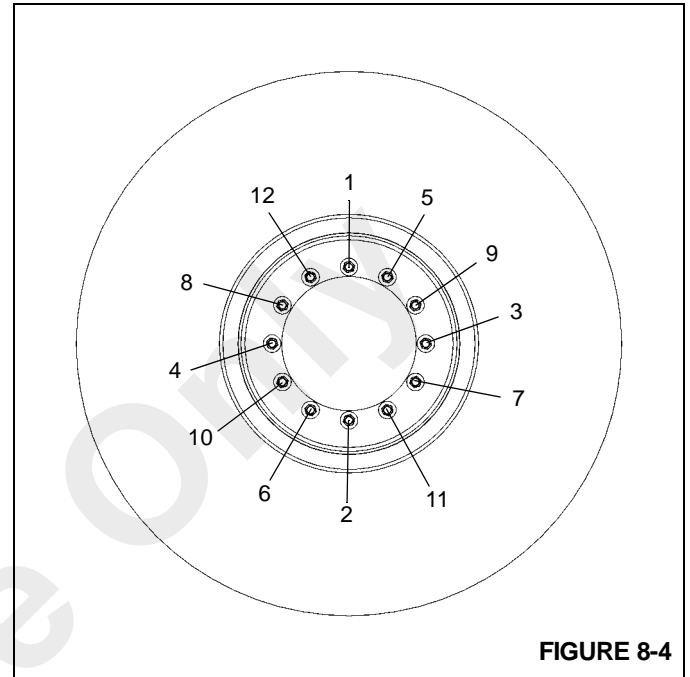

FIGURE 8-4

NOTE: Prior to wheel installation, remove any dirt or grease from wheel mounting surface.

1. Position the wheel assembly on the mounting studs being careful not to damage threads. Install the lug nuts and tighten them to 68 Nm (50 lb-ft) in the sequence shown in (Figure 8-4)
2. Ensure the wheel assembly is positioned properly on the hub.
3. Torque the lug nuts 461 to 488 Nm (340 to 360 lb-ft) in the sequence shown in (Figure 8-4).
4. Retorque lug nuts after approximately one hour of travel.

Typical Wear Patterns

Incorrect Tire Pressure

Too high air pressure [(Figure 8-5), View 1] gives rapid wear in the middle of the tire. Too low air pressure [(Figure 8-5), View 2] gives rapid shoulder wear.

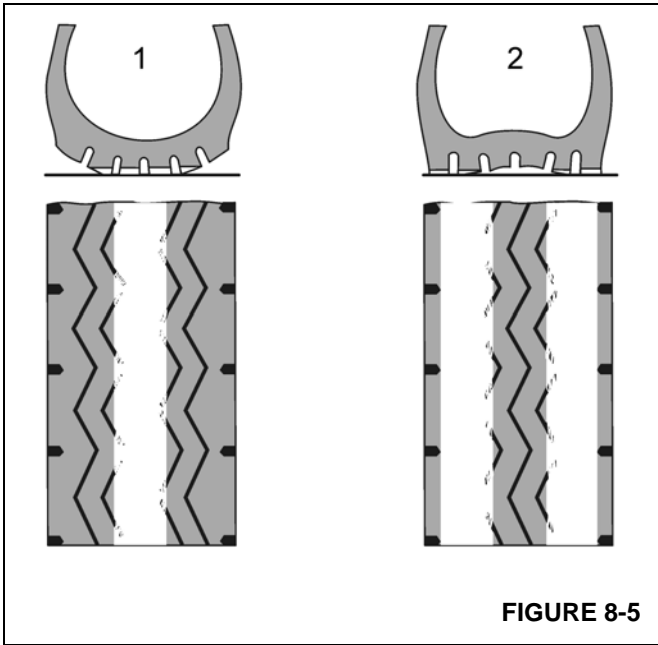

FIGURE 8-5

Incorrect Camber

Incorrect camber gives abnormal wear on one half of the tire.

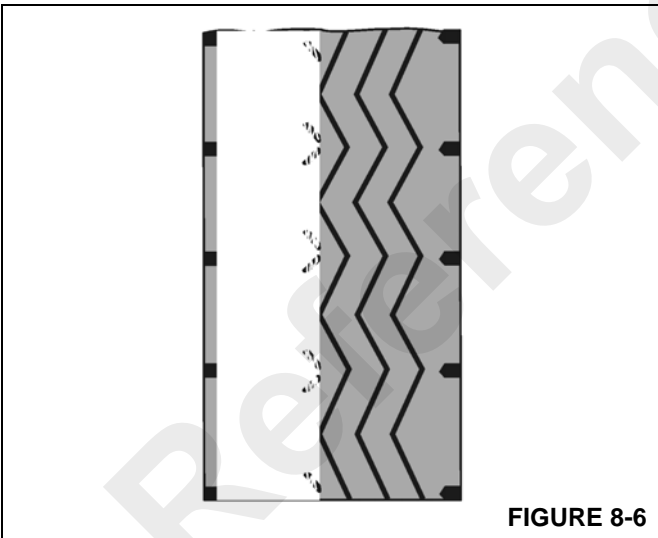

FIGURE 8-6

Incorrect Toe and Axle Alignment

Incorrect toe has a “scrubbing” effect on the front wheels that shows in rapid shoulder wear or across the tire.

Incorrect axle alignment has a “scrubbing” effect on all wheels.

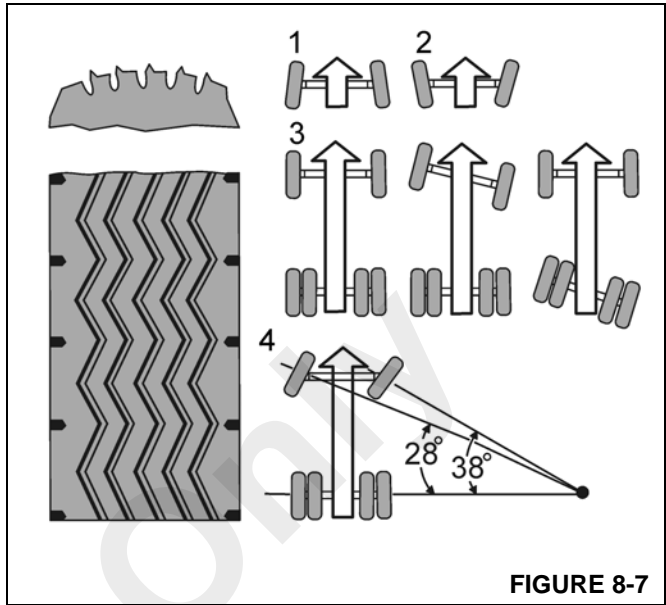

FIGURE 8-7

Item	Description
1	Incorrect Toe-In
2	Incorrect Toe-Out
3	Out-of-line Axles
4	Steering Arm Defect

Incorrect Caster and Wheel Imbalance

Incorrect caster or wheel imbalance shows as spot wear that is either in the middle of the tire or extends to the shoulder.

This rapidly wears the mechanical parts of steering linkage, kingpin and wheel bearing.

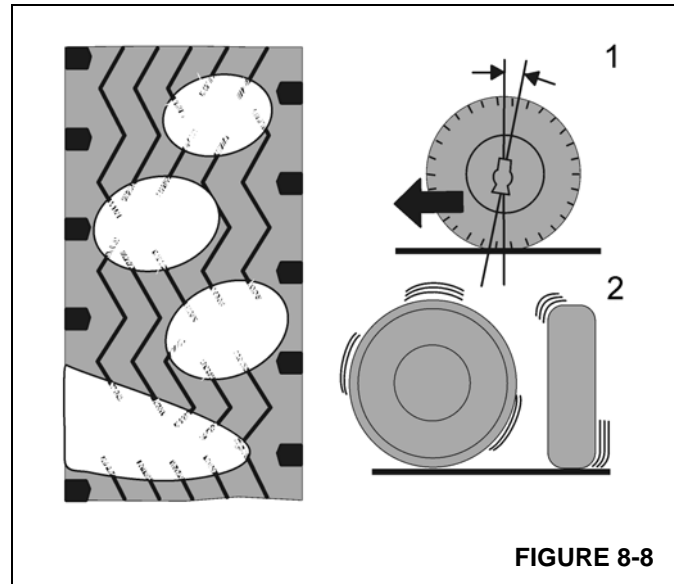
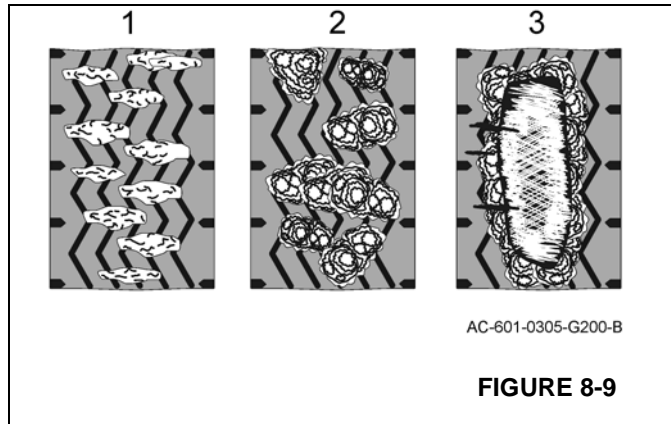

FIGURE 8-8

Cuts in the Tire Tread

Cuts are due to poor roads, air pressure too high or incorrect tire type for the application.



Item	Description
1	Cuts
2	Flaking Cuts
3	Rubber Flaking

Spot Wear

Sudden braking, locking brakes or out-of-round brake drums give spot wear.

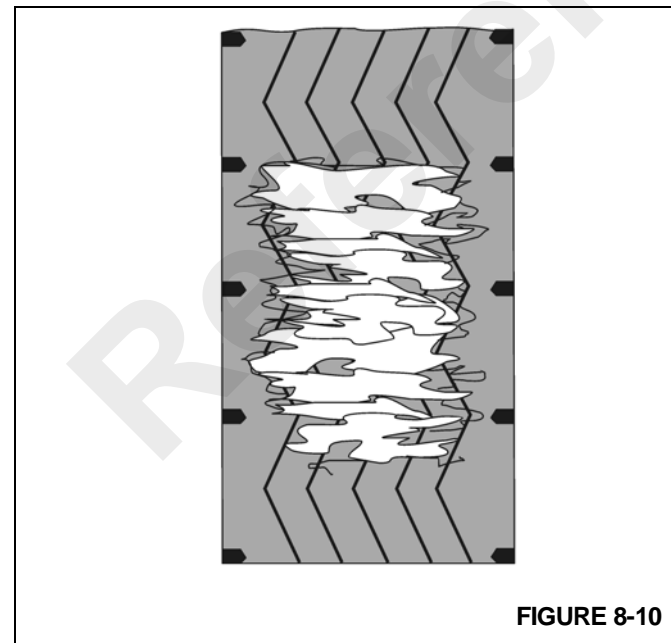

Feathered Edges

Normal occurrence on non-driving wheels on good roads and high mileage.

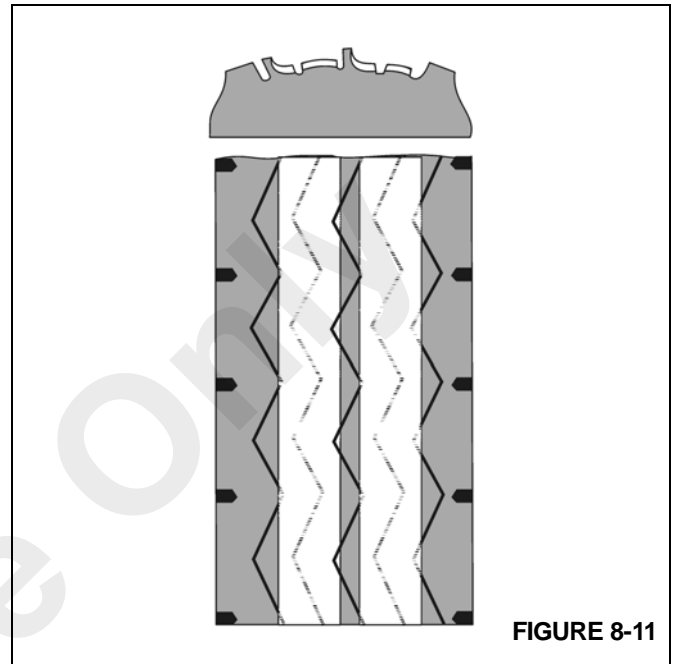

Cupping

Cupping is a normal occurrence that depends on the tread pattern - the higher the load, the greater the wear.

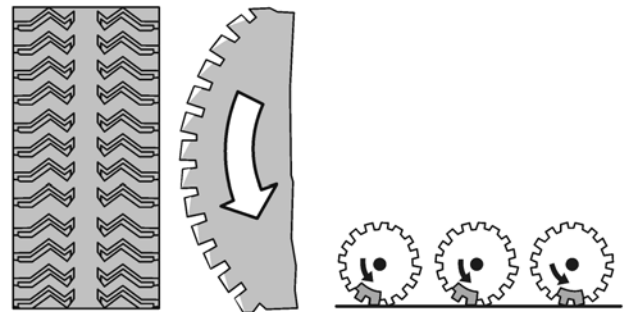

AC-601-0305-G197

FIGURE 8-12

STEERING SYSTEMS

Description

To maximize maneuverability, the crane can be steered by the front axle, the rear axle, or by the front and rear axles simultaneously. The crane utilizes two separate steering systems, one to control front axle steering and one for rear axle steering.

Front Steering System

NOTE: Pump figures in following text are theoretical.

The front steering system consists of a hydraulic pump, load sense steer priority flow divider valve (part of the swing directional control valve), load sense steering control valve, and two steer cylinders.

The hydraulic pump is driven by the engine and supplies a hydraulic flow of 82.9 l/min (21.9 gpm) to the load sense steering priority flow divider. The load sense steer priority flow divider valve provides 26.5 l/min (7 gpm) to the load sense steering control valve and the remainder to the swing system.

When the steering wheel is turned, the load sense steering control valve sends a load sense signal to the load sense steer priority flow divider. As the load sense pressure increases, the priority flow divider spool shifts to direct oil from the hydraulic pump to the steering control valve, and to direct oil from the L (left) port and R (right) port of the steering control valve to the steer cylinders.

Rear Steering System

The rear steering system is controlled through a section of the integrated outrigger/rear steer manifold and consists of

the control valve and two steer cylinders. It is activated by the rear steer control switch located on the left armrest in the cab.

A rear steer indicator system is provided to indicate when the rear wheels are not centered. This system consists of an indicator light located on the front console in the cab and a switch located on the right side of the rear axle. When the rear wheels are turned to the left or right, the amber indicator light will illuminate.

Theory of Operation

Front Steering System

A hydraulic oil flow from pump number 2 flows through port 5 of the hydraulic swivel to the steer/swing directional control valve. Regulated flow from the steer priority flow divider valve is routed to the steering control valve upon turning of the steering wheel and pressurizing of the load sense line. The steering control valve routes the oil to the appropriate ends of the front steer cylinders to turn the wheels in the desired direction.

Rear Steering System

Hydraulic flow from pump number 1 is directed through the integrated outrigger valve to the rear steer/outrigger manifold. When the rear steer control switch in the cab is positioned to steer left (push top of switch) or steer right (push bottom of switch), a signal is sent to the directional control valve spool, routing the supply pressure to the appropriate ends of the rear steer cylinders to turn the wheels in the desired direction.

Maintenance

Front Steering System

Troubleshooting

Table 8-1

Symptom	Probable Cause	Solution
1. Hard to steer left and right.	a. Hydraulic oil low.	a. Refill hydraulic reservoir. Refer to Section 9 - LUBRICATION
	b. Clogged or loose hydraulic lines or fittings.	b. Clean or tighten lines or fittings. (Refer to your Manitowoc Crane Care Parts Manual)
	c. Defective flow divider valve(s).	c. Repair or replace valve(s).
	d. Defective steering control valve.	d. Repair or replace valve.
	e. Defective hydraulic pump.	e. Repair or replace pump.
2. Hard to steer either left or right.	a. Clogged or loose hydraulic lines or fittings.	a. Clean or tighten lines or fittings. Refer to Section 9 - LUBRICATION
	b. Defective steer cylinder.	b. Repair or replace cylinder.
3. Steering is erratic left and right.	a. Hydraulic oil low.	a. Refill hydraulic reservoir. Refer to Section 9 - LUBRICATION.
	b. Clogged or loose hydraulic lines or fittings.	b. Clean or tighten lines or fittings.
	c. Defective steering control valve.	c. Repair or replace valve.
	d. Defective hydraulic pump.	d. Repair or replace pump.
4. Noisy hydraulic pump caused by cavitation.	a. Hydraulic oil low.	a. Refill hydraulic reservoir. Refer to Section 9 - LUBRICATION
	b. Suction line plugged or too small.	b. Clean line and check for size.
5. Hydraulic pump shaft seal leakage.	a. Worn shaft seal.	a. Replace shaft seal.
	NOTE: If replacing the shaft seal does not stop leakage, the pump should be disassembled and checked for the following:	
	b. Broken diaphragm seal or backup gasket.	b. Replace seal or gasket.
	c. Bearing out of position.	c. Replace bearing.
	d. Excessive internal wear.	d. Replace pump.

Functional Check

A normal periodic functional check of the entire steering system will generally be adequate to ensure satisfactory service.

1. Check all fittings for leakage. An accumulation of moist, black dirt is a good indication of leakage.
2. With the engine running at idle and at full throttle, and with the machine standing still and moving, turn the steering wheel through the full range of travel. Note any speed irregularities and sticky sensation. This may indicate dirt in the fluid. If the steering wheel continues to rotate when started and released, a condition known as Motoring exists. This may also indicate dirty fluid in the system.
3. Ensure the system has adequate power. If there is an indication of hard steering, this can be caused by either

a reduced oil flow to the control valve or a reduced system relief pressure. Adequate oil flow under all conditions can best be checked by timing the full travel of the cylinder with the steered axle unloaded and loaded. If there is a great difference at low engine speed and slight difference at high engine speeds this may indicate a defective pump. Adequate oil pressure can only be determined by connecting a pressure gauge [24 MPa (3500 psi) full scale recommended] at the accessory manifold with swing directional valve gauge test port (GP5). With the engine running at a medium speed, turn the steering wheel to one end of the travel and hold the cylinders at the travel limit briefly, just long enough to read the pressure gauge. Never hold the system at relief pressure for more than a few seconds at a time. The pressure gauge should indicate 17.3 MPa (2500 psi).

Rear Steering System

Troubleshooting

Table 8-2

Symptom	Probable Cause	Solution
1. Rear steering inoperative.	a. Hydraulic oil low.	a. Refill hydraulic reservoir. Refer to Section 9 - LUBRICATION.
	b. Clogged, broken, or loose hydraulic lines or fittings.	b. Clean, tighten, or replace lines or fittings.
	c. Steer cylinder locked.	c. Repair or replace cylinders.
	d. Defective control valve.	d. Repair or replace valve.
	e. Defective steer cylinder(s).	e. Repair or replace cylinder(s).
	f. Lack of electrical signal	f. Check electrical connections/wiring
2. Hard to steer left and right.	a. Hydraulic oil low.	a. Refill hydraulic reservoir.
	b. Clogged or loose hydraulic lines or fittings.	b. Clean or tighten lines or fittings.
	c. Defective steering control valve.	c. Repair or replace valve.
	d. Defective hydraulic pump.	d. Repair or replace pump.
	e. Clogged or loose hydraulic lines or fittings.	e. Clean or tighten lines or fittings.
	f. Defective steer cylinder.	f. Repair or replace cylinder.
	g. Damaged relief.	g. Replace relief valve.

Symptom	Probable Cause	Solution
3. Steering is erratic left and right.	a. Hydraulic oil low.	a. Refill hydraulic reservoir.
	b. Clogged or loose hydraulic lines or fittings.	b. Clean or tighten lines or fittings.
	c. Defective steering control valve.	c. Repair or replace valve.
	d. Defective hydraulic pump.	d. Repair or replace pump.

Hydraulic Pumps

Description

Front Steer

The hydraulic pump is mounted off of drive pads of the torque converter and driven by the engine. Pump number 2 provides the hydraulic flow necessary to power the front steer cylinders and swing circuit. The pump is a gear type pump that provides a flow of approximately 82.9 l/min (21.9 gpm).

Rear Steer

The hydraulic pump is mounted off of drive pads on the torque converter and is driven by the engine. Pump number 1 supplies oil to the integrated outrigger/rear steer valve, boom lift, telescope, hoist and pilot function. The pump is an axial piston pump that provides a flow of approximately 236.2 l/min (62.4 gpm).

Front Steering Control Valve

Description

The steering control valve is located under the dash and is actuated by a conventional steering wheel and steering column, providing precise, full hydraulic steering. Precise steering is accomplished by a metering system within the valve that is directly connected to the steering column and wheel.

Maintenance

Removal

1. Tag and disconnect the electrical connector to the valve.
2. Tag and disconnect the hydraulic hoses from the valve. Cap or plug the lines and ports.
3. Remove the capscrews and washers and remove the valve from the steering column.

Installation

1. Secure the valve to the steering column and secure with the capscrews and washers. Torque the capscrews see Fasteners and Torque Values (pg 1-11).
2. Connect the hydraulic hoses to the ports on the valve as tagged during removal.
3. Connect the electrical connector to the valve as tagged during removal.
4. Verify proper operation of the valve.
5. Check valve and hydraulic connections for leaks. Make repairs as needed.

Integrated Outrigger/Rear Steer Manifold

The integrated outrigger/rear steer manifold controls the outrigger and rear steer circuit. The valve is mounted on the frame center section to the rear of the front axle.

The manifold is made up of two sections; an inlet section and a working section.

The inlet section contains a 17,200 kPa (2500 psi) relief valve and a solenoid valve. The solenoid valve is normally open. It unloads the pump during cranking, and bypasses oil from the inlet port to the tank port. Activation of either the outriggers or the rear steer circuit energizes the solenoid valve to close and allow oil to flow to the selected circuit.

The rear steer section contains a three position four way solenoid controlled directional valve that controls left and right rear steer.

The outrigger section contains a three position four way solenoid controlled directional valve, two check valves and two load sense valves, that controls outrigger extend and retract.

Maintenance

Removal

1. Tag and disconnect the electrical connectors to the valve.
2. Tag and disconnect the hydraulic hoses from the valve. Cap or plug the lines and ports.

3. Remove the capscrews and washers securing the valve to the frame bracket. Remove the valve.

Installation

1. Secure the valve to the frame bracket with the washers and capscrews. Torque the capscrews see *Fasteners and Torque Values*, page 1-11.
2. Connect the hydraulic hoses to the ports on the valve as tagged during removal.
3. Connect the electrical connectors to the valve as tagged during removal.
4. Verify operation as follows:
 - Operate the rear steer left and right to verify smooth operation.
 - On outriggers, swing over the front outriggers to ensure the oscillation cylinders lockout.
5. Check valve and hoses for leaks. Make repairs as needed.

NOTE: For further information on the Integrated Outrigger/Rear Steer Manifold, refer to Section 2 - HYDRAULIC and PRESSURE SETTINGS.

Steer Cylinders

Description

The steer cylinders are mounted on the axles, two cylinders on each axle. The barrel end of each cylinder is attached to the axle housing and the rod end is attached to the steering lug on the axle end. The front cylinders are controlled hydraulically by the steering control valve. The rear cylinders are controlled by the integrated outrigger/rear steer valve.

Maintenance

NOTE: For Disassembly and Assembly procedures, refer to Steer Cylinders in Section 2 - HYDRAULIC and PRESSURE SETTINGS.

Removal

1. Tag and disconnect the hydraulic lines going into the steer cylinder. Cap or plug all openings.
2. Remove the capscrews, flatwashers and spring lockwashers securing each pin weld in the rod end and barrel end of the cylinder.

NOTE: Steer cylinder weighs approximately 9.07 kg (19.9 lb).

3. Remove both pin welds and two thrust washers (rod end only), and remove the cylinder from the axle.

Installation

1. Position the cylinder onto the attachment fittings on the axle and install both pin welds.
2. Secure each pin weld with the capscrew, flatwashers and spring lockwashers. Torque the capscrews see *Fasteners and Torque Values*, page 1-11.
3. Connect the hydraulic lines to the cylinder as tagged during removal.
4. Operate the steering system and check the cylinder for proper operation and any leakage.

REAR AXLE OSCILLATION LOCKOUT SYSTEM

Description

The rear axle oscillation system consists of two lockout cylinders, an axle lockout valve, an axle oscillation relay and an area potentiometer. The lockout cylinders are mounted between a cradle (fifth wheel) and the carrier frame. The axle oscillation lockout valve is located on the left inner center frame rail and hydraulically controls the lockout cylinders.

The area definition potentiometer in the electrical swivel energizes and deenergizes the axle oscillation relay. When the superstructure is more than 6 degrees left or right of directly over the front, the axle oscillation relay is deenergized.

When the axle oscillation relay's contacts are open, the normally closed solenoid valves are deenergized and isolate the lockout cylinders from hydraulic oil supply. This keeps the cylinders from oscillating (moving up and down to damp axle movement) because hydraulic oil cannot leave the cylinders. Instead, the cylinders remain full of hydraulic oil and more rigid.

When the axle oscillation relay's contacts are closed, the solenoid valves are energized and open. This allows hydraulic oil in and out of the cylinders, allowing them to oscillate.

NOTE: For further information on the lockout valve, refer to Section 2 - HYDRAULIC and PRESSURE SETTINGS.

Axle Oscillation Lockout Cylinders

Description

A 12.7 cm (5 inch) diameter bore lockout cylinder is installed on the left and right side of the rear axle. The barrel end of each cylinder is attached to each side of the carrier frame and the rod ends are attached to each side of the cradle (fifth wheel).

The lockout cylinders are connected hydraulically so that hydraulic oil flows from the rod side of the left cylinder to the barrel side of the right cylinder and from the rod side of the right cylinder to the barrel side of the left cylinder.

Maintenance

NOTE: For disassembly and assembly procedures, refer to Axle Oscillation Lockout Cylinder in Section 2 - HYDRAULIC and PRESSURE SETTINGS.

Removal

1. Raise the crane up on outriggers.
2. Rotate the turntable more than 6 degrees in either direction from directly over the front to lock out the oscillation cylinders.
3. Remove the wheel and tire assembly from the axle.
4. Tag and disconnect both hydraulic hoses from the ports on the cylinder. Cap or plug both hoses and the ports on the cylinder.
5. At the rod end of the cylinder, remove one of the cotter pins securing the retaining pin to the cradle attach fitting.
6. Tap out the retaining pin, freeing the rod end from the cradle.
7. At the barrel end of the cylinder, remove one of the cotter pins securing the retaining pin to the frame attach fitting.
8. Tap out the retaining pin and remove the cylinder.

Installation

1. Position the barrel end of the cylinder in the frame attach fitting and tap in the retaining pin.
2. Secure the retaining pin with the cotter pin.
3. Align the rod end of the cylinder in the cradle attach fitting and tap in the retaining pin.
4. Secure the retaining pin with the cotter pin.
5. Remove the caps or plugs from the two hydraulic hoses and the cylinder ports and connect the hoses to the appropriate cylinder ports as tagged during removal.
6. Install the wheel and tire assembly on the axle. Tighten the lug nuts in accordance with the procedure in Wheel And Tire Assemblies in this section.
7. Lubricate both ends of the cylinder using the fittings provided.

BRAKE SYSTEM

Description

The brake system includes all the components necessary for the application of the service brakes and the parking brake.

Service Brakes

The service brakes are full power hydraulic disc brakes which are hydraulically controlled and are used to apply the brake assemblies on all four wheels. The system consists of the tandem brake valve with treadle pedal, the dual accumulator charge valve, two hydraulic accumulators, the brake assemblies, and all the associated hoses and tubing. The operator depresses the pedal on the tandem brake valve, located on the cab floor, and the valve modulates the brake line pressure to the brake assemblies at each wheel. The full powered brake system supplies a high brake system pressure with relatively low reactive pedal forces, while controlling the maximum brake line pressure. The service brake dual accumulator charge valve regulates flow to the hydraulic accumulators to provide fully powered independently separate, primary (front) and secondary (rear), service brake circuits. Hydraulic pressure is constantly maintained in the brake circuits by the accumulators and the charging valve.

NOTE: For Description and Maintenance of the tandem brake valve with treadle pedal, the accumulators, and the dual accumulator charge valve, refer to VALVES in Section 2 - HYDRAULIC and PRESSURE SETTINGS.

Parking Brake

The parking brake is a hydraulic release, spring apply, disc-type brake, located on the transmission. The system consists of a two-position switch, a three-way solenoid valve, actuator, one brake assembly, and all the associated hardware and tubing. The selector switch, located on the steering column in the cab, is used to activate the solenoid valve which controls the park brake actuator, which applies and releases the park brake.

Theory of Operation

Service Brakes

Braking begins when the operator depresses the brake pedal in the cab. Mechanical linkage transfers the force created by the lever action of the brake pedal to the hydraulic brake valve which modulates the brake line pressure to the brake assemblies at each wheel.

Hydraulic oil from hydraulic pump number 2 flows to swivel port 5 to the accessory manifold to the dual accumulator charge valve. The dual accumulator charge valve charges the accumulators from the open center circuit upon demand and within its present operating charge rate and the high limit pressure setting. However, when the open center circuit pressure reaches the brake relief setting, which is higher than the high accumulator charge limit, then the accumulators will be charged to the regulated maximum pressure setting. The dual accumulator charge valve regulates flow to the hydraulic accumulators to provide fully powered independently separate, primary (front) and secondary (rear), service brake circuits. Hydraulic pressure is constantly maintained in the brake circuits by the accumulators and the charging valve. The charged accumulators supply pressurized fluid to the closed tandem brake valve.

After the accumulators are fully charged, the high limit check opens and all of the pump flow is directed to the excess flow port and on to the front steer and swing circuits. When pressure to the steering or swing circuit becomes greater than accumulator pressure, the main check valve opens and charges the accumulator without the aid of the charging valve. In this condition, the maximum accumulator pressure is the brake circuit relief valve setting of 16 MPa (2320 psi).

Once the operator depresses the brake pedal, the tandem brake valve modulates fluid out to the brakes to provide the means of braking. The tandem brake valve will modulate the pressure in the brake system by increasing or decreasing pressure as required in proportion to the input force from the operator via the brake pedal. The hydraulic force acts within the brake assemblies to force the brake pads against the brake discs, acting to slow wheel rotation. Fully powered separate primary (front) and secondary (rear) braking circuits are provided with independent accumulators. A low pressure warning switch is used to sense the accumulator pressures and warn the operator through visual brake warning indicator light on the cab console in the event the pressure in the accumulators drops to an unsafe operating level. In the event of engine failure, the accumulators are pre-charged with dry nitrogen gas and properly sized to provide power-off stopping capacity for secondary braking.

Parking Brake

Hydraulic flow from the transmission charge pump is routed to the parking brake control valve. When the PARK BRAKE switch is in the ON position, the parking brake solenoid valve shifts to route flow from the hydraulic parking brake actuator back to the transmission sump. The actuator spring pulls on the lever on the brake assembly, applying the parking brake.

Maintenance

Troubleshooting

Symptom	Probable Cause	Solution
1. Brakes are poor.	a. Lining thickness less than 3mm (0.125 in).	a. Replace lining.
	b. Brake pedal operation.	b. Free mechanical linkage.
	c. Restriction or leaks in lines.	c. Check all lines for leaks and restrictions.
	d. Low hydraulic oil flow.	d. Check the hydraulic oil level in reservoir and check flow from the tandem brake valve.
	e. Air in brake lines.	e. Bleed the brakes.
	f. Brake pads/linings are grease-soaked.	f. Replace pads/linings.
	g. Engine not running.	g. Start engine. Due to the operation, the engine must be running to provide full brake power.
	h. Brake relief valve stuck open.	h. Replace the relief valve.
	i. Dual accumulator charge valve not charging	i. Check valve operation and repair or replace valve.
	j. Accumulators not pre-charged.	j. Check accumulator pre-charge.
2. Hard brake pedal with engine running.	a. Pedal travel being interfered with.	a. Check all pedal linkage and ensure it is free and adjusted properly.
3. Brakes lock up.	a. Too much hydraulic flow.	a. Check the flow from the flow divider. Too much flow will cause the brakes to be applied by the oil trapped in the power boost chamber.
	b. Brake pedal push rod improperly adjusted, causing brakes to be always applied.	b. Adjust the push rod linkage so the brake pedal and push rod fully return.
4. Uneven braking or pad wear.	a. Lining thickness less than 3 mm (0.125 in).	a. Replace the lining.
	b. Grease on the pads/linings.	b. Replace the pads/linings.

General

A schedule for the periodic adjustment, cleaning, inspection, and lubrication of brake equipment should be established by the operator on the basis of past experience and severity of operation.

The disc brakes are not adjustable. Brakes should be cleaned, inspected, and linkage lubricated periodically to assure maximum performance.

Bleeding the Brake System

The brake system should be bled whenever air becomes entrapped within the brake system (usually characterized by a spongy feeling during brake pedal application), whenever any brake system line has been opened, or whenever any brake component has been replaced.

Always start at the point in the system that is furthest from the tandem brake valve and work back toward the tandem

brake valve. Bleed every bleeder screw on every caliper/actuator on every wheel. When you complete a bleeder screw, go to the next closest bleeder screw on the same caliper/actuator. When you complete a wheel, go to the furthest bleeder screw on the next closest wheel.

Pressure Bleeding the Brake System.

NOTE: Before bleeding the brake system, ensure the hydraulic accumulators are fully charged.

1. Install the bleeding adapter.
2. Using a clean bleeding tank, fill the tank at least half full with hydraulic oil. Position the tank so it will not have to be moved again until all bleeding is finished.
3. Connect a 241 kPa (35 psi) air source to the bleeder tank.
4. Open the bleeder tank valve and bleed all air out of the hose to be connected to the adapter. Connect the bleeder hose to the adapter and open the bleeder valve.
5. Connect the end of the bleeder hose to the bleeder screw on the caliper/actuator. Submerge the other end in a glass jar partially filled with the proper type of clean hydraulic oil.
6. Open the bleeder screw and allow fluid to flow into the jar until it is a solid stream free of air bubbles. Close the bleeder screw and torque to 11.3 to 13.6 Nm (100 to 120 lb-in).
7. Repeat steps 5 and 6 for the remaining wheel calipers/actuators.
8. Remove the air supply from the bleeder tank.

NOTE: Close the bleeder tank valve and disconnect the hose and the bleeder adapter.

9. Remove the bleeder tank and hose.
10. Remove the bleeder adapter.

Manually Bleeding the Brake System

NOTE: Before bleeding the brake system, ensure the hydraulic accumulators are fully charged.

1. Connect the end of the bleeder hose to the bleed screw on the caliper. Submerge the other end in a jar partially filled with clean hydraulic oil.
2. Open the bleed screw on the caliper/actuator and allow fluid to flow into the jar, while depressing the brake pedal. Depress the brake pedal and close the bleeder screw, then release the brake pedal. Torque the bleeder screw to 11.3 to 13.6 Nm (100 to 120 lb-in).
3. Repeat step 2 until a solid stream free of air bubbles is obtained.

4. Repeat steps 1 thru 3 for the remaining wheel calipers/actuators.

SERVICE BRAKES

Description

The brakes utilized on the axles are hydraulic disc-type brakes. Two brake assemblies are used at each wheel end on the front axle. One brake assembly is used at the wheel end on the rear axle. The action of the brake pads riding against the brake discs acts to slow the rotation of the wheels.

Maintenance

NOTE: To perform maintenance on the brake caliper, remove the tire and wheel assembly. Refer to AXLES in this section.

Removal

Linings

1. Block the wheels.
2. Remove the bolts securing the end plates to one side of the caliper housing. Remove the end plates.
3. Loosen the bleeder screws to release hydraulic pressure in the caliper.

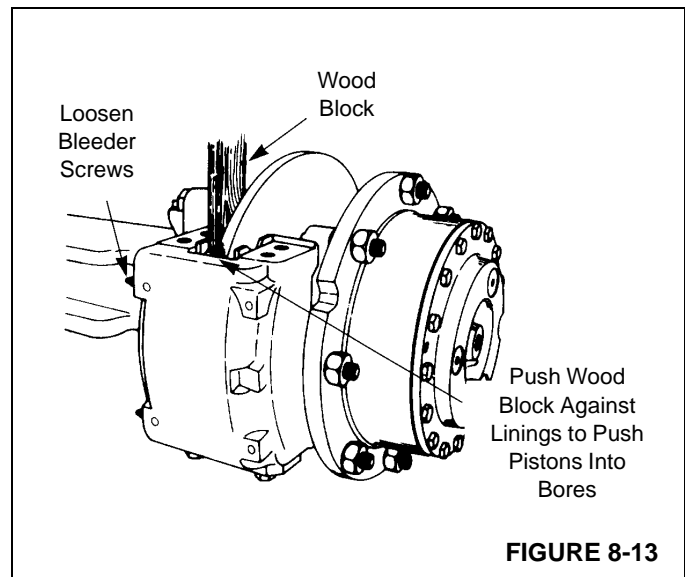

4. Use a piece of wood against the linings as a pry bar to push the pistons completely into the housing. Tighten the bleeder screws (Figure 8-13).
5. Remove the linings from the caliper housing. If necessary, discard the linings.

Caliper

1. Disconnect the hydraulic brake line from the inlet fitting on the caliper. Cap or plug all openings.
2. Remove the linings as described previously.
3. Remove the bolts securing the caliper housing to the mounting bracket. Remove the caliper housing from the mounting bracket. If shims are used mark the position of the shims.

Disassembly**Caliper**

1. Remove the inlet fitting and o-ring from the cylinder cap.
2. Drain and discard the brake fluid.
3. Clean the outside of the housing with isopropyl alcohol. Dry the housing with a clean cloth.
4. If installed, remove the bolts that secure the end plates to the housing. Remove the end plates and linings.
5. Remove the pistons from the side of the housing opposite the mounting plate according to the following procedure.
 - a. Use a C-clamp to hold a 12.7 mm (0.5 in) block of wood against two pistons on the mounting side of the housing. Ensure the C-clamp is not in the area in front of the piston bore (Figure 8-14).

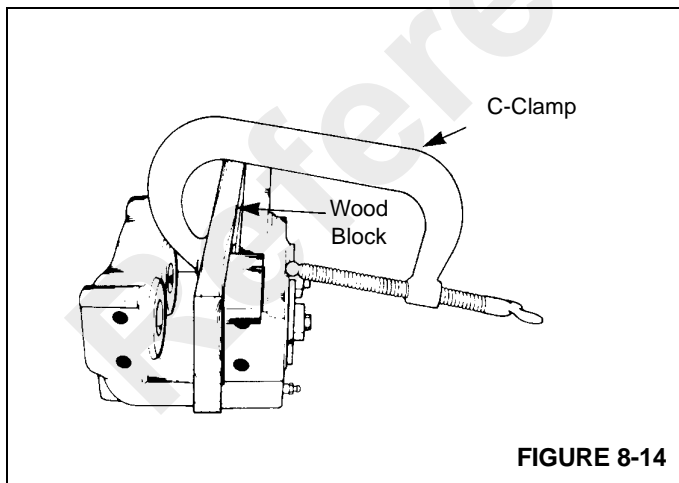
**DANGER**

Do not place hand in front of pistons when forcing them out. Serious personal injury may occur.

- b. Apply compressed air to the inlet fitting to force the pistons out of the other housing. If one piston comes out before the other piston, put a piece of wood in front of the piston that comes out first. Apply compressed air to force the other piston out of the housing (Figure 8-15).

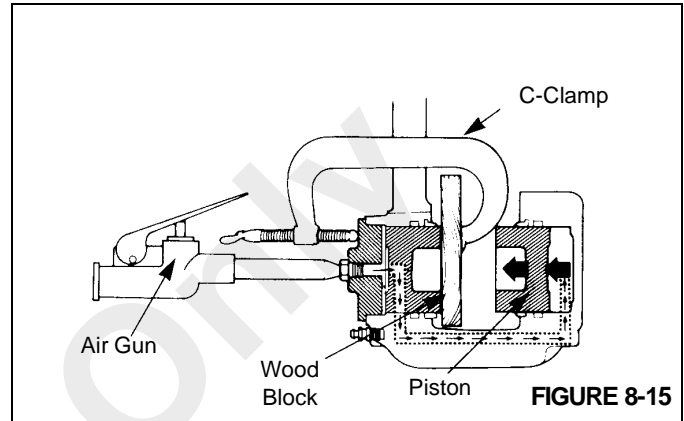

- c. Remove the wood block and the C-clamp from the housing.
 - d. Remove the pistons from the bores that are opposite from the mounting plate.
6. Remove the two bleeder screws from the housing.
 7. Remove the cylinder caps from the housing using an open end wrench. Remove and discard the O-rings (Figure 8-16).

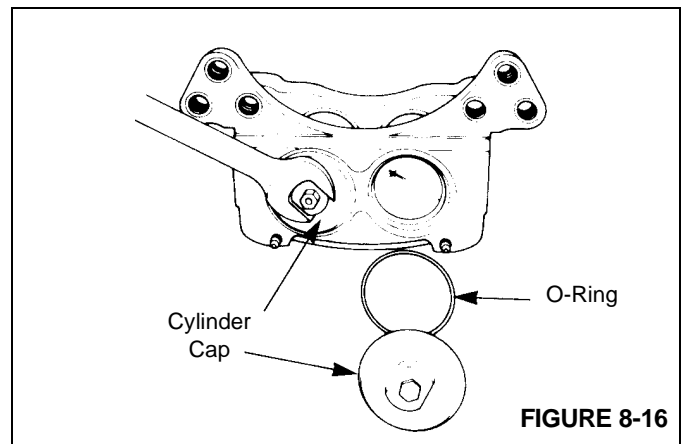

8. Remove the pistons from the mounting plate side of the housing. Push on the ends of the pistons to force them out of the disc side of the housing (Figure 8-17).

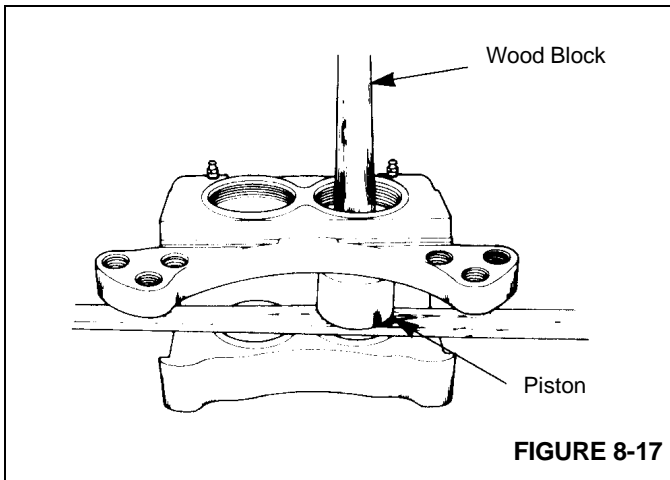

9. Remove the dust seals from the housing.
10. Remove and discard the O-ring and the backup rings (Figure 8-18).

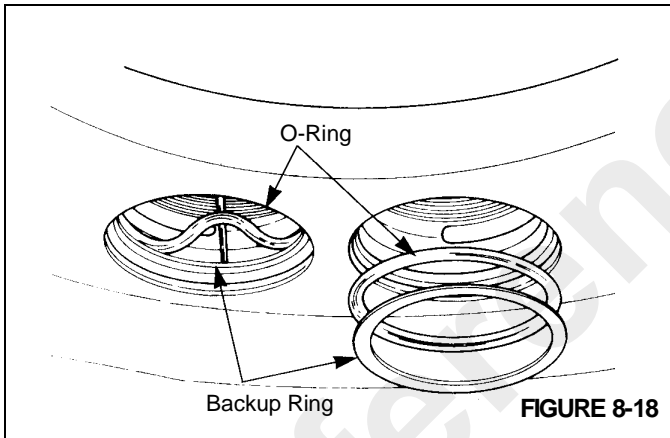

11. Inspect the ring grooves in the housing for scratches and rust. Remove small scratches and rust with emery cloth. Replace the housing if there are large scratches or large amounts of rust. Refer to Inspection - Caliper Parts.
12. Inspect the pistons and the bores for scratches and rust. Remove small scratches and rust with emery cloth. Replace the components if they are worn or if there are large scratches or large amounts of rust. Refer to Inspection - Caliper Parts.

Inspection

Periodic On-Vehicle

Inspect the caliper, linings, and disc for any damage.

Shoes, Linings, and End Plates

Remove the shoes and linings. To help prevent abnormal lining wear, replace worn, bent, or cracked end plates and distorted backing plates. Inspect end plate bolts for wear. Replace the bolts if worn. Inspect the linings for:

- Lining Wear. Replace the linings when the thickness of the lining is less than 3.2 mm (0.125 in) from the back plate (Figure 8-19).
- Lining Wear Not Even. Replace the linings if the thickness of the two linings is significantly different. Check the pistons for correct operation. Replace the piston and/or housing if a piston is cocked in the bore. Check that the disc surface is flat and parallel to the linings (Figure 8-19).

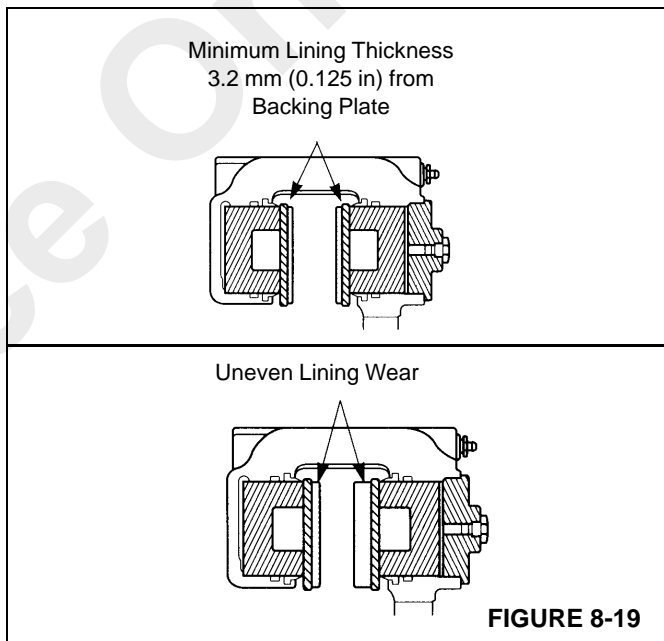

- Oil or Grease on Linings. Replace the linings.
- Cracks on Linings. Replace linings that have large or deep cracks.

NOTE: Small, tight cracks on the surface of the lining are normal when the caliper is used under high temperature conditions.

Caliper for Leaks

Inspect the following areas for fluid leaks (Figure 8-20).

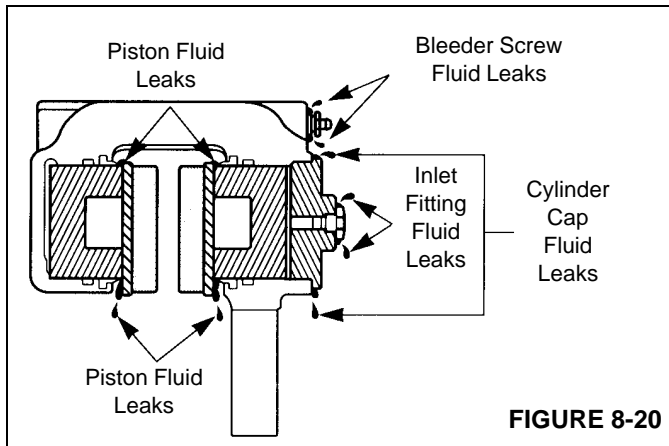

FIGURE 8-20

- **Pistons.** If fluid leaks at a piston, disassemble the caliper. Inspect the piston, the bore, the o-rings, and back-up rings. Service as necessary.
- **Cylinder Cap.** If fluid leaks at a cylinder cap, tighten the cylinder cap, the inlet fitting, and the plug. If the leak continues, disassemble the caliper. Inspect the cylinder cap threads, the housing threads, and the o-ring. Service as necessary.
- **Bleeder Screw.** If fluid leaks at the bleeder screw, tighten the bleeder screw. If the leak continues, replace the bleeder screw.
- **Inlet Fitting.** If fluid leaks at the inlet fitting, tighten the fitting. If the leak continues, replace the o-ring.

Dust Seals

Ensure the dust seals are soft and flexible. Disassemble the caliper and replace dust seals that are hard or damaged.

Disc

If the disc is worn beyond the wear limits, replace the disc (Figure 8-21).

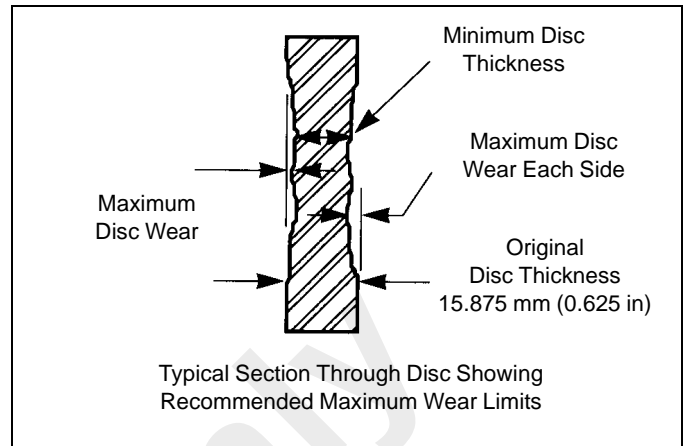

Typical Section Through Disc Showing Recommended Maximum Wear Limits

Lining Backing Plate Thickness	Maximum Disc Wear Each Side	Minimum Disc Thickness
7.1 mm (0.28 in)	1.5 mm (0.06 in)	12.7 mm (0.50 in)
8.6 mm (0.34 in)	2.3 mm (0.09 in)	11.2 mm (0.44 in)

FIGURE 8-21

Caliper Parts

1. Inspect the pistons, housing bores, and o-ring grooves for scratches or corrosion. Remove small scratches or corrosion with fine emery cloth. Replace the components if they are worn beyond wear limits or if there are large scratches or large amount of corrosion.
2. Measure the diameter of the piston. Replace the piston if the outer diameter is worn less than 76.073 mm (2.995 in) (Figure 8-22).

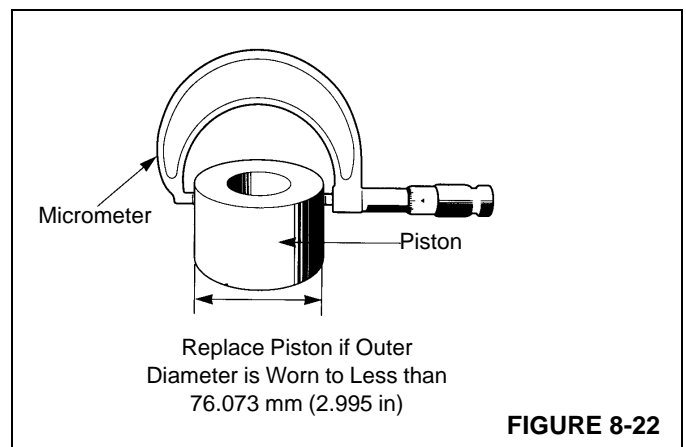

Replace Piston if Outer Diameter is Worn to Less than 76.073 mm (2.995 in)

FIGURE 8-22

3. Measure the diameter of the housing bore. Replace the housing if the diameter is worn to more than 76.276 mm (3.003 in) (Figure 8-23).

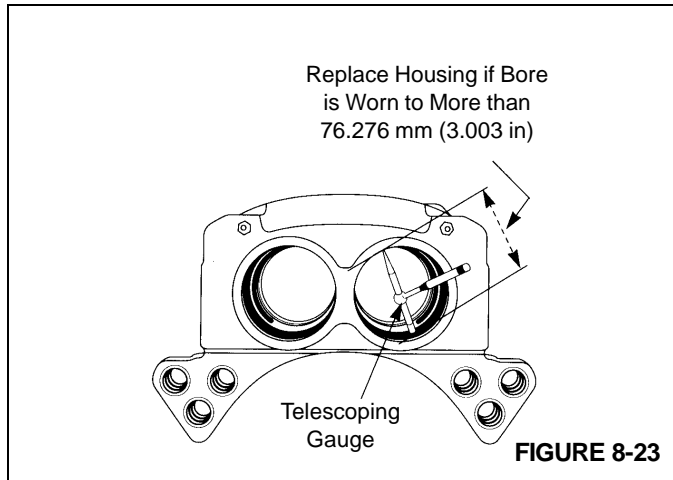

4. Inspect the linings as described previously.
5. Inspect the threads of the caliper, cylinder caps, and all fittings. Replace any component that has thread damage that cannot be repaired.
6. Discard all back-up rings, o-rings, and dust seals. Use new ones when assembling the caliper.

Cleaning



DANGER

Use of cleaning solvents, hot solution tanks, or alkaline solutions incorrectly, can cause serious personal injury. To prevent serious personal injury, follow the instructions supplied by the manufacturer of these products. Do not use gasoline to clean parts. Gasoline can explode and cause serious personal injury.

CAUTION

Use only solvent cleaners to clean ground or polished metal parts. Hot solution tanks or water and alkaline solutions will damage these Parts. Isopropyl alcohol, kerosene, or diesel fuel can be used for this purpose.

- Use solvent cleaners to clean all metal parts that have ground or polished surfaces. Examples of ground or polished parts are the piston and the piston bore in the caliper.
- Metal parts with rough surfaces can be cleaned with solvent cleaners or with alkaline solutions.

- Use a wire brush to clean the threads of fasteners and fittings.
- Use soap and water to clean parts that are not made of metal.
- Scrape away build-ups of mud and dirt on the linings. Replace all linings contaminated with oil or grease.
- Immediately after cleaning, dry all parts with clean paper or rags.

Corrosion Protection

Apply brake system fluid to the cleaned and dried parts that are not damaged and are to be immediately assembled. **Do Not** apply fluid to the brake linings or the disc.

If parts are to be stored, apply a special material that prevents corrosion to all surfaces. **Do Not** apply the material to the brake linings or the disc. Store the parts inside special paper or other material that prevents corrosion.

Assembly

Caliper

CAUTION

Use only specified components when assembling the calipers. Do not mix components from other calipers. Installing the wrong components may cause the caliper not to operate correctly and may cause damage to equipment. Use of non manufacturer's parts can cause damage, loss of braking, and serious personal injury.

NOTE: The o-rings, back-up rings, pistons, and bores must be lubricated before installing the pistons.

1. Lubricate all pistons, bores, o-rings, and back-up rings with silicone grease. If silicone grease is not available, use the same type of fluid that is used in the brake system.
2. Install new o-ring and a new back-up ring in the groove in the middle of the bore. The o-ring is installed toward the outboard end of the bore. The back-up ring is installed toward the lining side of the bore (Figure 8-16).

CAUTION

Do not use silicone grease on the dust seal.

3. Install a new dust seal in the top groove of the bore (Figure 8-24).

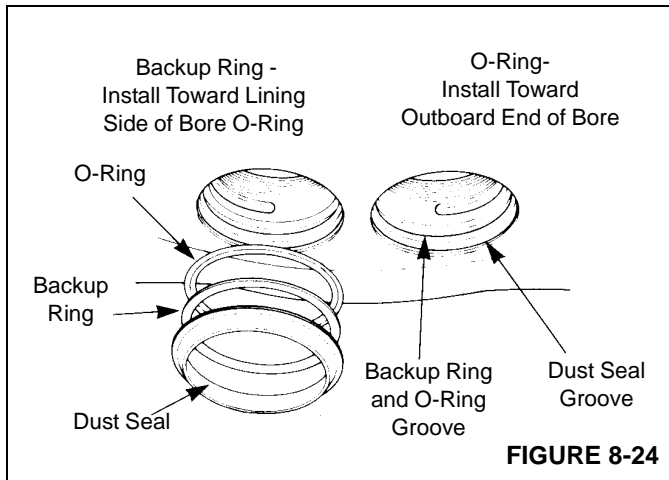

FIGURE 8-24

4. Install the pistons in the housing. Push the pistons in from the lining side of the housing. Ensure the pistons are straight in the bores. Push each piston into the bore until the top of the piston is even with the top of the dust seal (Figure 8-25).

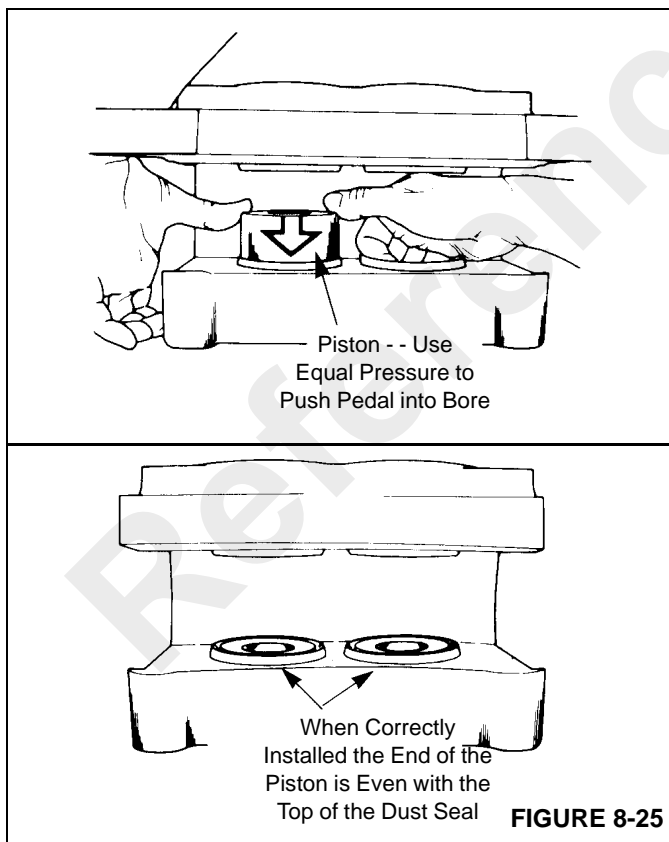

FIGURE 8-25

5. Install a new o-ring in the groove of the cylinder cap. Ensure the o-ring is not cut by the threads on the cylinder cap.

NOTE: Apply extra grease on o-ring before installing cylinder caps. this will keep o-ring from catching on threads as cylinder cap is threaded into housing.

6. Install the cylinder caps in the caliper housing. Tighten the cylinder caps to 102 Nm (75 lb-ft) minimum as shown in (Figure 8-26).

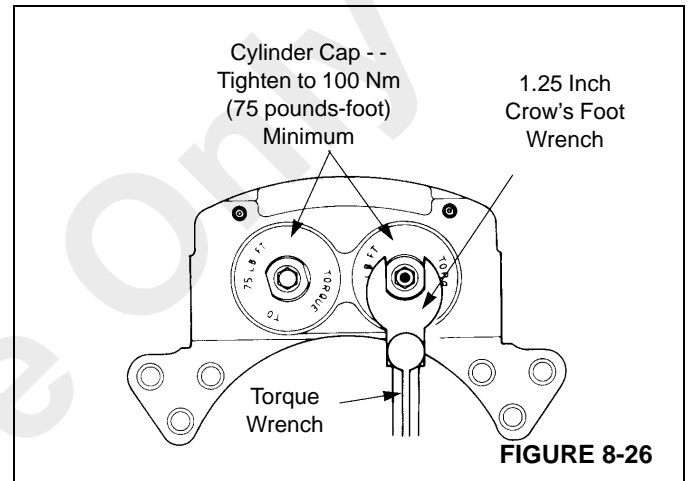

FIGURE 8-26

7. Install the bleeder screws in the housing. Tighten to 11.3 to 13.6 Nm (100 to 120 lb-in).

8. Install the o-ring and the inlet fitting in the cylinder cap.

Installation

Linings

CAUTION

Always replace both linings. If only one lining is replaced, possible disc damage can occur.

1. Install the linings in the caliper housing.
2. Position the end plates on the housing and secure with bolts. Apply Loctite 271 or equivalent to the bolt threads. Tighten the bolts to 224 to 285 Nm (165 to 210 lb-ft).
3. Ensure the linings move freely in the housing.
4. Bleed the brake system.
5. Apply and release the brakes three times to ensure the caliper operates correctly. Check for fluid leaks. Ensure the linings move freely.

Caliper

1. Position the caliper housing on the mounting bracket. If shims where used, place them as marker during removal.
2. Secure the caliper housing with the bolts and tighten them to 678 to 813 Nm (500 to 600 lb-ft).
3. Install the linings. Refer to INSTALLATION - Linings.
4. Ensure the housing is installed correctly on the mounting bracket. The disc must be within ± 1.5 mm (± 0.06 in) of being centered between the lining end plates.
 - a. To increase outboard clearance and decrease inboard clearance, install a shim either between the housing and mounting bracket or between the hub and disc.
 - b. The shims must be steel, ground flat, and parallel and must cover the entire mounting surface of the hub or housing. The linings must move freely in the housing and between the end plates (Figure 8-27).

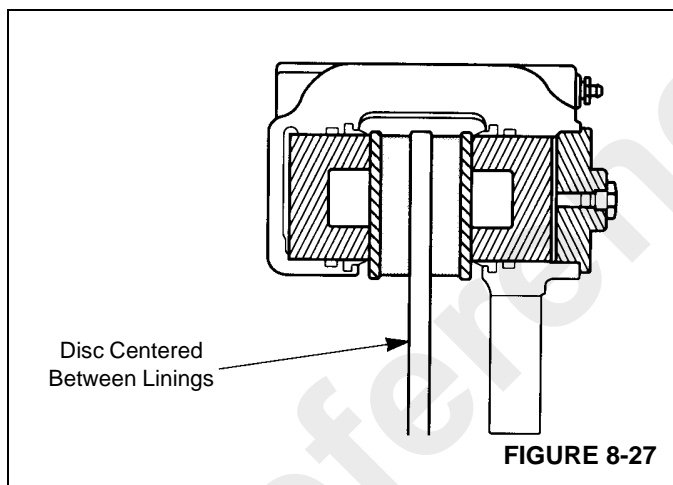

5. Connect the hydraulic brake line to the inlet fitting.
6. Bleed the brake system.
7. Apply and release the brakes three times to ensure the caliper operates correctly. Check for fluid leaks. Ensure the linings move freely.

PARKING BRAKE ACTUATOR

Description

The spring-applied, hydraulically-released parking brake actuator is located on the transmission and is used to apply and release the parking brake.

Maintenance

Removal

1. Chock the wheels to prevent crane movement.

CAUTION

Do not exceed 1861.5 kPa/18.6 bar (270 psi) hydraulic pressure to avoid damage to the brake. 1172.1kPa/11 bar (170 psi) is required to fully release the brake.

2. Start the engine, ensure the transmission is in neutral, and position the Park Brake switch to Off. This will pressurize the brake actuator to release the tension on the brake linkage. Engine must remain running.
3. Remove the capscrews securing actuator to the brake caliper. Slide the actuator off the actuator rod.
4. Position the Park Brake switch to On (press top of switch) and shut down the engine.
5. Disconnect the hydraulic line from the brake actuator, then cap or plug all openings.

Installation

NOTE: Mount brake so that the linings are parallel with the disc within 0.381 mm (0.015 in). Disc is to be located the proper distance from the mounting surface per assembly drawing.

1. Slide brake over disc and into mounting position.
2. Start hex mounting bolts into mounting surface far enough to just support the brake.
3. Remove plug, loosen the coupling nut and then tighten socket setscrew until linings are clamped to the disc. This locates and holds the brake in the proper position to set the hex mounting bolts and hex nuts.
4. Tighten hex mounting bolts until they make contact with the urethane springs, then tighten 4 flats approximately 1.778 mm (0.07 in) more. This puts the proper amount of pre-load on the urethane springs.
5. Tighten jam nut/sleeves against mounting surface and torque 271 Nm (200 lb-ft).

CAUTION

Brake linings are susceptible to contamination. When installing or servicing brakes, keep all oil and fluids away from linings. Poor brake performance may result if linings are contaminated.

6. Attach brake line to inlet port located on top of the hydraulic cylinder.
 7. Apply hydraulic pressure to the brake.
 8. With plug removed, loosen coupling nut and set running clearance to 0.5 to 0.7 mm (0.020 to 0.030 in) total by adjusting the socket setscrew. Torque the coupling nut while holding the socket setscrew in position. Torque nut 68 to 75 Nm (50 to 55 lb-ft).
 9. Replace plug. Torque plug 61 to 68 Nm (45 to 50 lb-ft).
 10. Even up running clearance to 0.25 to 0.3 mm (0.010 to 0.015 in) each side by adjusting the socket head capscrew.
- NOTE:** Re-adjust the brake when running clearance reaches a total of 2.54 mm (0.100 in).
11. Position the Park Brake switch to On (press top of switch) and shut down the engine.

Adjustment

1. Chock the wheels to prevent crane movement.

CAUTION

Do not exceed 1861.5 kPa/18.6 bar (270 psi) hydraulic pressure to avoid damage to the brake. 1172.1kPa/11 bar (170 psi) is required to fully release the brake.

2. Start the engine, ensure the transmission is in neutral, and position the Park Brake switch to Off (press bottom of switch). This will pressurize the brake actuator to release the tension on the brake linkage. Air pressure of 1862 kPa (270 psi) may be used to pressurize the actuator. Screw the caging nut up under the actuator chamber.
3. Install the rod ball joint until the ball joint will just connect to the brake linkage with the brake lever in a horizontal position.
4. Lock the rod ball joint with the jam nut and back off the caging nut.
5. Position the Park Brake switch to On (press top of switch) and shut down the engine.

PARKING BRAKE

Description

The parking brake is mounted on the transmission. The brake is a disc-type brake that is controlled by a switch on

the front console in the cab and is spring-applied and hydraulically released by an actuator.

Maintenance

Removal

1. Chock the wheels to prevent crane movement.

CAUTION

Do not exceed 1861.5 kPa/18.6 bar (270 psi) hydraulic pressure to avoid damage to the brake. 1172.1kPa/11 bar (170 psi) is required to fully release the brake.

2. Start the engine, ensure the transmission is in neutral, and position the Park Brake switch to Off (press bottom of switch). This will pressurize the brake actuator to release the tension on the brake linkage. Air pressure of 1862 kPa (270 psi) may be used to pressurize the actuator. Screw the caging nut up under the actuator chamber.
3. Position the Park Brake switch to On (press top of switch) and shut down the engine.
4. Tag and disconnect the hydraulic hose from the actuator. Cap or plug all openings.
5. Unthread the two mounting bolts securing the brake assembly to the mounting bracket, then carefully remove the brake assembly from the mounting bracket and the brake disc.

Installation

1. Position the brake over the disc and align mounting bracket holes.
2. Thread the mounting bolts into the mounting bracket until the caliper is centered over the brake disc.
3. Torque the jam nuts to 136 to 163 Nm (100 to 120 lb-ft) against the mounting bracket.
4. Connect the hydraulic hose to the actuator.
5. Start the engine, ensure the transmission is in neutral, and position the Park Brake switch to Off (press bottom of switch). This will pressurize the brake actuator to release the spring tension. Unscrew the caging nut from under the actuator chamber.
6. Position the Park Brake switch to On (press top of switch) and shut down the engine.

Procedure for Manually Releasing the Parking Brake

NOTE: Refer to (Figure 8-28) and (Figure 8-30) during parking brake adjustment procedure.

1. Block wheels to prevent crane from moving.
2. Remove the screw-in plug (1).
3. Loosen coupling nut (3).
4. Back out socket setscrew (2) until brake is released.



6857-1

FIGURE 8-28

5. While holding the socket setscrew (2), tighten the coupling nut (3).
6. Reinstall the screw-in plug (1).

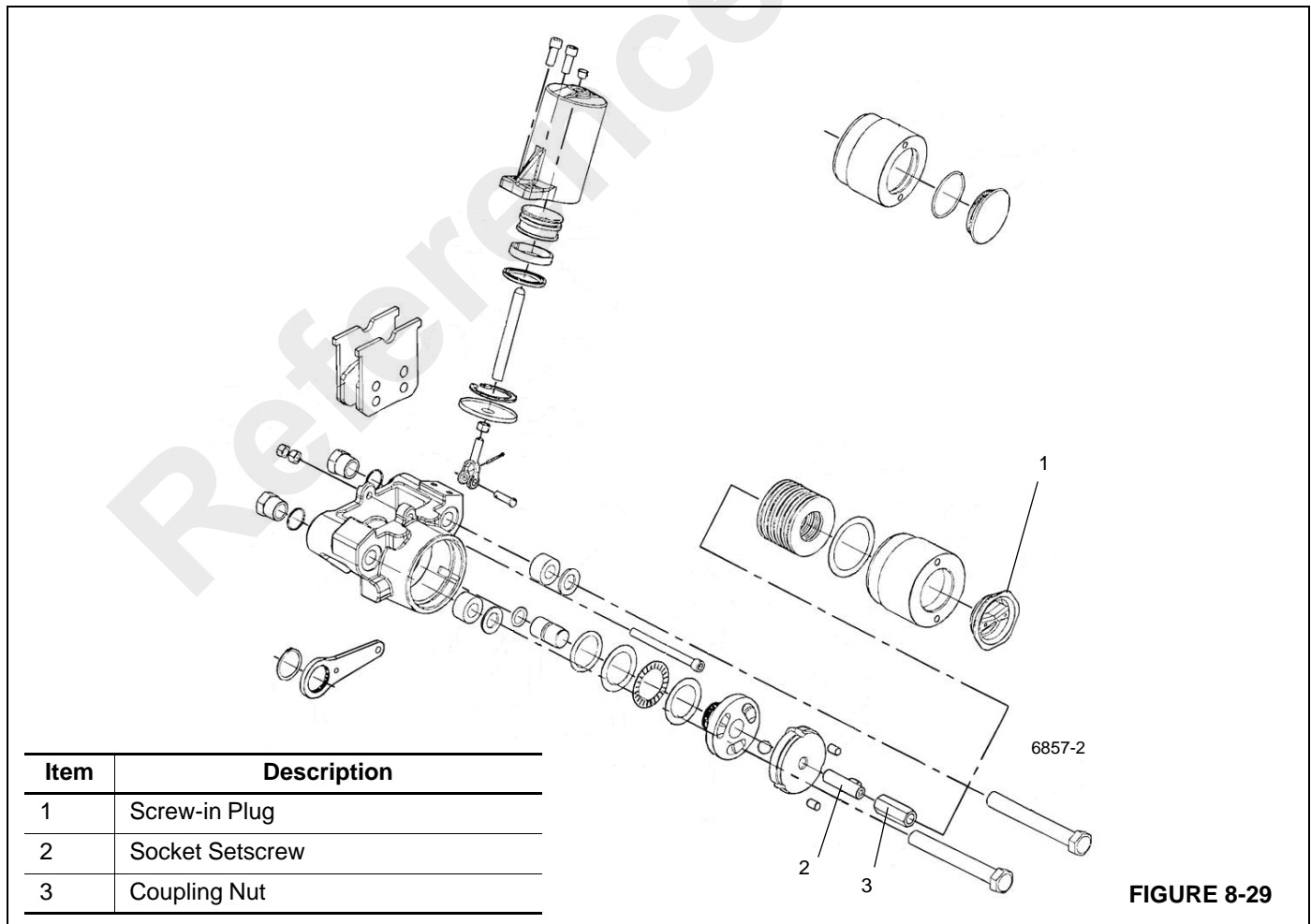

Item	Description
1	Screw-in Plug
2	Socket Setscrew
3	Coupling Nut

FIGURE 8-29

PARK BRAKE VALVE

Description

The range shift/parking brake valve controls the flow of oil to the parking brake, hi-low range and axle disconnect actuators by the use of two solenoid valves. The valve is located on the center of the frame. Pressure is supplied to the valve from the transmission charge pump.

The parking brake solenoid valve is a two position three-way valve. In its de-energized position, the inlet port is blocked and the parking brake actuator is drained to the reservoir. When the solenoid is energized, the reservoir port is blocked and pressurized oil is directed to the actuator, engaging the parking brake.

The range shift solenoid valve is a two position four-way valve. In its de-energized position, pressurized oil flows to the "B" port of the range shift actuator, while the "A" port is drained to the reservoir along with the axle disconnect actuator for two wheel drive/high range. When the solenoid is energized, pressurized oil is directed to the "A" port of the range shift actuator and the axle disconnect actuator while port "B" of the range shift actuator is drained to the reservoir for four wheel drive/low range.

Removal

1. Tag and disconnect the electrical connectors to the valve.
2. Tag and disconnect the hydraulic hoses from the valve. Cap or plug the lines and ports.
3. Remove the capscrews, lockwashers, flatwashers and nuts securing the valve to the frame. Remove the valve.

Installation

1. Secure the valve to the frame with the nuts, flatwashers, lockwashers and capscrews. Torque the capscrews 25 to 27 Nm (18 to 20 lb-ft).
2. Connect the hydraulic hoses to the ports on the valve as tagged during removal.
3. Connect the electrical connectors to the valve as tagged during removal.

Functional Tests

1. Start and idle engine.
2. With units on outriggers, check for proper two/four wheel operation.

NOTE: For further information on the park brake valve, refer to Section 2 - HYDRAULIC and PRESSURE SETTINGS.

OUTRIGGERS

Outrigger Circuit

The outrigger circuit consists of four extension cylinders, four jack cylinders, an integrated outrigger/rear steer valve, front and rear outrigger control manifolds, pilot operated check valves and four Outrigger Monitoring System (OMS) (Optional—Standard in North America) string potentiometers. The front two extension cylinders are mounted in the front outrigger beams and the rear two extension cylinders are mounted in the rear outrigger beams. The front and rear outrigger beams are mounted in their respective outrigger boxes; in turn a jack cylinder is mounted on the end of each outrigger beam. The integrated outrigger/rear steer valve is mounted on the front face of the carrier frame front cross member. The front and rear outrigger control manifolds are mounted on the inside center of their respective outrigger box. An OMS string potentiometer (if equipped) is mounted inside each outrigger box. The potentiometer is connected by a cable to the outrigger beam to monitor the beam's horizontal position—fully retracted, mid-extend, or full extended.

The outrigger selector controls are located in the cab on the CCS display or jog dial. Both the integrated outrigger valve and the manifold solenoid valves are electrically actuated from these controls. The solenoid switches must be depressed and held to actuate the solenoid valves. The integrated outrigger valve switch is spring loaded to the off position. The console is placarded with switch positions.

A sight bubble level is mounted on the right side of the cab. The sight bubble level provides the operator with a visual indication of crane level attitude.

Theory of Operation

NOTE: Refer to Section 3 - OPERATING CONTROLS and PROCEDURES in the Operator Manual for operation of the outrigger switches.

Maintenance

Troubleshooting

Symptom	Probable Cause	Solution
1. Slow or erratic operation of outrigger extension cylinders.	a. Damaged relief valve.	a. Remove relief valve; clean or replace.
	b. Low hydraulic oil.	b. Replenish oil to proper level. Refer to LUBRICATION (pg 9-1)
	c. Sticking solenoid valve spool.	c. Repair or replace valve spool.
	d. Improper ground to base of solenoid.	d. Ground properly.
	e. Damaged O-rings and swivel	e. Remove swivel and replace O-rings.
	f. Directional selector switch sticking.	f. Clean or replace switch.
	g. Collector ring dirty or glazed.	g. Clean and deglaze collector ring.
	h. Damaged wiring to solenoid.	h. Replace wiring.
	i. Weak brush springs on collector ring.	i. Replace brush springs.
	j. Damaged extension cylinder (internal parts).	j. Remove extension cylinder and repair as necessary.
	k. Bent cylinder rods.	k. Replace piston rods and seals.
	l. Excessive material on outrigger beams.	l. Clean outrigger beams.
	m. Binding outrigger beam.	m. Repair or replace outrigger beam.
	n. Damaged outrigger valve.	n. Repair or replace valve.
o. Damaged valve coil.	o. Replace coil.	
p. Main hydraulic pump cavitation.	p. Replace or tighten hose or fitting.	

Symptom	Probable Cause	Solution
Slow or erratic operation of outrigger extension cylinders. (continued)	q. Partially shifted hydraulic spool in selector valve or manifolds.	q. Disassemble, clean, and polish spool and valve housing with very fine emery cloth (water paper).
	r. Insufficient voltage for operation of solenoid valve.	r. Solenoids require a minimum of 9.5 volts to energize. Check outrigger wiring and electrical coupling collector rings.
	s. Damaged piston seals.	s. Replace all cylinder seals.
	t. Worn or damaged hydraulic pump section.	t. Repair or replace pump section.
	u. Scored cylinder barrel.	u. Repair or replace extension cylinder.
	v. Cracked or damaged piston.	v. Replace rod weld and all cylinder seals.
	w. Piston loose on piston rod.	w. Replace all cylinder seals and torque piston locknut.
2. Sticking spool.	a. Dirt in the system.	a. Change oil and flush system.
	b. Distortion caused by tie bolts being overtorqued.	b. Retorque tie bolts.
	c. Flow in excess of valve rating.	c. Limit flow through valve to that recommended. Check pump output and cylinder ratio.
	d. Pressure in excess of valve rating.	d. Check relief valve setting or pump compensation with that recommended.
	e. Electrical failure.	e. Check wiring and solenoids.
3. External leakage.	a. Damaged O-ring or quad rings.	a. Check for chipped packings and replace.
	b. Loose tie bolts.	b. Retorque tie bolts.
	c. Damaged solenoid.	c. Replace damaged parts.
4. Solenoid failure.	a. No current.	a. Check power source of at least 85% of coil rating.
	b. Damaged solenoid assembly.	b. Replace solenoid.
	c. Short in solenoid.	c. Replace coil.
	d. Loss of solenoid force.	d. Decrease time of solenoid energization, decrease cycle rate.

Symptom	Probable Cause	Solution
5. Outrigger jack cylinder slow or erratic.	a. Low in hydraulic oil.	a. Replenish oil to proper level.
	b. Damaged main relief valve.	b. Repair or replace valve.
	c. Damaged holding valve seals.	c. Replace holding valve seals.
	d. Bent cylinder rod.	d. Replace cylinder rod and seals.
	e. Bent outrigger housing.	e. Repair or replace outrigger housing.
	f. Excessive material on beams.	f. Clean outrigger beams.
	g. Sticking solenoid valve spool.	g. Repair or replace valve spool.
	h. Damaged wiring to solenoid.	h. Repair or replace wiring.
	i. Weak brush springs on collector rings.	i. Replace brush springs.
	j. Collector ring dirty or glazed.	j. Clean or deglaze collector ring.
	k. Directional selector switch sticking.	k. Clean or replace switch.
	l. Main hydraulic pump cavitation.	l. Replace or tighten hose and fittings.
	m. Worn or damaged hydraulic pump section.	m. Repair or replace pump section.
6. Outrigger jack cylinder retracts under load.	a. Damaged piston seals.	a. Replace all cylinder seals.
	b. Damaged holding valve seals.	b. Replace seals.
	c. Damaged holding valve.	c. Replace valve assembly.
	d. Scored cylinder barrel.	d. Repair or replace cylinder.
	e. Cracked or damaged piston.	e. Replace piston and all cylinder seals.
7. Outrigger jack cylinder extends while machine is traveling.	a. Damaged piston seals.	a. Replace all cylinder seals.
	b. Scored cylinder barrel.	b. Replace jack cylinder.
	c. Cracked or damaged piston.	c. Replace piston and seals.
	d. Piston loose on cylinder rod.	d. Replace seal and retorque.
8. Outrigger system will not activate (from stowed or extended and down position).	a. Hydraulic oil low.	a. Replenish system.
	b. Loose or broken wire on switch.	b. Repair or replace wiring.
	c. Clogged, broken, or loose lines or fittings.	c. Clean, tighten, or replace lines or fittings.
	d. Damaged relief valve or damaged control valve.	d. Repair or replace valve.

Symptom	Probable Cause	Solution
9. Outrigger system activates, but selected outrigger will not stow or extend and lower as desired.	a. Clogged, broken, or loose hydraulic lines or fittings.	a. Clean, tighten, or replace lines or fittings.
	b. Loose or broken wire on control switch or solenoid valve.	b. Repair or replace wiring.
	c. Damaged solenoid valve.	c. Repair or replace valve.
	d. Damaged control switch.	d. Replace switch.
	e. Damaged hydraulic cylinder.	e. Repair or replace cylinder.
10. Outriggers will not set.	a. Improper sequence of activation.	a. Activate individual control switch; then activate system control switch.
11. Two outriggers activate from single control switch.	a. Damaged solenoid valves.	a. Repair or replace.
12. The two outriggers will not stow.	a. Hydraulic lock.	a. Recycle individual outrigger(s).
13. Individual outrigger will not set or stow.	a. Damaged piston seals.	a. Replace seals.
	b. Damaged check valve.	b. Repair or replace valve.
	c. Loosen or broken wire on control switch or solenoid valve.	c. Repair or replace wiring.
	d. Damaged solenoid valve.	d. Repair or replace valve.

Outrigger Beam

Description

The outrigger beam assembly (Figure 8-30) consists of an outrigger beam, a jack cylinder, a extension cylinder, and the required hoses and mounting hardware.

Theory of Operation

When the outrigger extension is activated, it extends or retracts the outrigger beam within the outrigger box. The outrigger beam can be extended to the mid-extend position by allowing the lock pin to ride on the top of the beam while it's extending. The lock pin will automatically drop into the hole when the beam reaches the mid-extend position.

The jack cylinder is mounted to the end of the beam and applies force to the outrigger beam vertically. This sequence of events provides for lifting and stabilizing the crane for operation.

Maintenance

Removal

1. On the jack cylinder end of the beam, remove the set screw from the side adjustable wear pad and back off the wear pad from the outrigger box.
2. Remove the cover from the opposite end of the outrigger box. Remove the setscrew from the side adjustable wear pad and back off the wear pad from the beam.
3. Remove the setscrews from the bottom adjustable wear pads and back off the wear pads leaving approximately 6 mm (0.23 in) protruding
4. Extend the outrigger slightly to facilitate attaching a lifting device to the outrigger beam.



DANGER

Be sure any blocking material used is capable of supporting the weight of the outrigger beam. Do not allow it to tilt or slide. Failure to do so could result in death or injury to personnel.

5. Place blocking material under the outrigger beam.

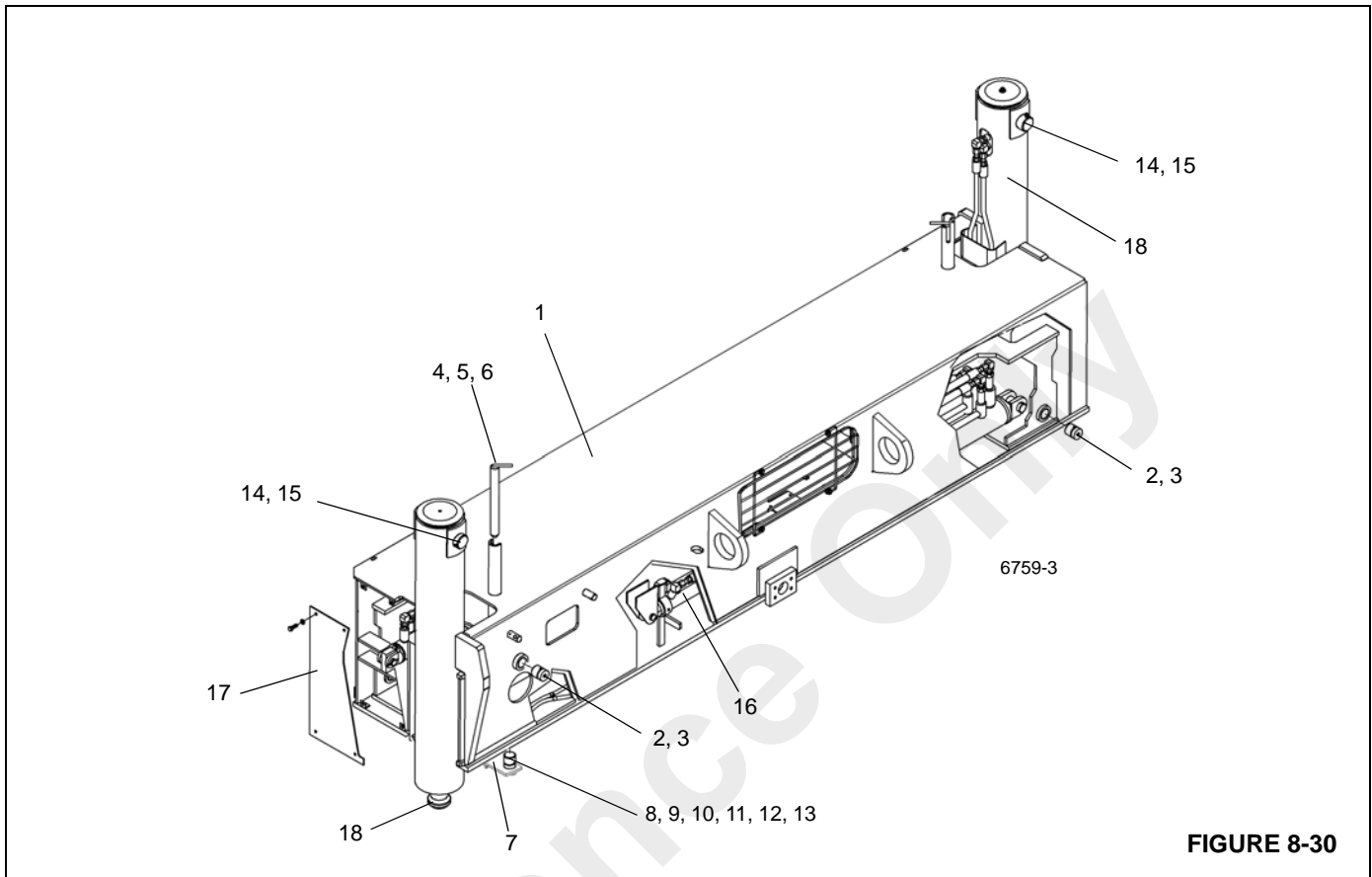

FIGURE 8-30

Item	Description
1	Outrigger Box Assembly
2	Hex Nut
3	Capscrew
4	Pin
5	Hex Nut
6	Capscrew
7	Adjusting Plate
8	Hex Nut
9	Setscrew

Item	Description
10	Capscrew
11	Plate
12	Wear Pad
13	Flatwasher
14	Cotter Pin
15	Clevis Pin
16	Extension Cylinder
17	Cover
18	Jack Cylinder

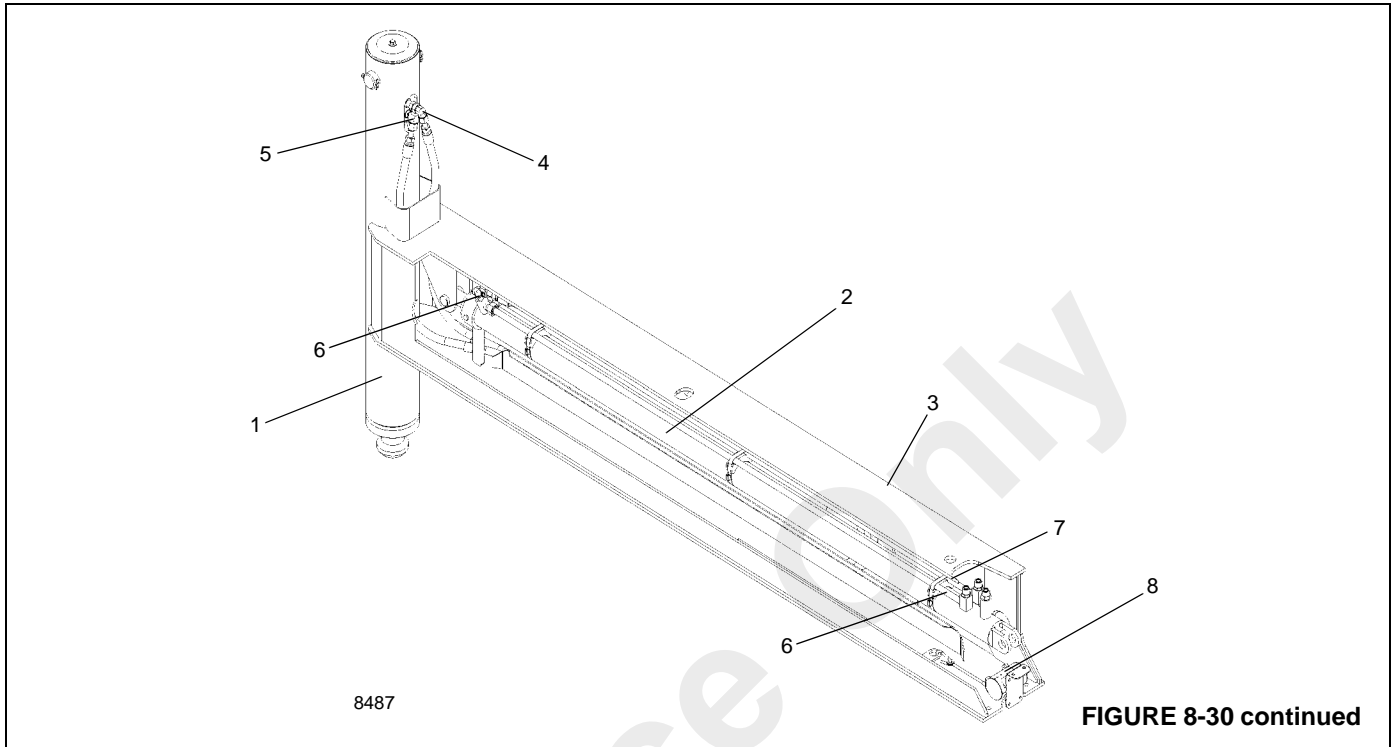
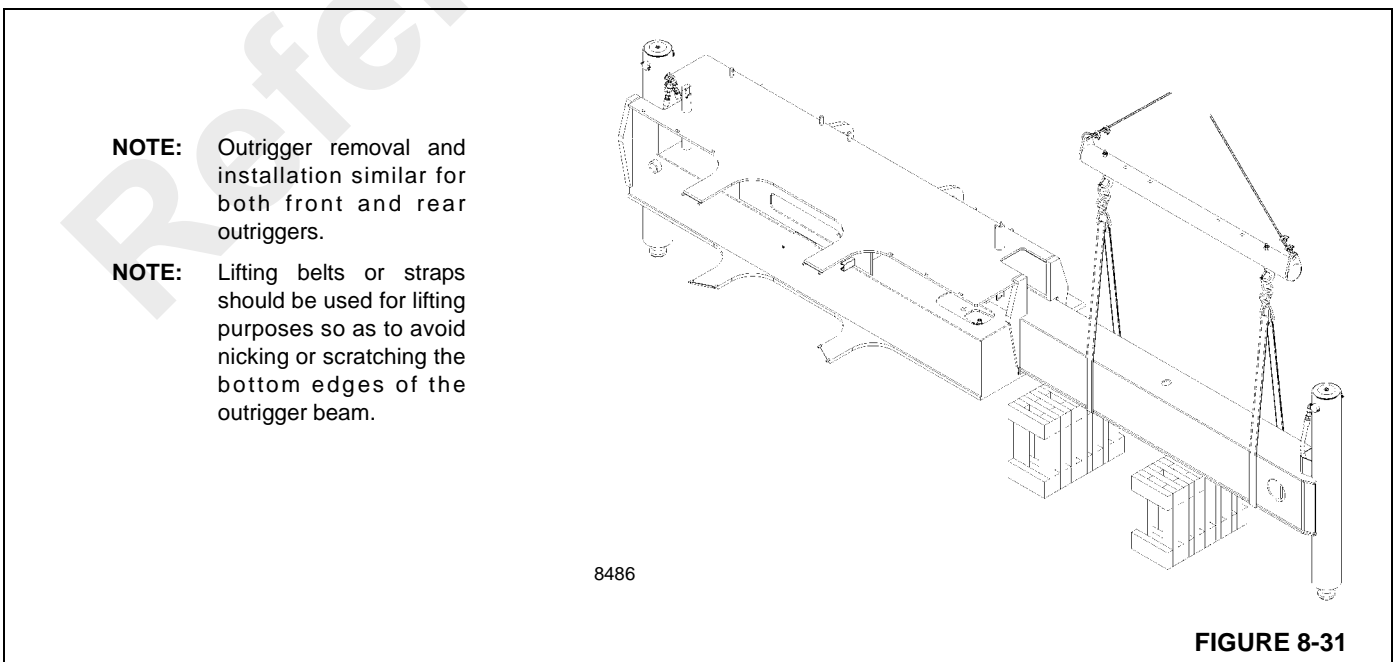

FIGURE 8-30 continued

Item	Description
1	Jack Cylinder
2	Extension Cylinder
3	Outrigger Beam
4	Jack Cylinder Extend Port

Item	Description
5	Jack Cylinder Retract Port
6	Extension Cylinder Retract Port
7	Extension Cylinder Extend Port
8	OMS Potentiometer



NOTE: Outrigger removal and installation similar for both front and rear outriggers.

NOTE: Lifting belts or straps should be used for lifting purposes so as to avoid nicking or scratching the bottom edges of the outrigger beam.

FIGURE 8-31

6. Tag and disconnect the hydraulic lines at the cylinder barrel end of the extension cylinder. Cap all lines and fittings.

NOTE: Do not allow the end of the outrigger extension cylinder to fall when the cylinder mounting shaft is removed. Use blocking to limit the drop or an adequate soft support to cushion any distance the rod will drop.

7. Remove the cotter pin and clevis pin securing the cylinder barrel end of the extension cylinder to the outrigger housing. Carefully extend the outrigger beam until the extension cylinder is free of the housing and carefully lay the end of the cylinder on the bottom of the outrigger beam or leave on blocking.
8. After attaching a suitable lifting device of straps or belts (Figure 8-31) instead of chains to prevent nicking the bottom edges of the outrigger beam, pull the outrigger beam out of the outrigger box, re-adjusting the lifting attachment to prevent the extension cylinder from sliding out of the outrigger beam when the beam clears the outrigger box.



DANGER

Be sure any blocking material used is capable of supporting the weight of the outrigger beam. Do not allow it to tilt or slide. Failure to do so could result in death or injury to personnel.

NOTE: The outrigger beam assembly weighs approximately 374 kg (824 lb).

9. Position the outrigger beam on the blocking material.

Inspection

Inspect the outrigger beams for bends, evidence of cracks, or other damage. Check the outrigger beam internally for hydraulic fluid, which may indicate a leaking cylinder, loose connection, or damaged hydraulic line.

Installation

NOTE: Apply anti-seeze compound on clevis pins and setscrews during installation.

1. Apply grease (EPMPG) to the bottom of the outrigger beam.
2. If removed, install the side adjustable wear pad in the outrigger beam.
3. Install the bottom wear pads with approximately 6 mm (0.23 in) protruding. This will prevent the beam side plates from riding on the bottom of the box (Figure 8-32).

4. Attach a suitable lifting device of straps or belts instead of chains to prevent nicking the bottom edges of the outrigger beam.
5. Slide the beam into the outrigger housing and align the cylinder bushing with the mounting hole.
6. Apply anti-seeze compound to the clevis pin. Secure the cylinder barrel to the housing with the clevis pin and cotter pin.

CAUTION

Be sure that the piston side of all outrigger cylinders are connected to the solenoid valve bank. Reversal of port connection of the rod and piston sides could result in severe damage to the cylinders as very high pressure intensification will occur.

CAUTION

During initial start-up and checking of the outrigger operation, each control switch must be operated before operating the selector valve. If hydraulic lines are reversed to one or more cylinders, this will prevent damage to the cylinders.

7. Connect the hydraulic lines as tagged prior to removal.
8. Install the side adjustable wear pad in the outrigger box.
9. Adjust the wear pads, refer to WEAR PAD ADJUSTMENT in this Sub-Section.
10. Install the end cover.

NOTE: At installation, be sure that the outrigger jack cylinder hydraulic hoses are not trapped against the outrigger box when the beam is fully retracted.

Wear Pad Adjustment.

NOTE: When adjusting wear pads, refer to Wear Pad Adjustment (Figure 8-32).

1. Adjust the bottom wear pads until a gap of 3 mm (0.11 in) is obtained between the top of the beam and the top of the outrigger box. Install and lock setscrew against wear pad.
2. Adjust outrigger box side wear pad until a gap of 2 mm (0.07 in) is obtained between beam and shims welded in top and bottom of box. Install and lock set screw against wear pad.
3. Adjust outrigger beam side wear pad until a gap of 2 mm (0.07 in) is obtained between shim welded on beam and side of box. Install and lock set screw against wear pad.

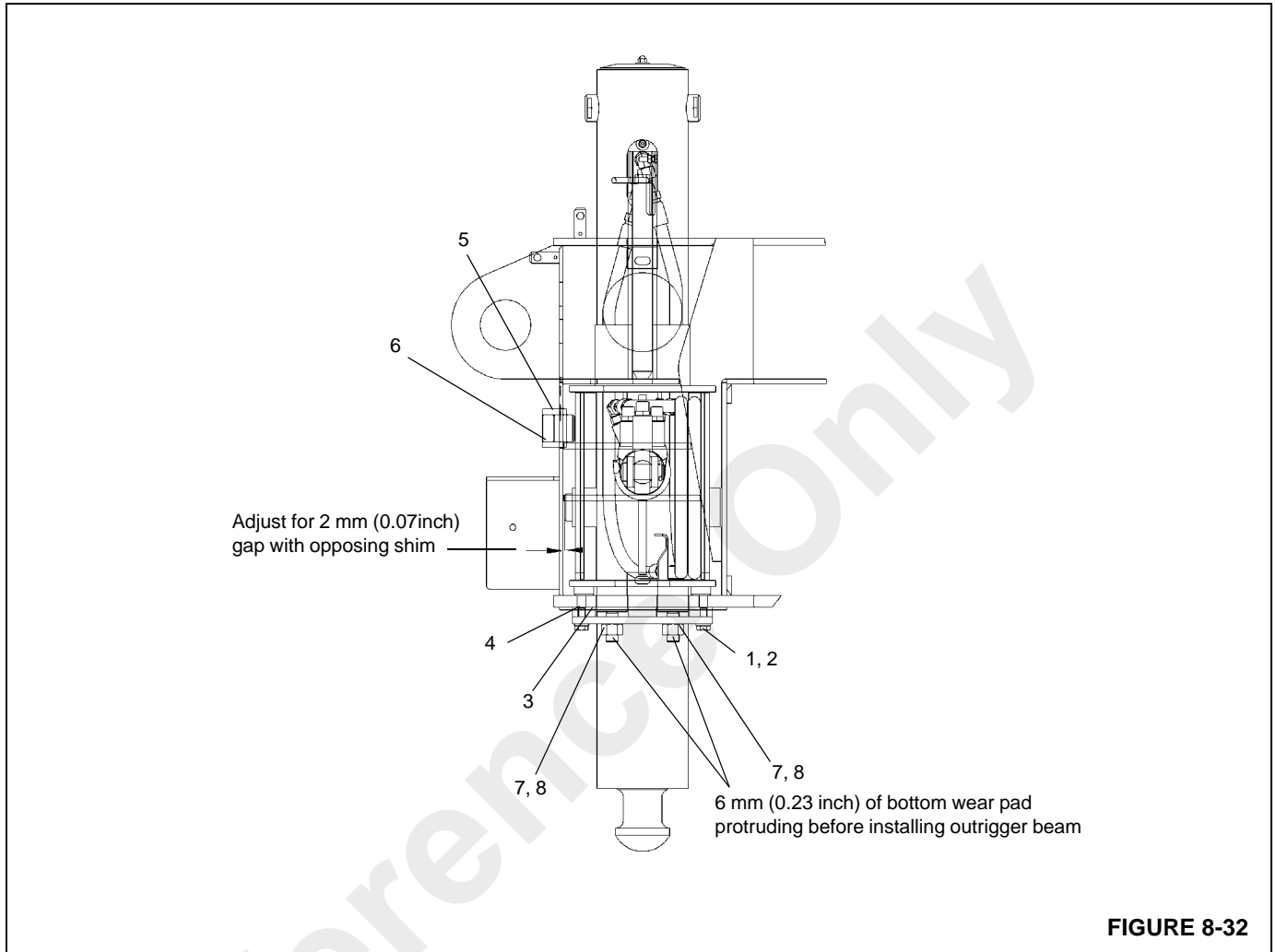

FIGURE 8-32

Item	Description
1	Capscrew
2	Washer
3	Plate
4	Wear Pad
5	Wear Pad
6	Slotted Setscrew
7	Setscrew
8	Hex Nut

Extension Cylinder

Description

Two outrigger extension cylinders are utilized within each outrigger box assembly. The extension cylinders provide the

force for the outrigger beam's horizontal movement. The cylinder weighs approximately 42 kg (92.5 lb).

Maintenance

NOTE: Refer to Cylinders in Section 2 - HYDRAULIC AND PRESSURE SETTINGS for Disassembly and Assembly of the cylinder.

Removal

1. Remove the outrigger beam. Refer to OUTRIGGER BEAM - REMOVAL in this section.
2. Remove the cotter pin and clevis pin securing the rod end of the extension cylinder to the outrigger beam.
3. Pull the extension cylinder from the outrigger beam until the hydraulic hoses on the rod end of the cylinder can be accessed. Tag and disconnect the hoses from the rod end of the cylinder. Cap or plug all openings.
4. Remove the cylinder.

Installation

1. Place the cylinder in the beam.

NOTE: Keep hydraulic fittings and hoses close to angles shown (Figure 8-33) and as low as possible to prevent rubbing with the beam top plate and side plate, and for proper tracking during beam extension and retraction.

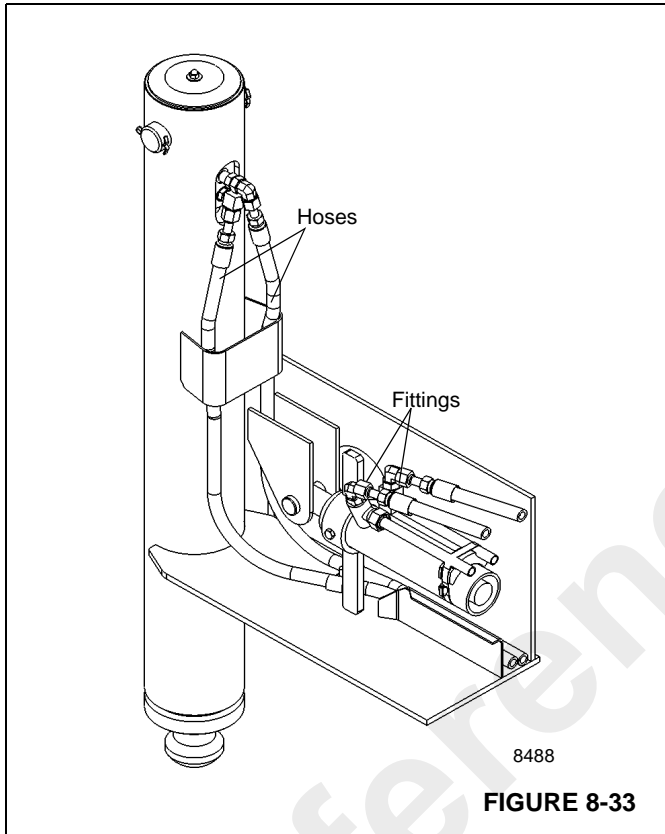

FIGURE 8-33

2. Position the extension cylinder so the hydraulic ports on the rod end of the cylinder can be accessed. Connect the hydraulic hoses to the ports as tagged during removal.
3. Push the cylinder into the outrigger beam. Align the cylinder rod with the clevis in the beam. Apply anti-seeze to the clevis pin and secure in place with the clevis pin and cotter pin.
4. Install the outrigger beam. Refer to **OUTRIGGER BEAM - INSTALLATION** in this section.

Functional Check

1. Activate the hydraulic system; extend and retract the outrigger.
2. Observe the operation of the outrigger beam.
3. Check the hydraulic connections for any evidence of leakage.

Jack Cylinder

Description

Four jack cylinders are used on the crane, one at the end of each outrigger beam. The jack cylinders provide the force for the outrigger beam's vertical movement. The cylinder weighs approximately 64.6 kg (142.4 lb).

Maintenance

NOTE: Refer to **CYLINDERS** in Section 2 - **HYDRAULIC** and **PRESSURE SETTINGS** for Disassembly and Assembly of the cylinders.

Removal

1. Extend the outrigger beam slightly for improved access to the jack cylinder; shut down the engine.
2. Tag and disconnect the hydraulic hoses from the jack cylinder. Remove the fittings from the ports. Cap or plug all openings.
3. Remove the nut and washer and remove the cylinder cap.
4. Place a jack capable of supporting the weight of the jack cylinder at the base of the cylinder barrel. Jack up the cylinder just enough to relieve any pressure on the cylinder retaining pin.
5. Remove the cotter pins securing the cylinder retaining pin and remove the cylinder retaining pin and cylinder cap retaining bracket.
6. Jack the jack cylinder up just enough to insert the retaining pin back into the cylinder. Insert the retaining pin into the lugs on the cylinder and secure the pin in place with the cotter pins.

CAUTION

Use a nylon strap to remove the cylinder. This will ensure the retaining pin is not damaged.

7. Fasten a nylon strap onto the cylinder retaining pin and use an adequate lifting device to lift the jack cylinder out of the tube on the beam assembly.

Installation

1. Apply grease (EPMPG) to the ID of the jack cylinder support tube.
2. If removed, install wear ring in groove in bottom of support tube and in groove at top on jack cylinder.
3. Place a jack beneath the cylinder tube on the outrigger beam. Using the same method as described under **REMOVAL**, lower the jack cylinder into the cylinder tube on the outrigger beam until the retaining pin is just above

the tube. Position the jack so that it will support the cylinder in this position. Remove the lifting device from the cylinder.

4. Remove the retaining pin and cotter pins from the cylinder.
5. Lower the jack until the holes in the cylinder rod align with the holes in the outrigger beam.
6. Apply anti-seize compound to the retaining pin. Secure the cylinder and cylinder cap retaining bracket to the support tube with the retaining pin and cotter pins.
7. Install the cylinder cap.
8. Install the fittings in the cylinder ports and connect the hoses as tagged during removal.

Functional Check

1. Activate the hydraulic system.
2. Extend and retract the jack cylinder.
3. Check for smooth operation of the cylinder.
4. Check all hydraulic connections and hoses for evidence of leakage.

Outrigger Jack Cylinder Internal Leak Test

Use the following procedure to troubleshoot and diagnose an internal leak, a leaking pilot operated check valve or a thermal contraction on an outrigger jack cylinder.



DANGER

Perform the following procedures with the crane positioned on a firm level surface with outriggers fully extended and set, and the crane in the travel position

Remove hoses from one cylinder at a time.

Checking Cylinder For Internal Piston Seal Leak

1. Fully extend and set the outriggers.

CAUTION

When performing step number 2, remove hose to adapter connection slowly. Trapped pressure may exit between the outrigger cylinder and the work port pilot operated check valves in the outrigger selector valve.

2. Remove the rod side cylinder hose from the suspected leaking jack cylinder (Figure 8-34). Oil will flow until the cavity in the cylinder port block empties. Once the port block cavity empties, oil should stop flowing from the rod side port.

Check for the following conditions:

- a. If oil stops flowing, the cylinder's internal piston seal is sealing properly.
- b. If oil continues to flow out the rod port, the cylinder's internal piston seal is leaking.

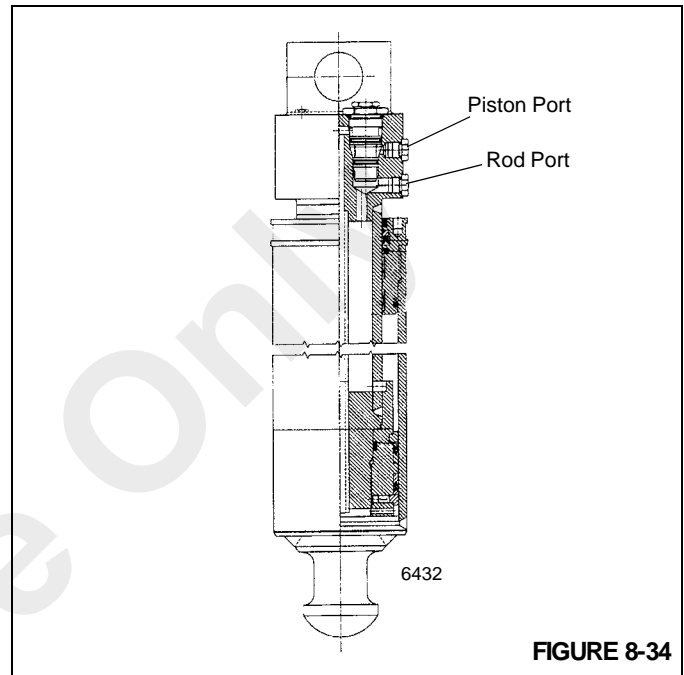

FIGURE 8-34

3. After determining the condition of the cylinder's internal piston seal, let the rod side hose disconnected and continue to test the pilot operated check valve.

Testing Pilot Operated Check Valve For Leakage

1. Fully extend and set the outriggers.

CAUTION

When performing step number 2, remove hose to adapter connection slowly. Trapped pressure may exit between the outrigger cylinder and the work port pilot operated check valves in the outrigger selector valve.

2. Remove the piston side cylinder hose from the suspected leaking jack cylinder, see (Figure 8-34). Oil will flow until the cavity in the cylinder port block empties. Once the port block cavity empties, oil should stop flowing from the piston side port.
 - a. If oil stops flowing, the cylinder's pilot operated check valve is sealing properly.
 - b. If oil continues to flow out the piston port, the cylinder's pilot operated check valve is leaking.

If oil flow is not noticed from either port, the cylinder and pilot operated check valve are functioning properly, and any cylinder contraction during normal operation can be attributed to thermal contraction of the oil.

Outrigger Control Valves

Description

There are four valve assemblies responsible for controlling the outrigger system, the integrated outrigger/rear steer valve, the front and rear outrigger control manifolds, and the pilot operated check valves.

NOTE: For a more detailed description and maintenance of the valves, refer to Valves in Section 2 - HYDRAULIC and PRESSURE SETTINGS.

Pilot Operated Check Valve

The pilot operated check valves are located in the outrigger jack port blocks. The check valve provides two functions; the

first function is a holding valve, the second function provides a thermal relief of the jack.

Integrated Outrigger/Rear Steer Manifold

The integrated outrigger/rear steer valve is mounted on the frame center section to the rear of the front axle. Refer to Section 2 - HYDRAULIC and PRESSURE SETTINGS.

Outrigger Control Manifold

The front and rear outrigger control manifolds are located on the respective outrigger boxes. Each manifold consists of four 2-position, 2-way solenoid valves.

Reference Only

SECTION 9 LUBRICATION

SECTION CONTENTS

General	9-1	Drive Train (continued)	9-11
Environmental Protection	9-1	Outriggers	9-13
Lubrication Intervals	9-1	Turntable	9-15
Arctic Conditions Below -18°C (0°F)	9-1	Boom	9-17
Arctic Conditions Down To -40°F	9-2	Boom (continued)	9-19
Surface Protection for Cylinder Rods	9-2	Hoist	9-21
Wire Rope Lubrication	9-3	Hydraulic	9-23
Lubrication Points	9-4	Carwell® Rust Inhibitor	9-25
CraneLUBE	9-4	Protecting Cranes From Rusting	9-25
Safety	9-4	Cleaning Procedures	9-25
Steering and Suspension	9-5	Inspection and Repair	9-26
Axles	9-7	Application	9-26
Drive Train	9-9	Areas of Application	9-26

GENERAL

Following the designated lubrication procedures is important in ensuring maximum crane lifetime and utilization. The procedures and lubrication charts in this section include information on the types of lubricants used, the location of the lubrication points, the frequency of lubrication, and other information.

ENVIRONMENTAL PROTECTION

Dispose of waste properly! Improperly disposing of waste can threaten the environment.

Potentially harmful waste used in Manitowoc cranes includes — but is not limited to — oil, fuel, grease, coolant, air conditioning refrigerant, filters, batteries, and cloths which have come into contact with these environmentally harmful substances.

Handle and dispose of waste according to local, state, and federal environmental regulations.

When filling and draining crane components, observe the following:

- Do not pour waste fluids onto the ground, down any drain, or into any source of water.
- Always drain waste fluids into leak proof containers that are clearly marked with what they contain.
- Always fill or add fluids with a funnel or a filling pump.
- Immediately clean up any spills.

LUBRICATION INTERVALS

The service intervals specified are for normal operation where moderate temperature, humidity, and atmospheric conditions prevail. In areas of extreme conditions, the service periods and lubrication specifications should be altered to meet existing conditions. For information on extreme condition lubrication, contact your local Grove Distributor or Manitowoc Crane Care.

CAUTION

Chassis grease lubricants must not be applied with air pressure devices as this lubricant is used on sealed fittings.

CAUTION

The multipurpose grease installed during manufacture is of a lithium base. Use of a noncompatible grease could result in damage to equipment.

Arctic Conditions Below -18°C (0°F).

In general, petroleum based fluids developed especially for low temperature service may be used with satisfactory results. However, certain fluids, such as halogenated hydrocarbons, nitro hydrocarbons, and phosphate ester hydraulic fluids, might not be compatible with hydraulic system seals and wear bands. If you are in doubt about the

suitability of a specific fluid, check with your authorized Grove distributor or Manitowoc Crane Care.

NOTE: All fluids and lubricants may be purchased by contacting the Manitowoc Crane Care Parts Department.

Regardless of temperature and oil viscosity, always use suitable start-up procedures to ensure adequate lubrication during system warm-up.

Arctic Conditions Down To -40°F.

ALL Weather Package & Lubricants

Engineering recommends the following lubricants for components for ambient temperatures to -40F. Special lubricants alone are not sufficient to operate at extreme low temperatures. We also recommend the use of appropriately sized heaters for the hydraulic tank, engine oil pan, engine jacket water and batteries. The operator needs to follow the guide lines as stated in the operator manual. We assume that the customer has take steps for use of an appropriate engine antifreeze coolant, have taken care of the fuel, fuel system and starting system. And has done whatever they feel necessary to add insulation for under hood temperatures and meet the engine manufacture's intake air temperature. Other lubricants may be used if they meet the specification of the lubricant that is requested. Please consult factory.

Axles and Swing Box -- Petro- Canada Traxon E Synthetic 75W-90; CITGO, Synthetic Gear Lube 75W-90; Eaton, Roadranger EP75W-90; Mobil, Mobilube SCH 75W-90; Shell, Spirax S 75W-90; Sunoco Duragear EP75W-90; -- **Spec 6829014058**

Engine -- Petro-Canada Duron Synthetic CI-4- 5W-40; Mobil Delvac 1, 5W-40; -- **Spec 6829101560**

Hydraulic tank and Transmission -- Petro-Canada Duratran Synthetic THF; Chevron All Weather THF; Texaco TDH Oil SS; -- **Spec 6829101559**

Hoist -- Petro-Canada ENDURATEX Synthetic EP 150; Mobil SHC629; -- **Spec 6829103636**

Grease -- Petro-Canada Precision Synthetic EP1; Mobil: Mobilith SHC 220; -- **Spec 6829104275**

Open Gear Lube -- (bearing/swingdrive teeth) ---Vultrex.... OGL Synthetic All Season -- **No Spec**

Antifreeze Coolant -- Petro-Canada AFC 60/40; Old World Industries, Inc Fleet Charge SCA Pre-charged Antifreeze/ Coolant-60/40; Fleetguard Compleat EG Antifreeze/Coolant Premix 60/40; -- **Spec 6829104212**

Standard Lubricants Package

Axle and Swing Box -- Century Unigear Semi-synthetic SAE 80W-90; Texaco Multigear SS 80W-90; Chevron DELO 80W-90; -- **Spec 6829012964**

Tier 3 Engine -- CI-4 Rated 15W-40 Engine Oil Exxon XD-3; Conoco Fleet Supreme; -- **Spec 6829003483**

Tier 4 Engine -- CJ-4 Rated 15W-40 Engine Oil; Conoco Fleet Supreme EC; Mobil Delvac 1300 Super; -- **Spec 6829104182**

Hydraulic Tank and Transmission -- To meet John Deere Standard JDM J20C – Hyden 052-10W-20; Exxon Torque Fluid 56- 10W-20; Esso Torque Fluid 56- 10W-20; BP- Eldoran UTH & Trak-Tran 9 – 10W20; BP- Blend- 7367 - 10W20; Exxon Mobil 424- 10W-30 -- **Spec 6829006444**

Hoist -- AGMA No. 4 EP Extreme Pressure Gear Lube- Mobil: Mobilfluid 629; Texaco: Meropa 150; -- **Spec 6829100213**

Grease -- EP-MPG- Multipurpose Grease – Citgo Lithoplex MP # 2; Texaco Starplex Moly # 2; Phillips 66 Philube M Grease; Mobil Mobilgrese XHP 222 Special, # 53055-0; Chemtool Inc, Lube-A-Boom-Grease; -- **Spec 6829003477**

Open Gear Lube -- (bearing / swingdrive teeth -- FUCHS: CEPLATTYN 300 SPRAY -- **Spec 6829102971**

Antifreeze Coolant -- AFC – 50/50 Old World Industries, Inc. Fleet Charge SCA Pre-charged Antifreeze/Coolant; Caterpillar DEAC Antifreeze/Coolant; Fleetguard Complete EG Antifreeze/Coolant; -- **Spec 6829101130.**

Surface Protection for Cylinder Rods

Steel cylinder rods include a thin layer of chrome plating on their surfaces to protect them from corroding. However, chrome plating inherently has cracks in its structure which can allow moisture to corrode the underlying steel. At typical ambient temperatures, hydraulic oil is too thick to penetrate these cracks. Normal machine operating temperatures will allow hydraulic oil to warm sufficiently to penetrate these cracks and if machines are operated daily, protect the rods. Machines that are stored, transported, or used in a corrosive environment (high moisture, rain, snow, or coastline conditions) need to have the exposed rods protected more frequently by applying a protectant. Unless the machine is operated daily, exposed rod surfaces will corrode. Some cylinders will have rods exposed even when completely retracted. Assume all cylinders have exposed rods, as corrosion on the end of the rod can ruin the cylinder.

It is recommended that all exposed cylinder rods be protected using Boeshield® T-9 Premium Metal Protectant. Manitowoc Crane Care has Boeshield® T-9 Premium Metal Protectant available in 12 oz. cans that can be ordered through the Parts Department.

Cylinder operation and inclement weather will remove the Boeshield® protectant; therefore, inspect machines once a week and reapply Boeshield® to unprotected rod

WIRE ROPE LUBRICATION

Wire rope is lubricated during manufacturing so that the strands, and individual wires in strands, may move as the rope moves and bends. A wire rope cannot be lubricated sufficiently during manufacture to last its entire life. Therefore, new lubricant must be added periodically throughout the life of a rope to replace factory lubricant which is used or lost. For more detailed information concerning the lubrication and inspection of wire rope, refer to WIRE ROPE in Section 1- INTRODUCTION in the Service Manual.

LUBRICATION POINTS

A regular frequency of lubrication must be established for all lubrication points. Normally, this is based on component operating time. The most efficient method of keeping track of lube requirements is to maintain a job log indicating crane usage. The log must use the engine hourmeter to ensure coverage of lube points that will receive attention based on their readings. Other lubrication requirements must be made on a time basis, i.e. weekly, monthly, etc.

All oil levels are to be checked with the crane parked on a level surface, ensuring that the hoist is level, and in transport position. The oil must have settled for 20 minutes, with the temperature in the $21^{\circ}\text{C} \pm 7^{\circ}\text{C}$ ($70^{\circ}\text{F} \pm 20^{\circ}\text{F}$) range. Variations in oil temperature will cause oil level to fluctuate.

Oil should be visible in sight glass, at least 1/16" from the top or bottom of the sight glass.

On all hoists with a check plug in the drum, the fill plug shall be directly on top of the hoist, and the check plug level.

All grease fittings are SAE STANDARD unless otherwise indicated. Grease non-sealed fittings until grease is seen extruding from the fitting. One ounce (28 grams) of EP-MPG equals one pump on a standard one pound (0.45 kg) grease gun.

Over lubrication on non-sealed fittings will not harm the fittings or components, but under lubrication will definitely lead to a shorter lifetime.

On sealed U-joints, care must be exercised to prevent rupturing seals. Fill only until expansion of the seals first becomes visible.

Unless otherwise indicated, items not equipped with grease fittings, such as linkages, pins, levers, etc., should be lubricated with oil once a week. Motor oil, applied sparingly, will provide the necessary lubrication and help prevent the formation of rust. An Anti-Seize compound may be used if rust has not formed, otherwise the component must be cleaned first.

Grease fittings that are worn and will not hold the grease gun, or those that have a stuck check ball, must be replaced.

Where wear pads are used, cycle the components and relubricate to ensure complete lubrication of the entire wear area.

CraneLUBE

Manitowoc highly recommends the use of CraneLUBE lubricants to increase your crane's reliability and performance. Contact your Manitowoc Distributor for information about the Manitowoc's CraneLUBE lubrication program.

Safety

To lubricate many of the locations the engine will need to be started. After positioning areas of the unit for lubrication the engine must be turned off and the moved areas stable before approaching.



Movement of the superstructure and the boom may create a crushing and/or pinching hazard. Failure to observe this warning could result in death or serious injury if the message is ignored.

Steering and Suspension						
Item	Lube Point Description	Figure No.	Approved Lubricant	Lube Capacity	Lube Interval	Application
1	Steer Cylinder Pivot Pins	Figure 9-1	EP-MPG Extreme Pressure Multipurpose Grease 6829003477	Until grease extrudes	500 hours or 3 months	8 grease fittings
2	Upper and Lower King Pins	Figure 9-1	EP-MPG Extreme Pressure Multipurpose Grease 6829003477	Until grease extrudes	500 hours or 3 months	8 grease fittings
3	Fifth Wheel Pivots	Figure 9-1	EP-MPG Extreme Pressure Multipurpose Grease 6829003477	Until grease extrudes	500 hours or 3 months	2 grease fittings
4	Lockout Cylinder Pivot Pins	Figure 9-1	EP-MPG Extreme Pressure Multipurpose Grease 6829003477	Until grease extrudes	500 hours or 3 months	4 grease fittings

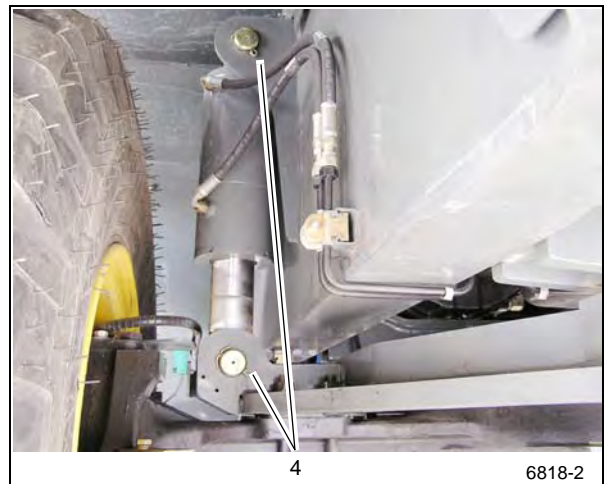
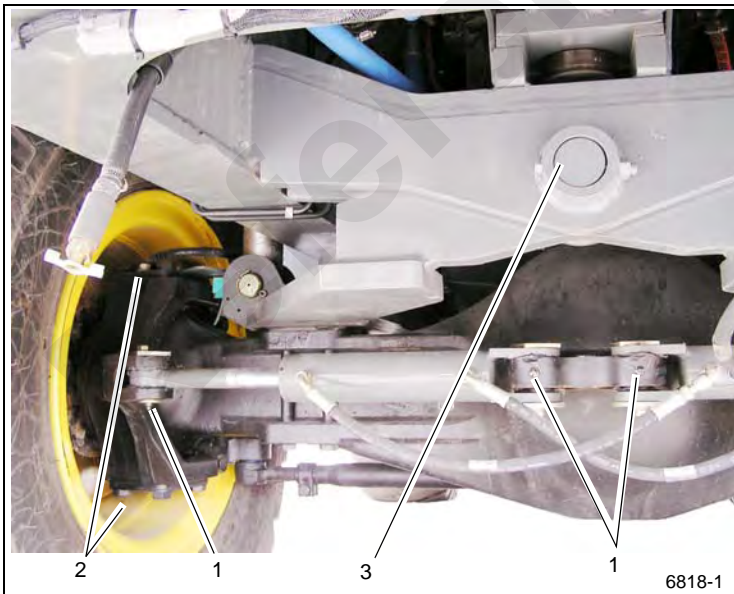
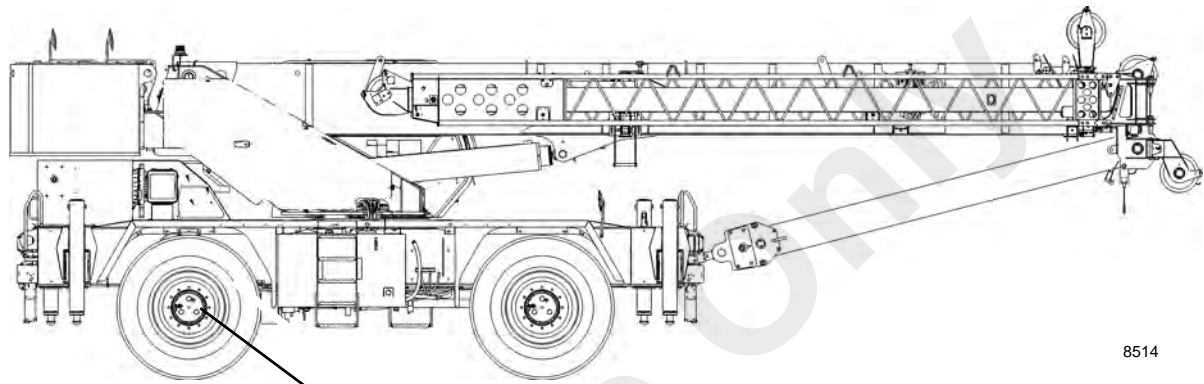

FIGURE 9-1

Item	Lube Point Description	Figure No.	Approved Lubricant	Lube Capacity	Lube Interval	Application
Axles						
6	Axle Tech Differentials	Figure 5-2	GL-5 Extended Service Interval Gear Lubricant 6829012964	20.8 l (44 pt)	<ul style="list-style-type: none"> • Check level every 500 hours or 3 months • Drain and fill every 4000 hours or 2 years 	Fill to bottom of hole in housing on the steer cylinder side
<p>NOTE: Lube level close enough to the hole to be seen or touched is not sufficient. It must be level with the hole. When checking lube level, also check and clean housing breathers.</p> <p>CAUTION: Use of non-approved lubricant may damage components and/or invalidate published lubricant intervals.</p> <p>CAUTION: If the makeup amount is substantially more than 0.23 liter (0.5 pint), check for leaks.</p>						
9	Axle Tech Planetary Hubs and Wheel Bearings	Figure 5-2	GL-5 Extended Service Interval Gear Lubricant 6829012964	3.1 l (6.5 pt)	<ul style="list-style-type: none"> • Check level every 500 hours or 3 months • Drain and fill every 4000 hours or 2 years 	Fill to the bottom of the level hole in the housing with the fill plug and the oil level mark horizontal.
<p>CAUTION: Use of non-approved lubricant may damage components and/or invalidate published lubricant intervals.</p>						

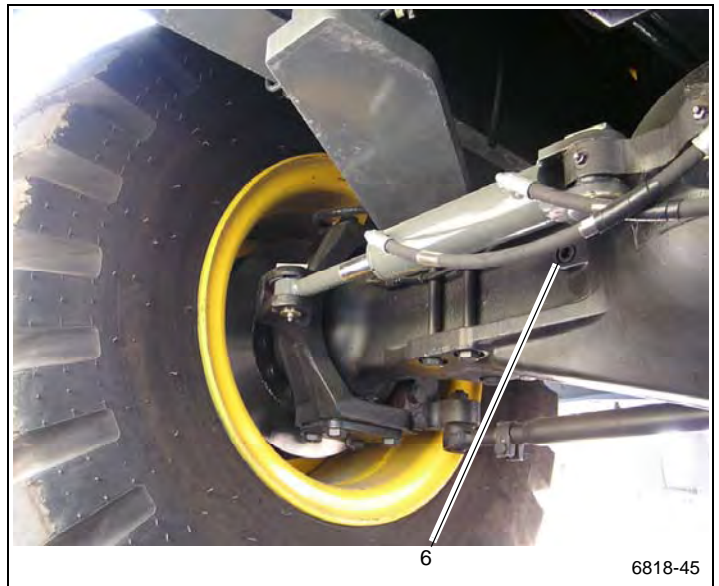
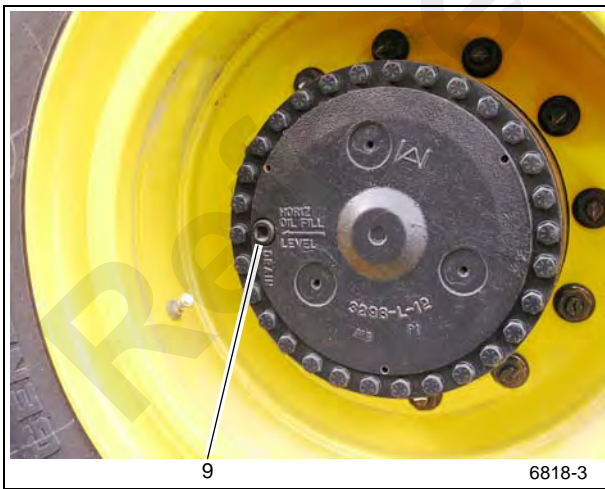
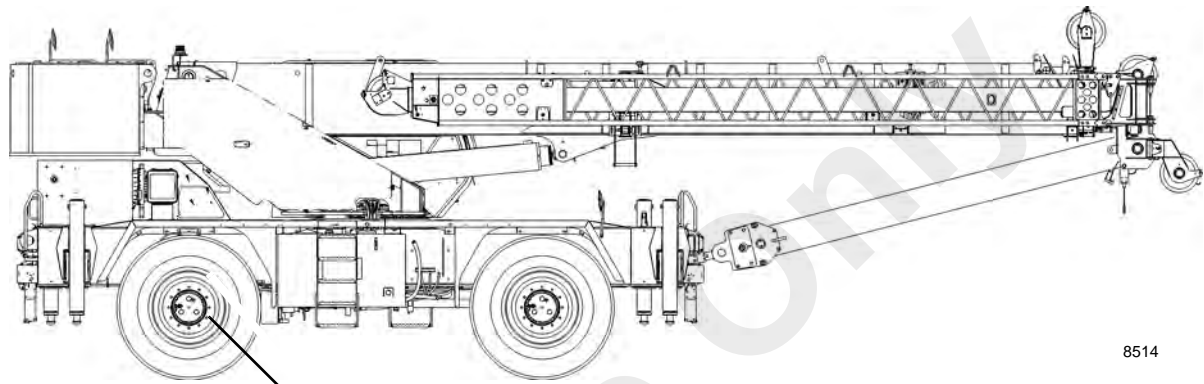
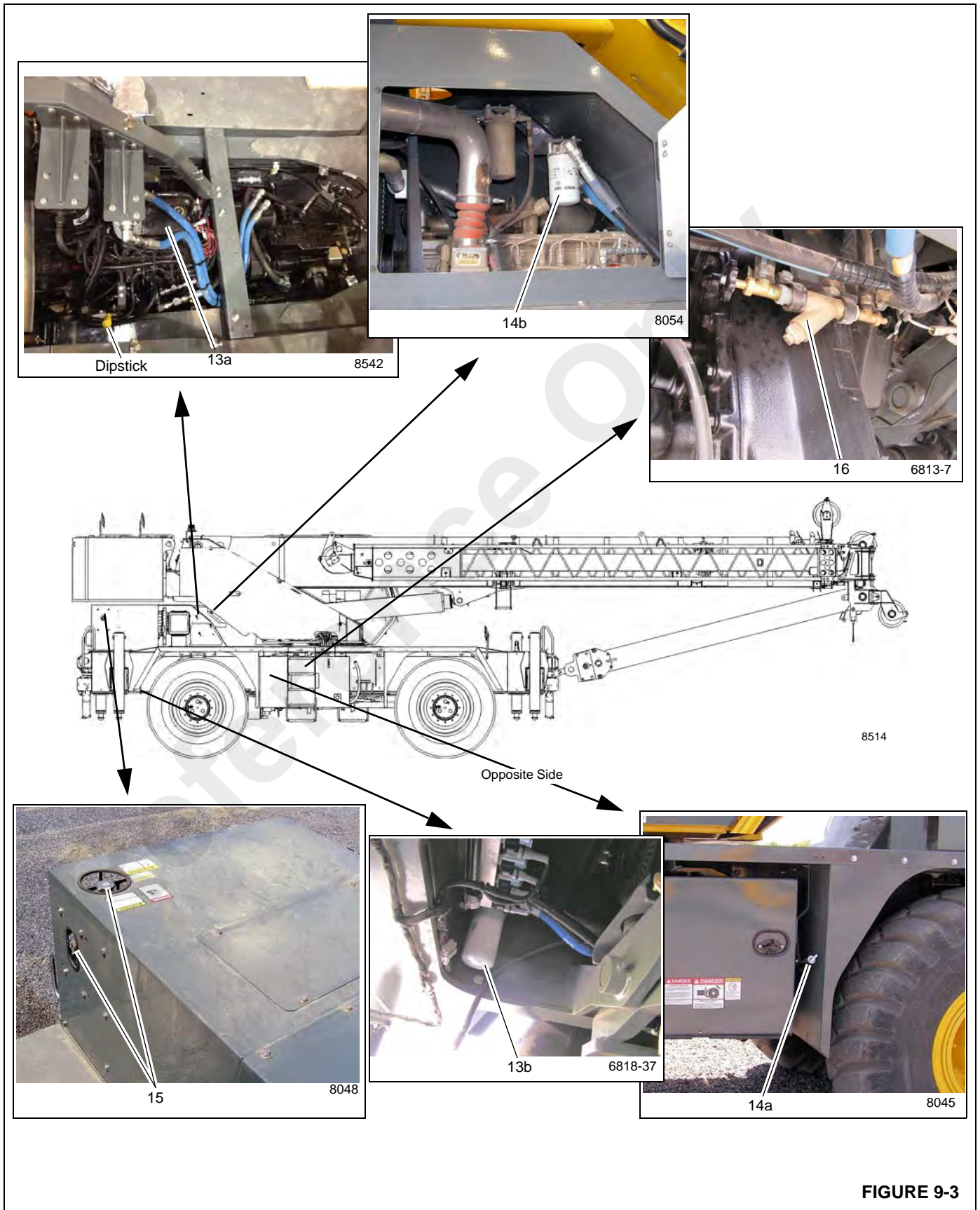

FIGURE 9-2

Item	Lube Point Description	Figure No.	Approved Lubricant	Lube Capacity	Lube Interval	Application
Drive Train						
13a 13b	Engine Crankcase Filter	Figure 9-3	EO-15W/40 Engine Oil SAE 15W-40 T3 Engine - 6829003483 T4 Engine - 6829104182	17.5 l (18.5 qt)	<ul style="list-style-type: none"> Check level every 10 hours or daily Drain, fill and replace filter every 500 hours or 6 months 	<ul style="list-style-type: none"> Check level through dipstick. Fill engine oil through fill cap on engine valve cover.
14a 14b	Transmission, Torque Converter a. Dipstick b. Filter	Figure 9-3	HYDO Hydraulic Oil 6829006444	23.6 l (25 qt)	<ul style="list-style-type: none"> Check level every 10 hours or daily Drain and refill every 1000 hours or 6 months Change transmission filter after first 50 and 100 hours of service, then every 500 hours thereafter 	Through fill pipe to FULL mark on dipstick
NOTE:						
<ul style="list-style-type: none"> Check fluid level with engine running at 750 rpm idle and the oil at 180 to 200 ° F (82 to 93° C). Do not attempt an oil level check with cold oil. To bring the oil temperature to this range, it is necessary to either work the crane or stall the converter. Converter stall should be accomplished by engaging shift lever in forward high range with the brakes applied and then accelerating the engine to half or three-quarter throttle. Hold the stall until the required converter temperature is reached and stabilized. <p>Do not operate the converter at stall condition for longer than 30 seconds at one time. Shift to neutral for 15 seconds and repeat the procedure until the desired temperature is reached. Excessive temperature, i.e, 250° F (120° C) maximum will cause damage to transmission clutches, fluid, converter and seals.</p> <ul style="list-style-type: none"> Drain and fill with the oil at 150 to 200° F (65 to 93° C). Transmission filters are located on the outside left hand frame in the area of the hydraulic oil cooler. To add fluid: <ul style="list-style-type: none"> a. Fill to FULL mark on dipstick b. Run engine at 750 rpm to prime torque converter and lines c. Check oil level with engine running at 750 rpm and oil at 180 to 200° F (82 to 93° C (180 to 200° F). Add oil to bring oil level to FULL mark on dipstick. 						
15	Engine Cooling System and SCA Levels	Figure 9-3	AFC 50/50 50/50 Blended Fully Formulated Antifreeze Coolant 6829101130 SCA 6829012858	28.4 l (30 qt)	<ul style="list-style-type: none"> Check coolant level every 10 hours or daily Check SCA levels every 500 hours Check coolant for contamination every 1000 hours 	See <i>Service Manual</i>
16	Coolant Strainer (Cab Heater)	Figure 9-3	---	---	Change strainer screen after first 100 hours and every 2000 hours or 12 months intervals thereafter.	Close shutoff valves. Unscrew hex plug to clean filter.



Item	Lube Point Description	Figure No.	Approved Lubricant	Lube Capacity	Lube Interval	Application
Drive Train (continued)						
17	Driveline - Slip Joints	Figure 9-4	EP-MPG Extreme Pressure Multipurpose Grease 6829003477	Until grease extrudes	500 hours or 3 months	2 grease fittings
52	Air Cleaner Filter	Figure 9-4	---	---	<ul style="list-style-type: none"> • Replace/Clean filter element when indicator shows red (25" H₂O). • View indicator through grill from rear of crane. • Refer to Service Manual 	Remove panel behind ladder to access air filter.
53a	a. Fuel Filter	Figure 9-4	---	---	<ul style="list-style-type: none"> • Change filter every 500 hours or 6 months. • Drain water trap every 10 hours or daily. 	<ul style="list-style-type: none"> • Fuel filter is located on the intake manifold of engine. • Strainer is located near fuel tank
53b	b. Water Separator					

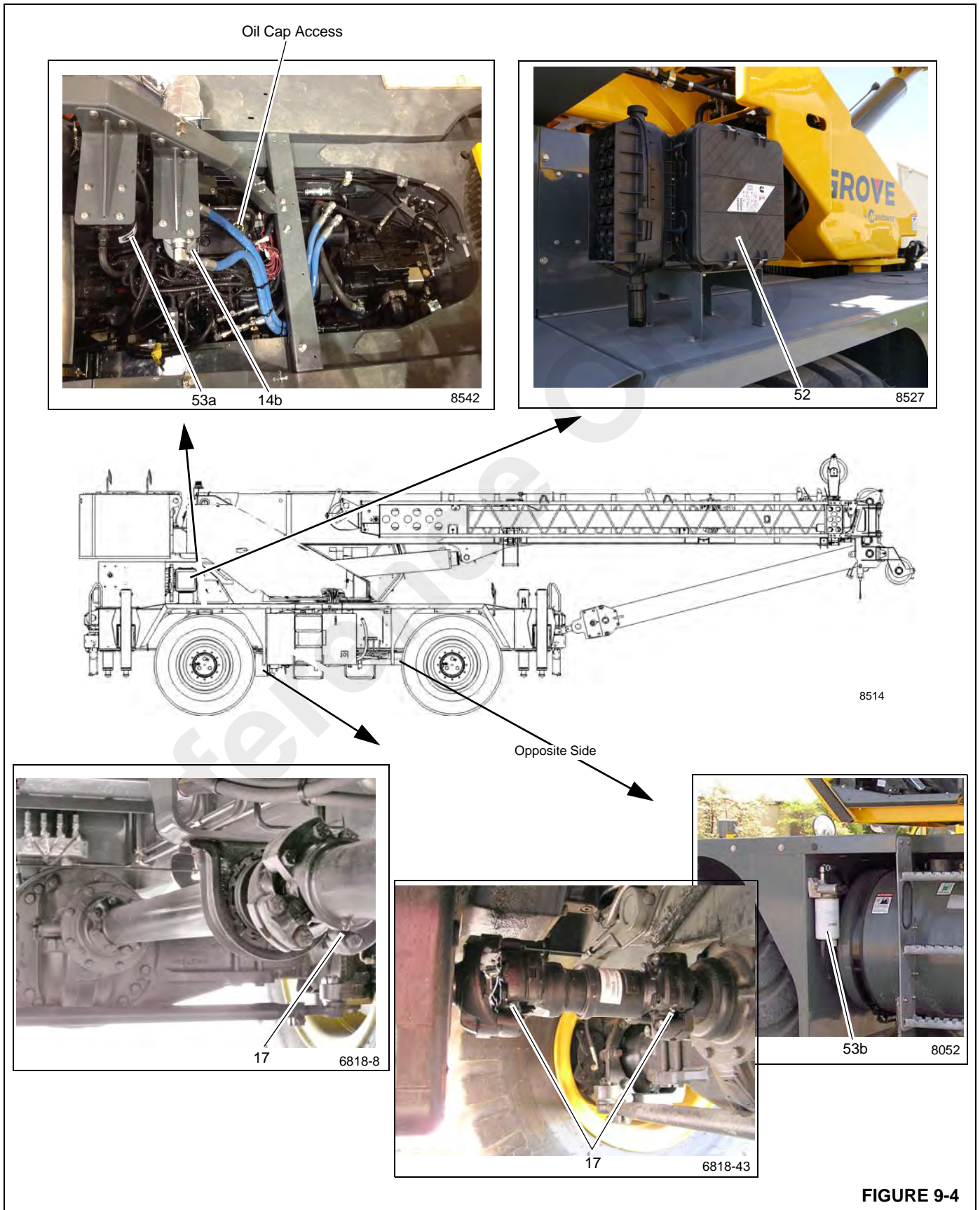
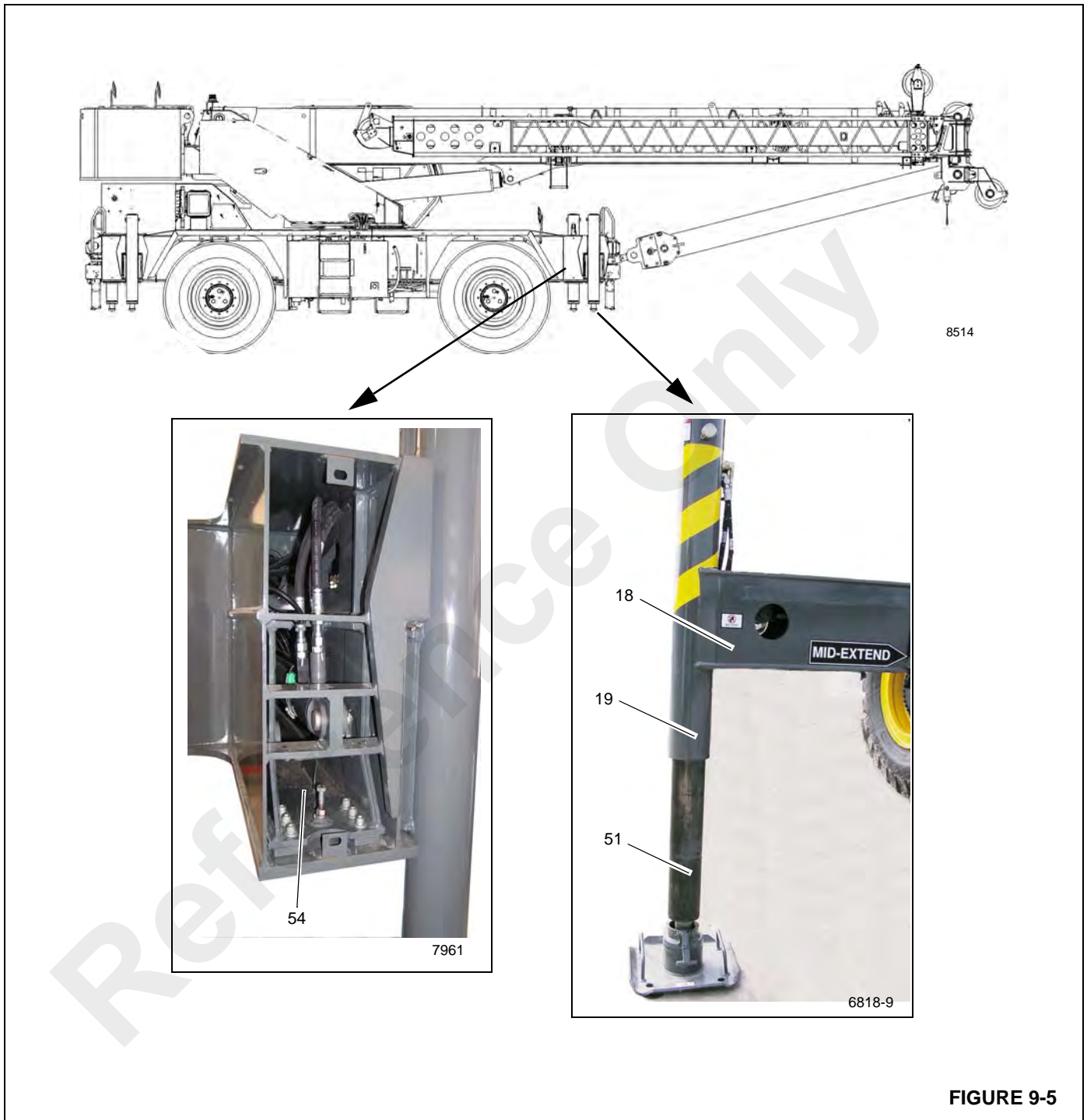

FIGURE 9-4

Item	Lube Point Description	Figure No.	Approved Lubricant	Lube Capacity	Lube Interval	Application
Outriggers						
18	Outrigger Beams (Outside)	Figure 9-5	EP-MPG Extreme Pressure Multipurpose Grease 6829003477	---	50 hours or 1 week	Brush lubricant on bottom of outrigger beams
19	Jack Cylinder Support Tubes	Figure 9-5	EP-MPG Extreme Pressure Multipurpose Grease 6829003477	---	50 hours or 1 week	Brush lubricant on OD of jack cylinder barrel and wear band before installing jack cylinders
51	Jack Cylinder Barrels	Figure 9-5	EP-MPG Extreme Pressure Multipurpose Grease 6829003477	---	50 hours or 1 week	Brush lubricant on OD of jack cylinder support tubes (4) places before installing jack cylinders
54	Outrigger Beams (Inside)	Figure 9-5	EP-MPG Extreme Pressure Multipurpose Grease 6829003477	---	50 hours or 1 week	Brush lubricant on inside bottom of outrigger beams where beam extension cylinder guide supports travel



Item	Lube Point Description	Figure No.	Approved Lubricant	Lube Capacity	Lube Interval	Application
Turntable						
20	Turntable Gear Box	Figure 9-6	GL-5 Extended Service Interval Gear Lubricant 6829012964	4.0 l (4.25 qt)	<ul style="list-style-type: none"> Check and fill every 50 hours Drain and fill after first 250 hours and every 500 hours or 12 months thereafter. 	Use dipstick. If no dipstick, fill to top of case.
21	Turntable Gear and Drive Pinion	Figure 9-6	EP-OGL Open Gear Lubricant 6829102971	Coat all teeth	500 hours or 6 months	Spray on
22	Turntable Bearing	Figure 9-6	EP-MPG Extreme Pressure Multipurpose Grease 6829003477	Until grease extrudes the whole circumference of the bearing	500 hours or 6 months	2 grease fittings at the front of the turntable
NOTE: Rotate the turntable 90° and apply grease to fittings. Continue rotating 90° and grease the fittings until the whole bearing is greased.						



FIGURE 9-6

Item	Lube Point Description	Figure No.	Approved Lubricant	Lube Capacity	Lube Interval	Application
Boom						
25	Upper Lift Cylinder Pin	Figure 9-7	EP-MPG Extreme Pressure Multipurpose Grease 6829003477	Until grease extrudes	500 hours or 3 months	1 grease fittings
29	Hook Block Swivel Bearing	Figure 9-7	EP-MPG Extreme Pressure Multipurpose Grease 6829003477	Until grease extrudes	250 hours or 3 months	1 grease fitting
30	Hook Block Sheaves	Figure 9-7	EP-MPG Extreme Pressure Multipurpose Grease 6829003477	Until grease extrudes	250 hours or 3 months	4 grease fittings - 35 Tons 3 grease fittings - 35 Tons
31	Telescope Cylinder Wear Pads	Figure 9-7	EP-MPG Extreme Pressure Multipurpose Grease 6829003477	Thoroughly coat	Every boom teardown or 125 hours/3 months	2 places by brush Extend boom for access through holes
32	Side Wear Pads	Figure 9-7	EP-MPG Extreme Pressure Multipurpose Grease 6829003477	Thoroughly coat all areas the wear pad moves on	250 hours or 3 months	12 places by brush; with boom in extended position
33	Boom Section Upper Wear Pads	Figure 9-7	EP-MPG Extreme Pressure Multipurpose Grease 6829003477	Thoroughly coat all areas the wear pad moves on	50 hours or 1 week	6 places by brush; with boom in extended position through access holes
34	Boom Section Lower Wear Pads	Figure 9-7	EP-MPG Extreme Pressure Multipurpose Grease 6829003477	Thoroughly coat all areas the wear pad moves on	50 hours or 1 week	3 places by brush; with boom in extended position
35	Extend Cable Sheaves	Figure 9-7	EP-MPG Extreme Pressure Multipurpose Grease 6829003477	Until grease extrudes	250 hours or 3 months	3 grease fittings Extend boom for access through holes
36	Retract Cable Sheaves	Figure 9-7	EP-MPG Extreme Pressure Multipurpose Grease 6829003477	Until grease extrudes	250 hours or 3 months	4 grease fittings
NOTE: Lubricate items more frequently than interval indicated in table if environmental conditions and/or operating conditions necessitate.						

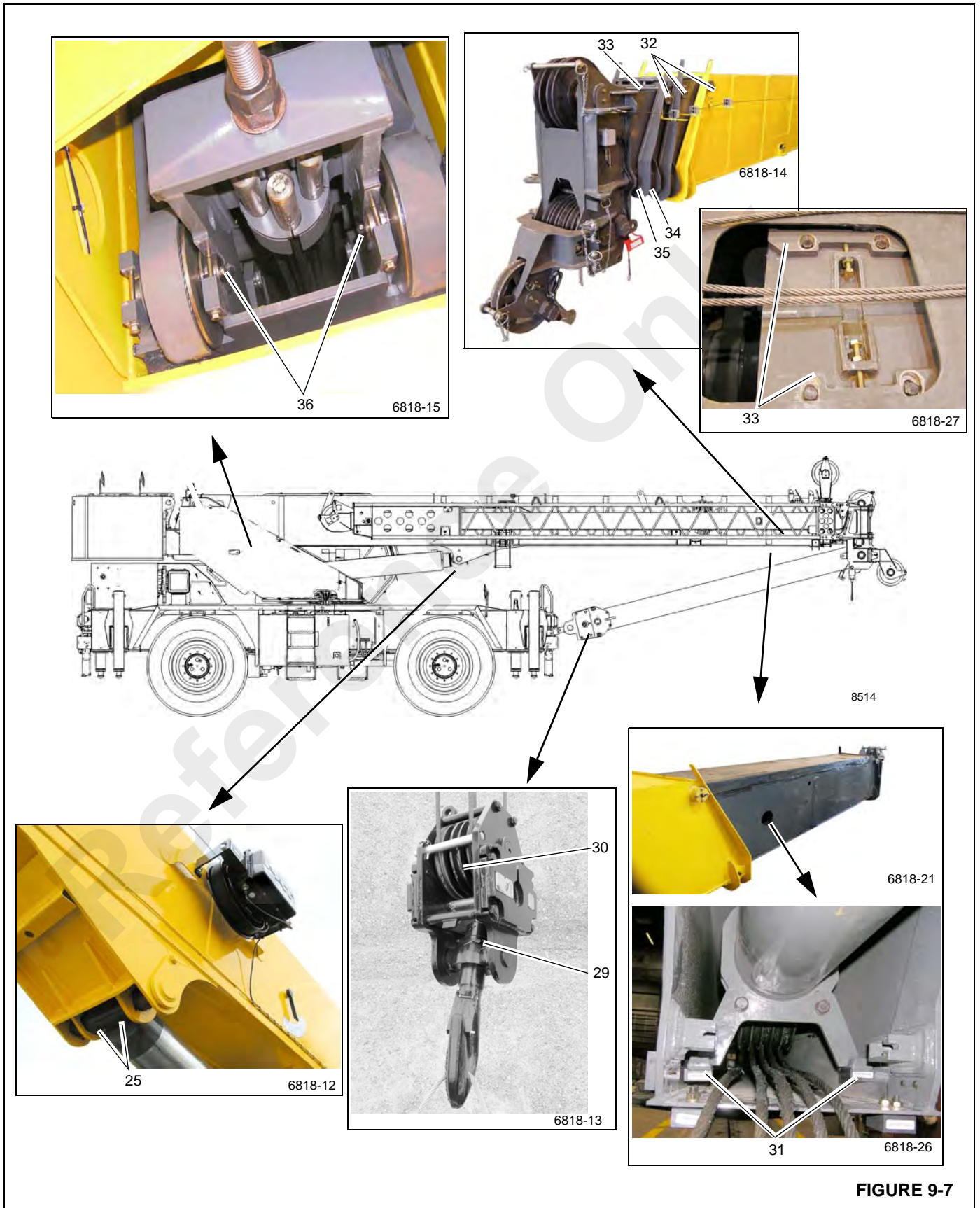

FIGURE 9-7

Item	Lube Point Description	Figure No.	Approved Lubricant	Lube Capacity	Lube Interval	Application
Boom (continued)						
37	Boom Pivot Shaft	Figure 9-8	EP-MPG Extreme Pressure Multipurpose Grease 6829003477	Until grease extrudes	250 hours or 3 months	2 grease fittings
38	Boom Extension Sheave	Figure 9-8	EP-MPG Extreme Pressure Multipurpose Grease 6829003477	Until grease extrudes	250 hours or 3 months	1 grease fitting
39	Boom Extension Rollers	Figure 9-8	EP-MPG Extreme Pressure Multipurpose Grease 6829003477	Until grease extrudes	250 hours or 3 months	4 grease fittings
40	Upper Boom Nose Sheave	Figure 9-8	EP-MPG Extreme Pressure Multipurpose Grease 6829003477	Until grease extrudes	250 hours or 3 months	1 grease fitting
41	Lower Boom Nose Sheave	Figure 9-8	EP-MPG Extreme Pressure Multipurpose Grease 6829003477	Until grease extrudes	250 hours or 3 months	1 grease fitting
42	Auxiliary Boom Nose Sheave	Figure 9-8	EP-MPG Extreme Pressure Multipurpose Grease 6829003477	Until grease extrudes	250 hours or 3 months	1 grease fitting
43	Mast Sheave	Figure 9-8	EP-MPG Extreme Pressure Multipurpose Grease 6829003477	Until grease extrudes	500 hours or 12 months	1 grease fitting

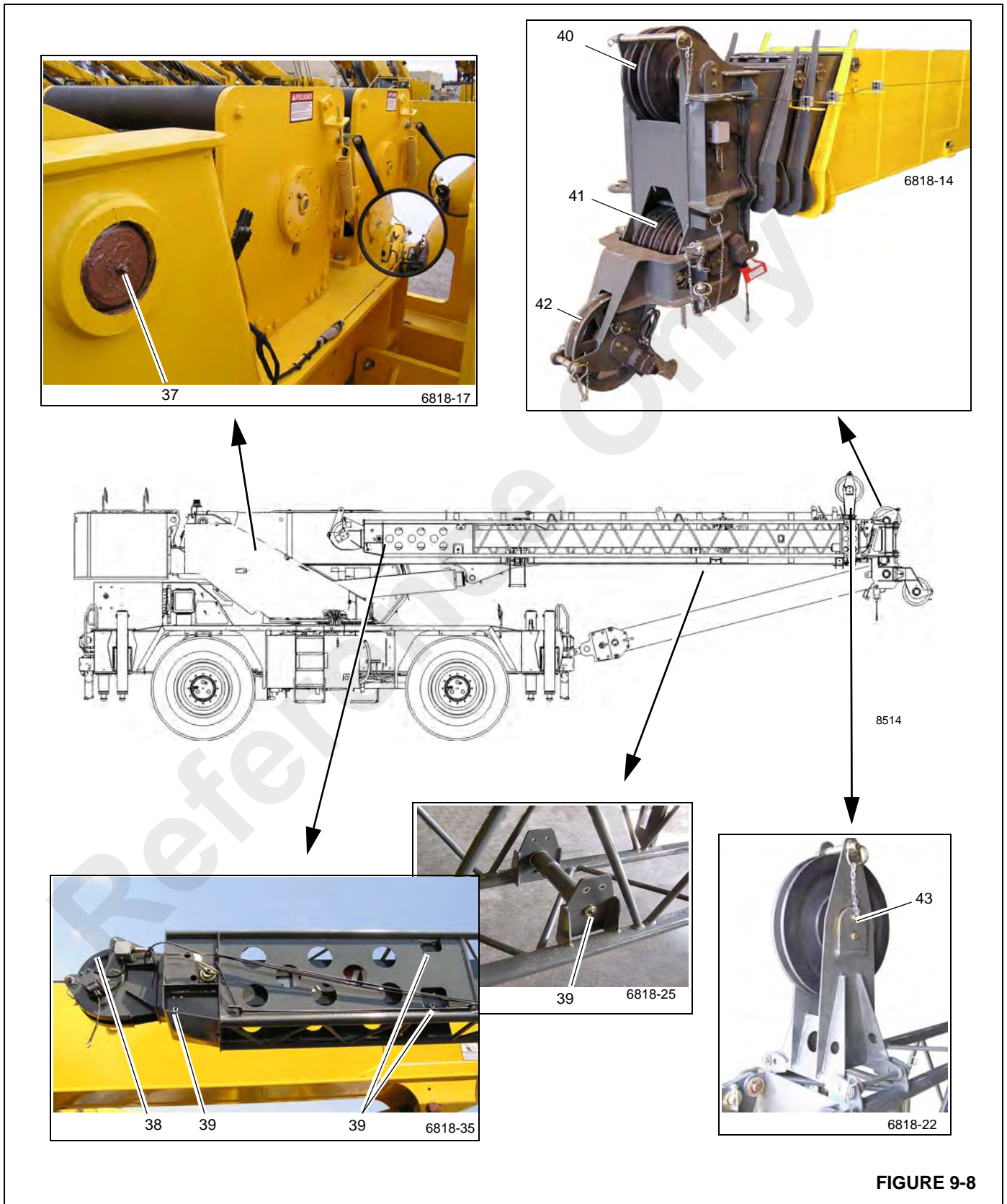
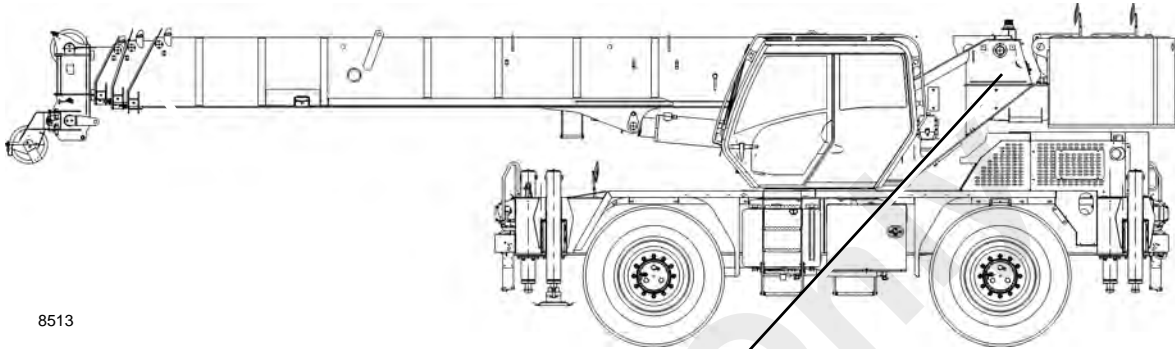

FIGURE 9-8

Item	Lube Point Description	Figure No.	Approved Lubricant	Lube Capacity	Lube Interval	Application
Hoist						
45	Main Hoist	Figure 9-9	AGMA Extreme Pressure Gear Lubricant 6829100213	5.2 l (5.5 qt)	<ul style="list-style-type: none"> Check and fill every 50 hours or weekly Drain and fill every 1000 hours or 12 months 	Oil level must be visible in the sight glass (see note)
46	Auxiliary Hoist	Figure 9-9	AGMA Extreme Pressure Gear Lubricant 6829100213	5.2 l (5.5 qt)	<ul style="list-style-type: none"> Check and fill every 50 hours or weekly Drain and fill every 1000 hours or 12 months 	Oil level must be visible in the sight glass (see note)
<p>NOTE: Line up the Fill/Drain Plug with the upper cutout hole (A). Let hoist sit idle for 20 minutes for an accurate reading. Ensure hoist is level and oil temperature is 21°C ±11°C (70°F ±20°F). If oil level is not visible in sight glass, the hoist may be under filled. Oil escaping from vent plug is an indication the hoist may be over filled. If hoist is over filled, move the Fill/Drain Plug to the lower cutout hole (B) and drain until oil level falls within the sight glass.</p>						
47	Cable Follower (Arms)	(Figure 9-9)	EP-MPG Extreme Pressure Multipurpose Grease 6829003477	Thoroughly coat	250 hours or 3 months	Spray on
<p>NOTE: Lubricate more frequently than interval indicated in table if environmental conditions and/or operating conditions necessitate.</p>						



8513



6818-17

FIGURE 9-9

Item	Lube Point Description	Figure No.	Approved Lubricant	Lube Capacity	Lube Interval	Application
Hydraulic						
48	Hydraulic Tank	Figure 9-10	HYDO Hydraulic Oil 6829006444	397.4 l (105 gal)	Check fluid level every 10 hours or daily.	<ul style="list-style-type: none"> Use sight gauge on side of tank, with boom down and all outrigger cylinders retracted. Drain and refill as necessary
NOTE:						
<ul style="list-style-type: none"> Environmental and other conditions can dramatically affect the condition of hydraulic oil and filters. Therefore, specific intervals for servicing/changing hydraulic oil, filters and hydraulic tank breathers cannot be set. However, it is imperative for the continued satisfactory performance of Grove cranes that inspections be performed on the basis of how and where each crane is used. Air borne and ingested contaminants can significantly reduce the life of oil and the condition of hydraulic oil filters and tank breathers. Under normal operating conditions, it is recommended that hydraulic oil, filters and breathers be inspected and oils sampled at least every 3 to 6 months and more frequently for severe operating conditions. The inspections should be for air borne and/or ingested particles and water that deteriorate and contaminate the oil (e.g., oil appears "milky" or no longer has a transparent clear to amber color). The return filter by-pass indicator should be observed daily to determine if the contaminants content may be high. If the indicator reaches the red zone or indicates a by-pass condition, the hydraulic oil must be sampled. The hydraulic tank breather should also be inspected to assure that it is not restricting air flow into and out of the reservoir. To inspect hydraulic oil, fill a small glass container with a sample of reservoir oil and another glass container with fresh oil. Let the samples stand, undisturbed, for one to two hours and then compare the samples. If the reservoir oil is heavily contaminated with water the sample will appear "milky" with only a small layer of transparent oil on top. If the "milky" appearance was due to air foaming, it will dissipate and the oil should closely match the fresh oil. Should you have any questions, please contact your local authorized Manitowoc distributor. The hydraulic oil shall meet or exceed ISO #4406 class 17/14 cleanliness level. 						
49	Hydraulic Filter	Figure 9-10	HYDO Hydraulic Oil 6829006444	---	Change filter when the indicator is red	---

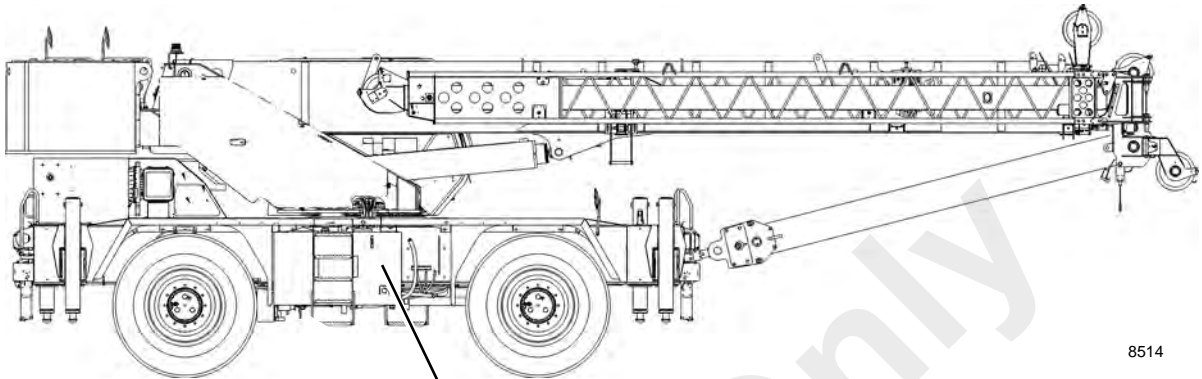

8514



8055

FIGURE 9-10

CARWELL® RUST INHIBITOR

Steering and Suspension						
Item	Lube Point Description	Figure No.	Approved Lubricant	Lube Capacity	Lube Interval	Application
1	Steer Cylinder Pivot Pins	Figure 9-1	EP-MPG Extreme Pressure Multipurpose Grease A6-829-003477	Until grease extrudes	500 hours or 3 months	8 grease fittings
2	Upper and Lower King Pins	Figure 9-1	EP-MPG Extreme Pressure Multipurpose Grease A6-829-003477	Until grease extrudes	500 hours or 3 months	8 grease fittings
3	Fifth Wheel Pivots	Figure 9-1	EP-MPG Extreme Pressure Multipurpose Grease A6-829-003477	Until grease extrudes	500 hours or 3 months	2 grease fittings
4	Lockout Cylinder Pivot Pins	Figure 9-1	EP-MPG Extreme Pressure Multipurpose Grease A6-829-003477	Until grease extrudes	500 hours or 3 months	4 grease fittings

Protecting Cranes From Rusting

Manitowoc Crane Group's cranes are manufactured to high quality standards, including the type of paint finish demanded by today's industry. In partnership with our paint supplier, we are also doing our part to help prevent premature corrosion of cranes.

Grove cranes will be treated with a rust inhibitor called Carwell® T32-CP-90. While a rust inhibitor cannot guarantee that a machine will never rust, this product will help protect against corrosion on Grove cranes that are treated with this product.

Carwell is a treatment, not a coating. It contains no silicones, solvents, CFCs or anything that would be classified as hazardous under OSHA Regulation 29CFR-19-10.1200. The product is a liquid blend of petroleum derivatives, rust inhibitors, water-repelling and water-displacing agents.

Special equipment is used to spray a light film onto the entire undercarriage and various other areas of each new crane prior to shipment. When applied the product has a red tint to allow applicators to view coverage during application. This red tint will turn clear on its own within approximately 24 hours after application.

Once applied, treatment can appear to leave a slightly "oily" residue on painted surfaces and until the red tinting fades could initially be mistaken for a hydraulic oil leak. While the product is not harmful to painted surfaces, glass, plastic or rubber, it must be removed using standard steam-cleaning techniques.

This treatment works in various ways: (1) it eliminates the moisture containing salt, dirt and other pollutants by lifting and removing them from the metal surface; (2) the film creates a barrier to repel further moisture from coming in contact with the metal; and (3) it penetrates crevices.

In addition to the factory-applied treatment, Grove crane owners must provide proper maintenance and care to help ensure long-term protection of their crane against corrosion. This procedure provides information and guidelines to help maintain the paint finish on Grove cranes.

The most common causes of corrosion include the following:

- Road salts, chemicals, dirt, and moisture trapped in the hard-to-reach areas;
- Chipping or wear of paint, caused by minor incidents or moving components;

- Damage caused by personal abuse, such as using the decks to transport rigging gear, tools, or cribbing; and
- Exposure to harsh environmental hazards such as alkaline, acids, or other chemicals that can attack the crane's paint finish.

While the surfaces of the crane that are easily seen have the biggest impact on the appearance of the crane, particular attention should be given to the undercarriage of the crane to minimize the harmful effects of corrosion.

Exercise special care and increase the frequency of cleaning if the crane is operated:

- on roads where large quantities of salt or calcium are applied to treat icy and snowy road surfaces;
- in areas that use dust control chemicals;
- anywhere there are increased levels of wetness - especially near salt water;
- during prolonged periods of exposure to damp conditions (e.g., moisture held in mud), where certain crane parts may become corroded even though other parts remain dry; or
- in high humidity, or when temperatures are just above the freezing point.

Cleaning Procedures

To help protect against corrosion of Grove cranes, Manitowoc Crane Care recommends washing the crane at least monthly to remove all foreign matter. More frequent cleaning may be needed when operating in harsh environmental conditions. To clean the crane, follow these guidelines:

- High pressure water or steam is effective for cleaning the crane's undercarriage and wheel housings. Keeping these areas clean will not only help retard the effects of corrosion, but will also improve the ability to identify potential issues before they grow into larger problems.



CAUTION

High pressure water can be forced into spaces and infiltrate beyond seals. Avoid pressure washing in the vicinity of electrical controls, panels, wiring, sensors, hydraulic hoses and fittings, or anything that can be damaged by high pressure cleaning/spraying.

- Rinse the dirt and dust off before washing the crane. Dirt can scratch the crane's finish during washing/cleaning.
- Hard to clean spots caused by road tar or bugs should be treated and cleaned after rinsing and prior to washing. Do not use solvents or gasoline.

- Wash using only soaps and detergents recommended for automotive paint finishes.
- Rinse all surfaces thoroughly to prevent streaking caused by soap residue.
- Allow the crane to dry thoroughly. You can accelerate drying by using compressed air to remove excess water.

NOTE: Polishing and waxing (using an automotive-type wax) is recommended to maintain the original paint finish.

Inspection and Repair

- Immediately following cleaning, Manitowoc Crane Care recommends an inspection to detect areas that may have become damaged by stone chips or minor mishaps. A minor scratch (one that has not penetrated to the substrate surface) can be buffed with an automotive-type scratch remover. It is recommended that a good coat of automotive wax be applied to this area afterwards.
- All identified spots and/or areas that have been scratched through to the metal should be touched up and repaired as soon as possible to prevent flash rusting. To repair a major scratch (down to bare metal) or minor damage, follow these procedures:

NOTE: Manitowoc Crane Care recommends that a qualified body repairman prepare, prime, and paint major scratches or minor damage.



CAUTION

To the extent any damage is structural in nature, Manitowoc Crane Care must be contacted and consulted as to what repairs may be required.

For scratches and marks in highly visible areas:

- Sand to remove the scratch and feather outward from mark to blend repair into the original surface. Body putty may be applied as necessary to hide the defect; then sand smooth.
- Cover all bare metal with a primer that is compatible with the original paint finish and allow to dry thoroughly.
- Prepare surface before applying finish coat of paint.
- Apply a finish coat paint using accepted blending techniques. Use of original paint colors is recommended to insure the best color match possible.

For scratches and marks in areas of low visibility:

- Consider touching up spots with a brush technique to cover the bare metal. This retards effects of corrosion and enables you to do the repair at a later time during a normal maintenance interval.

Spots should be touched up with quality paint. Primers tend to be porous; using a single coat of primer only will allow air and water to penetrate the repair over time.

Application

Depending upon the environment in which a crane is used and/or stored, the initial factory application of Carwell T32-CP-90 should help inhibit corrosion for up to approximately 12 months.

It is recommended that the treatment be periodically reapplied by the crane owner after that time to help continue to protect against corrosion of the crane and its components.

However, if a crane is used and/or stored in harsh environments (such as islands, coastal regions, industrial areas, areas where winter road salt is regularly used, etc.), reapplication of treatment is recommended sooner than 12 months, e.g., repeat treatment in 6-9 months.

- Do not apply to recently primed and painted areas for at least 48 hours after paint is properly dried and cured. For minor touch up areas a 24 hour period is needed for cure time before applying treatment.

NOTE: Unit must be completely dry before applying treatment.

- Do not allow product to puddle or build-up on weather stripping, rubber gaskets, etc. Unit should not have puddles or runs evident anywhere.
- To ensure proper coverage of treatment, the product needs to be fogged on the unit.
- Use of pressure pots to apply the treatment to the unit being processed is recommended.

- Carwell treatment is available in 16 ounce spray bottles from Manitowoc Crane Care (order part number 8898904099).
- After application of the treatment is complete, wash or clean film residue from lights, windshield, grab handles, ladders/steps and all access areas to crane, as necessary.

Contact Manitowoc Crane Care with any questions.

Areas of Application

Refer to Figure 9-11 and Figure 9-12.

- The underside of the unit will have full coverage of the rust inhibitor. These are the only areas that a full coat of the rust inhibitor is acceptable on the painted surfaces. Areas include; Valves, hose end and fittings, Swivel, pumps, axles, drive lines, transmission, slew ring fasteners and all interior surfaces of the frame.
- Frame application areas are; hose ends and fittings, all unpainted fasteners and hardware, all bare metal surfaces, outrigger pads, and back up alarm hardware.
- Superstructure applications are; hose end and fittings, wire rope on hoist roller tensioning springs on hoists, all unpainted fasteners and hardware, valves, slew ring fasteners and all bare metal surfaces.
- Boom applications areas are; pivot pins, hose end and fittings, jib pins and shafts, all bare metal surfaces, headache ball pins/ hook block pins and fasteners.
- All hardware, clips, pins, hose connections not painted will have treatment applied.



FIGURE 9-12

1	Hoist Tension Springs	12	O/R Beam Wear Pad Adjustment Hardware
2	Boom Extension Pins, Clips	13	Turntable Bearing Fasteners
3	Boom Nose Pins, Clips	14	Entire underside of unit
4	Hook Block/ Headache Ball	15	Power Train Hardware inside compartment
5	Boom Extension Hanger Hardware	16	Valve Bank
6	Pivot Shaft	17	Hoist Hose Connections
7	Hose Connections inside turntable	18	Wire Rope
8	All Hardware, Clips, Pins, Hose Connections not painted O/R Pins, Clips	19	Counterweight Mounting Hardware
9	O/R Hose Connections	20	Counterweight Pins
10	Hookblock Tie Down Cable	21	Hose Connections
11	O/R Pins, Clips	22	Mirror Mounting Hardware

Reference Only

Reference Only