

Provided for Free by Trenchwell.com  
Shop Aftermarket Parts

Printed in U.S.A.

**CASE CORPORATION**  
700 STATE STREET  
RACINE, WI 53404 U.S.A.

**CASE CANADA CORPORATION**  
3350 SOUTH SERVICE ROAD  
BURLINGTON, ON L7N 3M6 CANADA

# L Series Loader Backhoe

## Operators Manual

9-25886

Reprinted

**CASE**



*This symbol means ATTENTION! BECOME ALERT! YOUR SAFETY IS INVOLVED. The message that follows the symbol contains important information about your safety. Carefully read the message. Make sure you fully understand the causes of possible injury or death.*

SB001

IF THIS MACHINE IS USED BY AN EMPLOYEE, IS LOANED, OR IS RENTED, MAKE SURE THAT THE OPERATOR UNDERSTANDS THE TWO INSTRUCTIONS BELOW.

BEFORE THE OPERATOR STARTS THE ENGINE:

1. GIVE INSTRUCTIONS TO THE OPERATOR ON SAFE AND CORRECT USE OF THE MACHINE.
2. MAKE SURE THE OPERATOR READS AND UNDERSTANDS THE OPERATOR'S MANUAL FOR THIS MACHINE.



**IMPROPER OPERATION OF THIS MACHINE CAN CAUSE INJURY OR DEATH.**

BEFORE STARTING THE ENGINE, DO THE FOLLOWING:

1. READ THE OPERATOR'S MANUAL.
2. READ ALL SAFETY DECALS ON THE MACHINE.
3. CLEAR THE AREA OF OTHER PERSONS.

LEARN AND PRACTICE SAFE USE OF MACHINE CONTROLS IN A SAFE, CLEAR AREA BEFORE YOU OPERATE THIS MACHINE ON A JOB SITE.

It is your responsibility to observe pertinent laws and regulations and to follow manufacturer's instructions on machine operation and maintenance.

See your Authorized Case dealer for additional operator's manuals, parts catalogs, and service manuals.

## TABLE OF CONTENTS

TO THE OWNER .....	1
RIGHT, LEFT, FRONT AND REAR OF MACHINE .....	2
IDENTIFICATION NUMBERS .....	3
MACHINE COMPONENTS .....	6 through 9
SAFETY / DECALS / HAND SIGNALS .....	11
SAFETY RULES .....	11
BEFORE OPERATION .....	12
MACHINE OPERATION .....	14
PARKING THE MACHINE .....	16
BURN PREVENTION .....	16
FIRE OR EXPLOSION PREVENTION .....	17
MAINTENANCE .....	18
WHEELS AND TIRES MAINTENANCE .....	19
ROLL-OVER PROTECTIVE STRUCTURE .....	19
CAST DUCTILE IRON .....	20
SAFETY DECALS .....	21
HAND SIGNALS .....	30
INSTRUMENTS AND CONTROLS .....	35
MACHINE CONTROLS .....	37
LOADER CONTROLS .....	49
BACKHOE CONTROLS WITH FOOT SWING .....	51
BACKHOE CONTROLS WITH HAND SWING .....	52
EXTENDAOE CONTROL WITH FOOT SWING .....	53
EXTENDAOE CONTROLS WITH HAND SWING .....	54
AUXILIARY ATTACHMENT CONTROL FOR BACKHOES .....	55
STANDARD SEAT .....	56
SUSPENSION SEAT .....	57
SEAT BELTS .....	59
CAB CONTROLS (If Equipped) .....	60
OPERATING INSTRUCTIONS .....	65
RUN-IN PERIOD OF A NEW MACHINE .....	65
ENGINE OPERATION .....	66
ENGINE STARTING AIDS .....	69
MACHINE OPERATION .....	73
TOWING A DISABLED MACHINE .....	78
OPERATING IN COLD WEATHER .....	81
OPERATING IN HOT WEATHER .....	82
LOADER OPERATION .....	83
BACKHOE OPERATION .....	89

WHEELS/TIRES .....	111
LUBRICATION / MAINTENANCE CHARTS .....	115
GENERAL SAFETY BEFORE YOU SERVICE .....	115
ENGINE HOURMETER .....	115
SUPPORT STRUT FOR LOADER LIFT ARMS .....	116
FLUIDS AND LUBRICANTS .....	117
LUBRICATION/MAINTENANCE CHART .....	118, 119
SYSTEMGARD LUBRICATION ANALYSIS PROGRAM .....	120
ENVIRONMENT .....	120
LUBRICATION/FILTERS/FLUIDS .....	121
OPENING THE ENGINE HOOD .....	121
LOADER GREASE FITTINGS .....	122
BACKHOE GREASE FITTINGS .....	124, 126, 128
FLUID LEVELS .....	133
AMBIENT AIR TEMPERATURE RANGES .....	135
ENGINE OIL RECOMMENDATIONS .....	135
ENGINE SERVICE SPECIFICATIONS .....	136
AIR FILTER SYSTEM .....	139
ENGINE COOLING SYSTEM .....	143
DIESEL FUEL SYSTEM .....	146
HYDRAULIC SYSTEM .....	150
TRANSMISSION .....	153
REAR AXLE .....	155
FRONT FOUR WHEEL DRIVE AXLE .....	158
CAB AIR FILTER .....	160
MAINTENANCE AND ADJUSTMENTS .....	163
LOADER RETURN-TO-DIG ADJUSTMENT .....	163
ETHER STARTING AID .....	164
FAN DRIVE BELT REPLACEMENT .....	165
PLASTIC AND RESIN PARTS .....	165
SPARK ARRESTER MUFFLER (IF EQUIPPED) .....	166
RIDE CONTROL ACCUMULATOR .....	167
CAB AIR CONDITIONING .....	168
ROLL-OVER PROTECTIVE STRUCTURE .....	169
FIRE EXTINGUISHER .....	173
ELECTRICAL SYSTEM .....	175
BATTERIES .....	175
LAMP REPLACEMENT .....	177
INSTRUMENT CLUSTER .....	179
FUSES .....	180

MACHINE STORAGE .....	181
REMOVAL FROM STORAGE .....	182
SPECIFICATIONS .....	183
TABLE OF CONTENTS .....	183
580L SPECIFICATIONS .....	183
ENGINE DATA - 580L .....	183
BOLT TORQUES .....	183
MAIN RELIEF VALVE PRESSURES - 580L .....	184
TRAVEL SPEEDS - 580L .....	184
OPERATING WEIGHTS - 580L .....	184
LOADER BUCKETS - 580L .....	185
BACKHOE BUCKETS - 580L .....	185
BASIC MACHINE DIMENSIONS - 580L .....	186
LOADER OPERATING DATA AND DIMENSIONS - 580L .....	187, 188
BACKHOE OPERATING DATA AND DIMENSIONS - 580L .....	190
BACKHOE LIFT CAPACITY - 580L .....	192
BACKHOE LIFT CAPACITY - 580L (2WD) .....	194
EXTENDAHOE OPERATING DATA AND DIMENSIONS - 580L .....	196
EXTENDAHOE LIFT CAPACITY - RETRACTED 580L .....	198
EXTENDAHOE LIFT CAPACITY - EXTENDED 580L .....	200
EXTENDAHOE LIFT CAPACITY - 580L (2WD) .....	202, 204
SPECIFICATIONS - 580 SUPER L .....	207
ENGINE DATA - 580 SUPER L .....	207
BOLT TORQUES .....	207
MAIN RELIEF VALVE PRESSURES - 580 SUPER L .....	207
TRAVEL SPEEDS - 580 SUPER L .....	208
OPERATING WEIGHTS - 580 SUPER L .....	208
LOADER BUCKETS - 580 SUPER L .....	209
BACKHOE BUCKETS - 580 SUPER L .....	209
BASIC MACHINE DIMENSIONS - 580 SUPER L .....	210
LOADER OPERATING DATA AND DIMENSIONS - 580 SUPER L .....	211, 212
BACKHOE OPERATING DATA AND DIMENSIONS - 580 SUPER L .....	214
BACKHOE LIFT CAPACITY - 580 SUPER L .....	216
BACKHOE LIFT CAPACITY - 580 SUPER L (2WD) .....	218
EXTENDAHOE OPERATING DATA AND DIMENSIONS - 580 SUPER L .....	220
EXTENDAHOE LIFT CAPACITY - RETRACTED 580 SUPER L .....	222
EXTENDAHOE LIFT CAPACITY - EXTENDED 580 SUPER L .....	224
EXTENDAHOE LIFT CAPACITY - 580 SUPER L (2WD) .....	226, 228
SPECIFICATIONS - 590 SUPER L .....	231
ENGINE DATA - 590 SUPER L .....	231
BOLT TORQUES .....	231
MAIN RELIEF VALVE PRESSURES - 590 SUPER L .....	231
TRAVEL SPEEDS - 590 SUPER L .....	232
OPERATING WEIGHTS - 590 SUPER L .....	232
LOADER BUCKETS - 590 SUPER L .....	233
BACKHOE BUCKETS - 590 SUPER L .....	233

BASIC MACHINE DIMENSIONS - 590 SUPER L .....	234
LOADER OPERATING DATA AND DIMENSIONS - 590 SUPER L .....	235, 236
BACKHOE OPERATING DATA AND DIMENSIONS - 590 SUPER L .....	238
BACKHOE LIFT CAPACITY - 590 SUPER L .....	240, 242
EXTENDAHOE OPERATING DATA AND DIMENSIONS - 590 SUPER L .....	244
EXTENDAHOE LIFT CAPACITY - RETRACTED 590 SUPER L .....	246
EXTENDAHOE LIFT CAPACITY - EXTENDED 590 SUPER L .....	248
EXTENDAHOE LIFT CAPACITY - 590 SUPER L .....	250, 252
 AFTER DELIVERY CHECK.....	 255, 257
 ALPHABETICAL INDEX .....	 259

## TO THE OWNER

This manual contains important information about the safe operation, adjustment, service and maintenance of your Case machine. Do not operate or permit anyone else to operate or service this machine until you or the other persons have read this manual. Use only trained operators who have demonstrated the ability to operate and service this machine correctly and safely.



This machine, with standard attachments and equipment, is intended to be used for below ground level digging and general earthmoving purposes, such as trenching, truck loading, and material rehandling.

If the backhoe is to be used to lift loads, for safety purposes it is recommended that the machine is properly equipped. Contact your Case dealer and install a "Load Holding Control Device" on your machine's boom cylinders. This system prevents the sudden lowering of the load in the event of a failure of a hydraulic hose, line, or fitting in the boom hydraulic system. Such a failure can cause personal injury or death. Read "Lifting with the Backhoe" in this manual and follow the instructions and safety precautions. See page 103.

Do not use this machine for any application or purpose other than those described in this manual. Unauthorized modifications can cause serious injury or death. Anyone making such unauthorized modifications is responsible for the consequences.

This operator's manual is to be stored in the compartment in front of the steering wheel and is attached with a lanyard. Make sure this manual is complete and in good condition. Contact your Case dealer to obtain additional manuals.

Contact your authorized Case dealer for any further information about this machine. Your Case dealer has genuine Case parts and service which is your guarantee of Quality and Performance.

Case Corporation  
Racine, WI, U.S.A.

### AFTER DELIVERY CHECK

Two copies of the After Delivery Check are in the back of this manual. One copy is for you and one copy is for the dealer. Make sure that your dealer does the After Delivery Check after the first 20 hours of machine operation.

**NOTE:** Your cost for this inspection will be for filters, oil, or other accessories. If the dealer comes to your machine, there can also be a cost for the time and distance.

### RIGHT, LEFT, FRONT AND REAR OF MACHINE

Right-hand and left-hand, front, and rear, when used in this manual, indicate the right and left sides of the machine as seen from the operators seat.

#### Backhoe

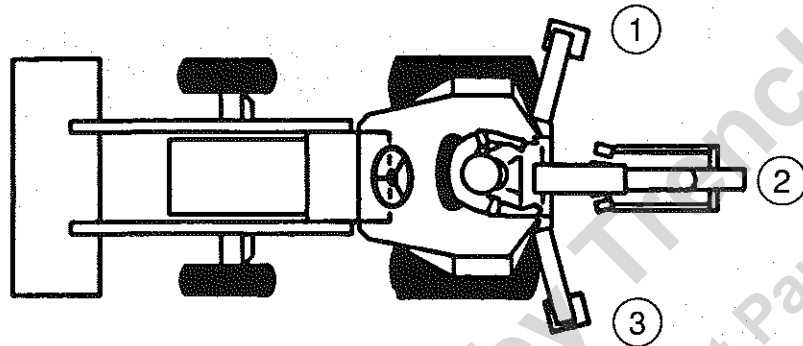

1. Left-Hand      2. Front      3. Right-Hand

B890917J

#### Basic Machine and Loader

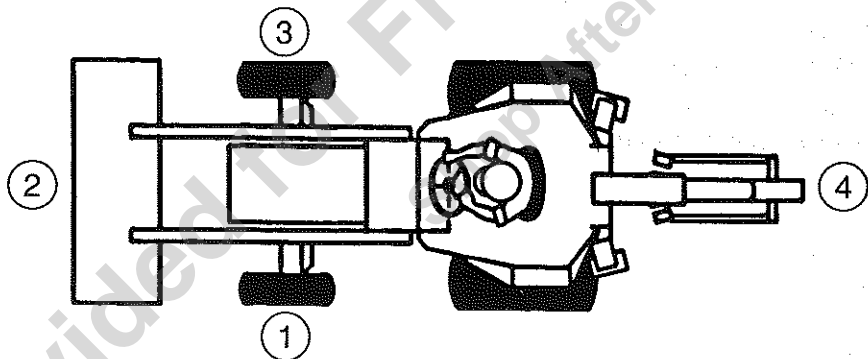

1. Left-Hand      2. Front      3. Right-Hand      4. Rear

B890918J

### IDENTIFICATION NUMBERS

Write the Product Identification Number (P.I.N.) and the engine serial number on the lines provided below. If needed, give these numbers to your Case dealer when you need parts or information for your machine. Keep a record of these numbers and your Manufacturers Statement of Origin in a safe place. If the machine is stolen, report the numbers to your local law enforcement agency.

MACHINE MODEL NUMBER \_\_\_\_\_

PRODUCT IDENTIFICATION NUMBER \_\_\_\_\_

ENGINE SERIAL NUMBER \_\_\_\_\_

ROPS CAB \_\_\_\_\_

ROPS CANOPY \_\_\_\_\_

TRANSMISSION \_\_\_\_\_

REAR AXLE \_\_\_\_\_

FRONT DRIVE AXLE \_\_\_\_\_

(Four Wheel Drive Machines) \_\_\_\_\_

4-IN-1 LOADER BUCKET (Part Number) \_\_\_\_\_

STANDARD LOADER BUCKET (Part Number) \_\_\_\_\_

BACKHOE BUCKET (Part Number) \_\_\_\_\_

#### P.I.N.

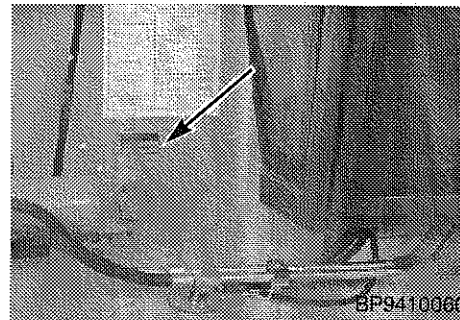

#### Engine Serial Number

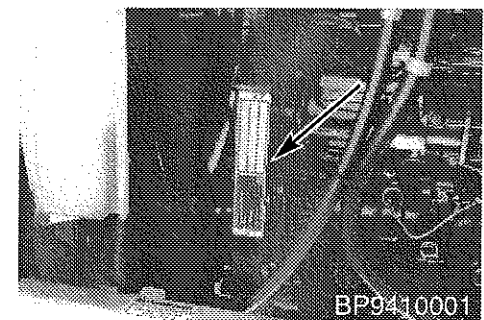

**ROPS Cab**

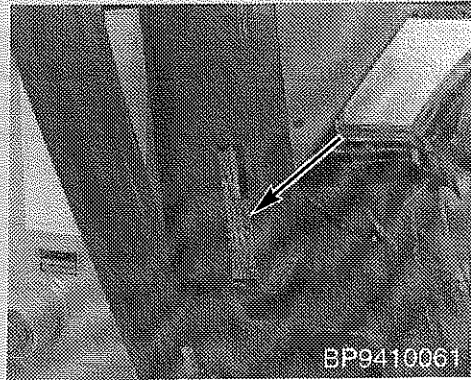

**ROPS Canopy**

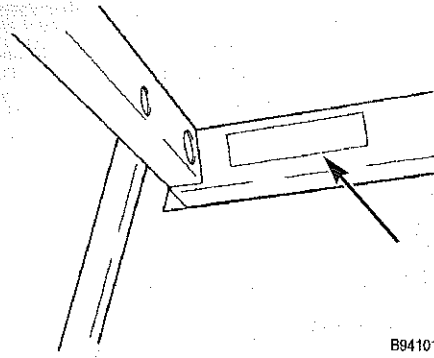

**Front Drive Axle  
(Four Wheel Drive Machines)**

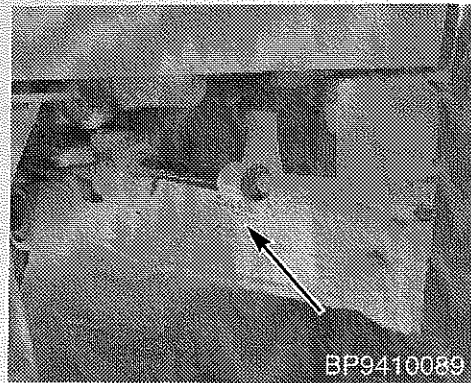

**Transmission**

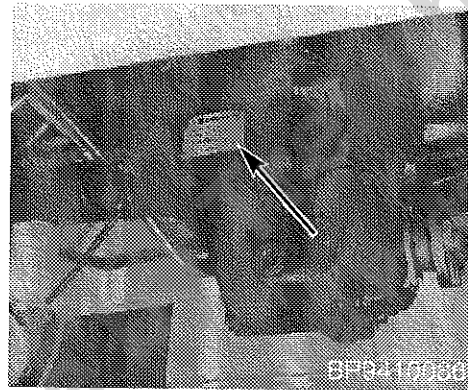

**Rear Axle**

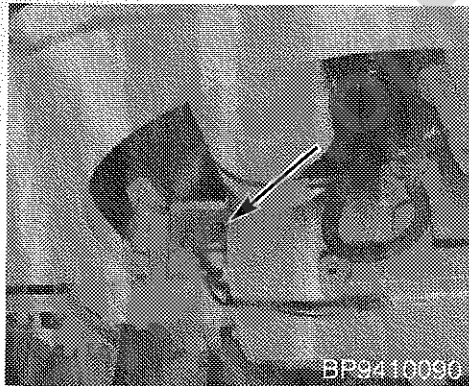

**4-In-1 Loader Bucket  
(Part Number)**

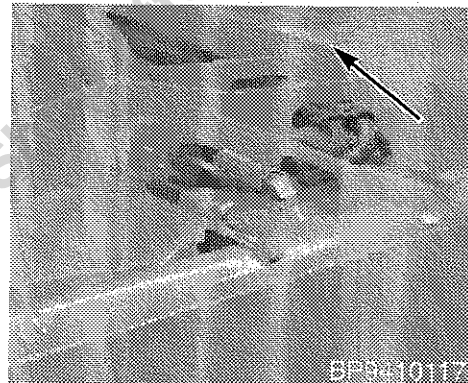

**Backhoe Bucket  
(Part Number)**

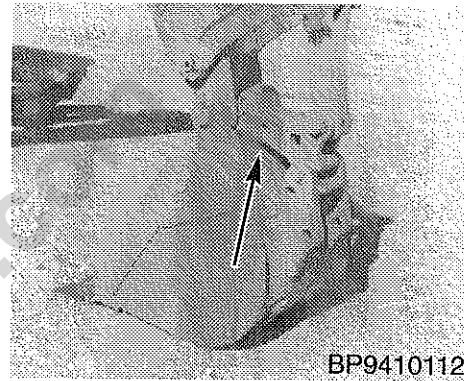

**Standard Loader Bucket  
(Part Number)**

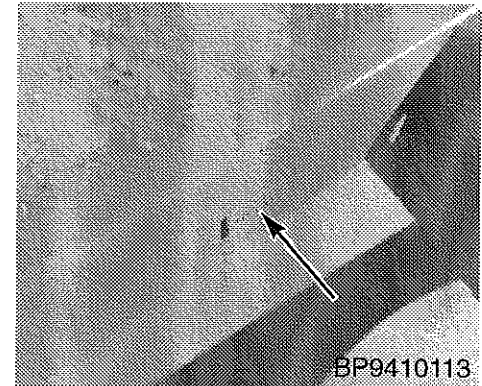

### MACHINE COMPONENTS

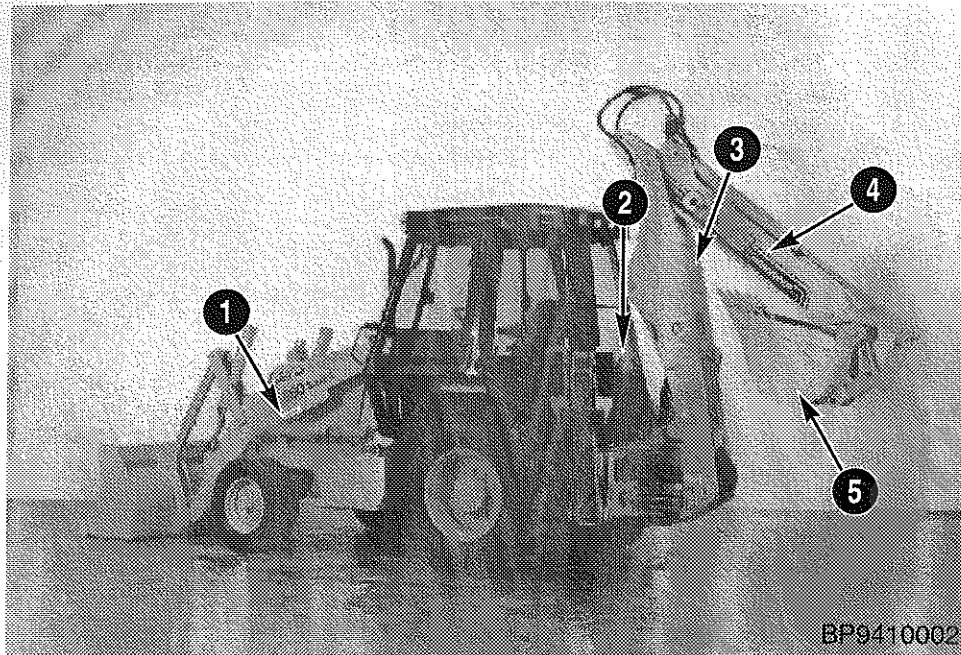

BP9410002

1. Lift Arm Support Strut  
2. Backhoe Controls

3. Boom  
4. Extendable Dipper

5. Backhoe Buckets

### MACHINE COMPONENTS (Cont'd)

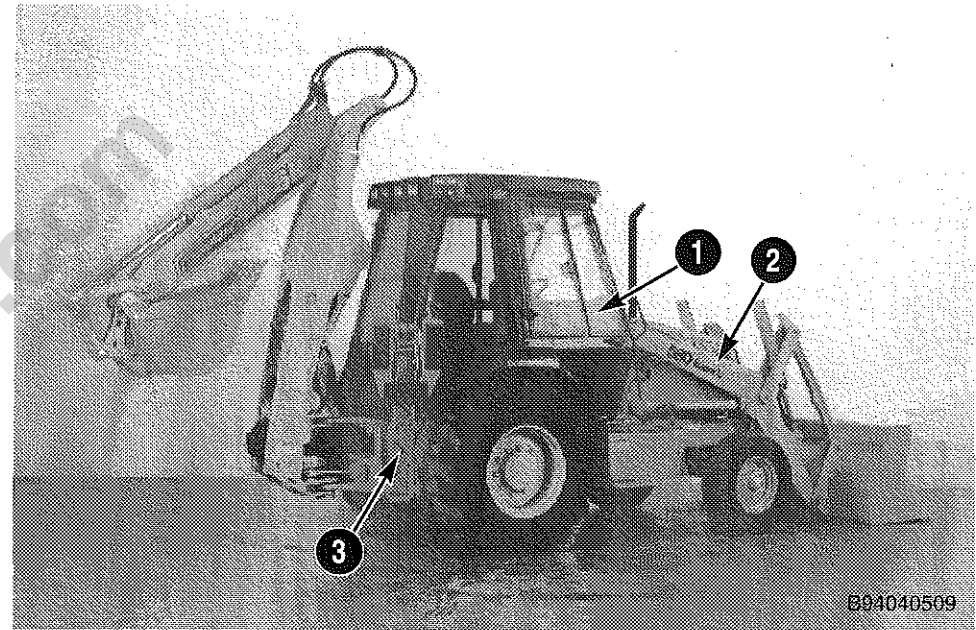

B94040509

1. Loader Controls

2. Loader Lift Arms

3. Stabilizer

### MACHINE COMPONENTS (Cont'd)

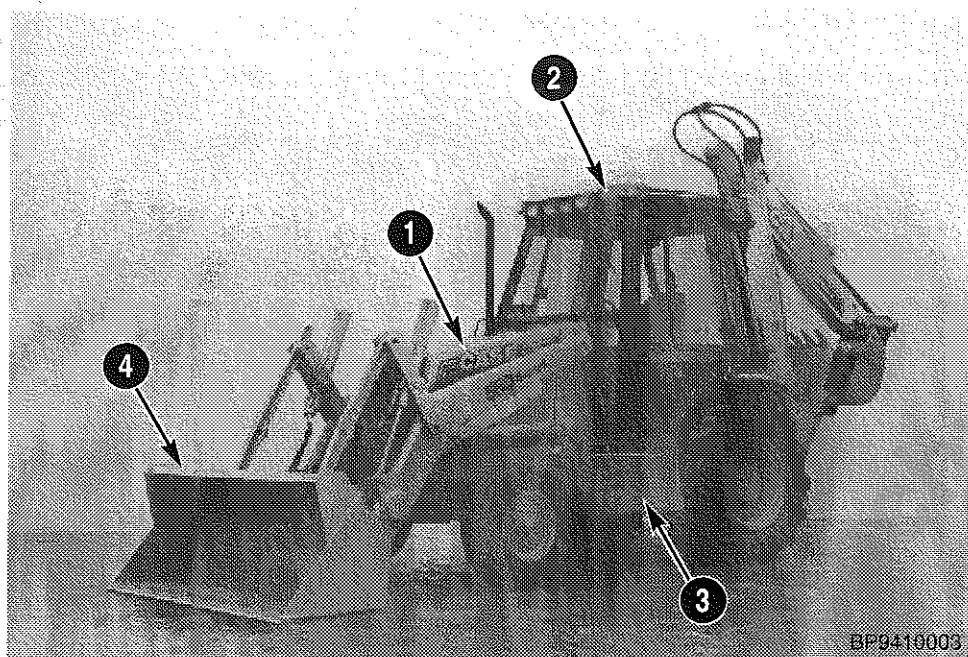

1. Engine Hood  
2. ROPS Cab  
3. Fuel Tank and Step  
4. Standard Loader Bucket

BP9410003

### MACHINE COMPONENTS (Cont'd)

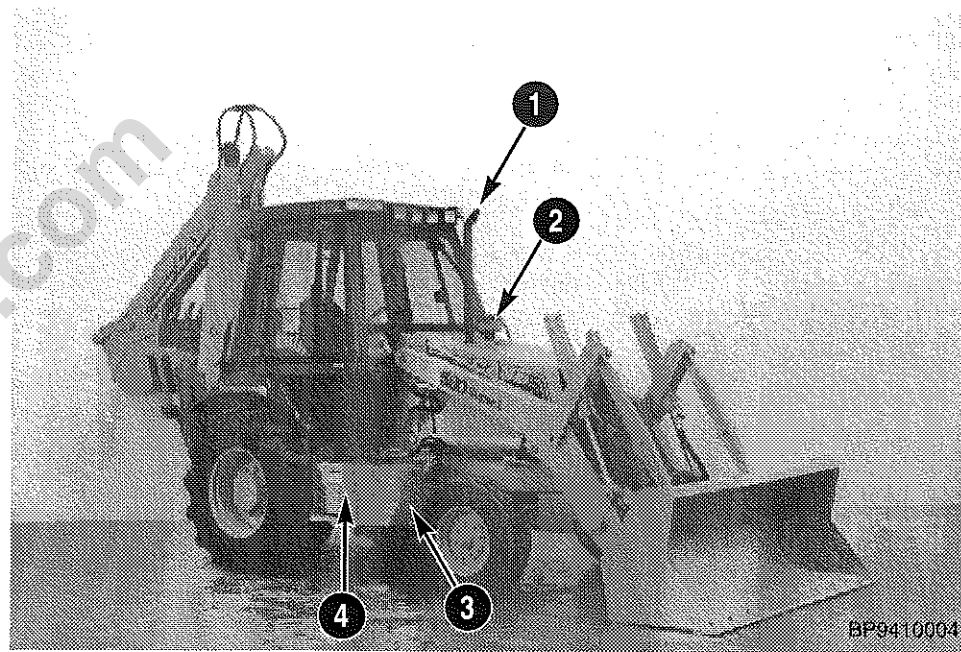

1. Exhaust Pipe  
2. Air Intake  
3. Hydraulic Tank  
4. Battery Box

BP9410004

Provided for Free by  
Shop Aftermarket Parts  
well.com

This page left blank

## SAFETY / DECALS / HAND SIGNALS



### SAFETY RULES



Most accidents involving machine operation and maintenance can be avoided by following basic rules and precautions. Read and understand all the safety messages in this manual, the EMI Safety Manual, and the safety decals on the machine before you operate or service the machine. See your Authorized Case dealer or the Case Corporation if you have any questions.

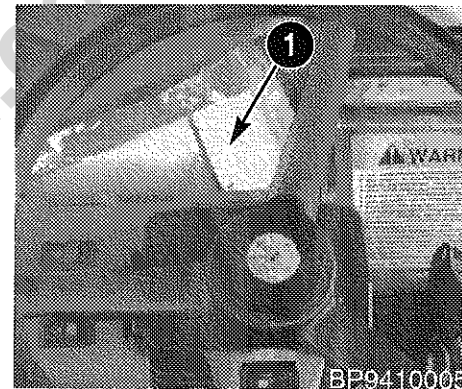

1. Operator's Manual Storage

Safety messages in this section point out situations which can be encountered during the normal operation and maintenance of your machine. These safety messages also give possible ways of dealing with these conditions.

Additional safety messages appear in the manual to indicate specific safety hazards.

**READ THIS MANUAL COMPLETELY** and make sure you understand the characteristics of speed, stability, steering, and operation of this machine.

Do not remove this manual or the safety manual from this machine. See your Case dealer for additional manuals. Also see the inside of the rear cover of this manual for detailed information for ordering manuals.

The safety information given in this manual does not replace safety codes, insurance regulations, or federal, state/provincial, or local laws. Make sure your machine has the correct equipment according to these rules or laws.



## BEFORE OPERATION



- Avoid loose fitting clothing, loose or uncovered long hair, and jewelry.
- Different jobs will require different protective equipment. Items such as hard hats, protective shoes, heavy gloves, reflector type vests, respirators, ear protection, and eye protection can be required. Before you start the job, determine what protective equipment is required. Use this equipment at all times.
- Be prepared for emergencies. Always have a first aid kit and a working fire extinguisher with you and know how to use each. See page 173 for fire extinguisher inspection, service, etc.
- Know the hand signals used on your job. Follow the instructions of the flagman, signs, etc. See pages 30 through 33.
- Check that all doors, guards, and covers are installed correctly or closed.
- Foreign material or grease on the steps and hand rails can cause an accident. Keep the steps and hand rails clean.
- To avoid falling, always face the machine and use the hand rails and steps when getting on or getting off. Do not rush.

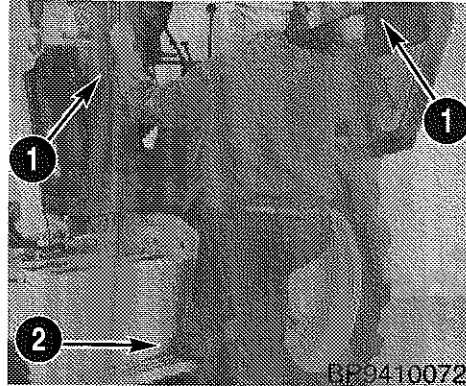

1. Hand Rails 1. Steps

- Remove all loose objects from the cab. Loose objects can jam controls and cause accidents.
- Before you start each day, walk around the machine and check for oil or fluid leaks. Replace all broken or missing parts and do the required lubrication and maintenance as shown in this manual. Clean all trash and debris from the machine, especially from the engine area.
- Make sure all persons are away from the machine before you start the engine.
- Before you start the engine, always fasten the seat belt.

- Before you operate at night, check that all lamps illuminate.
- The secondary exit on machines with a cab is the door on the right side of the cab. Always lower the loader to the ground before exiting the machine.
- Engine exhaust fumes can cause death. If you operate this machine in an enclosed area, make sure there is ventilation to replace the exhaust fumes with fresh air.
- Know the rules, laws, and safety equipment necessary for transporting this machine on a road or highway.
- If your machine has a cab make sure that all windows are clean and that the windshield wipers work correctly.



## MACHINE OPERATION



- Check all controls in a clear area and make sure the machine is operating correctly.
- Do not allow other persons to ride on the machine. Other persons can fall or can cause an accident. This is a one person machine with one operator's seat.
- Dust, fog, smoke, etc., can decrease your vision and cause an accident. Stop the machine or decrease the speed until you can see everything around you in the work area. Make sure the machine lamps are ON.
- Contact with high voltage power lines, underground cables, etc., can cause serious injury or death from electrocution.

Before you drive or operate in an area with high voltage lines, cables, or a power station, tell the power or utility company what you are going to do. You **MUST HAVE THE POWER DISCONNECTED OR KEEP A SAFE WORKING DISTANCE** from the lines, cables, or powerstation. Keep all parts of the machine at least 4.6 m (15 feet) away from the power source. You must also know any federal, state/provincial, or local safety codes or regulations that apply to the job site.

If a part of the machine touches high voltage power:

1. Warn other workers **NOT TO TOUCH THE MACHINE** and to stay away from the machine.

2. If you can break contact, reverse the operation that caused contact with the high voltage power, and move the machine away from the danger area. If you cannot break contact, stay in the machine until the utility company de-energizes the line and tells you that the power is off.

3. If you have extreme conditions, such as a fire, etc., and you are forced to leave the machine, do not step off the machine. Jump as far from the machine as possible with your feet together and do not touch the ground with your hands.

4. Then, hop away with your feet together until you are a safe distance from the machine and the electrical current. Do not take large steps. Because of the voltage differential across the ground, one foot can be in a higher voltage area than the other foot. This difference can kill you.

- Do not operate the machine if you do not feel well. This can be dangerous for you and for the people around you.
- You must make a judgment if weather, road, or earth conditions will permit safe operation on a hill, ramp, or rough ground.
- Stay away from hazardous areas such as ditches, overhangs, etc. Walk around the work area before you start and look for hazards.
- Be alert and always know the location of all workers in your area. Keep all other persons completely away from your machine. Injury or death can result if you do not follow these instructions.

- Keep the loader bucket low when moving around the work area and be careful when you raise the load to dump.
- Operate the machine within the specified capacities and limits. Lifting capacities, digging depths, etc, are shown in the Specifications section of this manual.
- Operate the machine controls from the operators seat only.
- Digging through underground cables, pipes, lines, etc., can cause injury or death. Learn the location of all underground hazards before you operate your machine in any area.

- When working in areas where traffic is heavy always have a person direct the traffic and direct other persons for you. Have guard rails, warning signs, etc., as required for your job.
- Stop operating the machine if a malfunction occurs. Watch the indicator and warning lamps in the machine. Listen and smell for things that are not normal on your machine.
- Drive around large objects such as large rocks or trees.

**PARKING THE MACHINE**

- When you park the machine and before you leave the operators area, always support or lower all attachments (loader, backhoe, etc.) to the ground, apply the parking brake, stop the engine, and remove the key.
- Follow the instructions in this manual for "Parking the Machine".
- If you must temporarily park the machine on a hillside, put the front of the machine toward the bottom of the hill. Make sure the machine is behind an object that will not move. Put blocks in front of each wheel on the downhill side.
- Always face the machine and use the hand rails and steps when getting off. Do not rush and do not jump from the machine.

**BURN PREVENTION**

- Batteries contain sulfuric acid which can cause severe burns. Avoid contact with skin, eyes, or clothing. Antidote - EXTERNAL: flush with water. INTERNAL: drink large quantities of water or milk. Follow with milk of magnesia, beaten egg or vegetable oil. Call a doctor immediately. EYES: flush with water for 15 minutes and get prompt medical attention.
- When the battery electrolyte is frozen, the battery can explode if, (1) you try to charge the battery, or (2) you try to jump start and run the engine. To prevent the battery electrolyte from freezing, keep the battery at full charge. If you do not follow these instructions, you or others in the area can be injured.
- Hot coolant can spray out if the radiator cap is removed too quickly. To remove the radiator cap, let the cooling system cool, turn the cap to the first notch, wait until the pressure is released, then remove the cap.

**FIRE OR EXPLOSION PREVENTION**

- Sparks or flame can cause the hydrogen gas in a battery to explode. To prevent an explosion, do the following:
  1. When disconnecting the battery cables, disconnect the negative (-) cable first; when connecting the battery cables, connect the negative (-) cable last.
  2. When connecting jumper cables to start the engine, use the procedure shown in this manual on page 71.
  3. Do not short circuit the battery posts with metal items.
  4. Do not weld, grind, or smoke near a battery. Keep open flame away from the battery.
- Sparks from the electrical system or engine exhaust can cause an explosion or fire. Before you operate this machine in an area with flammable dust or vapors, use good ventilation to remove the flammable dust or vapors before you start.
- Engine fuel can cause an explosion or fire. Do not fill the fuel tank while the engine is running.
- DO NOT smoke while refueling the machine.
- Use nonflammable cleaning solvent to clean parts.
- A fire can cause injury or death. Always have a fire extinguisher near or on the machine. Make sure the fire extinguisher is serviced according to the manufacturer's instructions.
- If a fire extinguisher has been used, always recharge or replace the fire extinguisher before operating the machine. See page 173.
- Remove all trash or debris from the machine as required. Especially check the engine area and exhaust system.
- If the machine has an oil, fuel, or hydraulic leak, always repair the leak and clean the area before operating.
- Keep the cooling system clean and maintain the correct coolant level.
- Make sure that you do not store oily rags or other flammable materials on the machine.
- Starting fluid (ether) can explode and can cause injury or death. Do not breathe starting fluid vapors. Wear face protection when you remove or install a starting fluid container or when you use an aerosol spray starting fluid. Use starting fluid according to the instructions in this manual on pages 69 and 70.
- If you weld, grind, or use a cutting torch on the machine, always remove the starting fluid container from the machine. Use compressed air to remove any ether fumes from the area.
- Before welding or using a torch on the machine, clean the area to be repaired.
- Check the electrical system for loose connections or frayed insulation. Repair or replace the loose or damaged parts.

**MAINTENANCE**

- Before you service the machine, put a Do Not Operate tag on the steering wheel. One Do Not Operate tag is included with your new machine. Additional tags, part number 321-4614, are available from your Case dealer.
- If you must service this machine with the engine running, have another person help you. Follow the instructions in this manual or the service manual. Do not leave the operator's seat while the engine is running.
- Disconnect the batteries before working on the electrical system.
- If you are exposed to or come in contact with hazardous chemicals you can be seriously injured. The fluids, lubricants, paints, adhesives, coolants, etc., used with your machine can be hazardous.

<b>DO NOT OPERATE</b>
Reason _____
_____
_____
Signed by _____

<b>DO NOT REMOVE THIS TAG!</b>
See Other Side
<b>CASE CORPORATION</b>
Case Part No. 321-4614 Printed in U.S.A.

B9502062

- Improper service or repair procedures can cause injury or death. If you do not understand a service or adjustment procedure, see the service manual for this machine or see your Case dealer.
- Unauthorized modifications to this machine can cause injury or death. Do not make unauthorized modifications to this machine. Always see your Case dealer before you weld, cut, or drill holes in your machine.

Material Safety Data Sheets (MSDS) provide (1) information about the chemical substances within a product, (2) safe handling procedures, (3) first aid measures, and (4) procedures to be taken when the product is accidentally spilled or released. Material Safety Data Sheets (MSDS) are available from your Case dealer.

Before you service your machine, check the MSDS for each fluid, lubricant, etc., used in this machine. This information indicates what the risks are and how to service the machine safely. Follow this information when servicing the machine.

- Before you service this machine and before you dispose of the old fluids and lubricants, always remember the environment. Do not put oil or fluids into the ground or into containers that can leak.

Check with your local environmental or recycling center or your Case dealer for correct disposal information.

- When you service this machine, always wear face or eye protection, safety shoes, and other protective items as required.
- Metal chips or debris can cause eye injury. Always wear eye or face protection when you use a hammer on this machine. Use a hammer with a soft face, such as brass, to drive hardened pins.

- Lower the bucket or tool to the ground or block up the machine securely before working on the machine. Follow the instructions in this manual when you service the machine.
- Clean the machine regularly. A build-up of grease, dirt, and debris can cause possible injury or machine damage. Keep your work shop clean.
- Before welding on this machine, disconnect the battery ground (-).
- Fluids such as Gasoline, Kerosene, Diesel Fuel, Hydraulic Oil, etc. contain chemicals that can be dangerous to your health and can cause cancer and/or birth defects. Contact either internally or externally can cause infection or other injury. If any internal or external contact occurs, see your local Poison Control Center or doctor IMMEDIATELY.

**WHEELS AND TIRES MAINTENANCE**

- Do NOT weld to wheel or rim when a tire is installed. Welding will cause an explosive air/gas mixture that will be ignited with high temperatures. This can happen to tires inflated or deflated. Removing air or breaking bead is not adequate. Tire MUST be completely removed from the rim prior to welding.
- Explosive separation of the tire and/or rim parts can cause injury or death. When tire service is necessary, have a qualified tire mechanic service the tire.

**ROLL-OVER PROTECTIVE STRUCTURE**

- Do not modify ROPS in any manner. Unauthorized modifications such as welding, drilling, cutting, or adding attachments can weaken the structure and reduce your protection. Replace ROPS if it is subjected to roll-over or damage. Do not attempt to repair.

**CAST DUCTILE IRON**

- Before you weld, cut, or drill holes in a part on this machine, make sure the part is not cast ductile iron. See your dealer if you do not know if a part is cast ductile iron. Also see the following photograph for cast ductile iron parts.
- Unauthorized modifications to cast ductile iron parts can cause injury or death. Welding, cutting, or drilling can cause cast ductile iron to break. Do not weld, cut, or drill to repair or to attach items to cast ductile iron parts on this machine.

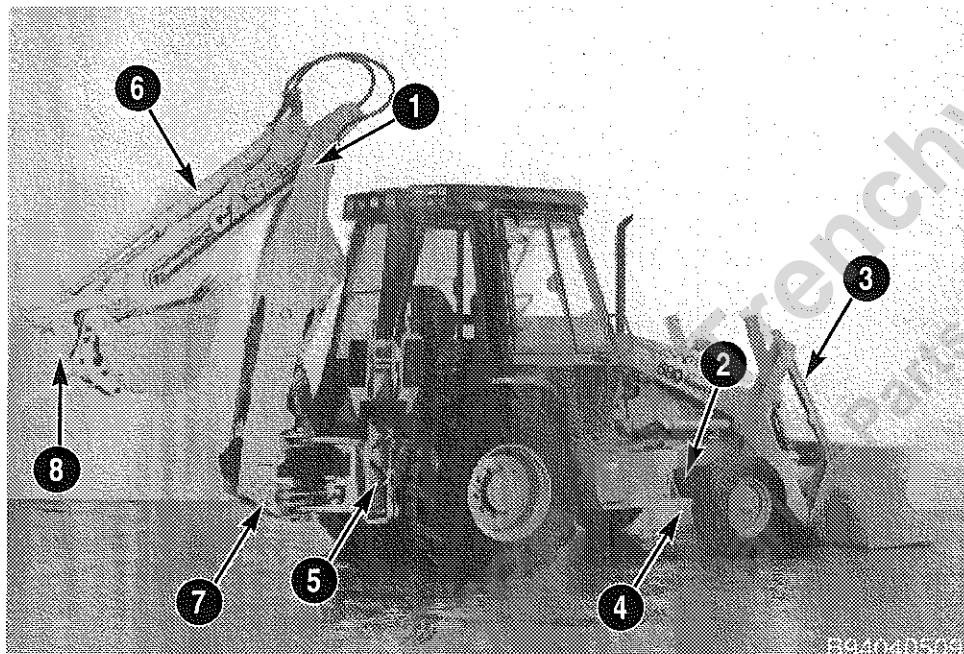

- |                                      |                |                             |
|--------------------------------------|----------------|-----------------------------|
| 1. Boom                              | 4. Front Axle  | 8. Bucket Links and Coupler |
| 2. Steering Links<br>(2 Wheel Drive) | 5. Stabilizers |                             |
| 3. Dump Links                        | 6. Dipper      |                             |
|                                      | 7. Swing Tower |                             |

**SAFETY DECALS**

**WARNING:** Injury or death can result if you cannot read a safety decal or if a safety decal is missing. Replace any missing or damaged safety decal and keep all safety decals clean. See your Case dealer for new safety decals.

SB002

Make sure that you read all the safety decals and all instructional decals. Check these decals every day before you start. Clean these decals if you cannot read the words.

When you clean the decals, use only a cloth, water, and soap. Do not use solvent, gasoline, etc.

You must replace a decal if the decal is damaged, missing, or cannot be read. If a decal is on a part that is replaced, make sure the decal is on the new part. See your Case dealer for new decals.

The following pages show the actual decal and the location of the decal on the machine.

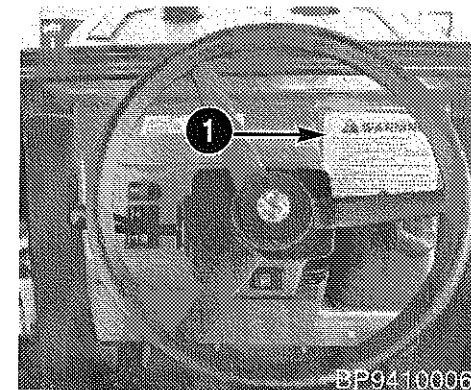

1. 144194A1

**WARNING**

- Walk around and check your machine before starting.
- Dress properly. No loose clothing or jewelry.
- Clear the area of all persons. Know their location.
- Check that all controls are in neutral before starting.
- Have seat in locked position and fasten seat belt before starting.
- Learn and practice safe use of controls. Operate from seat position only.
- Do not permit riders on any part of machine.
- Lock brake pedals together for road travel.
- Be aware of surroundings, persons, obstructions and overhead wires.
- Keep bucket(s) or attachments as low as possible. On hill and uneven terrain use lower gears and drive slowly.
- Lower attachments to ground or support them before leaving machine.
- Park on level ground, apply parking brake, stop engine, remove key.
- Face the machine, use handrails, supports and steps entering and exiting.
- The right hand exit is a secondary exit only to be used when necessary.
- Make sure operators area is clean and free of loose items.
- Check instrument warning lights and buzzers before and after starting.

**INCORRECT OPERATION OF THIS MACHINE CAN CAUSE INJURY OR DEATH**

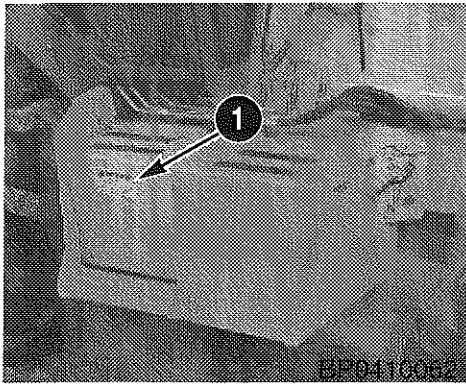

BP9410062

1. 321-6714

**⚠ WARNING**

BATTERIES CONTAIN ACID AND EXPLOSIVE GAS. EXPLOSION CAN RESULT FROM SPARKS, FLAMES, OR WRONG CABLE CONNECTIONS. TO CONNECT JUMPER CABLES OR CHARGER, SEE MANUAL(S) FOR THE CORRECT PROCEDURE. FAILURE TO FOLLOW THE ABOVE INSTRUCTIONS CAN CAUSE SERIOUS PERSONAL INJURY OR DEATH.

321-6714

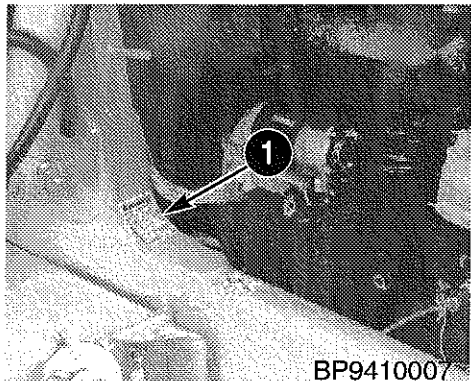

BP9410007

1. 321-6872

**⚠ WARNING**

WRONG JUMPER CABLE CONNECTIONS TO STARTER TERMINALS OR SHORTING ACROSS THE STARTER TERMINALS CAN CAUSE THE MACHINE TO MOVE SUDDENLY OUT OF CONTROL. YOU CAN BE INJURED OR KILLED.

USE THE CORRECT METHOD SHOWN IN THE OPERATOR'S MANUAL TO CONNECT JUMPER CABLES TO START THE ENGINE.

321-6872

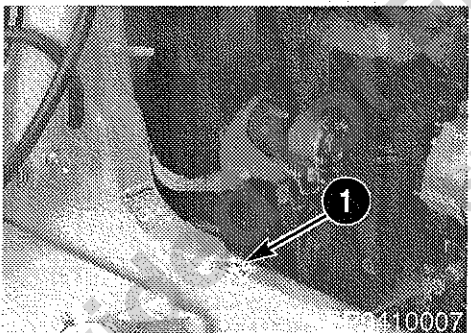

BP9410007

1. 321-7040

**⚠ DANGER**

Starting in gear can cause death. Start engine only from operator seat with transmission control(s) in NEUTRAL.

321-7040

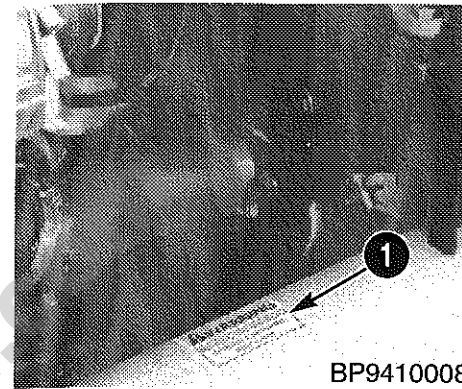

BP9410008

1. 321-3596

**⚠ WARNING**

ROTATING FAN AND BELTS. CONTACT CAN INJURE. KEEP CLEAR.

161/30A1

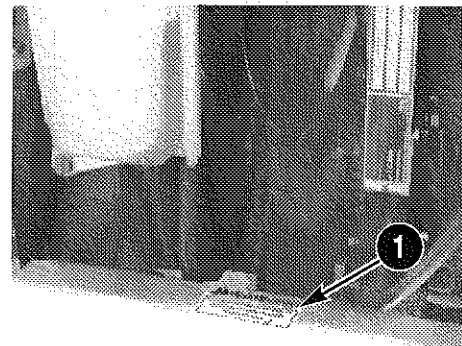

BP9410001

1. 321-3596

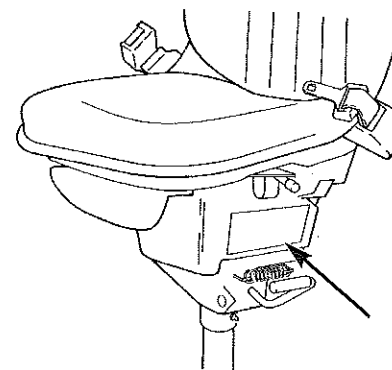

B9410144S

**⚠ WARNING**

THE SPRING IN THIS ASSEMBLY IS COMPRESSED. INCORRECT DISASSEMBLY CAN CAUSE INJURY. SEE SERVICE MANUAL.

B870084J

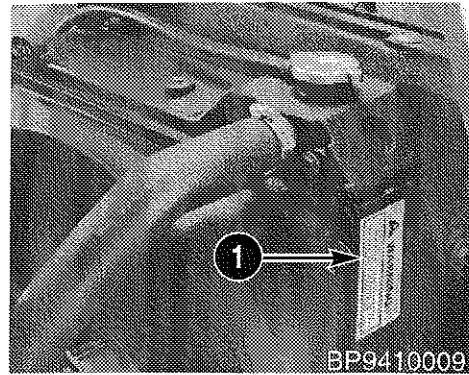

1. 321-6672 - RH

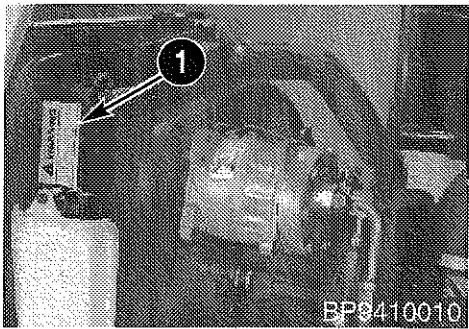

1. 321-6672 - LH

**! WARNING**

CHECK AND SERVICE COOLING SYSTEM ACCORDING TO MAINTENANCE INSTRUCTIONS.  
HOT COOLANT CAN SPRAY OUT IF RADIATOR CAP IS REMOVED.  
TO REMOVE RADIATOR CAP: LET SYSTEM COOL; TURN TO FIRST NOTCH; THEN WAIT UNTIL ALL PRESSURE IS RELEASED.  
SCALDING CAN RESULT FROM FAST REMOVAL OF RADIATOR CAP.

321-6672

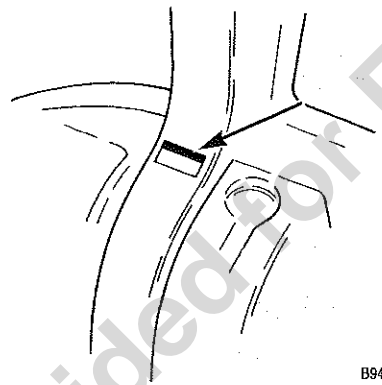

B9410229

**! WARNING**

TO AVOID INADVERTANT MOVEMENT, BEFORE OPERATING THE BACKHOE ALWAYS PLACE THE FOUR SPEED TRANSMISSION AND FORWARD REVERSE CONTROL LEVER IN NEUTRAL AND ENGAGE THE PARKING BRAKE.

D150899

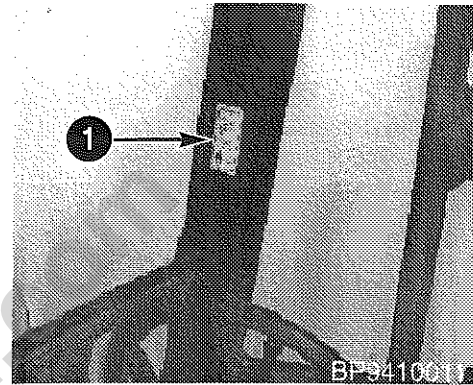

1. 321-7030

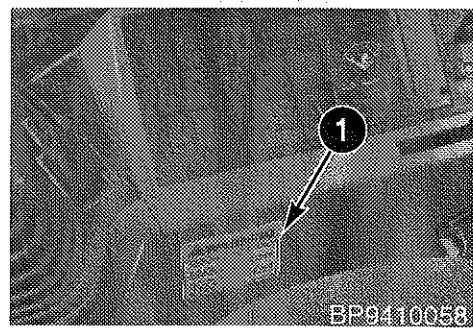

1. D150900

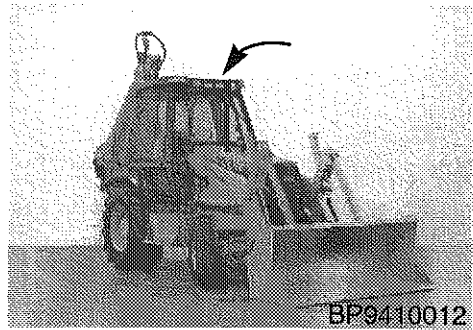

1. 112236A1



321-7030

**! WARNING**

EXCESSIVE SPEED CAN CAUSE LOSS OF MACHINE CONTROL OR MACHINE DAMAGE.  
  
DO NOT COAST DOWN A HILL WITH THE TRANSMISSION IN NEUTRAL OR DO NOT EXCEED 2500 R.P.M. WHEN DRIVING DOWN A HILL.  
  
BEFORE DRIVING DOWN A HILL, SHIFT TO A LOWER GEAR AND DRIVE SLOWLY. YOU OR OTHERS AROUND YOU CAN BE INJURED IF THE MACHINE IS OUT OF CONTROL.

D150900

**! CAUTION**

THIS IS AN INSULATED ROOF SYSTEM  
CONSULT YOUR DEALER BEFORE WELDING ON THE TOP OF THE CAB

112236A1

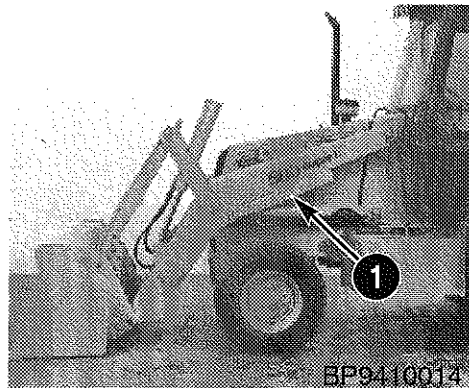

**⚠ WARNING**

IF YOU SERVICE THE MACHINE WITH THE LOADER LIFT ARMS RAISED, ALWAYS USE THE SUPPORT STRUT.

1. EMPTY THE LOADER BUCKET, RAISE THE LOADER LIFT ARMS TO MAXIMUM HEIGHT AND STOP THE ENGINE.
2. REMOVE THE REAR PIN FROM THE SUPPORT STRUT AND LOWER THE SUPPORT STRUT ONTO THE CYLINDER ROD.
3. INSTALL THE REAR PIN IN THE SUPPORT STRUT.
4. SLOWLY LOWER THE LIFT ARMS ONTO THE SUPPORT STRUT.

IF YOU DO NOT FOLLOW THIS PROCEDURE, YOU CAN CAUSE SERIOUS INJURY OR DEATH IF THE LOADER LIFT ARMS ARE LOWERED BY ACCIDENT.

B861734J

1. 321-6413

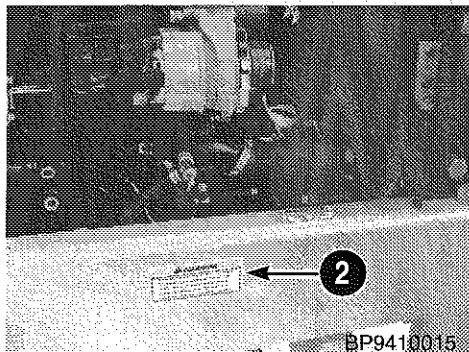

**⚠ WARNING**

IF YOU SERVICE THE MACHINE WITH THE LOADER LIFT ARMS RAISED, ALWAYS USE THE SUPPORT STRUT. FAILURE TO FOLLOW THIS PROCEDURE CAN CAUSE SERIOUS INJURY OR DEATH IF THE LOADER LIFT ARMS ARE LOWERED BY ACCIDENT.

B861732J

1. 321-6671

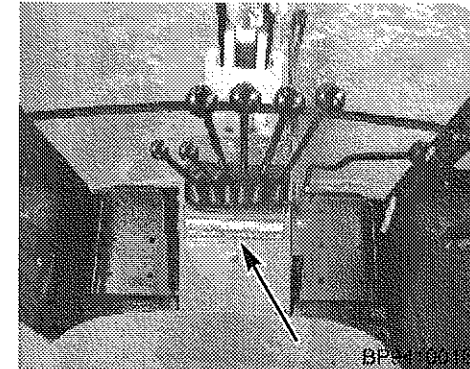

**⚠ CAUTION**

OPERATE BACKHOE FROM SEAT POSITION ONLY. FOR TRANSPORT, USE OVERCENTER POSITION WITH BUCKET STRAIGHT TO REAR.

**IMPORTANT** DUE TO POSSIBLE INTERFERENCE WITH "STABILIZER OR TRACTOR", CAUTION MUST BE USED WHEN SWINGING BOOM TO EXTREME LEFT OR RIGHT POSITION.

D149826

D149826

Standard Backhoe

**⚠ CAUTION**

OPERATE BACKHOE FROM SEAT POSITION ONLY. FOR TRANSPORT, USE OVERCENTER POSITION WITH BUCKET STRAIGHT TO REAR.

**IMPORTANT** DUE TO POSSIBLE INTERFERENCE WITH "STABILIZER OR TRACTOR", CAUTION MUST BE USED WHEN SWINGING BOOM TO EXTREME LEFT OR RIGHT POSITION.

D149827

EXTENDAHOE

D149827

Extendahoe

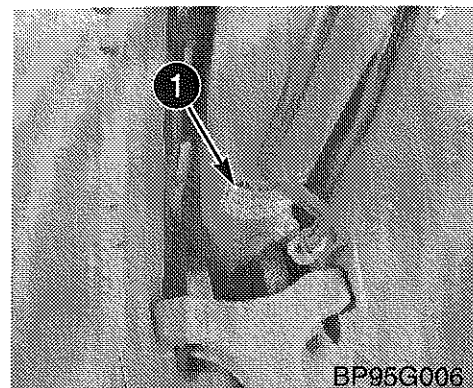

BP95G006

1. 321-6046

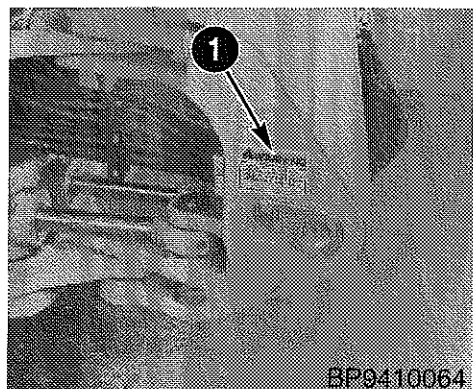

BP9410064

1. 321-4481

## **! WARNING**

**IF YOU USE THE BACKHOE TO LIFT A LOAD THAT IS TOO HEAVY, THE MACHINE CAN TURN OVER OR THE LOAD CAN FALL OUT OF CONTROL.**

**BEFORE YOU LIFT OBJECTS WITH THE BACKHOE, SEE THE OPERATOR'S MANUAL TOPIC**

### **"LIFTING WITH THE BACKHOE"**

**IF YOU DO NOT FOLLOW THESE INSTRUCTIONS, SEVERE INJURY CAN OCCUR TO YOU OR OTHER PERSONS IN THE AREA.**

B861733J

## **! WARNING**

**KEEP CLEAR OF THIS AREA SWINGING BOOM CAN CRUSH. OPERATE BACKHOE FROM OPERATOR'S SEAT ONLY.**

**ANY OTHER METHOD COULD RESULT IN INJURY TO OPERATOR OR BYSTANDERS.**

B861335J

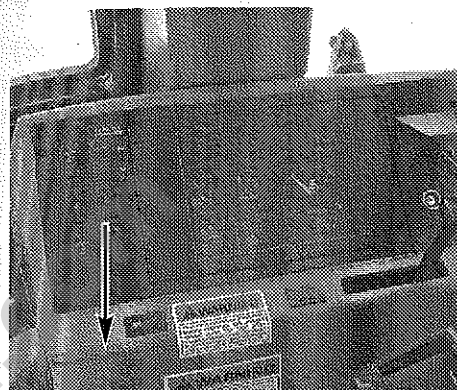

BP96G001

## **! WARNING**

**DO NOT TURN THE RIDE CONTROL ON, IF THE LOADER ARMS AND BUCKET ARE HOLDING THE FRONT OF THE MACHINE OFF THE GROUND. THE MACHINE CAN DROP CAUSING SERIOUS INJURY OR DEATH.**

255927A1

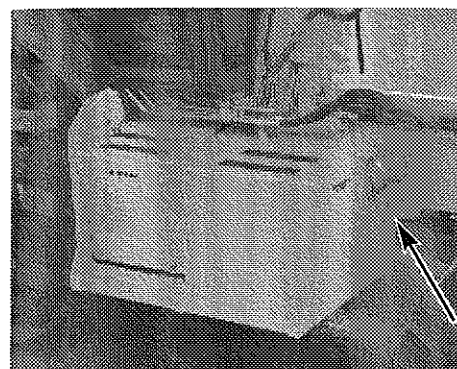

BP9410062

## **! WARNING**

### **PRESSURE ACCUMULATOR IN LOADER HYDRAULIC SYSTEM**

**DISCHARGE HYDRAULIC PRESSURE PRIOR TO DISCONNECTING HYDRAULIC LINES. ESCAPING HYDRAULIC OIL UNDER PRESSURE COULD CAUSE INJURY.**

- REFER TO THE SERVICE MANUAL. PRECHARGE ONLY WITH DRY INERT GAS SUCH AS HIGH PURITY NITROGEN.
- REFER TO THE SERVICE MANUAL. DISCHARGE ALL GAS PRESSURE PRIOR TO DISASSEMBLING THE ACCUMULATOR.

256318A1

### HAND SIGNALS

It is recommended that you and the flagman on the job use hand signals for communications. Before you start, make sure that you both understand the signals that will be used.

#### Start Engine



BS96F234

#### Stop Engine

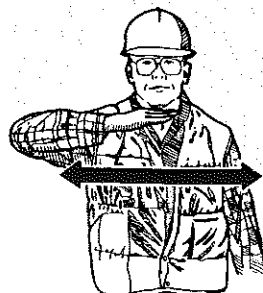

BS96F234

#### Come To Me

Move hand forward and rearward (palms in).



BS96F235

#### Move Away From Me

Move hands forward and rearward, (palms out).



BS96F235

#### Go This Far



BS96F228

#### All Stop and Hold

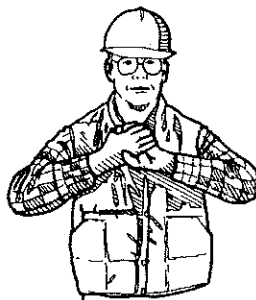

BS96F228

#### Turn Machine Left (Swing Load Left)

To stop movement, stop moving hand and make a fist.

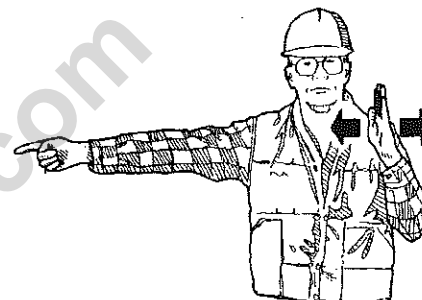

BS96F229

#### Turn Machine Right (Swing Load Right)

To stop movement, stop moving hand and make a fist.



BS96F229

#### Roll Back Loader Bucket

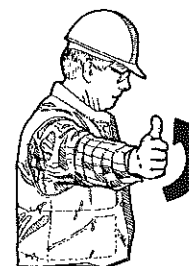

AS110J

#### Dump Loader Bucket

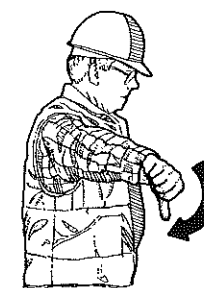

AS110J

#### Raise Backhoe Boom

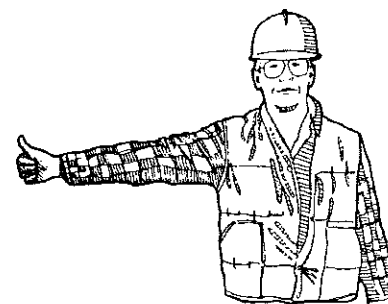

BS96F233

#### Lower Backhoe Boom

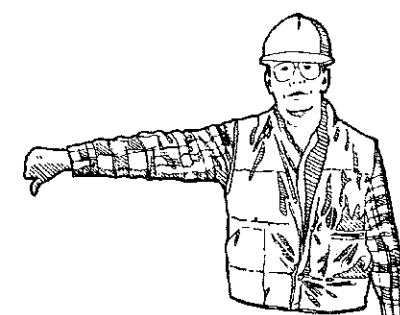

BS96F233

**Stop**

Move one hand back and forth.

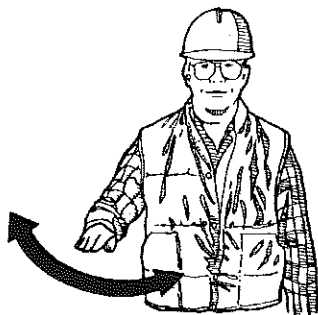

BS96F229

**Emergency Stop**

Move both hands rapidly back and forth.



BS96F229

**Raise Load or Bucket**



BS96F230

**Lower Load or Bucket**

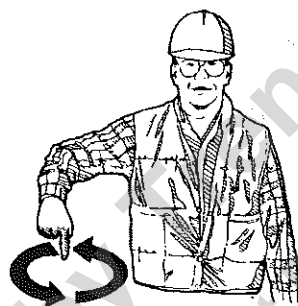

BS96F230

**Raise Load or Bucket Slowly**

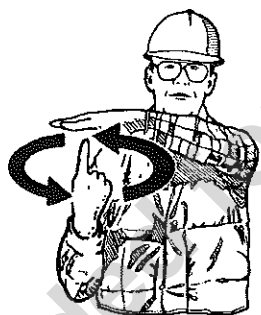

BS96F231

**Lower Load or Bucket Slowly**



BS96F231

**Backhoe Dipper In**

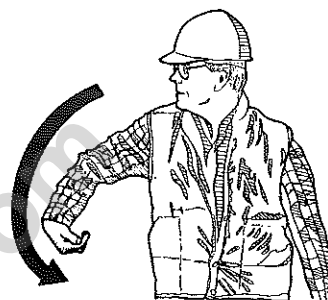

AS106J

**Backhoe Dipper Out**

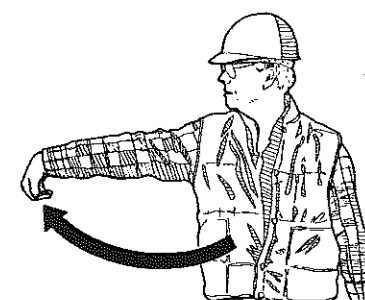

AS106J

**Backhoe Bucket Dig**

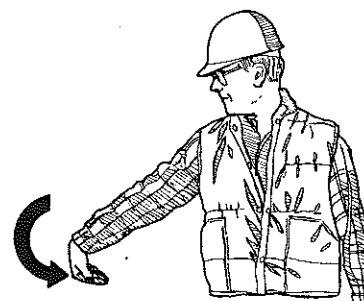

AS107J

**Backhoe Bucket Dump**

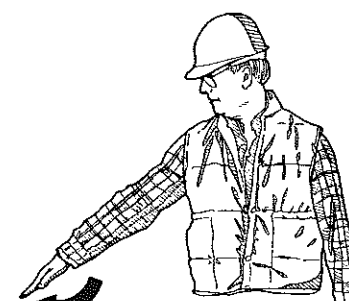

AS107J

**Extendahoe Dipper Retract**

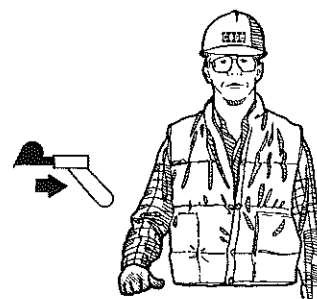

AS108J

**Extendahoe Dipper Extend**

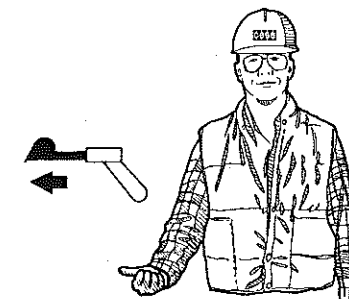

AS108J

This Page Left Blank

## 45 INSTRUMENTS AND CONTROLS

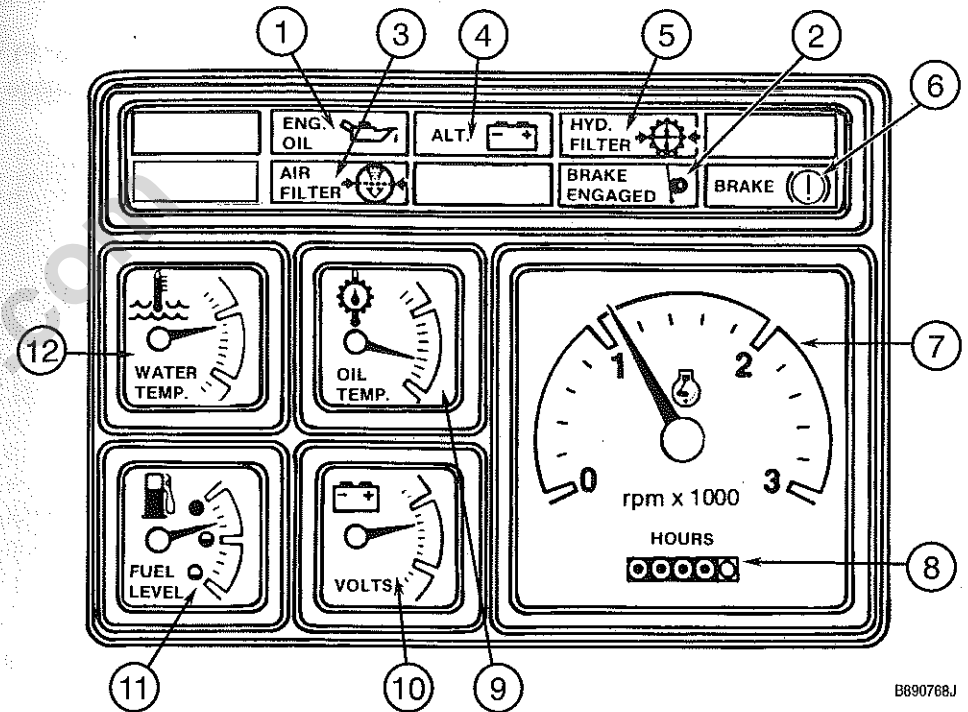

B690766J

1. **WARNING LAMP FOR ENGINE OIL PRESSURE:** This warning lamp illuminates if, (1) the engine is stopped and the key switch is ON, or (2) there is no or low oil pressure in the engine. Do not run the engine if the warning lamp illuminates.
2. **WARNING LAMP FOR PARKING BRAKE:** This warning lamp will illuminate when the key switch is ON and the parking brake is engaged. Do not drive the machine with the parking brake applied.
3. **WARNING LAMP FOR AIR FILTER RESTRICTION:** This warning lamp illuminates when, (1) the key switch is in the START position or (2) the air filter element requires service.
4. **WARNING LAMP FOR ALTERNATOR:** This lamp illuminates if, (1) the engine is stopped and the key switch is ON or (2) the alternator is not charging the batteries.
5. **WARNING LAMP FOR HYDRAULIC FILTER RESTRICTION:** This warning lamp illuminates when, (1) the key switch is in the START position or, (2) the hydraulic filter requires service. Hydraulic fluid must be at operating temperature, see page 150.

6. **WARNING LAMP FOR REAR AXLE OIL TEMPERATURE:** This lamp illuminates when the oil temperature in the rear axle reaches 137°C (305° F). Take action to reduce the temperature until the lamp stops illuminating. See page 155.
7. **TACHOMETER:** The tachometer shows the engine speed in revolutions per minute (rpm). Each number on the gauge is equal to 1000 rpm. Each space on the gauge is equal to 200 rpm. It is recommended that the engine be run in the green area of the gauge.
8. **ENGINE HOURMETER:** This hourmeter shows the hours and tenths of an hour the engine has run.
9. **OIL TEMPERATURE GAUGE (TORQUE CONVERTER):** The normal operating temperature of the converter oil is in the green area of the gauge. If the gauge needle goes into the red area, select a lower transmission speed. If the needle remains in the red area, stop the machine, move the direction control lever to the NEUTRAL position and run the engine at full throttle. If this procedure does not reduce the temperature of the oil, check the oil level and check for obstructions in the radiator and oil cooler.
10. **VOLTMETER GAUGE:** This gauge shows the condition of the battery. The battery condition is normal when the gauge needle is in the green area of the gauge when the key switch is in the ON position. If the gauge needle is in the lower red area, the charge of the battery is too low or the alternator is not charging. If the gauge needle moves into the upper red area, the alternator is charging too much. Damage to the battery can result if this condition continues.
- NOTE:** When the battery is in good condition and you turn the key switch to the ON position, the gauge needle will move up to the bottom part of the green area. When the engine starts, the needle will move up to the upper part of the green area and stay there. If the gauge needle does not move up after the engine starts, check the condition of the battery/alternator.
11. **FUEL LEVEL GAUGE:** This gauge shows the amount of fuel that is in the fuel tank.
12. **WATER TEMPERATURE GAUGE:** This gauge shows the temperature of the coolant in the engine cooling system. The temperature of the coolant is normal when the gauge needle is in the green area of the gauge. If the gauge needle goes into the red area, stop the engine and check the level of the coolant, or check for debris on the radiator/oil cooler, or for a thermostat that does not operate correctly.

## MACHINE CONTROLS

## Direction Control Lever



1. **DIRECTION CONTROL LEVER:** This lever controls the travel direction of the machine. The center position is NEUTRAL. To travel forward, lift the lever and push completely forward. To travel in reverse, lift the lever and pull completely rearward. Make sure the direction control lever is in NEUTRAL before you start the engine or before you operate the backhoe.

**WARNING:** Uncontrolled machine movement can injure. Before you turn the operators seat around to the BACKHOE operating position, shift the direction control lever and transmission control to NEUTRAL and apply the parking brake. SA050

The direction control lever electrical circuit has an added feature which allows the operator to move the machine a short distance in the event the direction control lever receives intermittent signals that shift the transmission into neutral. By shifting the direction control lever to the opposite direction of travel that is desired, then back to the desired direction, the transmission will engage for approximately 5 seconds.

This procedure is to be used only in the event of an emergency when the unit must be moved to a safe location. Have the machine repaired immediately.

## Transmission Shift Lever and Clutch Cutout Button

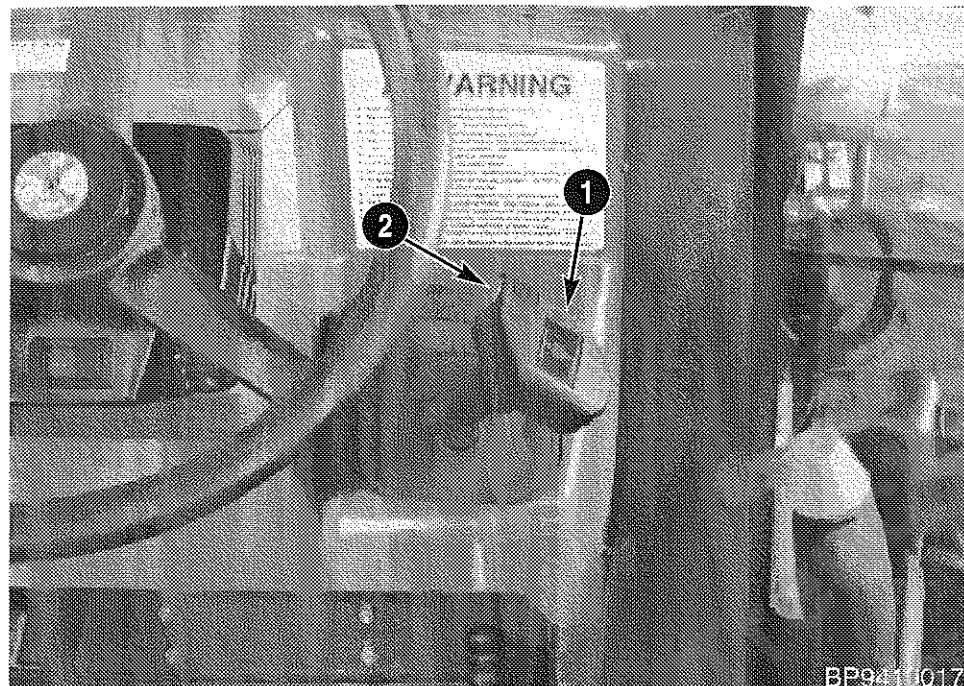

- 1. TRANSMISSION SHIFT LEVER:** The transmission has synchromesh in all four gears. You can shift to any gear without stopping the machine. Push the clutch cutout button on the transmission shift lever before you shift. Release the button to engage the clutch after the shift.

**NOTE:** When shifting to a lower gear, reduce the travel speed before you shift.

**IMPORTANT:** Always shift the transmission to *NEUTRAL* before you operate the backhoe.



**WARNING:** Uncontrolled machine movement can injure. Before you turn the operators seat around to the *BACKHOE* operating position, shift the direction control lever and transmission control to *NEUTRAL* and apply the parking brake.

SA050

- 2. CLUTCH CUTOUT BUTTON:** Push this button before you shift the transmission gears. The transmission is in *NEUTRAL* when this button is pushed.

## Foot Pedals

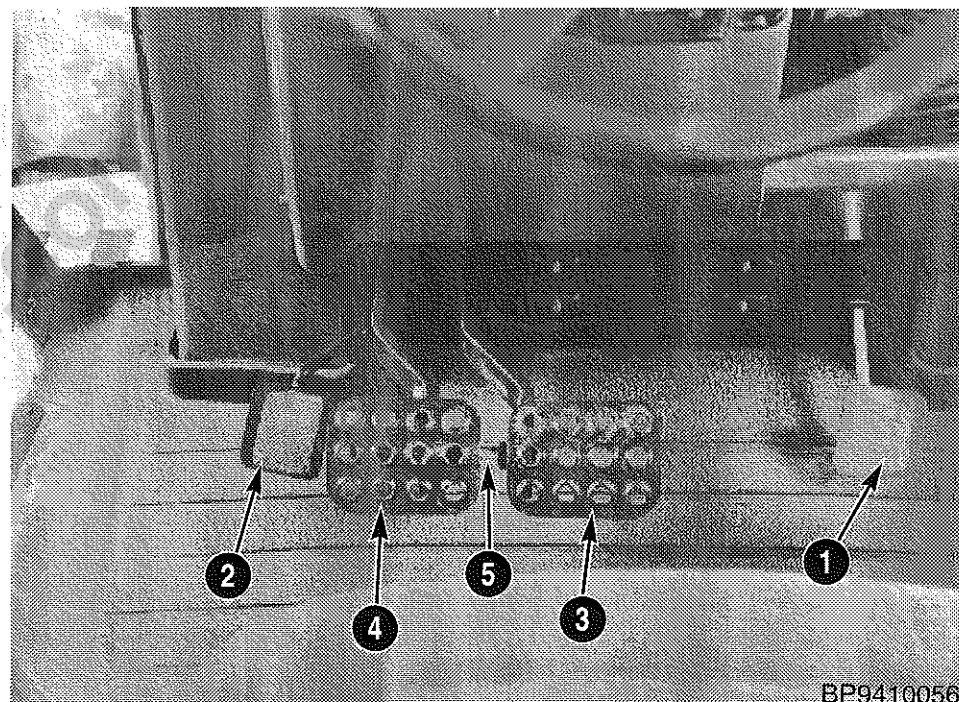

- 1. FOOT THROTTLE:** Push down on the foot throttle to increase the engine speed. Release the foot throttle to decrease the engine speed.
- 2. DIFFERENTIAL LOCK:** The differential lock gives traction to both rear wheels. See page 74 for correct operation.
- 3. RIGHT BRAKE PEDAL:** (With Brake Pedal Lock Disengaged) Push this pedal to help turn the machine to the right.
- 4. LEFT BRAKE PEDAL:** (With Brake Pedal Lock Disengaged) Push this pedal to help turn the machine to the left.
- 5. BRAKE PEDAL LOCK** - See next page.

## Brake Pedal Lock

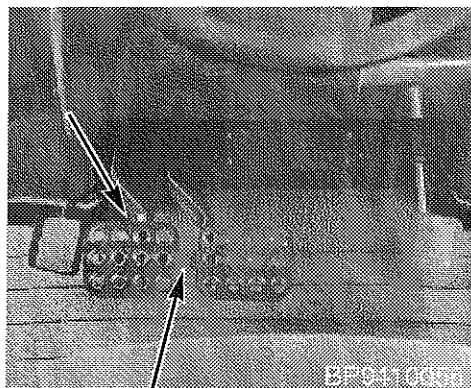

Brake Pedal Lock Engaged

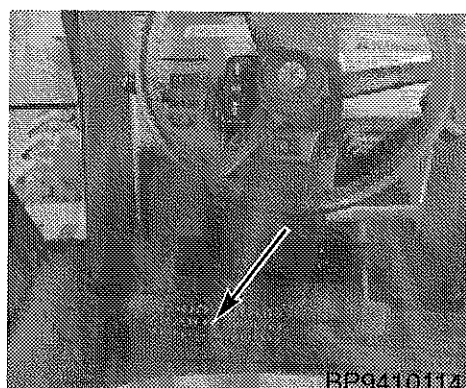

Brake Pedal Lock Disengaged



**WARNING:** Always lock the brake pedals together before you travel on roads or when you operate the machine in 3rd or 4th gear. See the instructions in this manual for brake pedals. You can cause an accident if you do not follow these procedures.

SB051

## Turn Signal and Horn Control

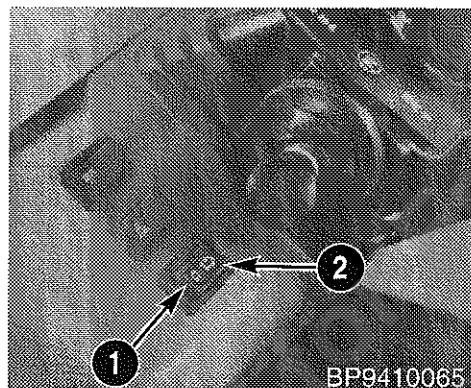

BP9410065

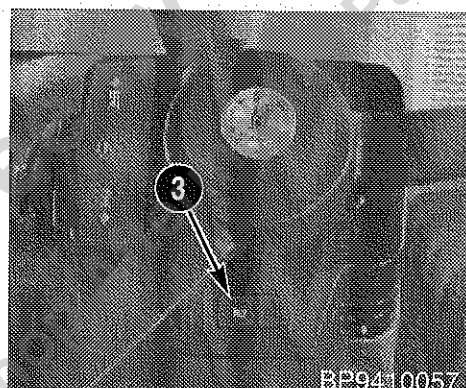

BP9410057

**TURN SIGNAL CONTROL AND INDICATORS:** Push the left side of the rocker switch emblem down to signal a left turn (1). Push the right side of the rocker switch down to signal a right turn (2). Move the rocker switch to the center to stop the signal.

**HORN:** Push the control in to sound the horn (3).

## Dome and Flasher Lamp Switches

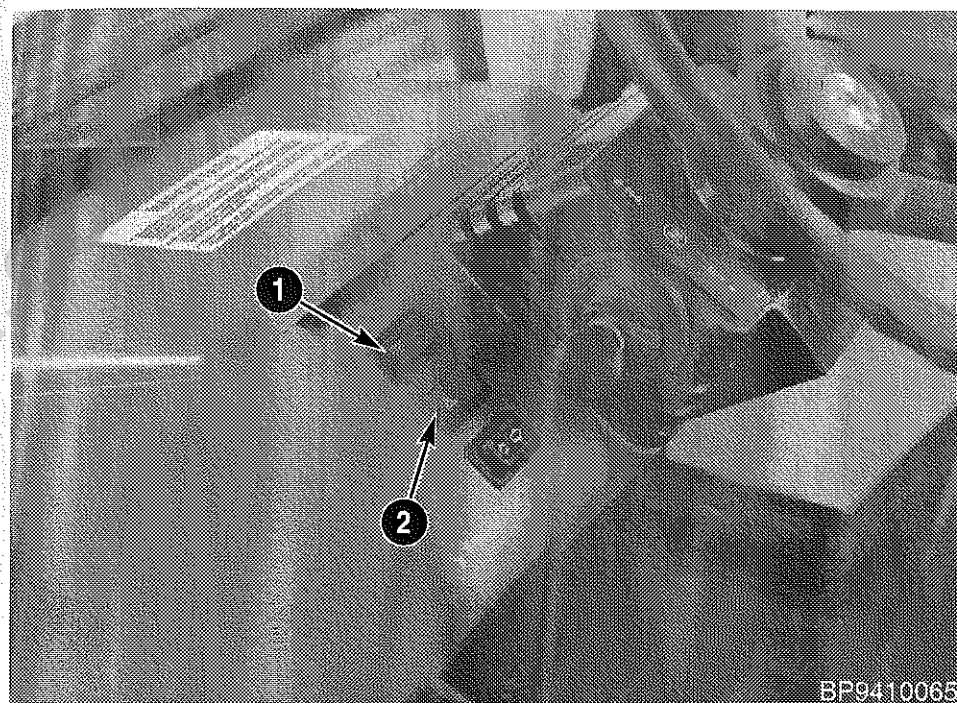

BP9410065

1. **DOMELAMP SWITCH:** Push the rocker switch emblem to illuminate the dome lamp. Push the opposite end of the rocker switch to turn the dome lamp off. The dome lamp switch can be reached from the ground.
2. **FLASHER LAMP SWITCH:** Push the rocker switch emblem to illuminate the flashers. Push the opposite end of the rocker switch to turn the flashers off.

## Driving Lamps, Front and Rear Flood Lamps, and Rotating Beacon Switches

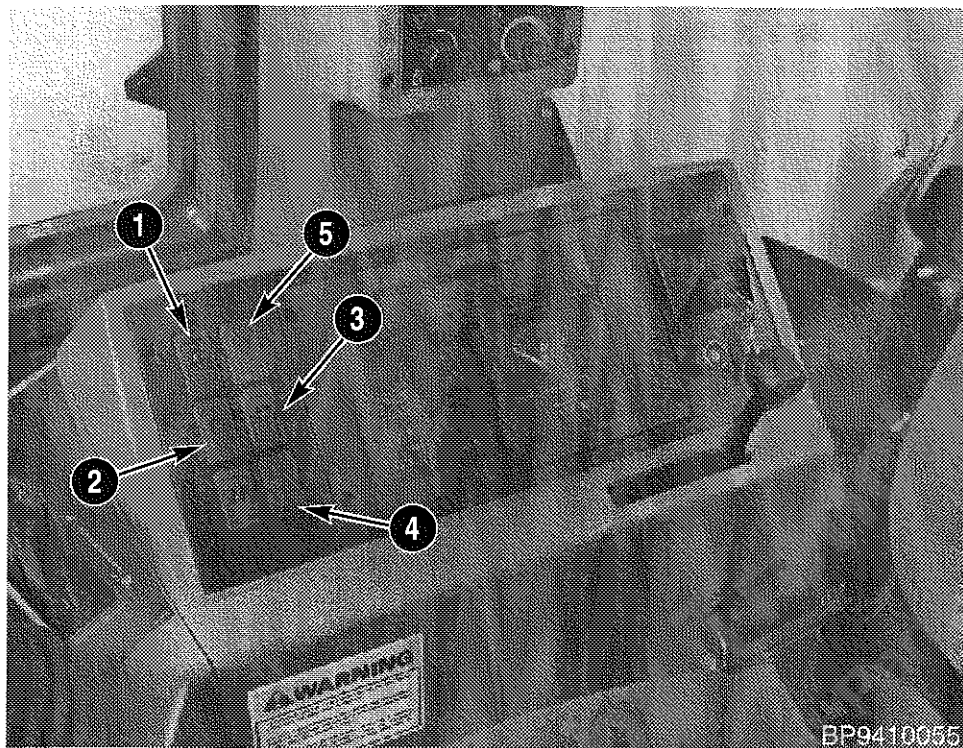

- 1. DRIVING LAMP SWITCH:** Push the rocker switch emblem to turn the driving lamps on. Push the opposite end of the rocker switch to turn the driving lamps off.
- 2. FRONT FLOOD LAMP SWITCH:** Push the rocker switch emblem to turn the front flood lamps on. Push the opposite end of the rocker switch to turn the front flood lamps off.
- 3. REAR FLOOD LAMP SWITCH:** Push the rocker switch emblem to turn the rear flood lamps on. Push the opposite end of the rocker switch to turn the rear flood lamps off.
- 4. ROTATING BEACON SWITCH (If Equipped):** Push the rocker switch emblem to turn the rotating beacon on. Push the opposite end of the rocker switch to turn the rotating beacon off.
- 5. AUXILIARY HYDRAULICS SWITCH (If Equipped):** Push the rocker switch emblem for the ON position. This will allow you to use the control lever on the backhoe console to control the backhoe auxiliary hydraulics. When operating hand held auxiliary hydraulics, putting the rocker switch in the ON position will power the attachment. Push the opposite end of the rocker switch for the OFF position.

## Alarm for Engine and Parking Brake - Not Shown

**ALARM FOR ENGINE AND PARKING BRAKE:** This alarm will sound if, (1) the engine oil pressure is low, (2) the engine coolant temperature is high, (3) the parking brake is applied and you shift the direction control lever to the FORWARD or REVERSE position.

**NOTE:** The alarm will sound if the direction control lever is in either the FORWARD or REVERSE position and the seat is turned from the driving position to the backhoe position. See page 46.

## Control Switch for Front Drive Axle - 4 Wheel Drive

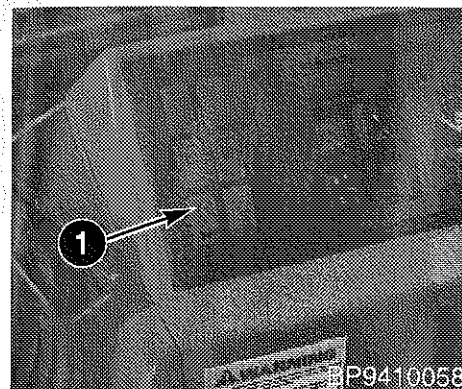

1. Front Drive Axle Engaged

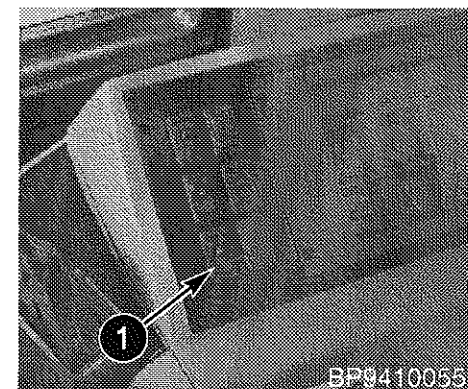

1. Front Drive Axle Disengaged

- 1. FRONT DRIVE AXLE CONTROL:** The front drive axle is engaged and disengaged by a rocker switch. To engage the front drive axle, push the rocker switch emblem. To disengage the front drive axle, push the opposite end of the rocker switch.

**IMPORTANT:** When the front drive axle is engaged, operate the machine only in first or second gear. It is recommended that you disengage the front drive axle before you operate on a hard surface or in third or fourth gear.

## Ride Control (If Equipped)

Ride Control is a feature that improves the machine ride over all types of terrain with either an empty or loaded bucket. Ride Control will reduce fore and aft pitching motion during transport and material hauling operations, while allowing increased productivity and operator comfort. It also reduces shock loads to the machine.

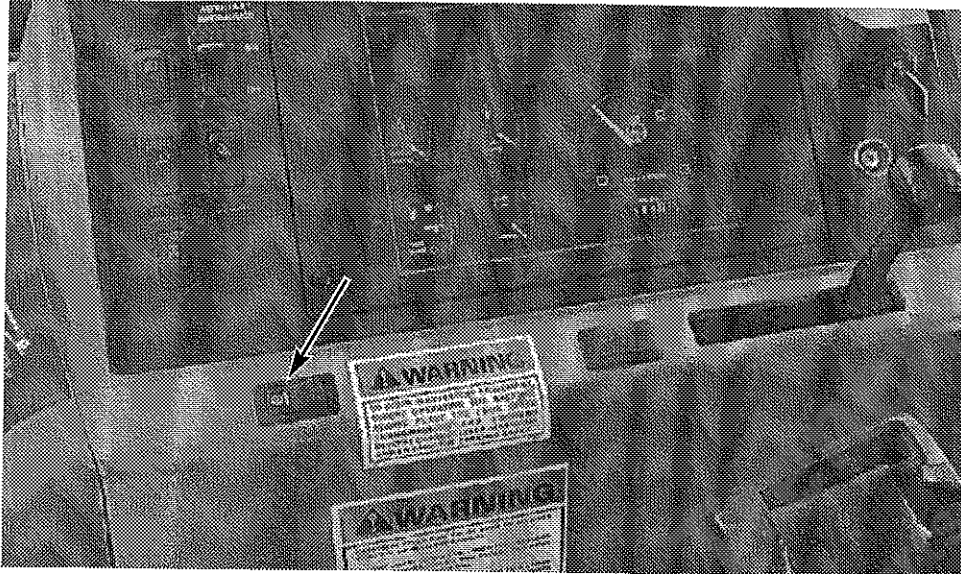

BP96G001



**WARNING:** If the ride control is turned on, with the key switch in the ON or ACC. position, the loader arms can drop or rise slightly, due to the hydraulic accumulator.

M511



## WARNING

DO NOT TURN THE RIDE CONTROL ON, IF THE LOADER ARMS AND BUCKET ARE HOLDING THE FRONT OF THE MACHINE OFF THE GROUND. THE MACHINE CAN DROP CAUSING SERIOUS INJURY OR DEATH.

255927A1

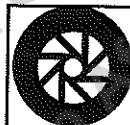

BT96H016

To engage, lower the loader bucket to or near the ground line. Push the Ride Control Switch to the on position (emblem down).

The green switch lamp will illuminate. There can be a slight loader arm drop or rise when the ride control is activated.

To disengage, push the Ride Control Switch to the off position (emblem up). The green switch lamp will go out.

When the ride control is activated the loader down pressure is limited to the weight of the loader and the attachment (bucket). The weight of the loader attachment (bucket) is hydraulically cushioned during transport which is a normal condition of the ride control.

Ride control can not be used for fine grading with the loader bucket, during backhoe operation, or when precise placement of the loader is required.

To test the ride control refer to the Service manual.

## Seat Switch/Buzzer System

This buzzer will sound when the operator rotates the seat from the driving position to the backhoe position and leaves the direction control lever in gear.

A warning decal on the machine, repeated in this operators manual with additional operating instructions, requires the operator to take certain precautions before operating the backhoe. The seat switch buzzer is an additional warning. The buzzer will sound if the seat is rotated approximately 15 to 20 degrees from the straight forward position.

To make sure the system is working, the operator must know that the same buzzer will also sound if the parking brake is set and the direction control lever is in forward or reverse. The same buzzer is also used for low oil pressure and high engine temperature.

## Seat Switch/Buzzer System - Check Procedure

1. The operator must be in the seat in the driving position with the seat belt on.
2. Start the engine.
3. Park the machine on a level surface in a clean area. Make sure all other persons are clear of the area.
4. Make sure the parking brake OFF, and the transmission shift lever is in NEUTRAL with the loader bucket on the ground.
5. Put your foot on the service brake and leave it there.
6. Move the direction control lever to the FORWARD position and turn the seat approximately 15 to 20 degrees. The buzzer will sound. The same procedure is repeated for REVERSE. The buzzer and also the backup alarm will sound. This will tell if the seat switch buzzer system is operating.

Another suggestion is to lower the stabilizers and lift the rear wheels off the ground. If the machine has four wheel drive, the front wheels also need to be off the ground to make sure the machine does not move.

## Hand Throttle, Key Switch, and Ether Starting Aid Button

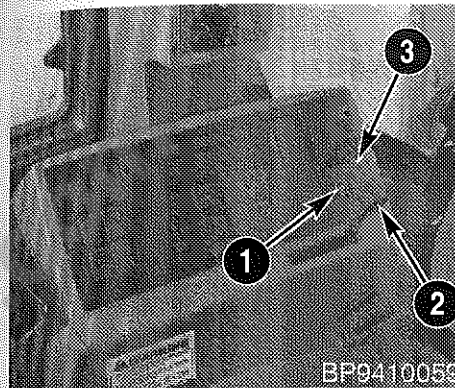

1. **ETHER STARTING AID BUTTON (If Equipped):** See Ether Cold Start Aid on page 70 for the correct procedure to use the cold starting aid button.
2. **HAND THROTTLE:** Push the hand throttle toward the front of the machine to increase the engine speed. Pull the hand throttle rearward to decrease the engine speed.

3. **KEY SWITCH:** The key switch has four positions:

**ACC** - Turn the key counterclockwise to ACC to give power to the accessories.

**ON** - Turn the key clockwise to the ON position. Before you start the engine, check the condition of the warning lamps for engine oil pressure and alternator. Use the voltmeter to check the condition of the battery(ies).

**START** - Turn the key completely clockwise to the START position to actuate the starter motor. After the engine starts release the key. The key will return automatically to the ON position.

**NOTE:** When in the START position, you can also check the condition of the warning lamps for the air filter and hydraulic filter.

**OFF** - To stop the engine, turn the key to the OFF position. After the engine has stopped, remove the key.



**WARNING:** When you operate the backhoe, use the hand throttle to control the engine speed. You can have an accident if you use the hand throttle for any other operation.

SB052

## Parking Brake

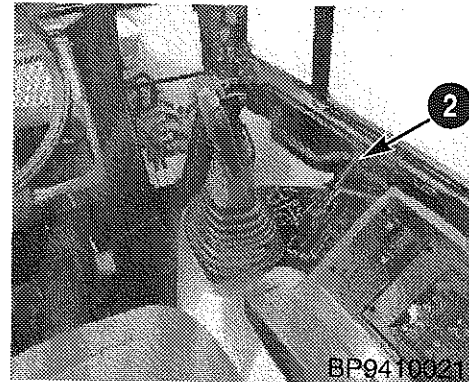
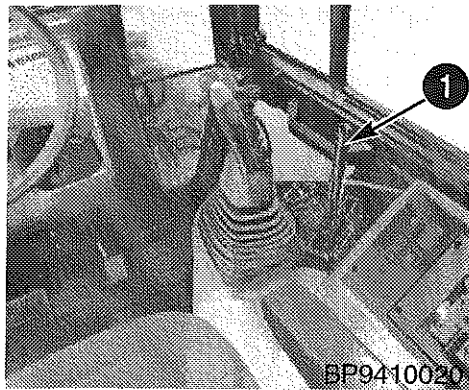

1. Pull the parking brake control lever back to apply the parking brake.
2. Push the parking brake control lever forward to release the parking brake.

**NOTE:** A warning buzzer will sound if you shift the direction control lever into FORWARD or REVERSE while the parking brake is engaged.

**PARKING BRAKE ADJUSTMENT:** Release the parking brake and turn the end of the lever clockwise two or three turns. Pull the parking brake lever back. See the topic "Parking Brake Check" on page 65 and test the parking brake. If the parking brake does not hold the machine, see the service manual or your dealer.



**WARNING:** Uncontrolled machine movement can injure. Before you turn the operators seat around to the BACKHOE operating position, shift the direction control lever and transmission control to NEUTRAL and apply the parking brake.

SB050

**IMPORTANT:** You can damage the parking brake, which is also the service brake, if you move the machine and the parking brake is applied.

## LOADER CONTROLS

### Lift Arm and Bucket Control

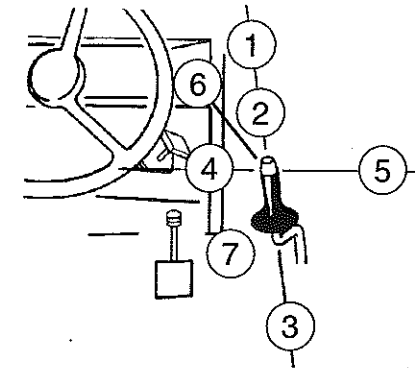

B9410135

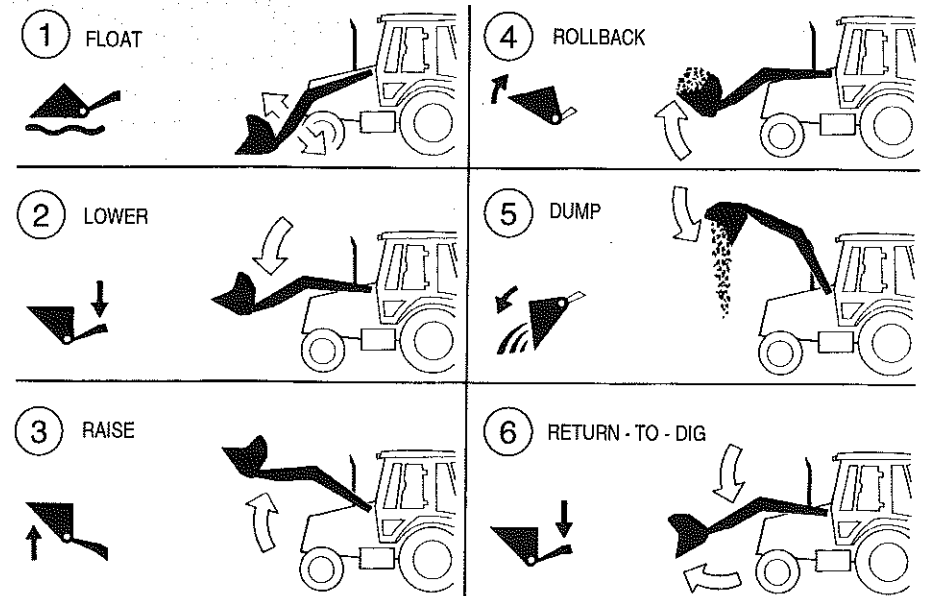

B9410261

① FLOAT: When in FLOAT, the bucket can follow the level of the ground without movement of the control lever.

⑥ RETURN-To-Dig: After the bucket is dumped, move the control to ROLLBACK and FLOAT. When the bucket is at the height selected, pull the control back to HOLD.

⑦ HOLD - NEUTRAL: The loader lift arms and bucket stop moving when the control lever is in HOLD. When released, this control will return to HOLD automatically. You must manually move this control from FLOAT to HOLD.

**Clam Control (If Equipped) Clutch Cutout Button**

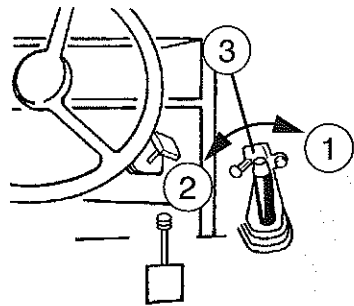

B9410133

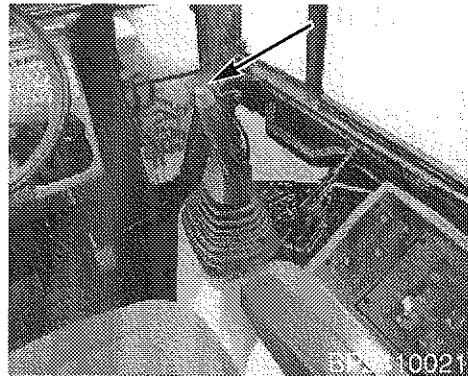

B9410021

① CLAM OPEN



② CLAM CLOSED



B9410262

③ HOLD - NEUTRAL: The clam stops moving when the control handle is in HOLD. The clam control handle is equipped with a lock latch. The latch should be in the locked position when the clam is not in use.

**NOTE:** The latch is not automatic - it must be manually engaged.

Push the clutch cutout button to allow the engine to increase speed and supply the loader with more hydraulic oil for greater loader power and faster control function. When you push the clutch cutout button, the transmission is disengaged from the drive wheels. Release the clutch cutout button to engage the transmission power. The machine can move freely when the clutch cutout button is pushed. If required, use the brake to stop the machine.

**BACKHOE CONTROLS WITH FOOT SWING**

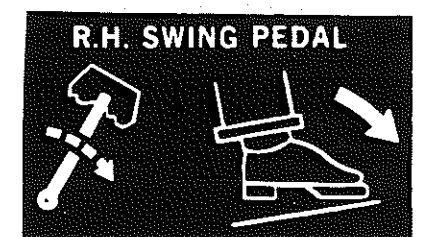
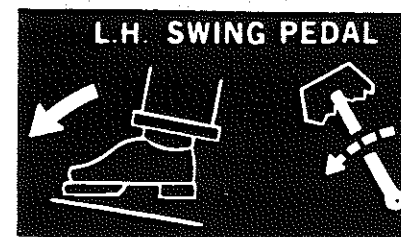
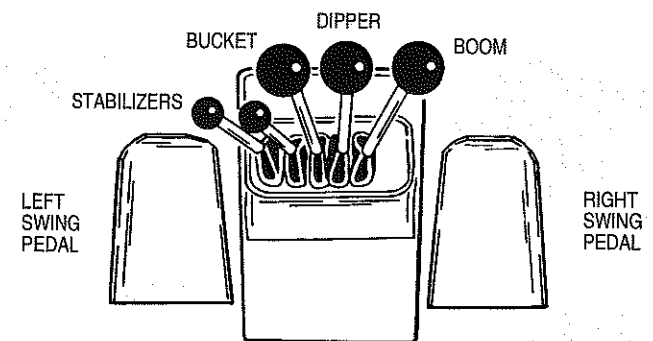
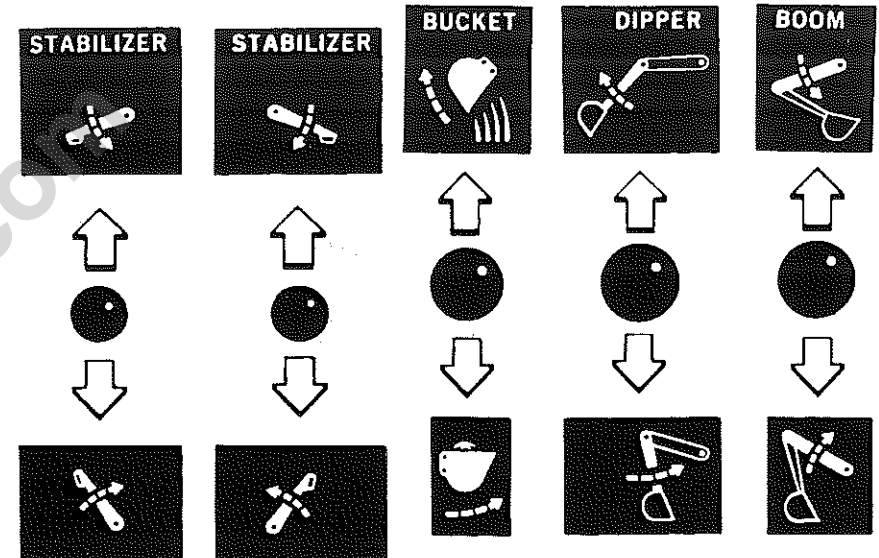

### BACKHOE CONTROLS WITH HAND SWING

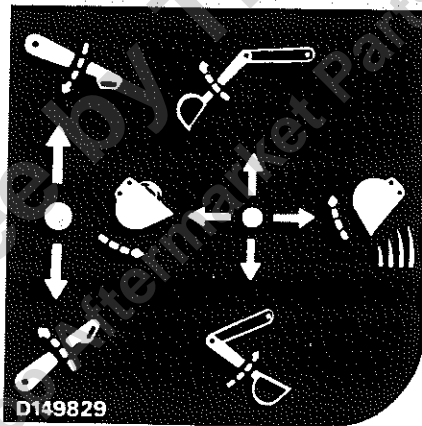
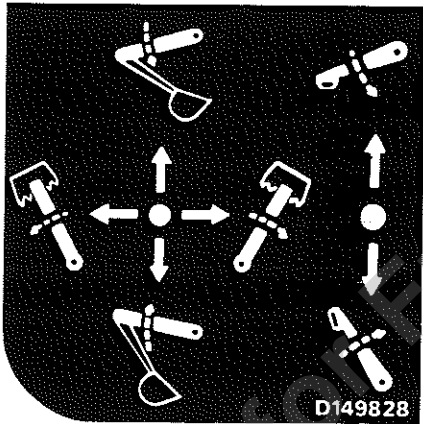
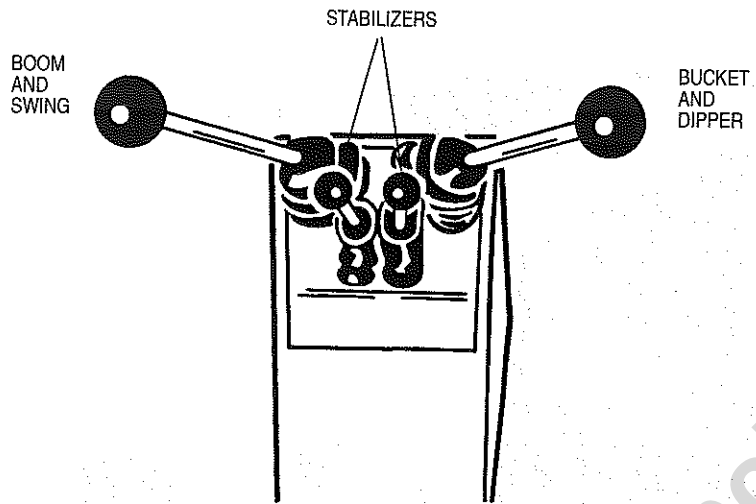

B902393J

### EXTENDAHOE CONTROL WITH FOOT SWING

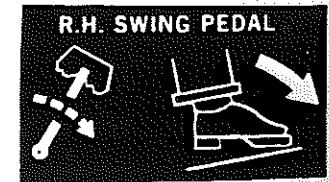
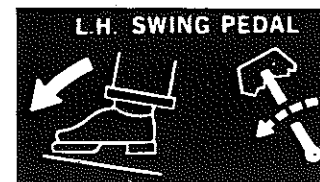
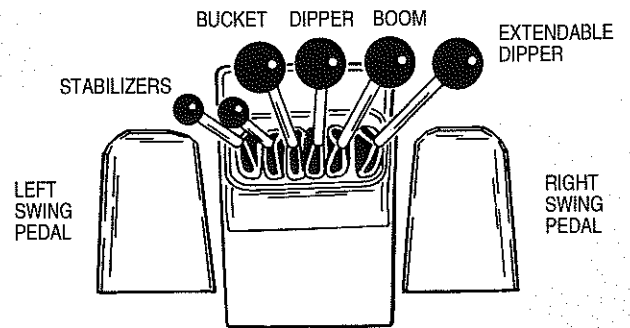
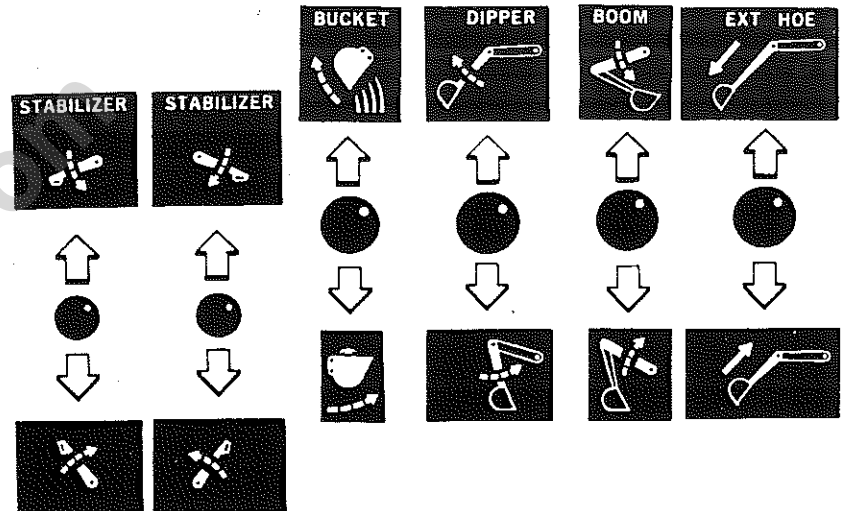

B902394J

### EXTENDABLE HOE CONTROLS WITH HAND SWING

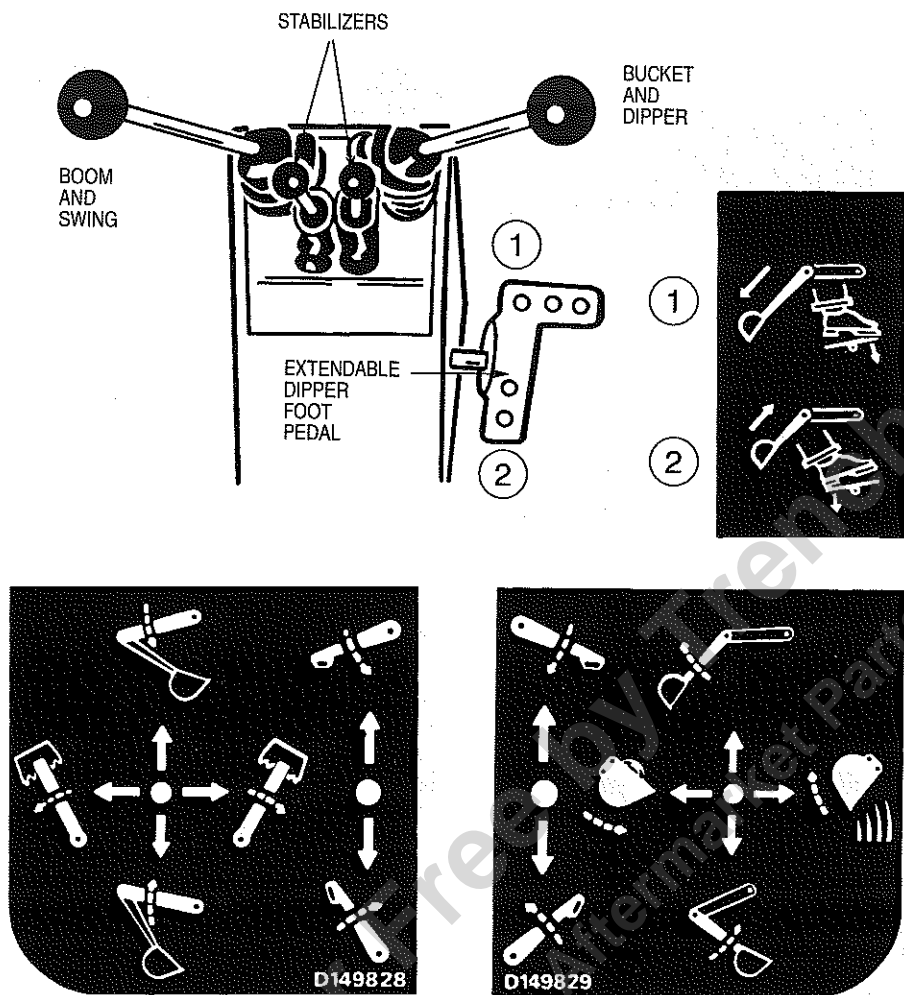

B902395J

### AUXILIARY ATTACHMENT CONTROL FOR BACKHOES

This option allows the operator to install hydraulically actuated attachments on the dipper when the bucket is removed. Actuate the attachment by moving the control lever shown below. Follow the instructions given by the manufacturer of the attachment.

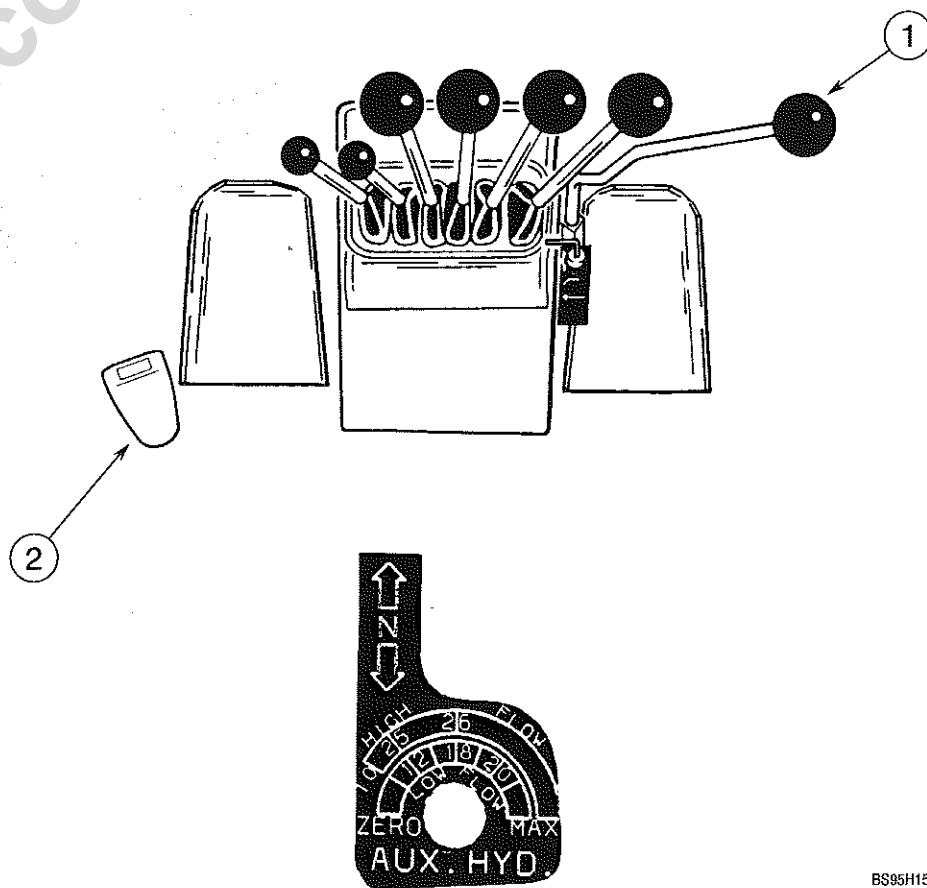

- 1. Auxiliary Attachment Control Lever
- 2. Attachment Pedal

BS95H153

## STANDARD SEAT



**WARNING:** An accident or sudden machine movement can cause injury or death. Always fasten the seat belt and adjust the seat before you start the engine.

SB053

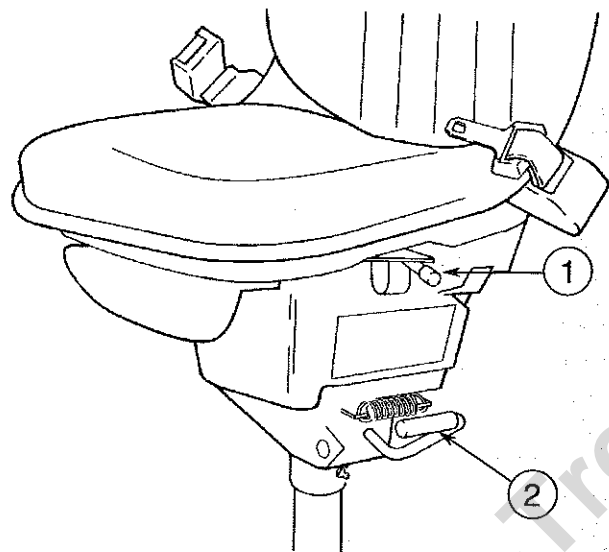

B9410144S

1. Forward/Rearward and Seat Turn Around Control
2. Height Control

The operators seat can be moved up and down, forward and rearward, and can be turned around to operate the backhoe or the loader.

1. **FORWARD/REARWARD AND TURN AROUND CONTROL:** Push the control lever rearward and move the seat forward or rearward. Release the control lever and make sure the seat is locked in position. To turn the seat, push the control lever rearward and turn the seat. The seat can be rotated from any forward or rearward position. Adjust the seat as required. Release the control and make sure the seat is locked in position.
2. **HEIGHT CONTROL:** Pull the height control lever up and adjust the height of the seat. Release the control lever and make sure the seat is locked in position.

## SUSPENSION SEAT

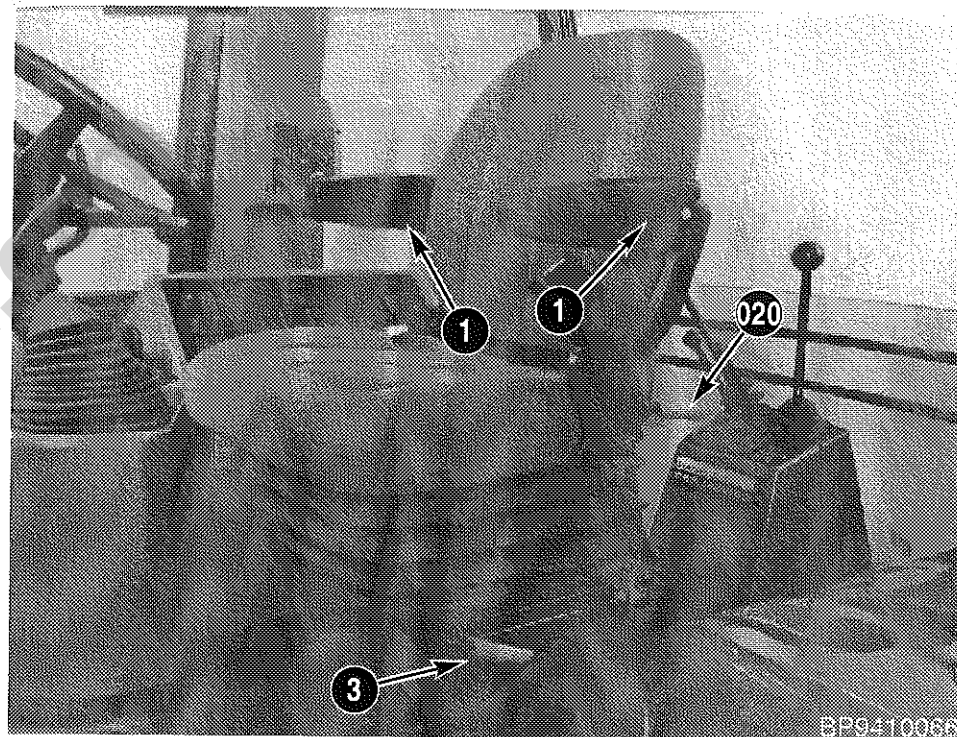

BP9410066

The suspension seat can be raised or lowered, moved forward or rearward, and turned to operate the backhoe or loader. The arm rests can also be adjusted for operator comfort. The seat can be adjusted for your weight.

1. **ARM REST CONTROLS:** Raise the arm rest and adjust the seat screw that controls the height.
2. **SEAT HEIGHT CONTROL:** Pull the height control lever up and adjust the height of the seat. Release the control lever and make sure the seat is locked in position.
3. **FORWARD/REARWARD CONTROL AND SEAT TURN AROUND:** Pull the control lever up and move the seat forward or rearward. To turn the seat, pull the control lever up and turn the seat. The seat can be rotated when in any forward or rearward position. Adjust the seat as required and release the control.

**OPERATORS WEIGHT ADJUSTMENT:**

The operators seat is adjustable for persons weighing between 50 to 136 kg (110 and 300 lbs). Turn the weight control knob until the weight indicator is positioned at your approximate weight. Sit in the seat and move up and down a few times. Make minor adjustments to the weight control knob as required.

**NOTE:** Lubricate the suspension seat with a small amount of grease. See page 132.

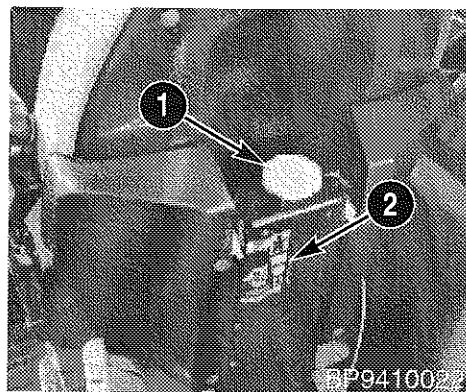

1. Operators Weight Control
2. Weight Indicator

**SEAT BELTS****50 mm (Two Inch) and 76 mm (Three Inch) Wide Belts**

Due to local regulations, 76 mm (three inch) belts are on some machines.

**NOTE:** The illustrations that follow show the correct procedure to fasten and release the belt.

1. Fasten the belt end into the left-hand buckle.

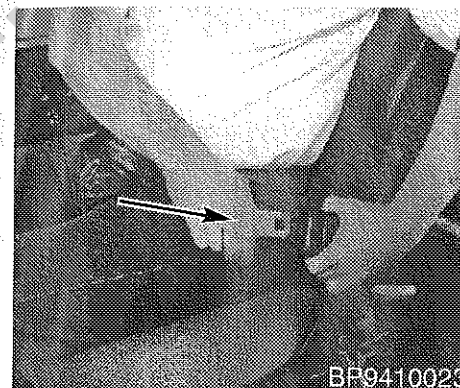

2. To release the seat belt, push the button on the buckle.

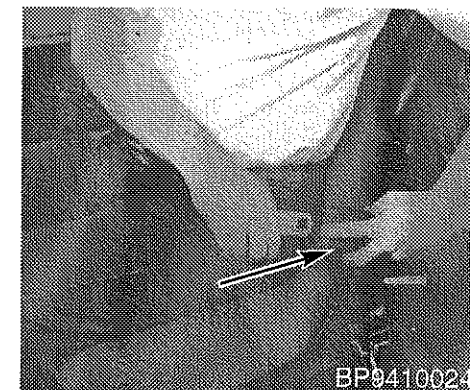

**IMPORTANT:** Make sure the belt end and buckle are securely fastened.



**WARNING:** You are protected by the ROPS system on this machine (Roll-Over Protective Structure). The seat belt is an important part of the ROPS system. Before you operate this machine, always fasten the seat belt. If the machine rolls over and you **DO NOT** have the seat belt fastened, you can be crushed by the ROPS or the machine. SA080

For seat belt maintenance see page 169.

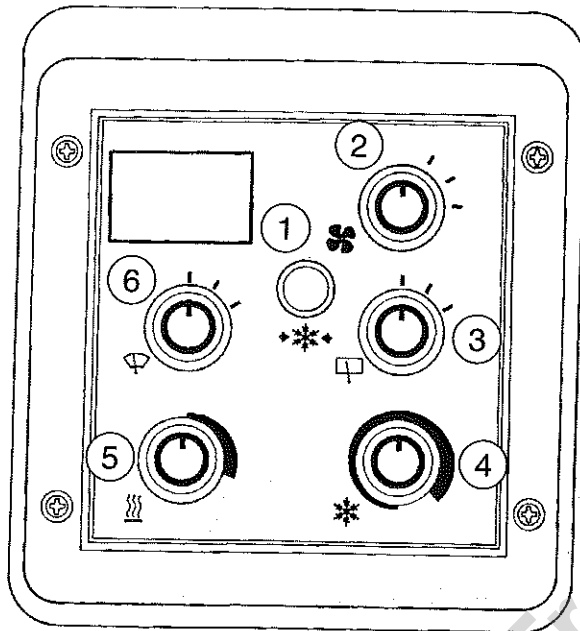
**CAB CONTROLS (If Equipped)**

B9410136

- 1. AIR CONDITIONING WARNING LAMP (If Equipped):** This warning lamp illuminates when the air conditioning has stopped due to refrigerant pressures that are too high or too low. The lamp will also illuminate when the system needs service or the outside air temperature is too cool for the system to work.

To start the air conditioner again, turn the air conditioning temperature control to OFF and back to ON again.

If the warning lamp stays ON, see your Service Manual.

- 2. BLOWER SWITCH:** The blower switch has four positions (1) OFF, (2) LOW, (3) MEDIUM and (4) HIGH. Turn the switch clockwise to increase the air flow in the cab. Turn the switch counterclockwise to the OFF position to stop the flow of air.
- 3. REAR WIPER SWITCH:** The rear wiper switch has three positions, (1) OFF, (2) LOW, and (3) HIGH. Turn the switch clockwise to increase the wiper speed and turn the switch counterclockwise to stop the wiper. Make sure the wiper is completely to the side before you open the window.

**NOTE:** The rear wiper will operate only when the rear window is completely closed.

- 4. TEMPERATURE CONTROL FOR THE AIR CONDITIONER (If Equipped):** Turn the temperature control clockwise to decrease the temperature of the cab. Turn the control completely clockwise for the coldest setting. Turn the control completely counterclockwise for the OFF position.
- 5. HEATER CONTROL (If Equipped):** Turn the heater control clockwise to increase the temperature in the cab. Turn the heater control counterclockwise to decrease the heat.
- 6. FRONT WIPER SWITCH:** The front wiper switch has three positions, (1) OFF, (2) LOW and (3) HIGH. Turn the switch clockwise to increase the wiper speed and turn the switch counterclockwise to stop the wiper.

**HEAT SHUTOFF VALVE (See Below):** Be sure the engine is shut off and cool when making the following adjustments. During warm weather, turn the heater shutoff valve clockwise to stop the flow of hot coolant to the heater. Turn the heater shutoff valve counterclockwise when cold weather begins.

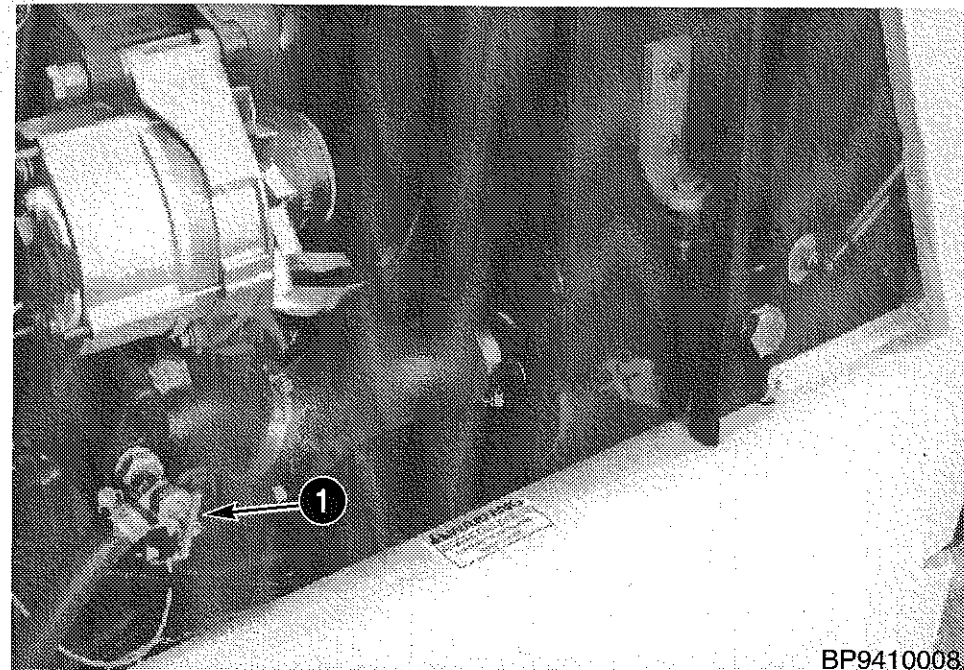

BP9410008

1. Heater Shutoff Valve

## Air Louvers (If Equipped)

The air louvers in this cab are adjustable and can be completely closed. Move the two bars in each louver to the center to stop air flow. Move each bar outward to start air flow.

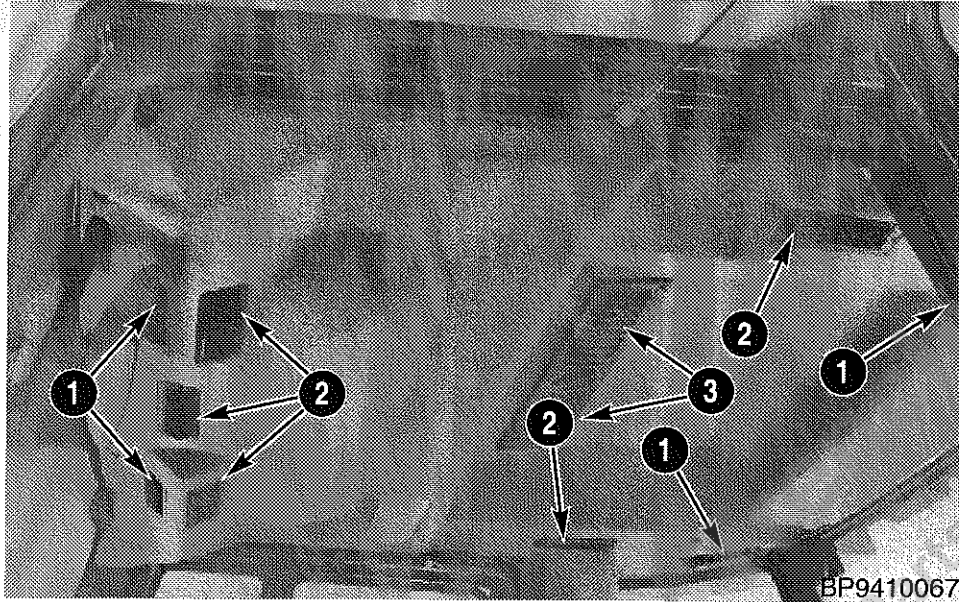

- DEFROST LOUVERS:** There are two louvers in the front of the cab and two in the rear of the cab. To get maximum air flow, close the three main louvers in the center front of the cab and the two louvers by the centerposts.
- MAIN LOUVERS:** Three louvers in the center front of the cab and the two louvers by the centerposts are used to direct the flow of air for heating and cooling.
- RECIRCULATION LOUVERS:** The louver behind the main louvers is used for recirculation of the cab air. To get maximum pressure in the cab, close the recirculation louvers. To get maximum heat in the winter and maximum cooling in the summer, open the recirculation louvers. To avoid sucking dirt into the core of the heater and/or air conditioner and damaging the system, close the recirculation louvers while running the machine with the doors and/or rear window open.

**NOTE:** During some conditions, it is possible to have ice on the air conditioning core. Ice can be caused by operating at **LOW** blower speed and **MAXIMUM** cold setting of the temperature control. It is best to operate the **MEDIUM** or **HIGH** speed setting of the blower and center range of the temperature control. If ice does block the core, you will feel a reduction of air flow in the cab. Close the recirculation louver, turn the temperature control to **OFF** and run the blower at **HIGH** speed. Another cause of ice can be a restricted air filter in the cab.

## Door Latch

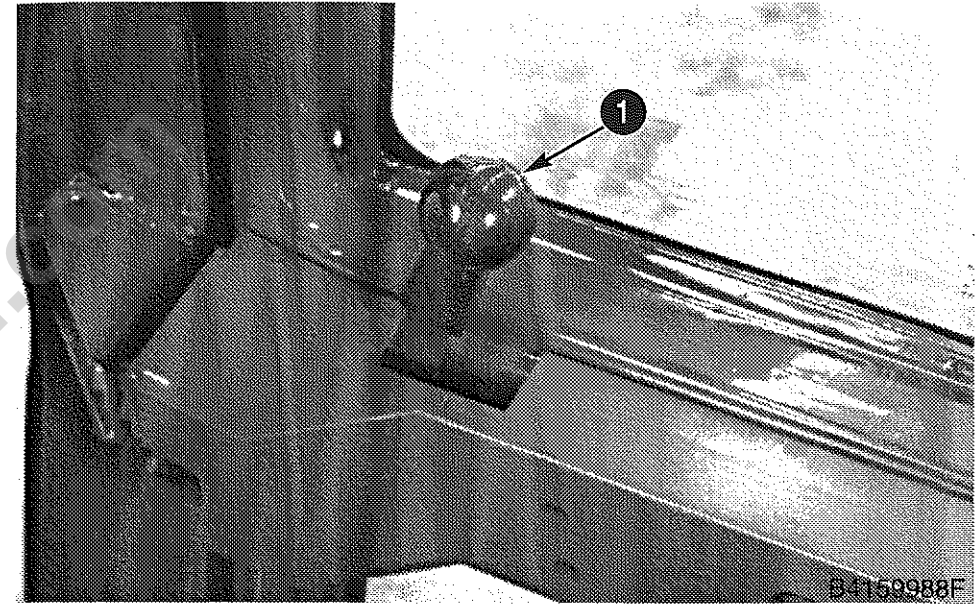

1. Pull Back To Open Door

## Window Latch

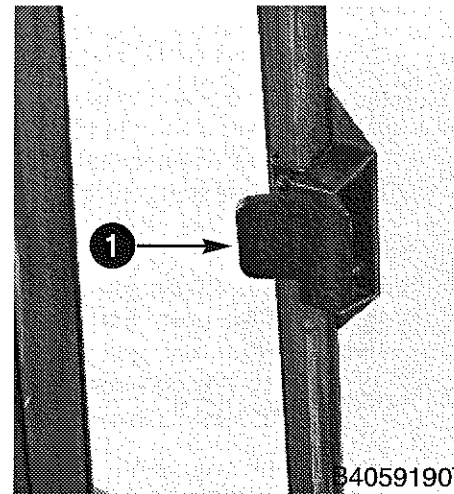

1. Tab

Push the tab to release and open window.

## Window Retainer

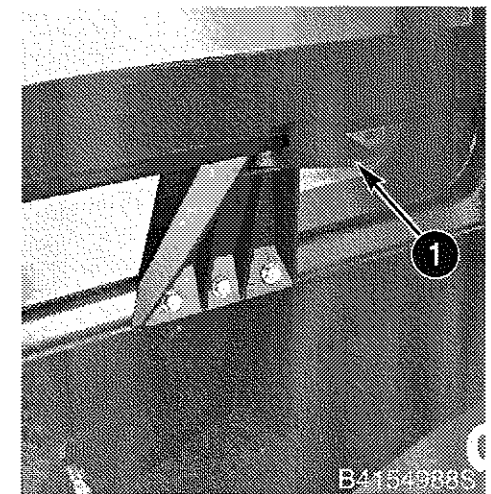

1. Window Retainer

Push the window completely back to hold the window in the **OPEN** position. Push the window retainer down to release.

## Rear Windows



All Windows Full Down

To raise a window, use both handles and raise the window. To lower a window raise the window with both handles, pull the latch bars to the rear, and lower the window. Do not raise or lower the windows using the latch bars.

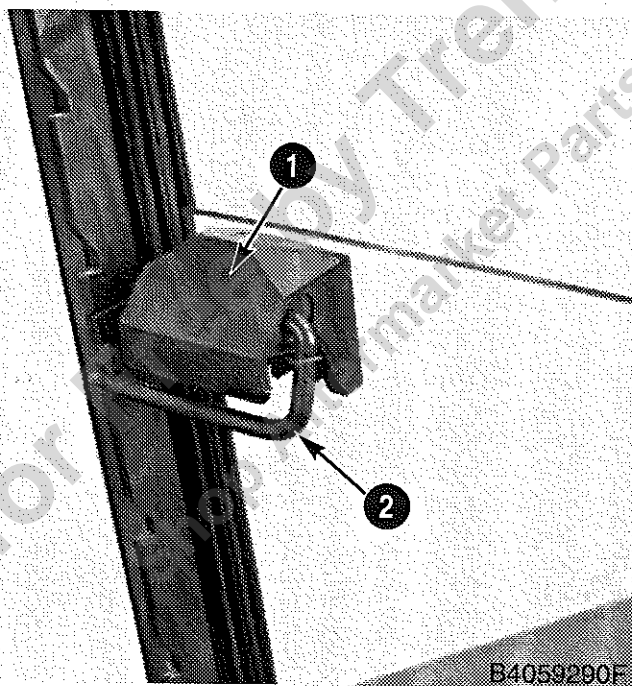

1. Handle

2. Latch Bar

The rear windows in the cab have four positions:

1. All closed - top window up and bottom window 1/2 up.
2. Top window up and bottom window full down.
3. Top window 1/2 down and bottom window full down.
4. Both windows full down.

## OPERATING INSTRUCTIONS

### RUN-IN PERIOD OF A NEW MACHINE

#### Wheel Nuts and Bolts

When the machine is new or when a wheel is removed for service, check the wheel nuts or bolts every 10 hours of operation until the wheel nuts or bolts remain tight. See page 112 for the correct torque.

**NOTE:** This procedure is for front wheels only. For rear wheel nut torquing procedure see page 112

#### After Delivery Check

Have your dealer do the After Delivery Check after the first 20 hours of operation. See pages 255 and 257.

#### In-Line Fuel Filter

Replace the in-line fuel filter after the first 100 hours of operation.

#### Foot Brake Check

Check the operation of the foot brakes on a hard level surface after the first 100 hours of operation. Make sure the area is clear of other persons. Lock both pedals together with the brake pedal lock and shift the transmission to second gear. Drive the machine forward at full throttle. When the machine is moving at full speed, stop the machine. The machine must stop smoothly in a straight line and the brake pedal effort must feel firm.

**IMPORTANT:** See the service manual for this machine or see your dealer if the machine does not stop in a straight line or if the brake pedal effort feels soft.

#### Parking Brake Check

Check the operation of the parking brake after the first 100 hours of operation. Make sure the area is clear of other persons. Apply the parking brake and shift the transmission to third gear. Shift the transmission direction control to FORWARD and increase the engine speed to 1500 rpm. The machine must not move.

**IMPORTANT:** If the machine moves, adjust the parking brake. See page 48.

#### Engine Operation

During the first 20 hours of operation, or if you rebuild the engine, make sure you do the following:

1. Operate the machine with normal loads for the first 8 hours. Do not work the engine hard at stall speeds (wheels slowly turning or stopped and the engine running at full throttle).
2. Keep the engine at normal operating temperature.
3. Do not run the engine at idle speeds for long periods of time.

## ENGINE OPERATION



**WARNING:** Before starting engine, study operators manual safety messages. Read all safety signs on machine. Clear the area of other persons. Learn and practice safe use of controls before operation. It is your responsibility to understand and follow manufacturers instructions on machine operation, service, and to observe pertinent laws and regulation. Operators and service manuals can be obtained from your dealer.

SB055

### Walk-Around Inspection

Do the following each day before you start the engine.

1. Check for leaks under the machine.
2. Check the tires for damage.
3. Check the machine for broken, missing, or loose parts.
4. Clean any debris from the machine. Make sure the radiator area is clean.
5. Clean or replace any safety or instructional decals that cannot be read. See page 21 for instructions to clean or replace decals.
6. Clean the steps, hand rails, and operators compartment.
7. Check the engine oil level.

**NOTE:** If this is a new machine, or a machine with a rebuilt engine, see Run-In Period on page 65 for additional information.

### Starting the Engine

**NOTE:** If the machine has not been run for several weeks, or if the engine oil filter has been replaced, prime the turbocharger lines with oil. See page 67 for the instructions to fill the turbocharger lines with oil.

1. Make sure the seat is in the LOADER position.
2. Adjust the seat and fasten the seat belt.
3. Make sure the parking brake is applied, the direction control lever is in NEUTRAL and the engine hand throttle is pushed back to the IDLE position.
4. Turn the key switch to ON and check the engine oil pressure and alternator warning lamps. Both lamps must illuminate.

**NOTE:** If the weather is cold, see pages 69 through 72 for methods to help start the engine.

5. Push the foot throttle 1/4 down and turn the key switch to the START position to actuate the starter motor. Before the engine starts, check the air cleaner and hydraulic fluid filter warning lamps. Both lamps must illuminate.

6. If the engine starts and stops, do not actuate the starter motor again until the starter motor stops turning.

**NOTE:** Do not operate the starter motor more than 30 seconds at one time. Let the starter motor cool for two minutes before you actuate the starter motor again. While the starter motor is engaged, white or black smoke must be seen at the exhaust pipe. If no smoke is seen, check the fuel supply.

7. After the engine starts, check the instruments to make sure the gauge indications are correct. Run the engine at 1000 rpm until the coolant temperature is warm.

### Starting Procedure - Engine with Turbocharger

If the machine has not been run for several weeks, or if the engine oil filter has been replaced, prime the turbocharger lines with oil.

1. See the following photo and disconnect the wire to the injection pump solenoid. This will prevent the engine from starting.

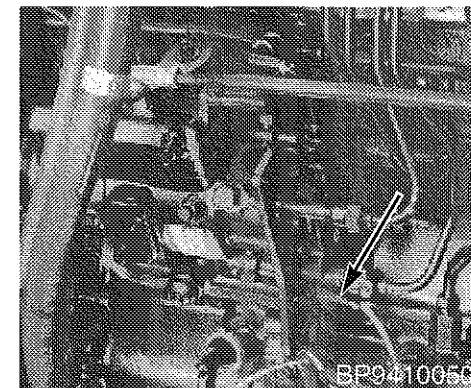

2. Turn the key switch to START and actuate the starter for 10 seconds.
3. Connect the wire to the injection pump solenoid and start the engine. Follow the procedure on page 66.
4. Run the engine at idle speed for one or two minutes before moving the machine.

### Engine Speed

Do not run the engine at idle speed for long periods. This can cause a low operating temperature. Low operating temperature can cause acids and deposits in the engine oil. It is recommended that you run the engine at full throttle when operating conditions permit and when safe.



**WARNING:** Jumping on or off the machine can cause an injury. Always face the machine, use the hand rails and steps, and get on or off the machine slowly.

SA038

## Parking the Machine and Stopping the Engine

1. Before you leave the machine, make sure the machine is parked on a level surface. The machine must be on level ground before you do scheduled maintenance.

**IMPORTANT:** If you must temporarily park the machine on a hillside, put the front of the machine toward the bottom of the hill. Make sure the machine is behind an object that will not move.

2. Lower the loader bucket to the ground.
3. Apply the parking brake and shift the direction control lever to NEUTRAL.



**WARNING:** Jumping on or off the machine can cause an injury. Always face the machine, use the hand rails and steps, and get on or off the machine slowly.

SA0038

4. Run the engine at idle speed for two minutes or more if the engine has been working at full load. This procedure will cool the engine parts evenly.

**NOTE:** Turning the engine OFF at higher than idle RPM will damage the turbocharger.

5. Move the backhoe into the transport position or lower the backhoe bucket to the ground. Move the hand throttle to the IDLE position and stop the engine. See page 100 for backhoe transport.

6. Turn the key switch to OFF to stop the engine. Remove the key.

## ENGINE STARTING AIDS



**WARNING:** Starting fluid (ether) can cause injury or death. An explosion can result if sparks, flame, or extreme heat contact the ether in the starting fluid container. Do not breathe starting fluid vapors. Wear face protection when you remove or install a starting fluid container or when you use an aerosol spray starting fluid. Use starting fluid according to instructions in this manual.

SA039

### Case Starting Fluid - Hand Held Can

1. Make sure the parking brake is engaged and the direction control lever is in NEUTRAL.
2. Get another person to help you start the engine.
3. Push the foot throttle completely down.

4. Turn the engine key switch to START. Have the second person inject the ether spray into the air intake.

**NOTE:** Do not operate the starter motor for more than 30 seconds at one time. Wait two minutes so the starter motor can cool.

5. When the engine starts, run at 1000 rpm until the coolant temperature is warm.

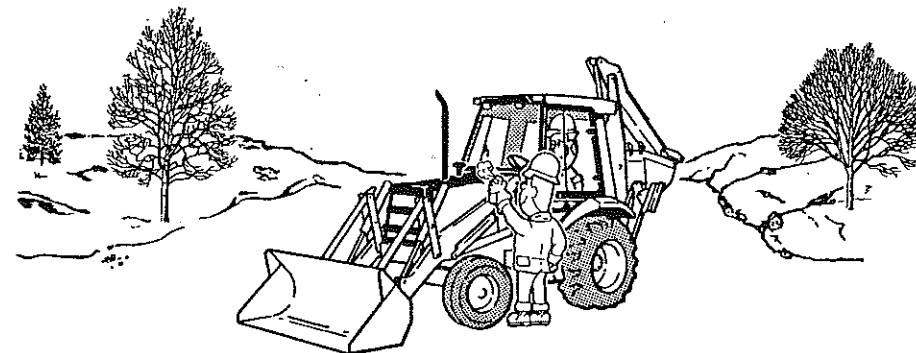

B861775R

## Ether Cold Start Aid



**WARNING:** Starting fluid (ether) can cause injury or death. An explosion can result if sparks, flame, or extreme heat contact the ether in the starting fluid container. Do not breathe starting fluid vapors. Wear face protection when you remove or install a starting fluid container or when you use an aerosol spray starting fluid. Use starting fluid according to instructions in this manual. SA039

### Important Rules When Using Ether

1. Know the correct method for starting the engine with ether.
2. If you weld, grind, or use a cutting torch on the machine, always remove the starting fluid container from the machine. Use compressed air to remove any ether fumes from the area.
3. Do not breathe the ether vapor or let the ether touch your skin.
4. Keep the starting fluid container out of the reach of children.
5. When the temperature is above 1.6° to 4.4°C (35° to 40°F) remove the starting fluid container from the machine. See page 164.
6. Before you discard an empty container, use rubber gloves and push the valve in the end of the container to remove any pressure. Do not make a hole in the container and do not put the container in a fire.
7. Do not store extra containers in the operators cab.
8. Always read the instructions on the ether container.

### Starting the Engine with Ether

The Ether Start Aid injects a measured amount of ether into the engine during cold weather starting.

1. See page 66 and use the correct procedure to start the engine.
2. Push the foot throttle 1/2 open and hold until the engine starts.
3. Actuate the starter motor.
4. Push and release the ether starting aid button. If the engine does not start after two attempts, check the supply of ether in the container.

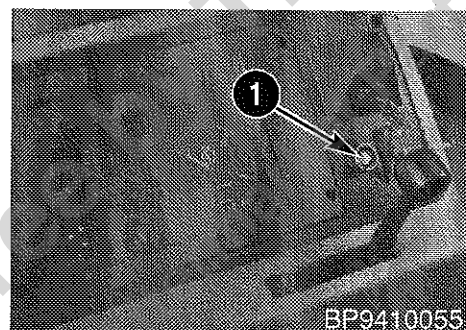

1. Ether Starting Aid Button

**NOTE:** The ether starting aid system will operate until the engine temperature goes above 12.77 °C (55 °F). The ether start aid system will operate after the engine temperature has dropped below 1.6 °C (35 °F).

**IMPORTANT:** Before you replace the ether container, read the instructions and warnings on the container. See page 164.

## Booster Battery Connection to Machine



**WARNING:** When the battery electrolyte is frozen, the battery can explode if, (1) you try to charge the battery, or (2) you try to jump start and run the engine. To prevent the battery electrolyte from freezing, try to keep the battery at full charge. If you do not follow these instructions, you or others in the area can be injured. SA033



**WARNING:** Batteries produce explosive gases. Keep sparks, flame, and cigarettes away. Ventilate when charging or using in an enclosed space. Always shield eyes when working near batteries. SA031

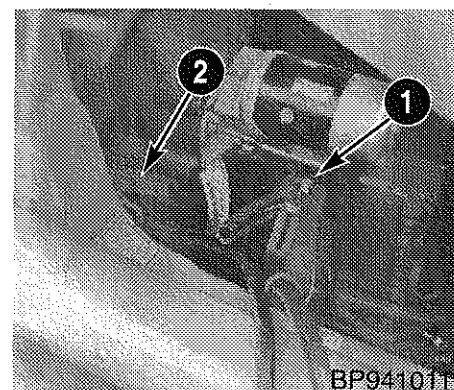

1. Positive Jumper Cable
2. Negative Jumper Cable

Two persons are required for this procedure. Make sure the person making the connection is wearing face protection.

1. Sit in the operators seat and have the other person make the connections. Make sure the booster batteries are 12 volt.
2. If using another machine for power, make sure the two machines do not touch.
3. Connect the positive (+) jumper cable to the positive (+) terminal as shown.
4. Connect the negative (-) jumper cable to the frame as shown.
5. Start the engine and have the other person disconnect the negative (-) jumper cable first and the positive (+) jumper cable last.

## Engine Coolant Heater (If Equipped)

The right side of the engine cylinder block is provided with a passage for installing a coolant heater. See your dealer for this option. Follow the heater manufacturer's instructions for installing.

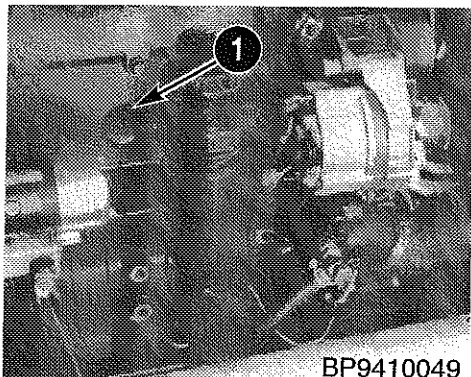

BP9410049

1. Coolant Heater Passage

## Engine Oil Heater (If Equipped)

The engine oil heater is installed on the right side of the engine oil pan. See your Case dealer for this option. Follow the heater manufacturer's instructions for installing.

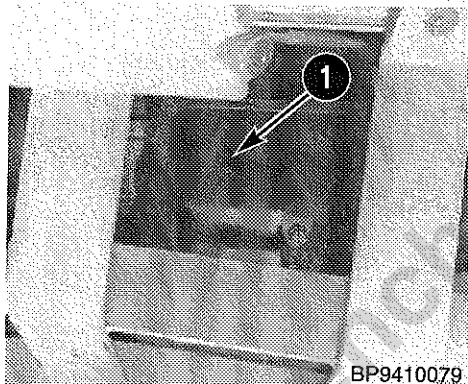

BP9410079

1. Engine Oil Heater Location

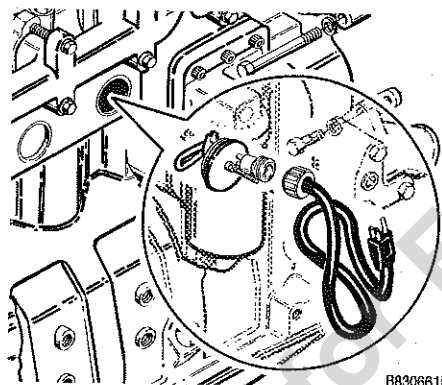

B830661M

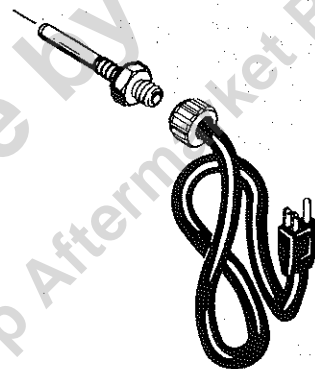

B830682J

## MACHINE OPERATION



**WARNING:** Before each period of operation, check the machine for correct operation of the steering, brakes, hydraulic controls, instruments, and safety equipment. Check the NEUTRAL position of the transmission control lever. A machine that runs correctly can prevent accidents. Make all necessary repairs or adjustments before you operate the machine.

SA040

### Adjusting the Seat

Before starting each day, adjust the position of the seat for the most comfort and fasten the seat belt.

### Before You Operate the Machine

When the engine is warm, decrease the engine speed to idle and do the following:

1. Check the instrument panel.
2. Make sure the backhoe is in the TRANSPORT position and the stabilizers are raised.
3. Raise the loader about 600 mm (two feet) above the ground and roll the bucket back against the stops.
4. Test the parking brake in an open level area. Make sure the area is clear of other persons.
  - A. Put the transmission control lever in third gear.
  - B. Apply the parking brake and shift the transmission direction control to FORWARD.
  - C. Increase the engine speed to 1500 rpm. The machine must not move.

**NOTE:** If the machine moves, adjust the parking brake. See page 48.

5. Release the parking brake and test the foot brakes in an open area on a hard level surface. Make sure the area is clear of other persons.
  - A. Move the brake pedal lock to the right to hold both pedals together.
  - B. Shift the transmission to second gear and release the parking brake.
  - C. Shift the transmission direction control to FORWARD and increase the engine speed to full throttle.
  - D. When the machine is moving at full speed in second gear, push the brake pedals and stop the machine. The machine must stop smoothly and the brake pedal effort must feel firm.

See the service manual for this machine or see your dealer if you have problems with the machine.

## Selecting Transmission Gears and Machine Direction

### Transmission

The transmission is synchronized in all gears. You can shift to any gear without stopping the machine. Before you shift gears, push the clutch cutout button. When you shift gears, always make sure the engine speed remains in the green area of the tachometer.

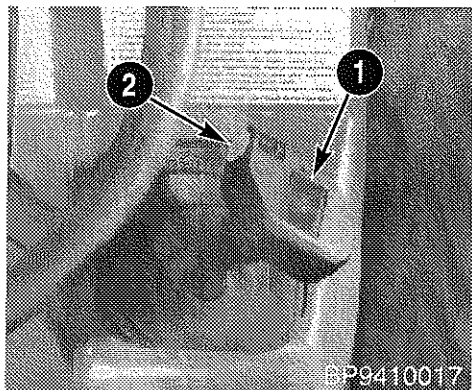

1. Transmission Shift Lever  
2. Clutch Cutout Button

### Machine Direction

For forward travel, lift up the direction control lever and push completely forward. To travel in reverse, lift up the direction control lever and pull completely rearward. The center position is NEUTRAL. The transmission direction control lever must be in the NEUTRAL position before you can start the engine.

**NOTE:** For Smooth operation before you change directions, reduce the engine speed.

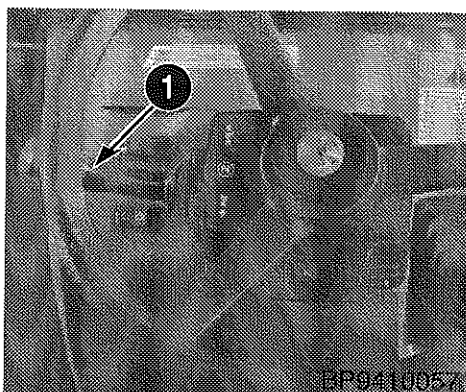

1. Direction Control Lever

### Differential Lock

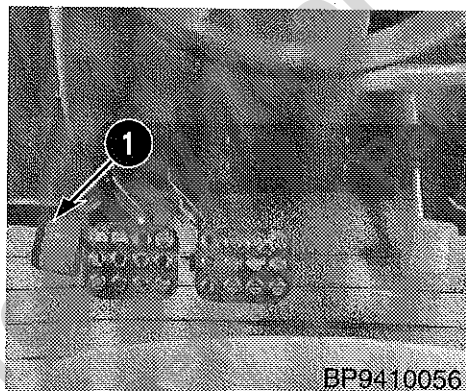

1. Differential Lock Pedal

The differential lock gives equal power to both rear wheels and is used in conditions where traction is poor.

## Differential Lock Operation Working on a Hill

1. Before engaging the differential lock make sure that one of the rear wheels is not spinning freely.
2. Apply a light steady pressure to the differential lock pedal until it engages and hold it down. The differential lock is now engaged.

**NOTE:** The differential lock will not fully depress until differential pins in the rear axle align and engage. Some slight wheel speed differentiation can be required to allow the pins to align.

3. To disengage the differential lock, release the differential lock pedal.

**NOTE:** The differential lock will disengage any time the differential lock pedal is released.

Before you work the machine on a hill, always put the transmission in a lower gear and test your brakes. DO NOT let the machine move down the hill with the transmission in NEUTRAL. DO NOT let the engine speed increase greater than 2500 rpm. Use caution if you must use the clutch cutout when you are digging with the loader on a hill.

**WARNING:** Hillside operations can be dangerous. Rain, mud, snow, ice, loose gravel, soft ground, etc., change the ground conditions. You must make a judgment if your machine can be safely operated on any hillside or ramp. SB013

**WARNING:** Excessive speed can cause loss of machine control. Do not coast down a hill with a transmission in NEUTRAL or let the engine speed increase to more than 2500 RPM. Before operating or driving on a hill, always shift to a lower gear. You or others around you can be injured. SD056

## Four Wheel Drive Operation (If Equipped)

**IMPORTANT:** When the front drive axle is engaged, drive the machine in first or second gear only.

The front drive axle is engaged and disengaged by a rocker switch. To engage the front drive axle, push the rocker switch emblem. To disengage the front drive axle, push the opposite end of the rocker switch down.

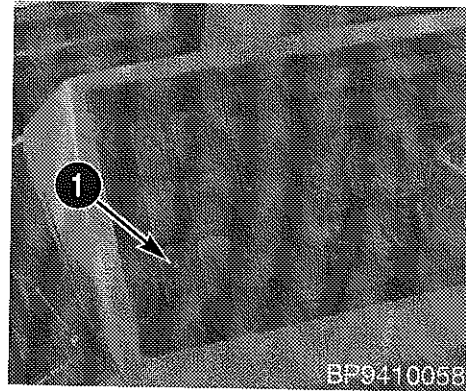

1. To Engage

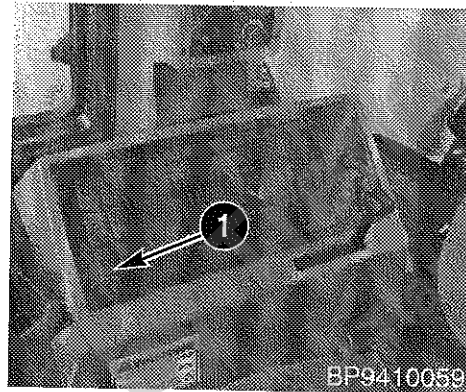

1. To Disengage

## Parking the Machine

1. When the work day is finished, make sure the machine is parked on level ground. The machine must be on level ground before you do scheduled maintenance.

**IMPORTANT:** If you must temporarily park the machine on a hillside, put the front of the machine toward the bottom of the hill. Make sure the machine is behind an object that will not move.

2. Lower the loader bucket to the ground.
3. Apply the parking brake and shift the direction control lever to NEUTRAL.
4. Move the backhoe into the TRANSPORT position or lower the backhoe bucket to the ground and stop the engine.



**WARNING:** Jumping on or off the machine can cause an injury. Always face the machine, use the hand rails and steps, and get on or off the machine slowly.

SA038



## TOWING A DISABLED MACHINE

**WARNING:** Personal injury or death can result when you tow a disabled machine incorrectly. Read the following recommendations. CM100

If your machine is disabled, you must make a judgement if the machine can be moved without more damage. If possible, repair the machine at the job site.

### Engine Running

1. Apply the parking brake and raise the loader bucket. Put the backhoe in the TRANSPORT position.
2. Shift the direction control lever and transmission control to NEUTRAL.
3. Attach a rigid drawbar to the machine. Make sure the towing machine has enough power and braking ability to move and stop both machines.
4. Release the parking brake.
5. No riders - keep all other persons completely out of the area.
6. Tow the disabled machine up to 16 km/h (10 mph). Do not exceed this speed.

### Engine Stopped

1. Apply the parking brake and raise the loader bucket. Put the backhoe in the TRANSPORT position.
2. Raise the loader, backhoe, and backhoe stabilizers or rear attachment as required. Use a hoist and actuate the control for each attachment to the RAISE position as you lift. Install loader lift arm support strut as required.
3. Attach a rigid drawbar to the machine. Make sure the towing machine has enough power and braking ability to move and stop both machines.
4. Release the parking brake.
5. No riders - keep all other persons completely out of the area.
6. Tow the disabled machine up to 16 km/h (10 mph). Do not exceed this speed.

## Transporting the Machine on a Trailer

**WARNING:** The machine can slip and fall from a trailer or ramp and cause injury or death. Make sure the trailer and ramp are not slippery. Remove all oil, grease, ice, etc. Carefully move the machine off or onto the trailer with the machine centered on the trailer and ramp. SB042

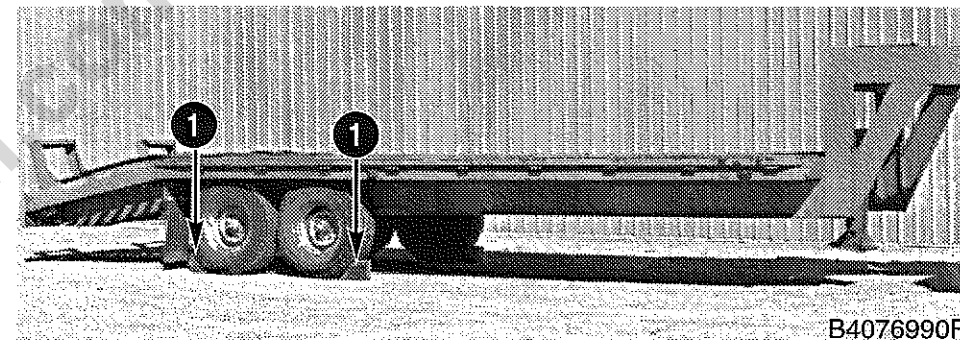

1. Wheel Blocks

**NOTE:** The machine shown in the following procedure may be different from your machine. The procedure is the same.

You must know the rules or laws for safety that are used in each area that you will be in. Make sure that your truck and trailer are equipped with the correct safety equipment. Park on a level surface.

1. Put a block at the front and rear of the trailer wheels.
2. Put the backhoe in TRANSPORT, fasten your seat belt, shift the transmission to 1st gear, and slowly drive the machine onto the trailer.
3. Lower the loader bucket onto the trailer, shift the direction control lever to NEUTRAL and apply the parking brake.
4. Lower the backhoe bucket or rear attachment to the floor of the trailer if possible.

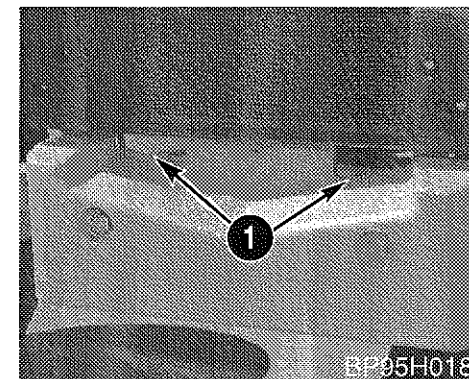

1. Tie Down Location - Front Chassis

9. Measure the distance from the ground to the highest point of the machine. You must know the clearance height of the machine.

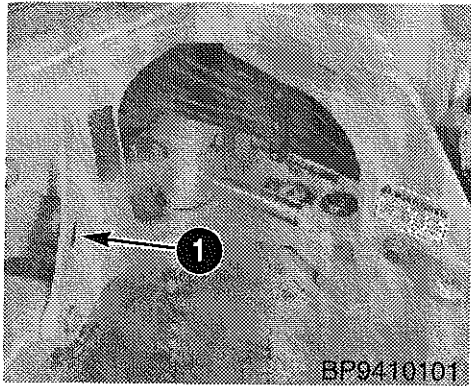

1. Tie Down Location - Backhoe

10. After you have driven a few miles, stop the truck and check your load. Make sure the chains are still tight and that the machine has not moved on the trailer.

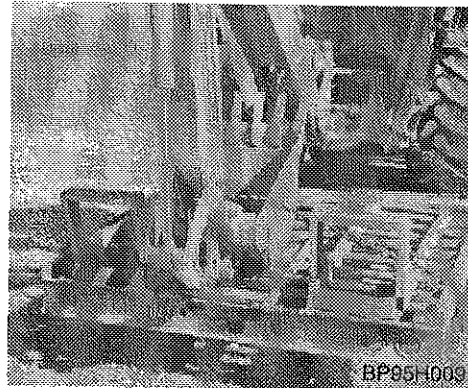

**UNLOADING** - After the chains and blocks are removed from the machine, put the backhoe in the TRANSPORT position or raise the rear attachment. Fasten your seat belt, shift the transmission to 1st gear, release the parking brake and drive slowly off the trailer.

## OPERATING IN COLD WEATHER

Cold weather conditions cause special problems. During these conditions, your machine will require special attention to prevent serious damage. Cold weather maintenance will extend the service life of your machine.

### 1. BATTERY AND ELECTRICAL

**SYSTEM:** Clean the battery and make sure the battery(ies) is at full charge.

**NOTE:** A fully charged battery at  $-17^{\circ}\text{C}$  ( $^{\circ}\text{F}$ ) has only 40 percent of the normal starting power. Then, when the temperature decreases to  $-29^{\circ}\text{C}$  ( $-20^{\circ}\text{F}$ ), the battery has only 18 percent of the power remaining.

If you add water to the battery(ies) and the temperature is below  $0^{\circ}\text{C}$  ( $32^{\circ}\text{F}$ ), make sure you charge the battery(ies) or run the engine for approximately two hours. This procedure will prevent battery freezing.

Inspect the battery cables and terminals. Clean the terminals and put a coat of grease on each terminal to prevent corrosion.

2. **LUBRICANTS:** Use the correct viscosity oil in each component. As an example: SAE 30 engine oil at  $0^{\circ}\text{C}$  ( $32^{\circ}\text{F}$ ) increases the starting load by about 250 percent. Make sure you follow the recommended oil and filter service as shown in this manual.

3. **FUEL SYSTEM:** Check with your fuel supplier for the correct cold weather fuel. Engine power will be reduced if wax particles are in the fuel filters.

Make sure to check for water in the fuel system. Cold temperatures can cause water to collect in the fuel tank. Check the main fuel filter for water every 50 hours of operation. If no water is found, extend the interval. If water is found, check the fuel tank.

4. **COOLING SYSTEM:** Check the coolant mixture before you operate in cold temperatures. A mixture of 50% ethylene glycol and 50% water must be used in this machine. This mixture is used if the lowest ambient temperature is above  $-37^{\circ}\text{C}$  ( $-34^{\circ}\text{F}$ ). If the ambient temperature is lower, adjust the mixture. It is recommended that ethylene glycol and water be used in your machine all year.

5. **COLD TEMPERATURE STARTING AIDS:** See your dealer for extra starting aids such as battery heater, ether cold start fluid, coolant heater, engine oil heaters, etc. See pages 69 through 72.

6. **GENERAL:** Before you operate, move the machine slowly in LOW gear. Then, stop the machine and actuate the loader or backhoe controls for about ten minutes or until all cylinders work correctly.

## OPERATING IN HOT WEATHER

To prevent damage to the machine, do the following:

1. Keep the coolant at the correct level in the coolant reservoir and in the radiator. See page 144.
2. Test the radiator cap before hot weather starts. Replace the cap as required.
3. Clean all dirt and debris from the radiator and engine area.
4. Check the condition of the fan drive belt.
5. Use lubricants of the correct viscosity.
6. Use the correct solution of ethylene glycol and water in the cooling system.
7. Check the precleaner more frequently during extreme dust conditions.
8. Remove the ether starting aid can. See page 164.

## LOADER OPERATION



**WARNING:** When you lower a loaded bucket, material can spill out if you do not manually roll back the bucket. The self-leveling feature does not roll back the bucket automatically when the loader is lowered. Other persons in the area can be injured if material spills from the bucket when the loader is lowered.

CM101

This information for loader operation does not include all possible conditions. This is basic information that you need to operate the machine.

If you are a new operator, always operate in a clear area at decreased engine speed.

### Safety When You Work

Be a careful operator. You can prevent accidents. Fasten the safety belt before you start the engine.

### Clutch Cutout Button

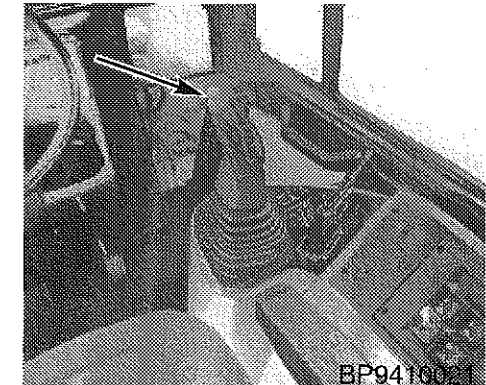

BP9410021

Push the clutch cutout button to allow the engine to increase speed and supply the loader with more hydraulic oil for greater loader power and faster control function. When you push the clutch cutout button, the transmission is disengaged from the drive wheels. Release the clutch cutout button to engage the transmission power. The machine can roll free when the clutch cutout button is pushed. If required, use the brake to stop the machine.



BP9410068

Operator and Seat in Correct Position for Loader Operation

### Standard Bucket Level Indicator

The bucket level indicator has two pointers on the bucket links. The bucket is level on the ground when the two pointers are opposite each other. See the following photograph.

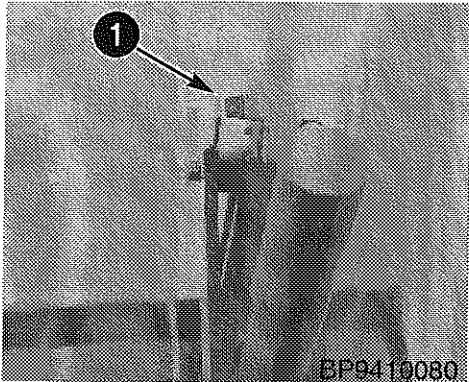

1. Bucket Level Indicator

### Bucket Position Indicator for the 4-In-1 Bucket

The bucket position indicator is located on the bucket links. This shows you the correct bucket angle when you use the bucket as a scraper, loader, dozer, or clam. Put the loader bucket one foot (0.3 m) above the ground and tilt the bucket to the desired position.

### Clam Depth Indicator for the 4-In-1 Bucket

The clam indicator is located on the right side of the bucket. This indicator is used when the bucket is in the scraper position. The bucket opening or "depth of cut" is shown on this indicator. The 4-In-1 bucket can make a cut up to 102 mm (four inches) in depth.

### 4-In-1 Bucket Indicators

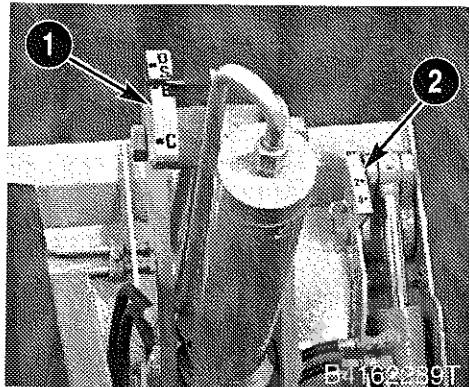

1. Bucket Position Indicator  
2. Clam Depth Indicator

### Scraper

Tilt the bucket to the scraper position on the indicator and open the clam to the desired depth of cut.

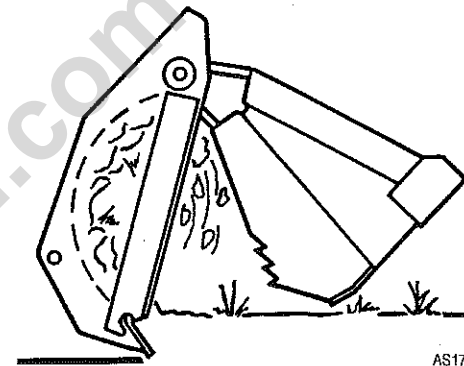

### Dozer

Put the bucket in the position shown and open the clam completely.

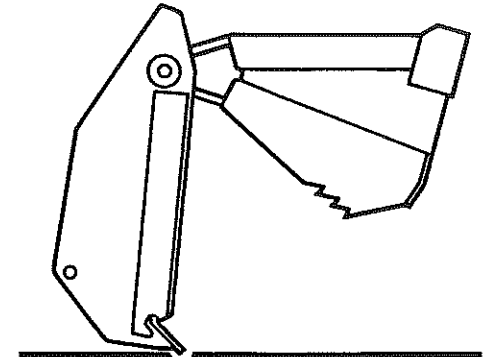

### Standard Bucket

Close the clam and the bucket is a standard bucket.

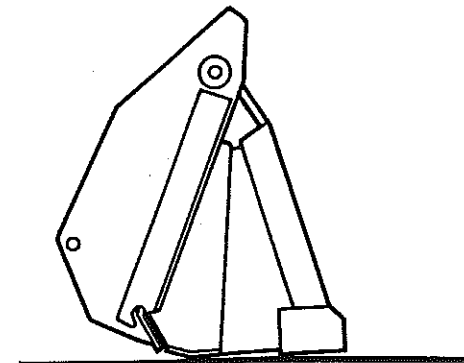

### Clamshell

Put the bucket over the material to be moved. Close the clam on the material to be moved.

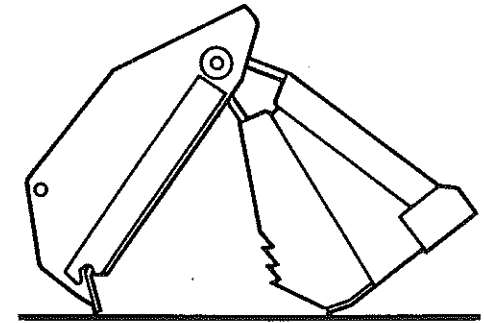

## Return-To-Dig

After you dump the load, use the return-to-dig to put the bucket in position for another dig cycle.

The return-to-dig uses both the FLOAT and the ROLLBACK positions. To operate, put the lift arm control in the ROLLBACK position and the FLOAT position. The bucket will roll backward until the bottom of the bucket is level. Then, the bucket will stop automatically.

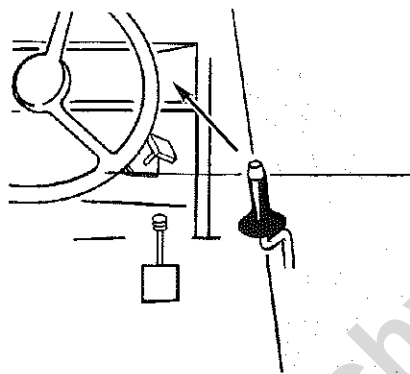

B9410135

MOVE THE CONTROL LEVER TO THE FLOAT AND ROLLBACK POSITIONS FOR RETURN-TO-DIG

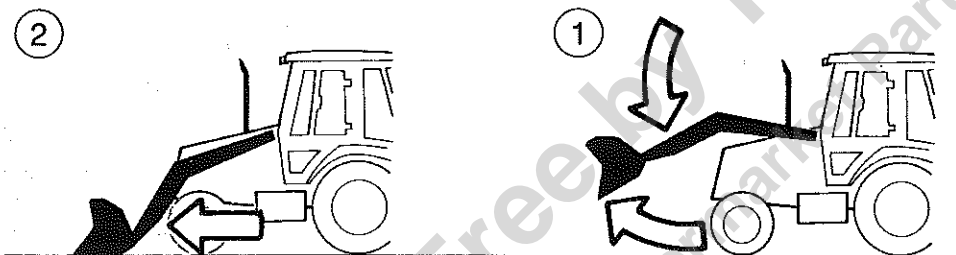

B9410267

## Job Layout

Set up the work cycle as short as possible. Truck positioning is very important for fast cycles.

Spend a few minutes leveling off the work area, if necessary. Smooth runways for the machine and a level parking area for trucks will speed up the job.

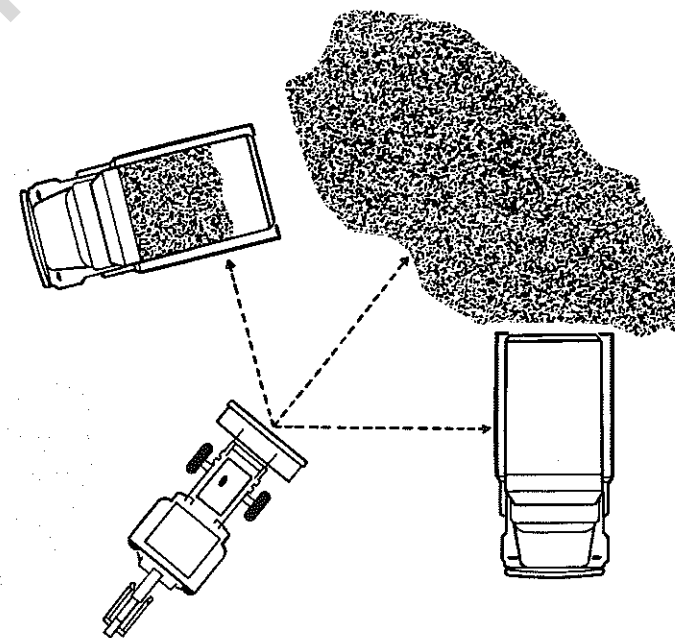

B902464J



**WARNING:** Operating a loader with a full bucket on a hillside can cause the machine to roll over. If possible, avoid turning the machine and always move forward up the hill and back down. Always keep the load low. If you do not follow these instructions, you can be injured or killed.

SA058



**WARNING:** When you operate the machine, keep the loader bucket as low as possible. This low position gives better balance and permits you to see more clearly. If the bucket is full and you move the machine over ground that is rough or surfaces that can cause the machine to slide, always operate at slow speed. If you do not use this procedure, the machine can go out of control and roll-over.

SA041

## Lifting with the Loader

If you lift a load with the loader, be very careful. This machine is NOT a crane.

**IMPORTANT:** Make sure that you use rigging equipment that has the capacity to lift the loads that you will be moving. Always check the rigging equipment each day for damaged or missing parts. Be sure no other persons are under the load as you move it.

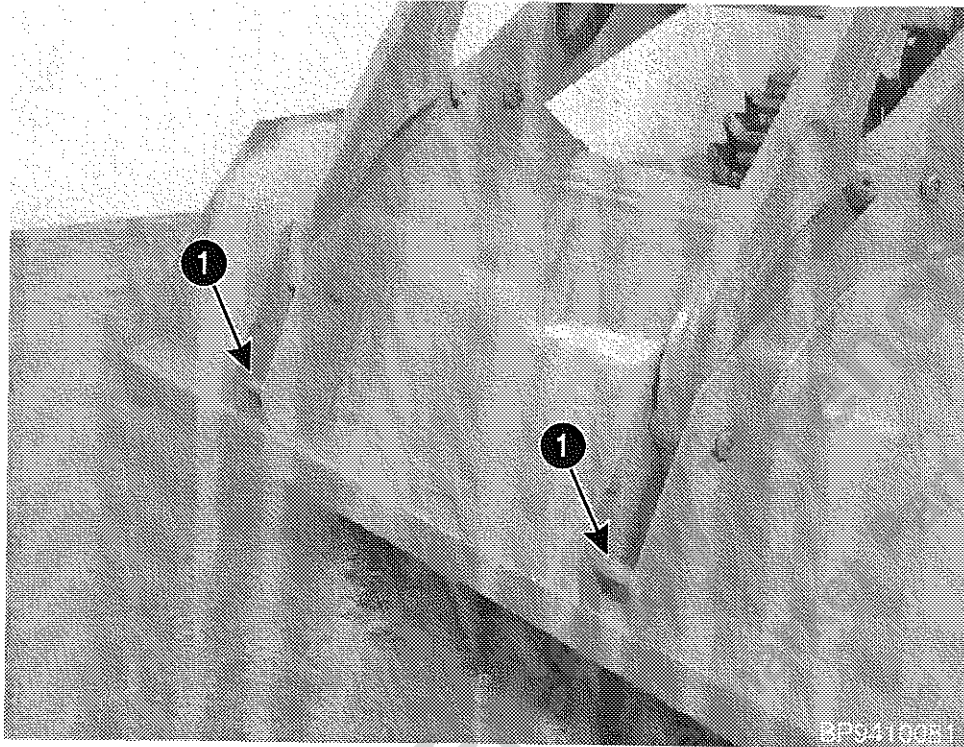

1. Lifting Points.

## BACKHOE OPERATION

### Safety When you Work

Be a careful operator; you can prevent accidents. Read the following information.



**WARNING:** Always know the location of all workers in your area. Warn them before you start working the machine. Always keep all other persons away from your area. Serious injury or death can result if you do not follow these instructions.

SA015



**WARNING:** Uncontrolled machine movement can injure. Before you turn the operators seat around to the BACKHOE operating position, shift the direction control lever and transmission control to NEUTRAL and apply the parking brake.

SA050



Operator in Correct Position To Operate Backhoe

### General

The backhoe will dig more material in less time when a smooth, short dig cycle is used. Keep each dig cycle smooth.

When you force the bucket to dig a load that is too large, you will cause a "hydraulic stall" (dipper control lever pulled back and the bucket is not moving). The main relief valve of the hydraulic system will make a noise when "hydraulic stall" occurs. "Hydraulic stall" will cause: (1) cycle times to be longer, (2) the temperature of the hydraulic oil to increase, and (3) increases fuel consumption.

### Stabilizer Pads

If you dig next to a building, wall etc., change the position of the stabilizer pads. See the photographs on the following page. Do the following steps:

1. Remove a retaining ring from the pin on each stabilizer pad.
2. Use a hammer and drift. Remove each pin.
3. Put the stabilizer pads in the position shown. Install the pins and retaining rings.

**IMPORTANT:** Always position the stabilizer pads for maximum stability when you are not operating the backhoe next to a wall, building, etc.

**IMPORTANT:** Be careful when you swing the backhoe completely to the side. In some positions, the backhoe can contact the stabilizers and can cause damage.

### Standard Two Position Stabilizer Pads

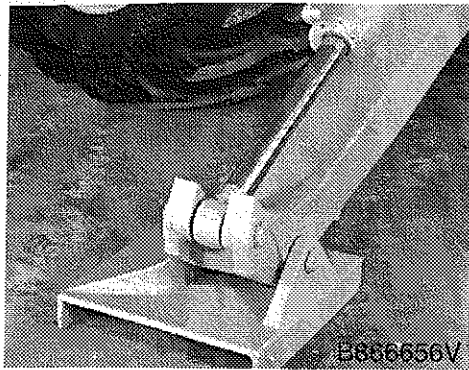

Working Next to Buildings

B866656V

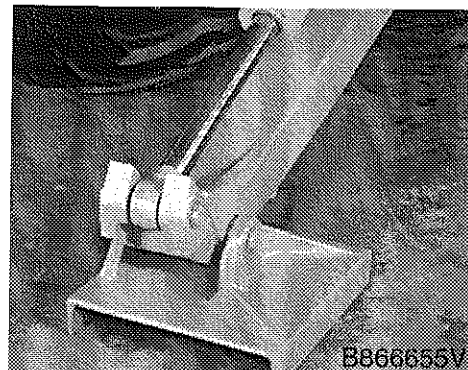

Position for Maximum Rear Stability and Minimum Width for Traveling

B866655V

### Cemetery Stabilizer Pads with Rubber Pads

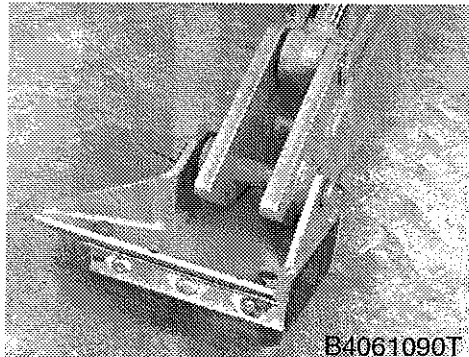

Working Next to Buildings

B4061090T



Position for Maximum Rear Stability and Minimum Width for Traveling

B4061190T

### Combination Flip-Over Stabilizer Pads

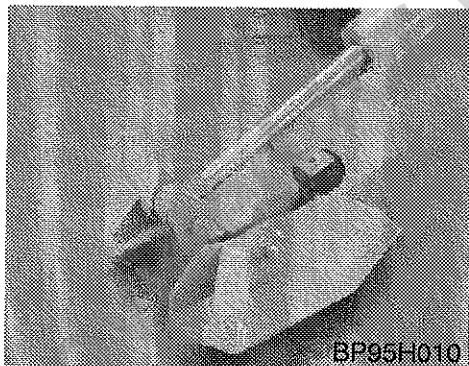

Rubber Pads Down

BP95H010



Dirt Pads Down

BP95H011

### Before You Dig with the Backhoe

1. Remove the swing lock pin.



BP9410071

2. Use hand rails and steps.



BP9410072

3. Make sure the direction control is in NEUTRAL.

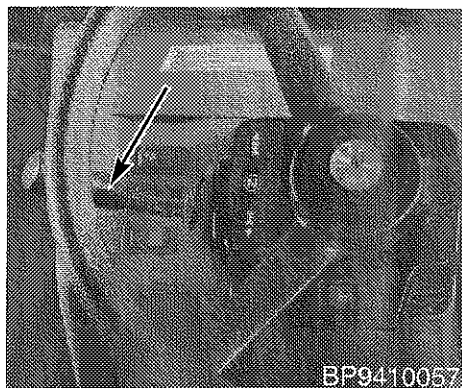

BP9410057

4. Make sure the transmission control is in NEUTRAL.

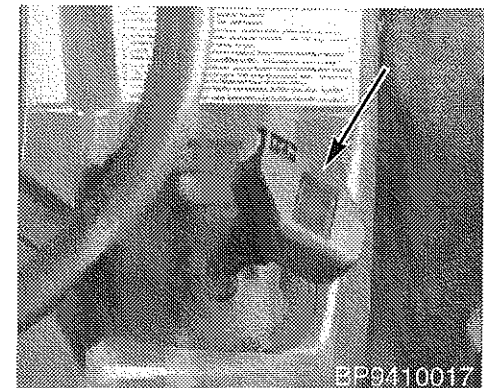

BP9410017

5. Make sure the parking brake is applied.

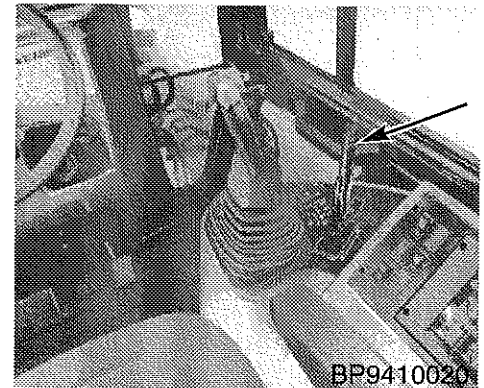

BP9410020

6. Start the engine.
7. Dump the loader and lower the bucket to the ground. Raise the front wheels above the ground.

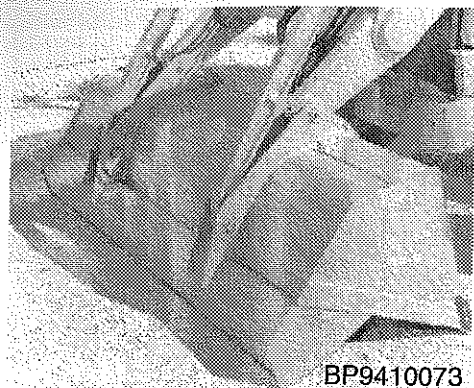

8. Turn seat around for backhoe operation and adjust the seat.
9. Increase the engine speed.

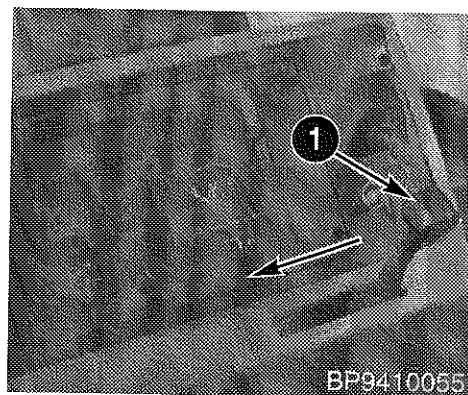

1. Hand Throttle

**NOTE:** If required, bottom of bucket can be positioned flat on the ground.

**WARNING:** Put the stabilizers in the OPERATING position before you lower the boom and extend the dipper. The front of the machine can raise above the ground and cause an accident if the stabilizers are not down in the OPERATING position.

 Before you raise the stabilizers from the OPERATING position, put the backhoe bucket on the ground or raise the boom and retract the dipper. SA060

10. Lower the stabilizers. Raise and level the machine with the rear tires above the ground.

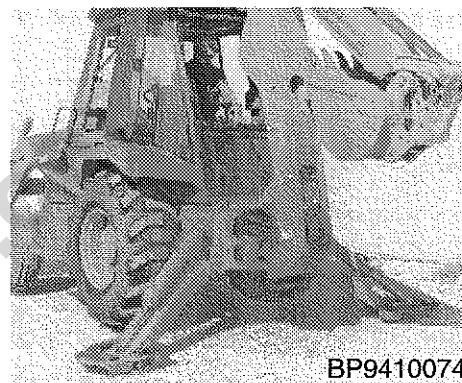

11. Move the backhoe out of the transport position.

- A. Push the boom control (1) forward. At the same time push down and hold the boom release pedal (2) with your foot.

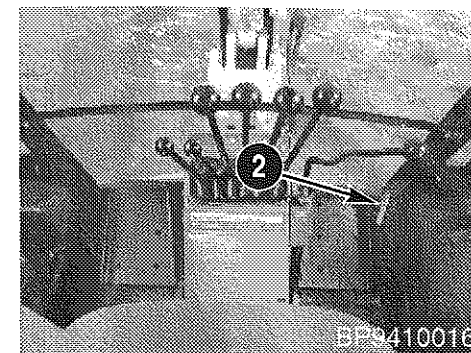
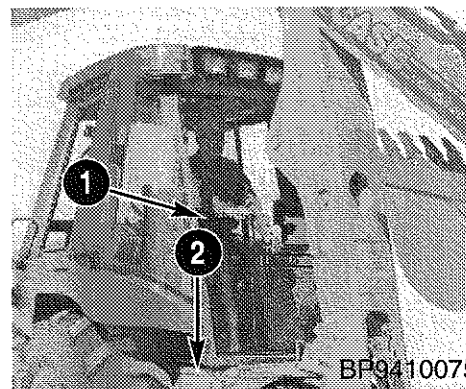

- B. Pull the boom control lever (1) to the rear to move the boom forward (over center).

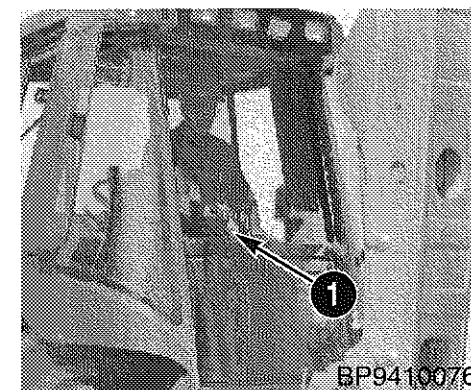



**WARNING:** Before each period of operation, check the backhoe for correct function of each control. A backhoe that operates correctly can prevent accidents. Make all necessary repairs or adjustments before you operate the backhoe.

SA017



**WARNING:** Do not dig the ground under the backhoe stabilizers. The machine can fall into the excavation if the bank falls in.

SA063



**WARNING:** When you operate the backhoe on the side of a hill, (1) make the machine level with the stabilizers and (2) put the earth from the trench on the highest side of the trench. Failure to follow these instructions can cause injury.

SA064

## Backhoe Bucket Digging Positions

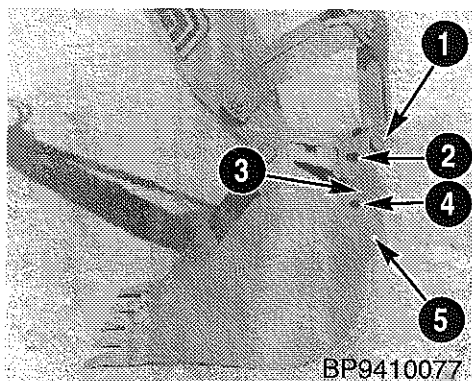

1. Coupler Position 1
2. Coupler Position 2
3. Bucket Hole 1
4. Bucket Hole 2
5. Bucket Hole 3

You can change bucket rotation as the digging conditions change. Four positions are available.

1. 160° Rotation - General use, use coupler position 1 and bucket hole 2.

2. 161° Rotation - Maximum bucket power, use coupler position 1 and bucket hole 1.

3. 185° Rotation - Good for straight wall trenching and is the best position to hold the maximum amount of material, use coupler position 2 and bucket hole 1.

4. 185° Rotation - Rotates the bucket out ten more degrees to permit straight wall trenching closer to the machine, use coupler position 2 and bucket hole 2.

**NOTE:** Other degrees of rotation are available with the installation of a bucket link kit. The bucket link kit also allows the use of a wider range of backhoe attachments. See your dealer for more information.

## Extendahoe Lock Pin

Before you work the Extendahoe, put the backhoe in the position shown and remove the Extendahoe lock pin. Put the pin in the storage hole during operation.

Then, before transport, lock the extendable dipper in the retracted position with the lock pin.

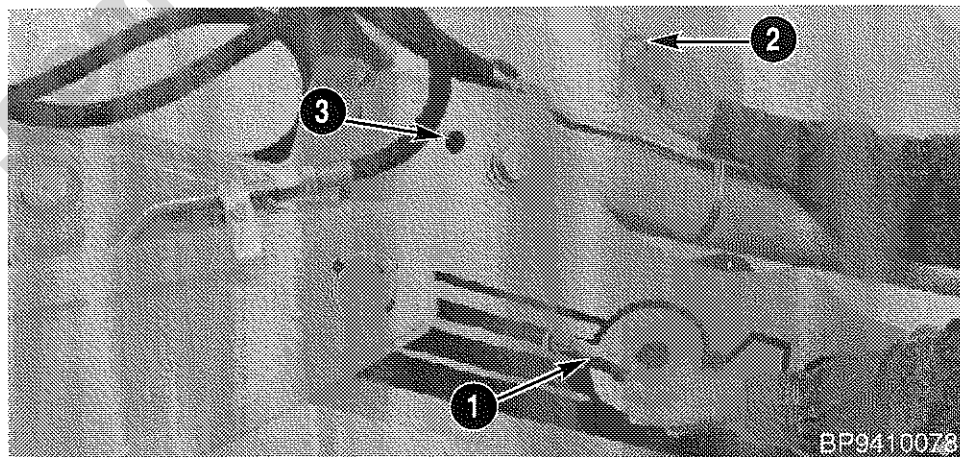

1. Pin in Transport Lock

2. Lock Pin

3. Storage Hole

## Backhoe Danger Area



**WARNING:** Before you operate the backhoe in an area where your visibility is reduced, such as next to a building, etc., always install a guard rail and warning signs to keep other persons away from your machine.

SA062



**WARNING:** A working backhoe can injure or kill. Before you start, always make sure that all persons are away from the DANGER AREA.

SA061

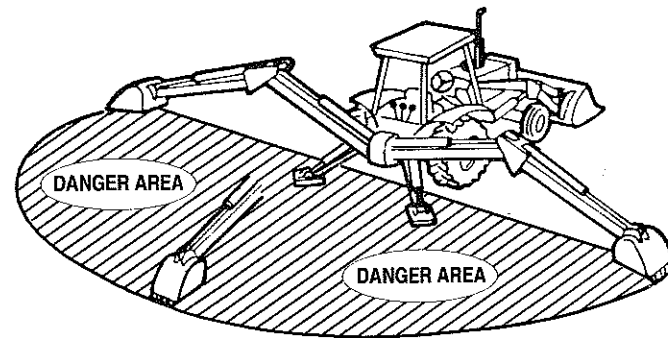

B890879J

## Digging with the Backhoe



**WARNING:** Always know the location of all workers in your area. Warn them before you start working the machine. Always keep all other persons away from your area. Serious injury or death can result if you do not follow these instructions.

SA015

### Filling the Bucket

Fill the bucket by moving the dipper in. Keep the bottom of the bucket parallel with the cut. Let the bucket teeth and cutting edge cut through the ground like a knife blade. The type of material that you dig determines the depth of the cut.

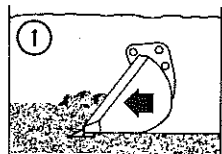

CORRECT

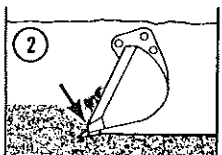
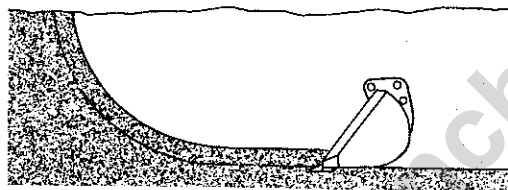

WRONG

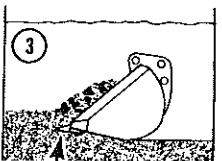
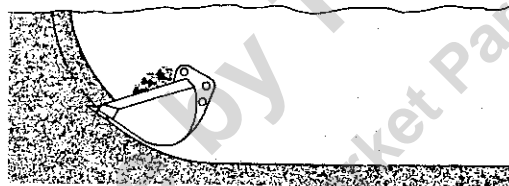

WRONG

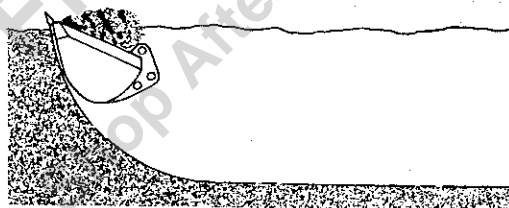

CORRECT TRENCHING METHOD

B8400068.J

**IMPORTANT:** Do not back fill a trench with the backhoe by swinging the bucket against the soil.

## Moving the Machine Forward When You Are Digging on Level Ground

You can use the backhoe to move the machine forward as you trench.

1. Make sure the front wheels of the machine are STRAIGHT forward.
2. Decrease the engine speed to 1000 rpm. Make sure the parking brake is released and the transmission is in NEUTRAL.
3. Raise the boom and retract the dipper. Move the boom as required to put the bucket teeth on ground that is firm. Lower the backhoe bucket to the ground.
4. Raise the stabilizers and loader bucket about 300 mm (one foot) above the ground.
5. Use the boom and dipper to move the machine. Slowly move the dipper out. At the same time, lower the boom.
6. At the new position, lower the stabilizers and loader bucket to the ground and level the machine.
7. Apply the parking brake.

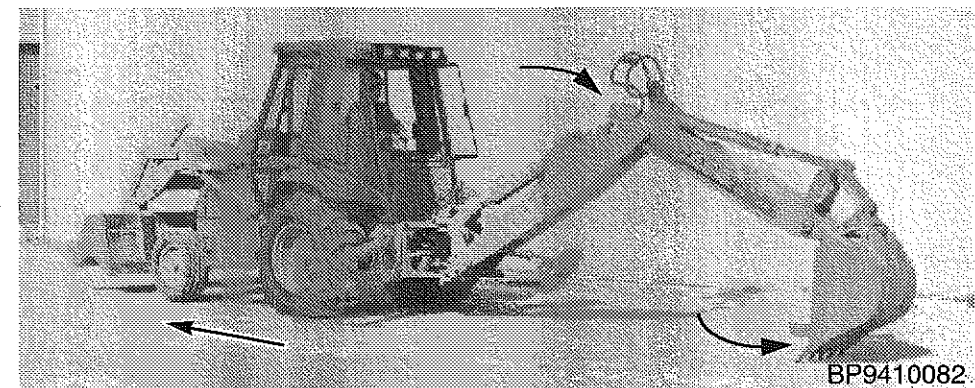

BP9410082

Moving the Machine Forward On Level Ground

## Moving the Machine Forward When You are Digging on a Hill



**WARNING:** Be careful when you dig on the side of a hill. When you move the machine forward, the machine can go out of control and turn over. You must be in the seat (seat in the loader position) when you drive the machine forward. Always engage the parking brake and shift the transmission and direction control to NEUTRAL before you operate the backhoe.

SA065

## Putting the Backhoe in the Transport Position

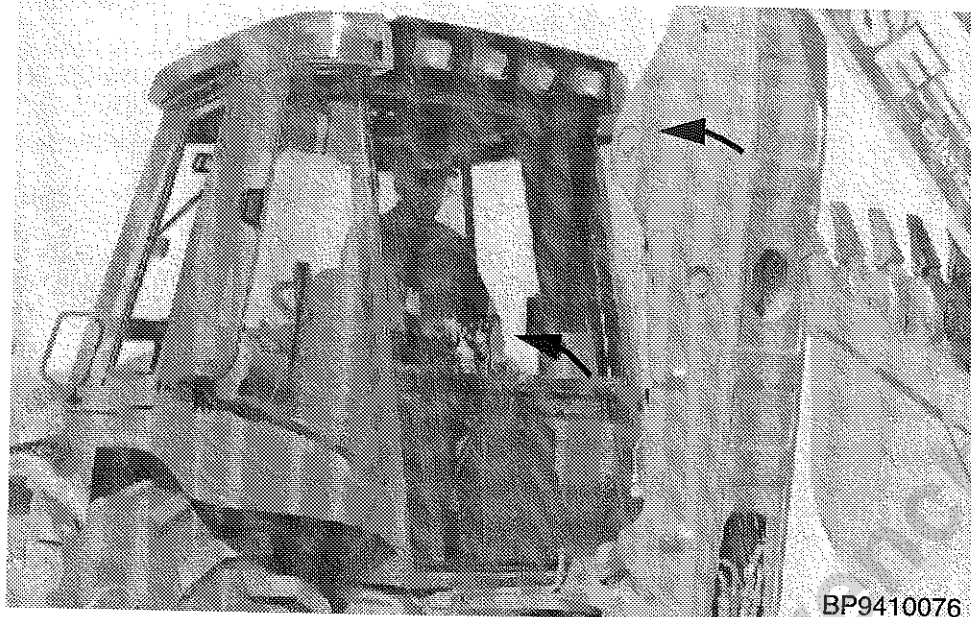

BP9410076

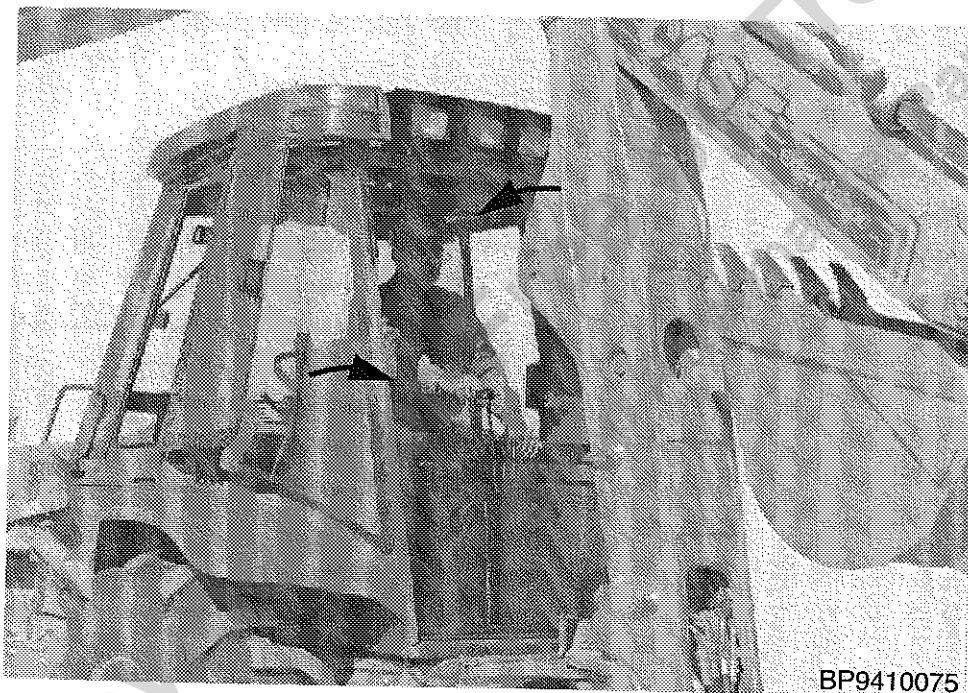

BP9410075

Put the backhoe in transport before you use the loader or before you move the machine on a road or highway. See photos on page 98.

1. Make sure the direction control lever and transmission control are in **NEUTRAL**.
2. Make sure the parking brake is applied.
3. Use the swing controls and put the backhoe bucket straight behind the machine.
4. If your machine has an extendable dipper, retract the dipper and install the extendahoe lock pin. See page 95.
5. Make sure the stabilizers are down and the rear wheels are above the ground.
6. Use the hand throttle and run the engine at about 900 rpm.
7. Retract the dipper and curl in the bucket.
8. During this next procedure, the backhoe boom will be moving toward you past the vertical position.
  - A. Pull the boom control lever rearward.
  - B. When the boom reaches the vertical position, rapidly push the boom control lever forward. The boom will continue to move toward you until the boom stop is reached.

**NOTE:** The boom lock will automatically engage. The boom, dipper and bucket are now in the **TRANSPORT** position.

9. Raise the stabilizers completely. Decrease the engine speed to idle.
10. Turn the operator's seat to the loader operating position.
11. Stop the engine.
12. Install the swing lock pin.

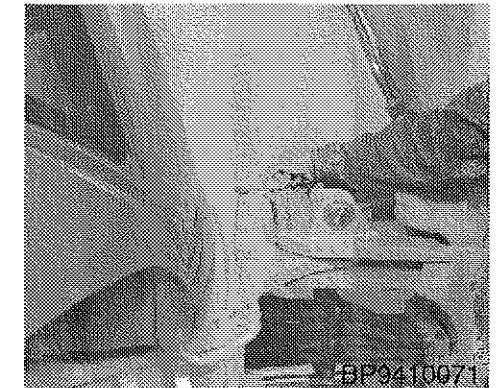

BP9410071

13. Install a Slow Moving Vehicle sign on the backhoe bucket link.
14. Start the engine and raise and rollback the loader bucket. Make sure the bucket is at least 457 mm (18 inches) above the ground. See photograph on next page.
15. Shift the transmission to the desired gear, release the parking brake and shift the direction control lever to **FORWARD**.

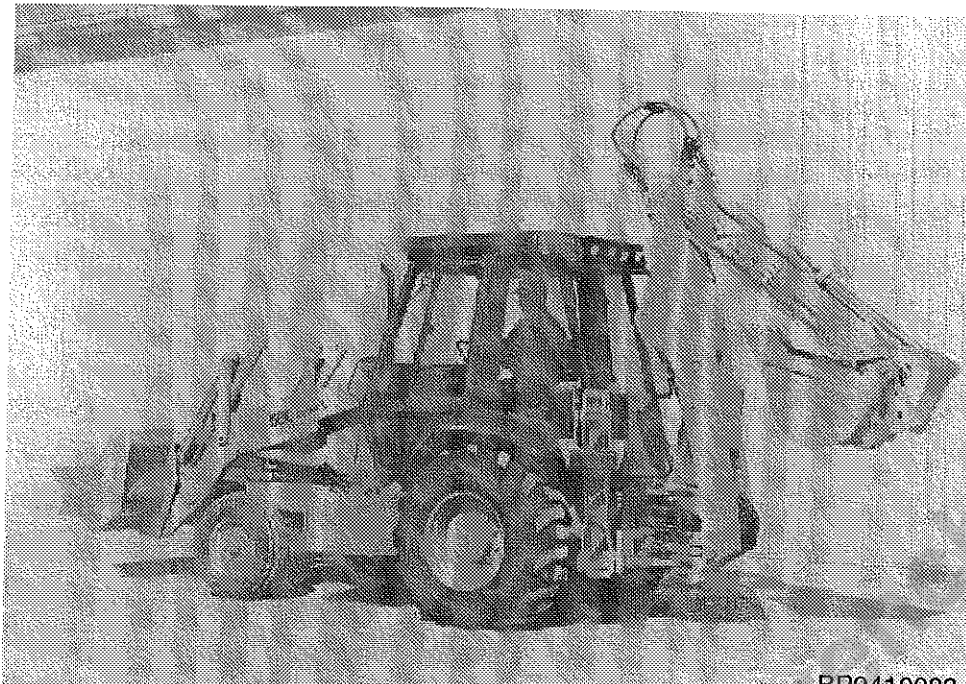

BP9410083

Loader and Backhoe in the Transport Position

## Frost Point

The Frost Point is used to break frozen ground. Use the following procedure:

1. Start with the frost point as close to the machine as possible.
2. Put the frost point in a vertical position.
3. Lower the boom to push the frost point into the ground.
4. Pull the dipper control lever to the IN position and the bucket control lever to the LOAD position. This procedure is almost the same as filling the backhoe bucket.
5. After the frost is loose, move about 0.3 m (one foot ) to the side. Do the same procedure again.

**NOTE:** Break only as much frost as you can dig in one day. Freezing can occur and you will have to break the frost again in the same area.

## Case Coupler



**WARNING:** Machine movement without an operator can cause injury or death. If you must service this machine with the engine running, have another person help you and follow the instructions in the operators manual or service manual. Do not leave the machine when the engine is running.

SA066

**NOTE:** The machine shown in the following procedure may be different from your machine. The procedure is the same.

1. Make sure the bucket or attachment has a Case Coupler pin installed.
2. Park the machine on a level surface, lower the stabilizers to the ground and level the machine. Make sure all persons are away from the machine.
3. Rotate the bucket out as shown.

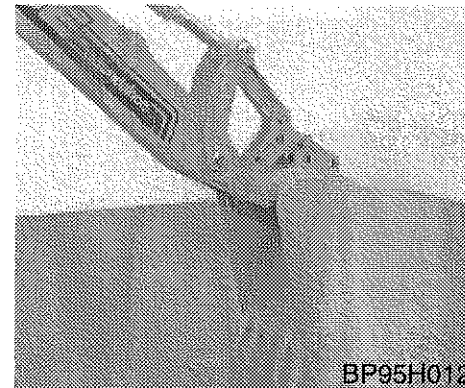

BP95H012

4. Remove the snap ring and the bucket pin.

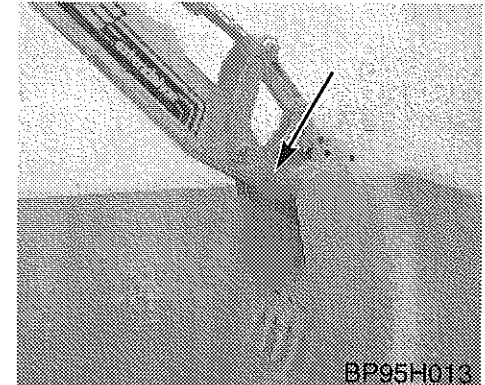

BP95H013

5. Rotate the bucket out and lower to the ground.

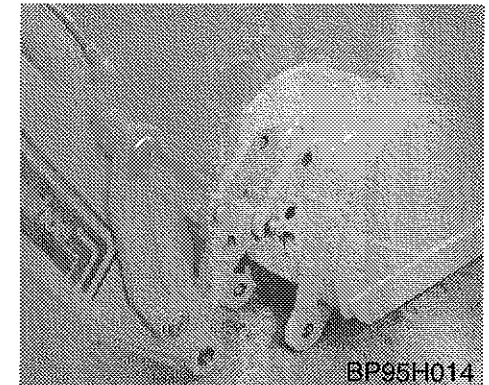

BP95H014

6. Rotate the coupler out of the bucket.
7. Pick up the next bucket and raise the boom.

**IMPORTANT:** Do not use the boom to move the machine unless a bucket is attached. Damage to the coupler may occur.

**IMPORTANT:** Make sure the hook engages the bucket pin correctly. Damage to the hook can occur if you rotate the hook between the pin and bucket back.

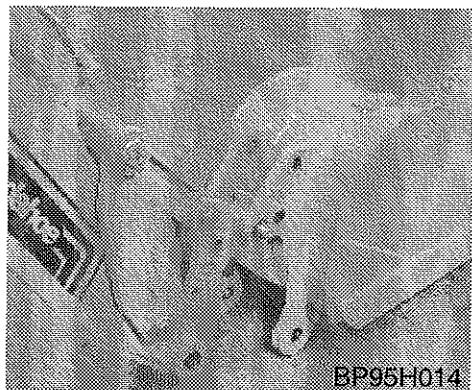

8. Retract the bucket cylinder until the bucket starts to rotate out. Install the bucket pin.

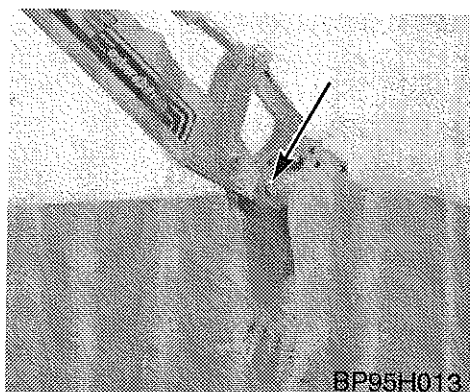

9. Install the snap ring.

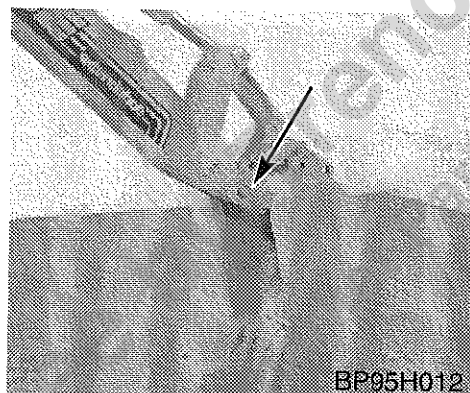

## Lifting with the Backhoe

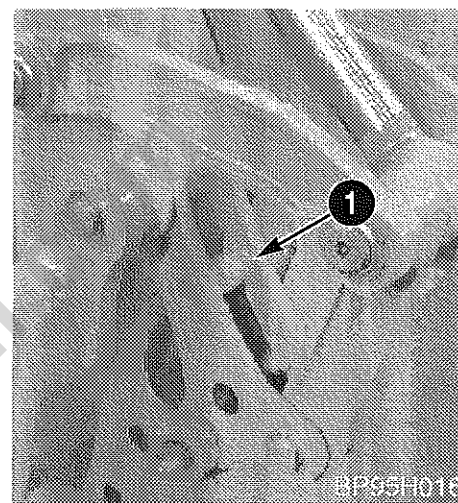

1. Lifting Crossbar

**NOTE:** Attach the sling to this crossbar.

**IMPORTANT:** Make sure that you use rigging equipment that has the capacity to lift the loads that you will be moving. Always check the rigging equipment each day for damaged or missing parts. Be sure no other persons are under the load as you move it.

**WARNING:** Do not use the hook end of the coupler when lifting loads. The sling can come out of the coupler and the load can fall, injuring others in the area. SA079

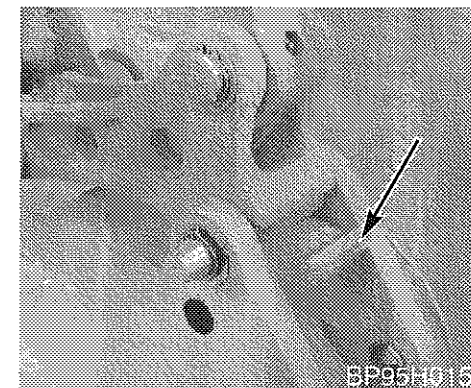

1. Hook End of Coupler

The backhoe is NOT a crane. For this reason, always be very careful when you lift a load with the backhoe. Use the backhoe lifting charts in the specifications section of this manual and read the instructions below before you lift a load with the backhoe.

1. Know and understand each signal from the signalman before you start. See pages 30 through 33.
2. Always know the location of all persons in your working area.

3. Lower both stabilizers and raise the machine so that both rear tires are about 25 to 50 mm (one to two inches) above the ground. Make sure the machine is level.

**NOTE:** *If the ground is soft, put a wide pad (wood boards) under each stabilizer pad.*

4. Dump and lower the loader bucket to the ground.
5. Connect a hand line to the load before you start. Make sure the person holding the hand line is away from the load.
6. Test the lift capacity before you start your job:
- A. Put the machine close to the load.
- B. Use a cable or sling to fasten the load to the end of the dipper at the bucket pivot pin or cross pin on the bucket linkage.
- C. Lift the load with the backhoe so the load is 25 to 50 mm (one or two inches) above the ground.

- D. Swing the load all the way to one side.
- E. Move the load away from the machine. Make sure you keep the load 25 to 50 mm (one to two inches) above the ground.
- F. Lower the load to the ground if (1) one of the stabilizers is raised above the ground or (2) there is any indication that the stability of the machine is reduced.
7. Always move the load slowly. Do not move the load over the top of persons. Keep all persons away from the load.
8. When the load is raised, keep all persons away until the load is placed on blocks or is placed on the ground.

**IMPORTANT:** *Make sure that you use rigging equipment that has the capacity to lift the loads that you will be moving. Always check the rigging material each day for damage or missing parts.*

Shop Aftermarket Parts

## Backhoe Auxiliary Hydraulics

With the engine stopped, connect the hydraulic lines for the attachment to the male and female quick couplers located on the right-hand side of the boom.

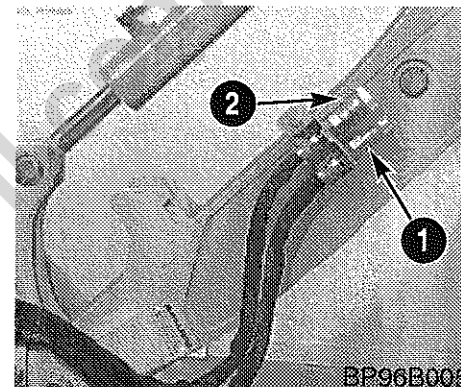

1. Male Quick Disconnect  
2. Female Quick Disconnect

The male coupler is the POWER connection for impacting equipment such as hammers, compactors, tampers, etc. The male coupler for backhoe hydraulics is powered when the auxiliary hydraulic direction control lever is pushed out of neutral and away from the operator.

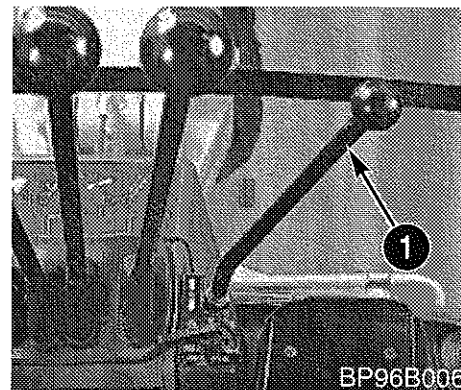

1. Auxiliary Hydraulic Control lever.  
Forward detent position.

Many attachments are intended to operate in only one direction. These attachments must always be installed to operate when the auxiliary hydraulic control lever is pushed away from the operator, powering the line to the male quick disconnect coupler.

**WARNING:** *Reverse connection could cause hazardous and unintended operation of, or damage to the attachment. Follow the attachment manufacturers instructions to avoid injury.*

M481

## Determining the Operating Mode

The operator must determine if low flow mode or high flow mode will be used. Refer to the operating instructions supplied with the attachment to determine the correct operating mode, and other instructions for safe operation. Some attachments can be damaged by a flow rate that is too high. Be sure you know and use the correct flow rate for the attachment. High or low flow mode will be determined by the position of the T-handle. See page 106.

**Low Flow Mode**

To operate in the low flow mode make sure the T-handle is in the neutral (middle) detent position.

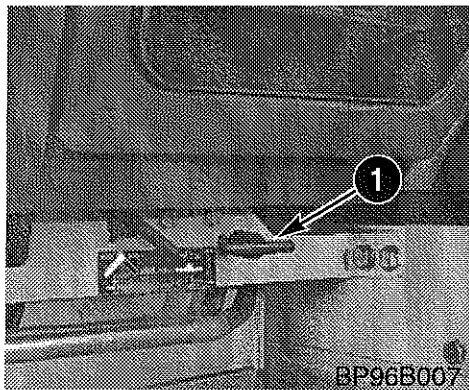

1. T-handle Neutral Position

Set the flow control knob on the backhoe control console to the approximate desired flow rate between 0 GPM and 20 GPM, using the numbers on the inner ring under the flow control knob.

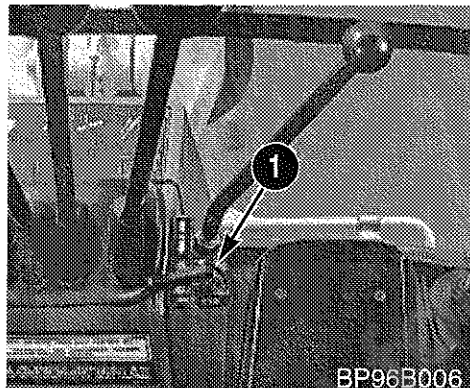

1. Flow Control Setting

**IMPORTANT:** To obtain the required flow rates, the engine must be at full throttle, approximately 2200 RPM.

**High Flow Mode**

To operate in the high flow mode make sure the T-handle is pushed into the IN (IN detent) position.

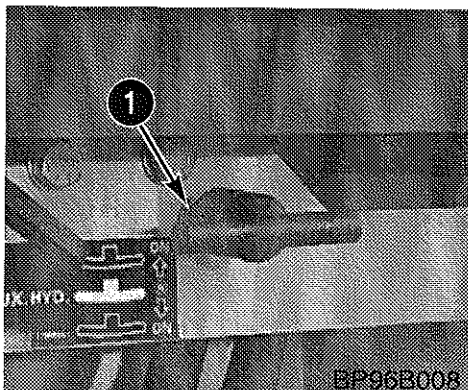

1. T-handle IN Detent

Set the flow control knob to the approximate flow rate between 25 GPM and 27 GPM, using the numbers on the outer ring under the flow control knob.

**IMPORTANT:** The flow control knob will have little effect on flow when in the high flow mode. Be sure your attachment will not be damaged by 25 to 27 GPM flow.

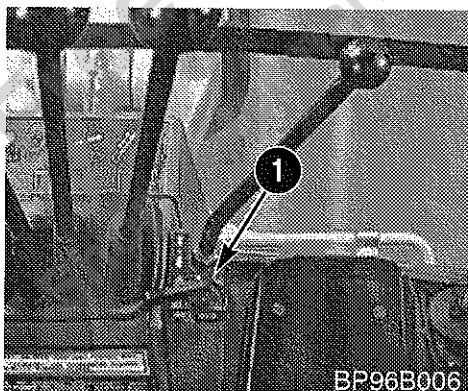

1. Flow Control Settings

**IMPORTANT:** To obtain the required flow rates, the engine must be at full throttle, approximately 2200 RPM.

**Using the Direction Control Lever to Actuate Auxiliary Hydraulic Attachments**

Be sure the T-handle and control knobs are set as required. Put the direction control lever in the neutral (middle) detent position.

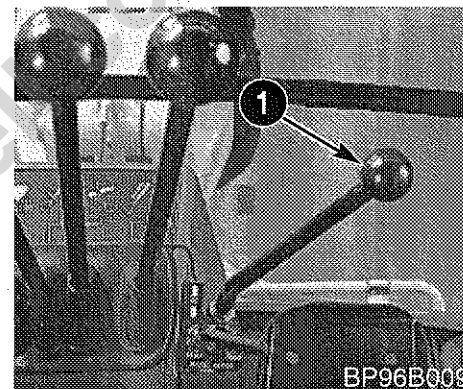

1. Control Lever in Neutral (middle) Detent

Push the rocker switch to the ON position. Now the attachment can be operated using the directional control lever.

**NOTE:** Many attachments are intended to operate in only one direction. These attachments must always be installed to operate when the auxiliary hydraulic control lever is pushed away from the operator, powering the line to the male quick disconnect coupler.

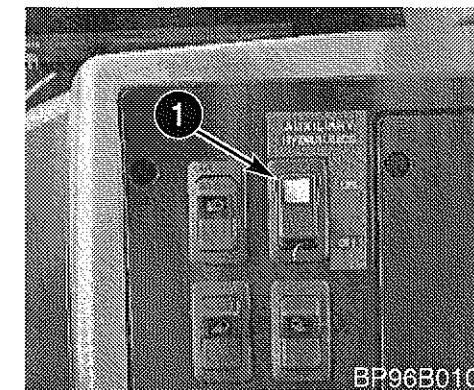

1. Rocker Switch ON

When the rocker switch is in the ON position the foot control will not work.

When the attachment is no longer needed, put the direction control lever in the neutral (middle) detent position and push the rocker switch to the OFF position.

## Using the Foot Control Switch to Actuate Auxiliary Hydraulic Attachments

Determine the desired flow mode and set the T-handle and flow control knob as required. See pages 105 and 106 to determine the operating mode.

Put the rocker switch in the OFF position and do not step on the foot control switch.

**IMPORTANT:** Many attachments are intended to operate in only one direction. These attachments must always be installed to operate when the auxiliary hydraulic control lever is pushed away from the operator, powering the line to the male quick disconnect coupler.

Put the direction control lever in the detent position away from the operator. Press and release the foot control switch as needed to start and stop the attachment.

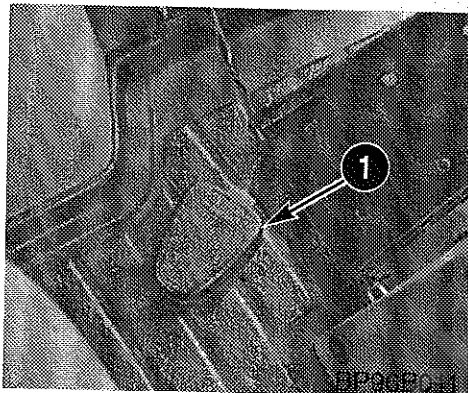

1. Foot Control Switch

Put the direction control lever in the neutral (middle) detent when the attachment is no longer needed.

## Hand Held Auxiliary Hydraulics

With the engine stopped, connect the attachment to the quick couplers located in front of the fuel tank.

**WARNING:** Reverse connection could cause hazardous and unintended operation of, or damage to the attachment. Follow the attachment manufacturers instructions to avoid injury. M481

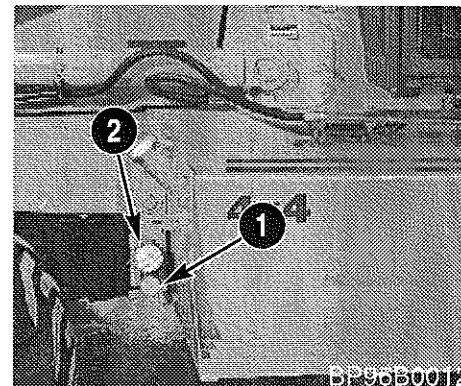

1. Male Coupler  
2. Female Coupler

Put the T-handle, which is above the fuel tank, in the IN position to pressurize the male coupler. Pull it out to pressurize the female coupler, if needed.

**IMPORTANT:** Many attachments are intended to operate in only one direction. Be sure the T-handle is positioned to pressurize the correct coupler.

The flow control knob for hand held hydraulics is located above the fuel tank and under the step, close to the T-handle. Set the flow rate control knob to the approximate flow rate required. Full clockwise rotation will give approximately 14 GPM. Full counterclockwise will give approximately 0 GPM.

Start the engine.

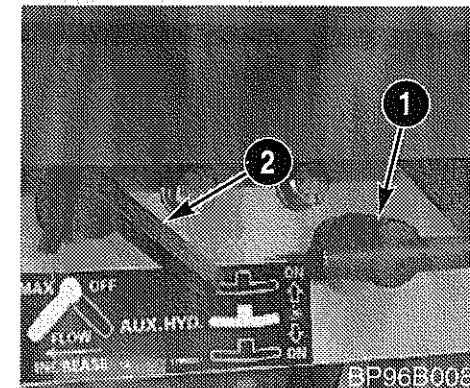

1. T-handle  
2. Flow Control Knob

## OPERATING INSTRUCTIONS

Put the rocker switch in the ON position to power the attachment.

**IMPORTANT:** To obtain the 14 GPM flow, the engine speed must be at least 1800 RPM.

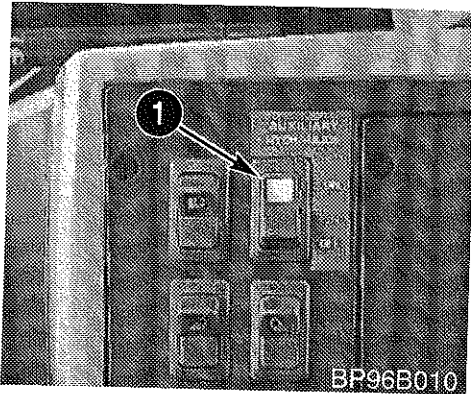

1. Rocker Switch ON

When the attachment is no longer needed, push the rocker switch to the OFF position and put the T-handle in the neutral (middle) detent.

## WHEELS/TIRES



**WARNING:** Exploding tires and/or rim parts can cause injury or death. Keep yourself and others out of the DANGER AREA. Stand on the tread side of the tire. Always use the correct air pressure and follow the instructions in this manual for adding air or servicing the tires.

SD020



**WARNING:** Do NOT weld to wheel or rim when a tire is installed. Welding will cause an explosive air/gas mixture that will be ignited with high temperatures. This can happen to tires inflated or deflated. Removing air or breaking bead is not adequate. Tire MUST be completely removed from the rim prior to welding.

SB134



**WARNING:** Explosive separation of the tire and/or rim parts can cause injury or death. When tire service is necessary, have a qualified tire mechanic service the tire.

84-113

Check the air pressure and the condition of the tires every 100 hours of operation. See page 112 for the correct tire air pressure.

1. Before you add air, have the tire correctly installed on the machine or put the tire in a restraining device (tire inflation cage).

### Tire or Rim Service/ Inflating the Tire

Always have a qualified tire mechanic service the tires and rims on this machine. It is recommended that you have this mechanic inflate the tires. To prevent accidents, always use a restraining device (tire inflation cage), correct equipment, and correct procedure. Explosive separation of the tire can cause serious injury.

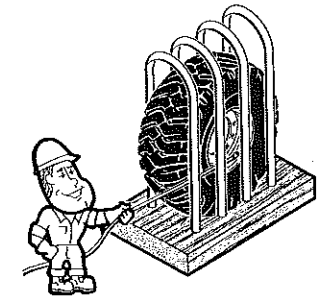

B790480T

### Adding Air to the Tires

This procedure is only for adding air to the tire. If the tire has lost all the air, or service to the tire or rim is required, do the following:

2. Use an air hose with remote shutoff valve and a self-locking air chuck.
3. Be sure to wear face protection. Stand behind the tread of the tire and make sure all persons are away from the side of the tire before you start to add air.
4. Inflate the tire to the recommended air pressure. DO NOT inflate the tire more than the recommended pressure given on page 112.

### Wheel Nut and Bolt Torques

When the machine is new or when a front wheel is removed for service, check the wheel nut or bolt torques every 10 hours of operation until the wheel nuts or bolts remain tight.

**NOTE:** The above procedure is for the front wheels only. Do not follow this procedure on the rear wheels.

### Front Wheel Mounting Bolts

Two wheel drive machines ..... 156 to 203 Nm (115 to 150 pound-feet)  
 Four wheel drive machine ..... 270 to 352 Nm (200 to 260 pound-feet)

### Rear Wheel Mounting Nuts

**IMPORTANT:** The rear wheel mounting nuts on this machine are metric. Use only the mounting nuts shown in the parts catalog for this machine.

Rear wheel mounting nuts ..... 129 to 136 Nm (95 to 100 pound-feet)  
 Then turn in the tightening direction an additional 55 to 65 degrees.)

### Tire Air Pressures - 580L and 580 Super L

#### Front Tires

Size	Ply rating	Type Tread	Air Pressure	
			kPa, bar	(psi)
11L x 16 (2WD)	10	F3	358, 3.6	(52)
12 x 16.5 (4WD)	8	Lug	345, 3.5	(50)

#### Rear Tires

Size	Ply rating	Type Tread	Air Pressure	
			kPa, bar	(psi)
17.5L x 24	10	R4	220, 2.2	(32)
19.5L x 24	10	R4	193, 1.9	(28)

### Tire Air Pressures - 590 Super L

#### Front Tires

Size	Ply rating	Type Tread	Air Pressure	
			kPa, bar	(psi)
14.5/75L x 16.1 (2WD)	10	F3	276, 2.8	(40)
14 x 17.5 (4WD)	10	Lug	380, 3.8	(55)

#### Rear Tires

Size	Ply rating	Type Tread	Air Pressure	
			kPa, bar	(psi)
21L x 24	10	R4	179, 1.8	(26)

### Procedure to Install the Tires

When the tire is installed on a wheel, make sure to have the tread of the tire in the direction shown in the following photograph.



BP9410118

**NOTE:** The front wheels can be turned around (tread direction reversed) if more traction is required in REVERSE.

This page left blank

## LUBRICATION / MAINTENANCE CHARTS

### GENERAL SAFETY BEFORE YOU SERVICE



**WARNING:** *Improper service or repair can cause injury or death. If you do not understand the service procedures for this machine, see your Case dealer or the Service Manual for this machine.*

SA021

Read the safety decals and information decals on the machine. Read the operator's manual and safety manual. Understand the operation of the machine before you start servicing.

Use the correct safety clothing and safety equipment. Understand how to use a fire extinguisher and first aid kit.

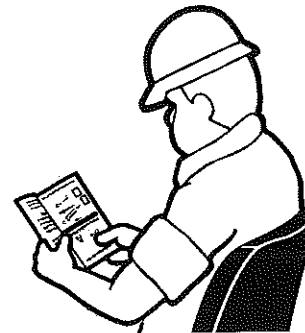

B801147T

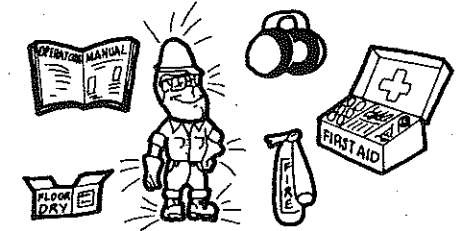

B770996R

Before you service the machine, put a Do Not Operate tag on the steering wheel. One Do Not Operate tag, is included with your new machine. Additional tags, part number 321-4614, are available from your Case dealer.

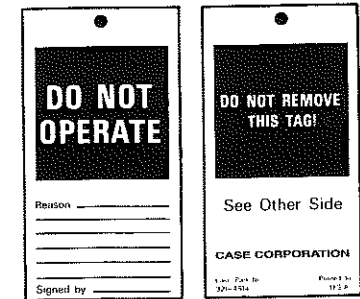

L950206Z

### ENGINE HOURMETER

Service your machine at the intervals and locations given in the Lubrication/Maintenance Charts. When you service your machine, use only high quality Case lubricants.

The engine hourmeter shows the amount of actual hours the engine has run. Use the engine hourmeter along with the Lubrication/Maintenance Charts to service your machine at the correct time periods.

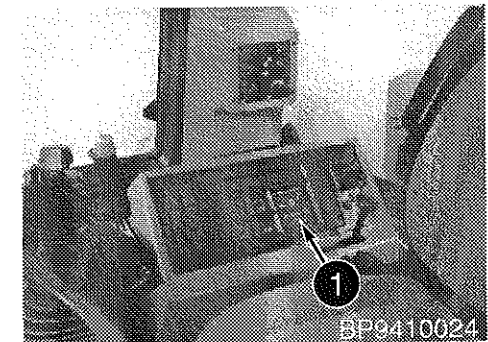

BP9410024

1. Hourmeter

## SUPPORT STRUT FOR LOADER LIFT ARMS

**WARNING:** If you service the machine with the loader lift arms raised, always use the support strut.

1. Empty the loader bucket, raise the loader lift arms to maximum height and stop the engine.

2. Remove the rear pin from the support strut and lower the support strut onto the cylinder rod.

3. Install the rear pin in the support strut.

4. Slowly lower the lift arms onto the support strut.

If you do not follow this procedure, you can cause serious injury or death if the loader lift arms are lowered by accident.

SA068

### Supporting Loader Lift Arms

1. Raise the loader lift arms to maximum height and stop the engine.

2. Remove the rear pin, and lower the support strut onto the cylinder rod.



3. Install the rear pin. Slowly lower the lift arms onto the support strut.



### Lowering Loader Lift Arms

1. Raise the loader lift arms and remove the pin from the support strut.

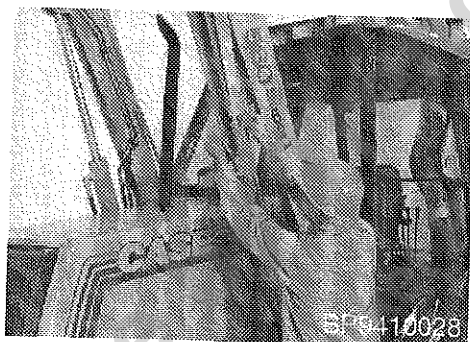

2. Raise the support strut up to the storage position and install the pin.



3. Lower the loader to the ground.

## FLUIDS AND LUBRICANTS

### ENGINE CRANKCASE

Capacity with filter change ..... 11 litres (11.6 U.S. quarts)

Specifications ..... See page 135

### FUEL TANK

Capacity (standard machine) ..... 119 litres (31.4 U.S. gallons)

Specifications ..... See page 146

### COOLING SYSTEM

Capacity with heater ..... 16.5 litres (17.4 U.S. quarts)

Capacity without heater ..... 15.8 litres (16.7 U.S. quarts)

Specifications ..... 50% water and 50% ethylene glycol

### HYDRAULIC RESERVOIR REFILL

Capacity with filter change ..... 54.5 litres (14.4 U.S. gallons)

Capacity without filter change ..... 52.6 litres (13.9 U.S. gallons)

Specifications ..... Case TCH fluid

### TRANSMISSION

#### 2 Wheel Drive

Total system capacity ..... 18.5 litres (19.5 U.S. quarts)

Refill capacity with or without filter change ..... 16 litres (16.9 U.S. quarts)

#### 4 Wheel Drive

Total system capacity ..... 21 litres (22 U.S. quarts)

Refill capacity with or without filter change ..... 18.5 litres (19.5 U.S. quarts)

### FRONT DRIVE AXLE - 4 WHEEL DRIVE

#### 580L and 580 Super L

Capacity - center bowl ..... 5.5 litres (5.8 U.S. quarts)

Capacity - each wheel end ..... 0.7 litres (0.75 U.S. quarts)

#### 590 Super L

Capacity - center bowl ..... 6.5 litres (6.9 U.S. quarts)

Capacity - each wheel end ..... 1.0 litres (1.05 U.S. quarts)

### REAR AXLE

#### 580L and 580 Super L

Capacity - center bowl ..... 14.2 litres (15 U.S. quarts)

Capacity - each wheel end ..... 1.5 litres (1.6 U.S. quarts)

#### 590 Super L

Capacity - center bowl ..... 14.2 litres (15 U.S. quarts)

Capacity - each wheel end ..... 2.0 litres (2.1 U.S. quarts)

### BRAKE MASTER CYLINDER

(Brake fluid supplied by hydraulic reservoir.)

## LUBRICATION/MAINTENANCE CHART

PAGE NO.	SERVICE POINTS	NO. OF POINTS	FREQUENCY IN HOURS						
			CLEAN	CHANGE	CHECK	GREASE	DRAIN	REPLACE	
139	Air Filter Pre-Cleaner	1	AR						
140	Air Filter (See Note 1)	1			AR				
151	Hydraulic Filter (See Note 2)	1			AR				
165	Fan Belt Condition	1			AR				
168	Air Conditioning Drive Belt Condition (If Equipped)	1			10				
136	Engine Oil Level (See Note 3)	1			10				
122	Loader Pivot Points	16-24				10			
124	Backhoe Pivot Points	36				10			
128	Front Axle Pivot Points 2 Wheel Drive	10				10			
144	Coolant Reservoir Fluid Level	1			10				
129	Front Axle Pivot Points 4 Wheel Drive	6				10			
127	Extendahoe Dipper Slides	2				50			
123	4 in 1 Bucket Pivot Points	8				50			
147	Main Fuel Filter (Drain Water)	1					50		
144	Radiator Coolant Level				50				
150	Hydraulic Reservoir Fluid Level	1			50				
130	4 Wheel Drive Shaft	3				50			
131	Rear Axle Drive Shaft	3				50			
127	Backhoe Pedal Pivots	1-2				100			
112	Tire Pressure and Condition	4			100				
166	Spark Arresting Muffler (If Equipped)	1	100						
132	Seat Post	1				250			
176	Battery(ies)	1	250						
168	Air Conditioning Drive Belt Tension (If Equipped)	1			250				
153	Transmission Fluid Level	1				250			
137	Engine Oil	1			250				
137	Engine Oil Filter	1							250
159	Front Axle Oil Level and Breather (4WD)	1	250		250				
157	Rear Axle Oil Level and Breather	2	250		250				
SM	Cab Air Conditioning (If Equipped)				250				

AR = As Required

## LUBRICATION/MAINTENANCE CHART

PAGE NO.	SERVICE POINTS	NO. OF POINTS	FREQUENCY IN HOURS					
			CLEAN	CHANGE	CHECK	GREASE	DRAIN	REPLACE
147	Fuel Tank (Drain Water and Sediment)	1					250	
74	Differential Lock Pedal	1				500		
169	ROPS Cab or, ROPS Canopy				500			
132	Seat Mounting Post (See Note 5)				500			
132	Seat Slide Rails (See Note 6)				500			
147	Fuel Filters (In-Line and Main Filter)	2						500
SM	Front Axle Bearings (2 Wheel Drive)					500		
SM	Front Axle Seals (2 Wheel Drive)							500
151	Hydraulic Filter (See Note 4)	1						1000
152	Hydraulic Fluid (See Note 4)	1		1000				
176	Battery Fluid Level				1000			
160	Cab Air Filters (If Equipped)	2	1000		1000			
154	Rear Axle Oil			1000				
154	Transmission Fluid and Filter			1000				1000
159	Front Axle Oil (4 Wheel Drive)			1000				
SM	Engine Valve Clearances				1000			
140	Air Filter Elements							1000
145	Engine Cooling System		1000					
145	Engine Coolant (See Note 7)			2000				

**NOTE 1:** Service the air filter elements if the air filter warning lamp illuminates.**NOTE 2:** Replace the hydraulic filter if the hydraulic filter warning lamp illuminates.**NOTE 3:** Every 10 hours of operation or once each day, whichever comes first.**NOTE 4:** Every 1000 hours of operation or one time each year, whichever comes first.**NOTE 5:** Lubricate the suspension seat post with light oil (if equipped).**NOTE 6:** Every 500 hours of operation or one time each six months, whichever comes first.**NOTE 7:** Every 2000 hours of operation or one time every two years, whichever comes first.

## SYSTEMGARD LUBRICATION ANALYSIS PROGRAM

Ask your Case dealer about our lubricant analysis program, Systemgard. Through this service, your lubricants are tested in an independent laboratory. You simply remove a sample of lubricant from your machine and send the sample to the Systemgard laboratory. After the sample is processed, the laboratory will report back to you and guide you with maintenance requirements. Systemgard can help support your equipment up time and provide you with a service that can pay back dividends when you trade for another piece of Case equipment.

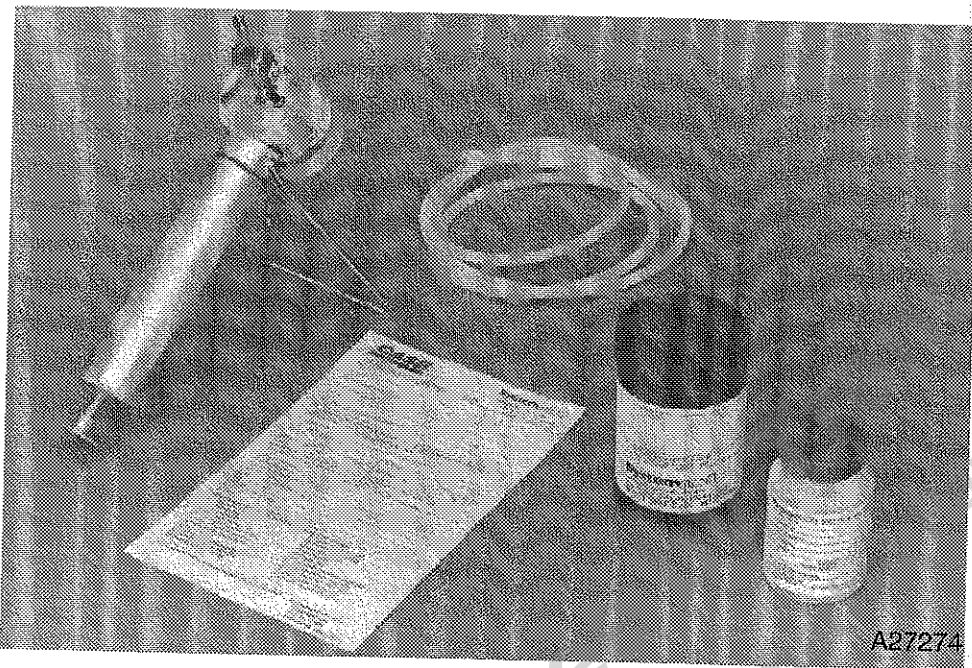

A27274

## ENVIRONMENT

Before you service this machine and before you dispose of the old fluids and lubricants, always remember the environment. Do not put oil or fluids into the ground or into containers that can leak.

Check with your local environmental or recycling center or your Case dealer for correct disposal information.

## LUBRICATION/FILTERS/FLUIDS OPENING THE ENGINE HOOD

### To Open

1. Turn handle counterclockwise to release.

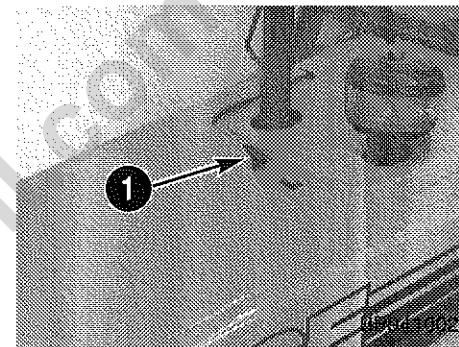

1. Handle

2. Lift hood and rotate forward.

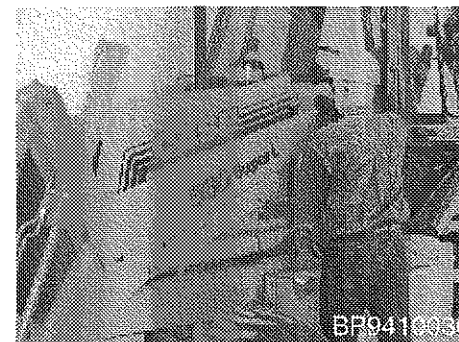

BP9410030



BP9410031

### To Close

1. Lower the hood and turn the handle clockwise to lock.

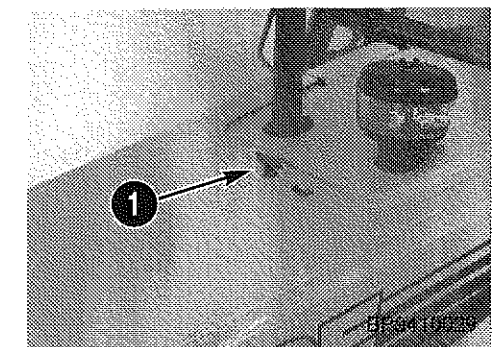

**IMPORTANT:** To avoid damage to the hood parts, always close the hood before moving the loader.

### LOADER GREASE FITTINGS

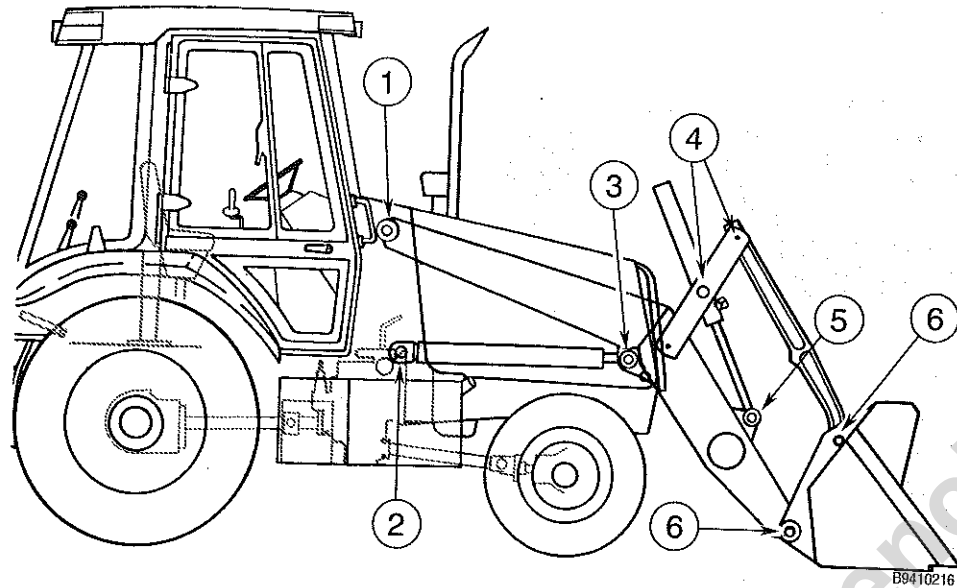

Use Case Molydisulfide Grease

Lubricate the loader pivot points every 10 hours of operation or each day. If you operate in severe conditions, lubricate more often. Clean the fittings before lubricating.

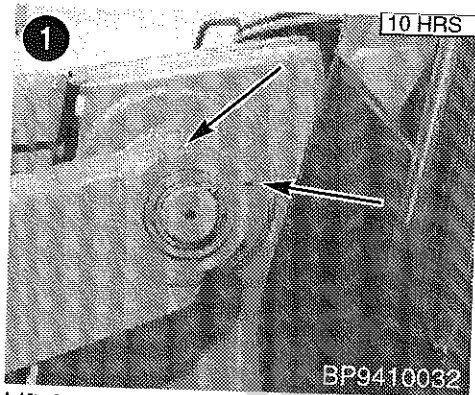

Lift Arm Pivot ..... 4

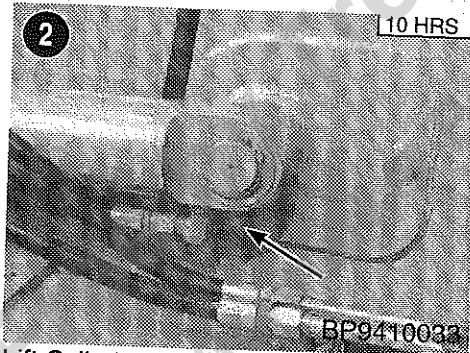

Lift Cylinder Closed End ..... 2

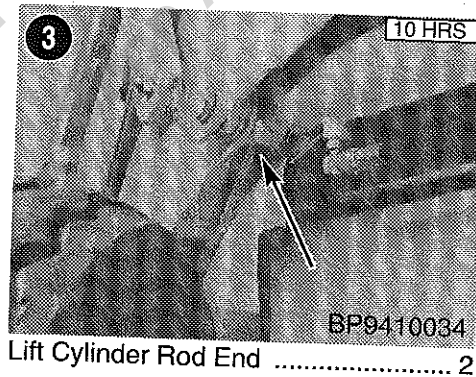

Lift Cylinder Rod End ..... 2

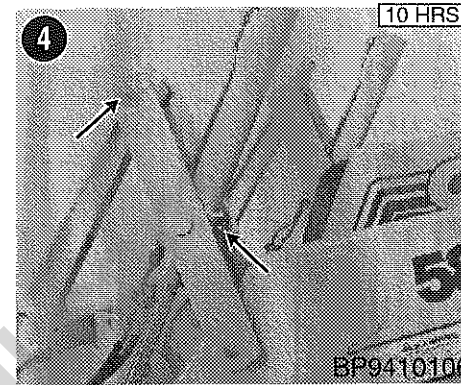

Bucket Link ..... 2  
Bucket Cylinder Trunnion ..... 2

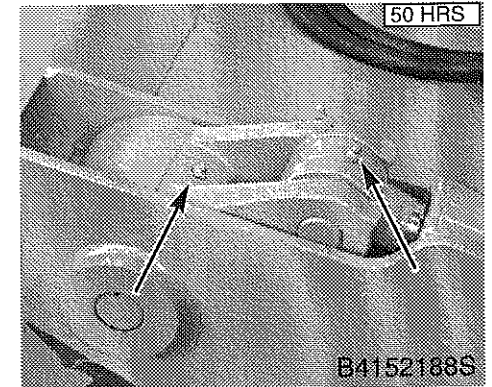

4-in-1 Bucket - Clam  
Cylinder and Clam Pivot ..... 4

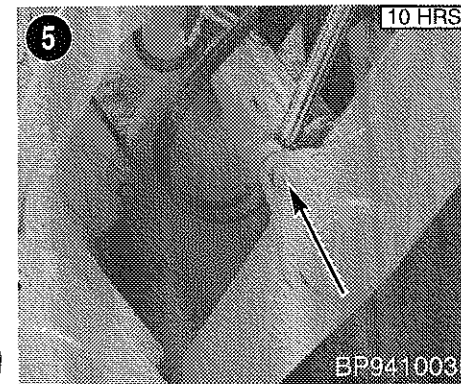

Bucket Cylinder Rod End ..... 2

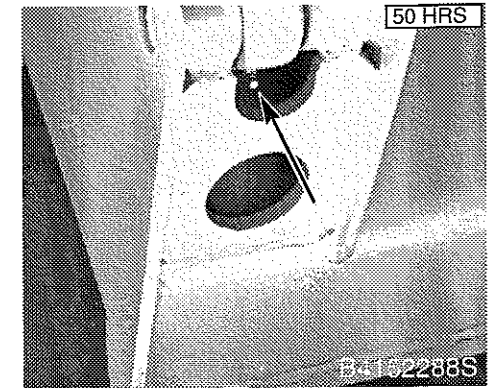

4-in-1 Bucket - Clam  
Cylinder Closed End ..... 2

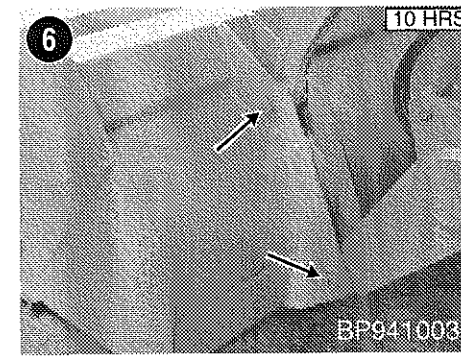

Bucket Pivots ..... 4

# BACKHOE GREASE FITTINGS

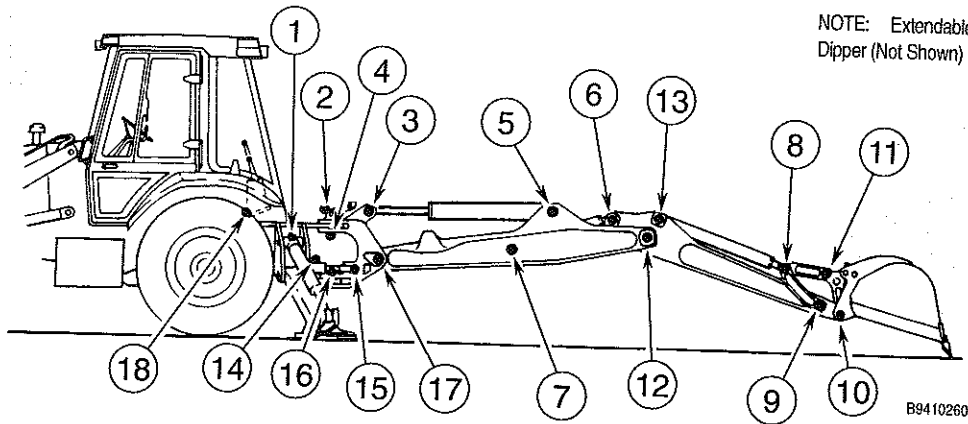

NOTE: Extendable Dipper (Not Shown)

B9410260

Use Case Molydisulfide Grease

Lubricate the backhoe pivot points every 10 hours of operation or each day. If you operate in severe conditions, lubricate more often. Clean the fittings before lubricating.

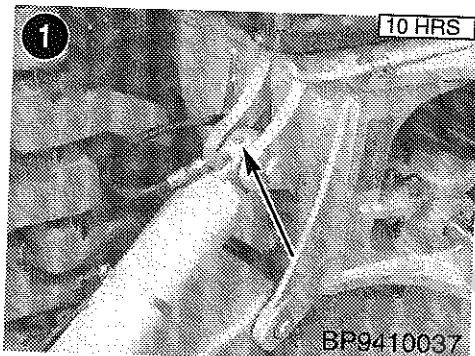

Stabilizer Cylinder Closed End ..... 2

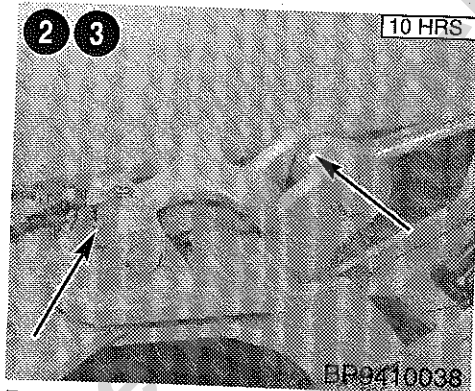

Boom Release ..... 1  
Boom Cylinder - Rod End ..... 1

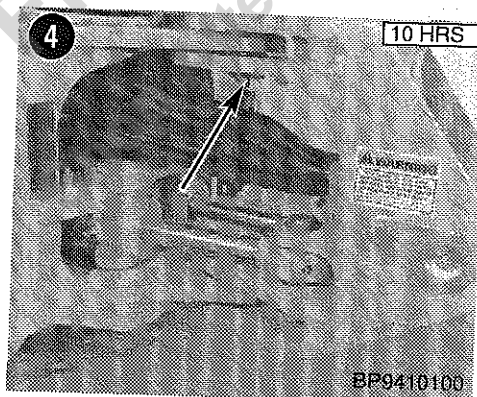

Upper Swing Pivot ..... 1

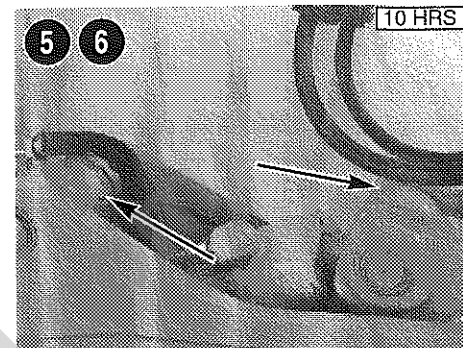

Boom Cylinder Closed End ..... 1  
Dipper Cylinder Rod End ..... 1

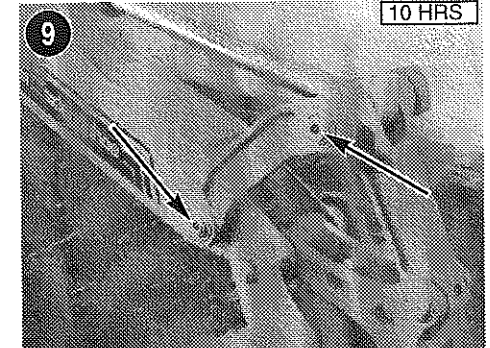

Bucket Links ..... 4

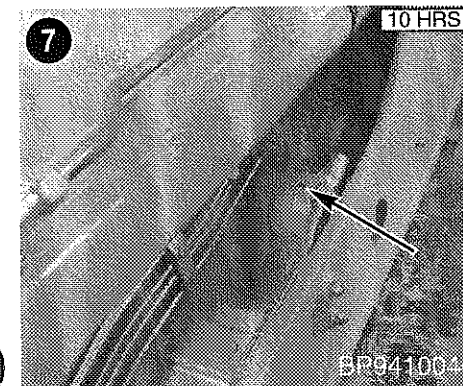

Dipper Cylinder Closed End ..... 1

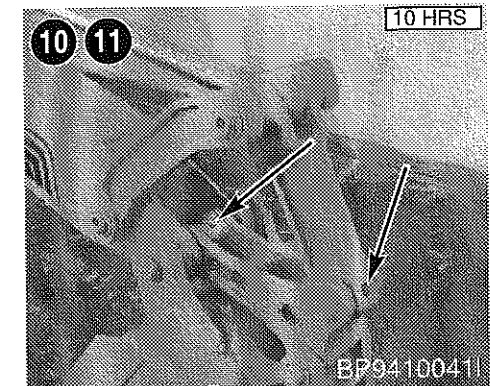

Bucket Link ..... 1  
Bucket Pivot ..... 1

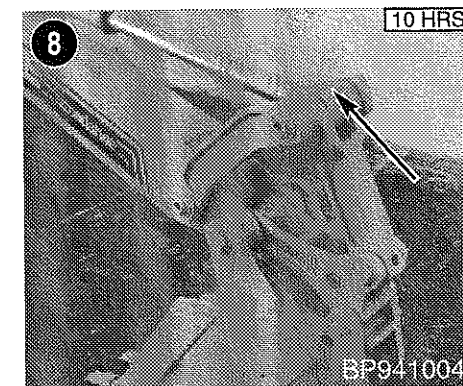

Bucket Cylinder Rod End ..... 1

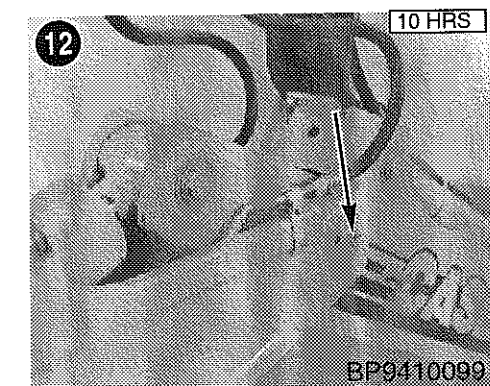

Dipper Pivot ..... 2

### BACKHOE GREASE FITTINGS

NOTE: Extendable Dipper (Not Shown)

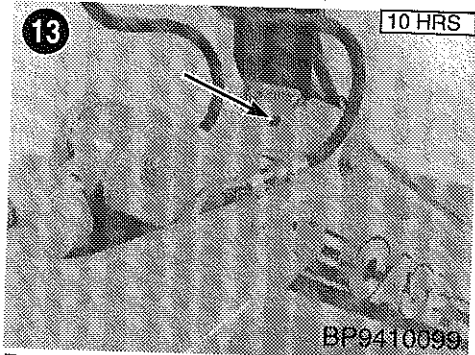
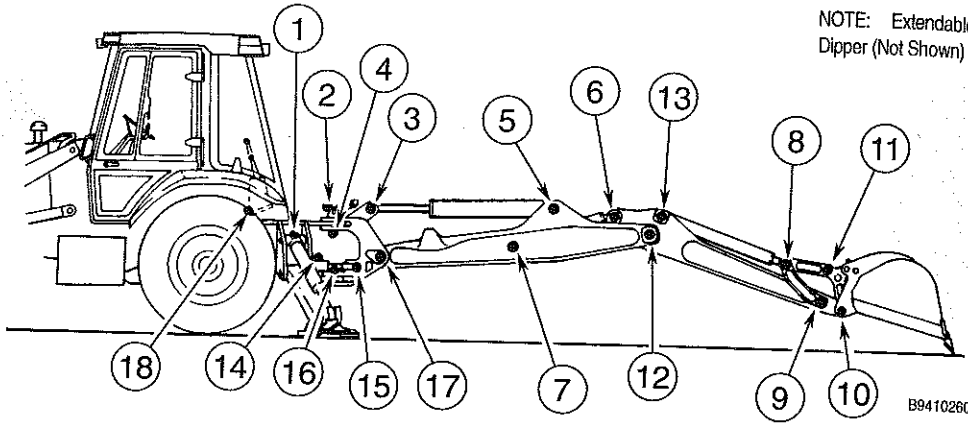

Bucket Cylinder Closed End ..... 1

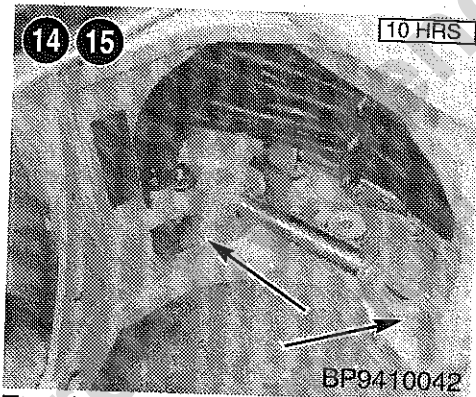

Trunnion ..... 4  
Swing Cylinder Rod End ..... 2

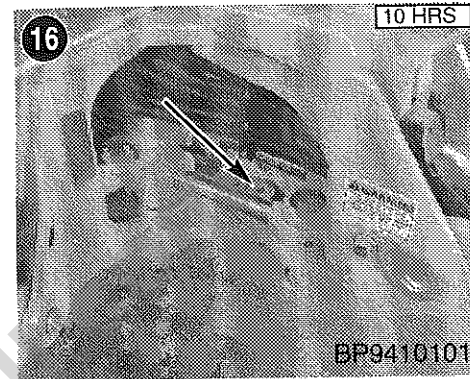

Lower Swing Pivot ..... 1

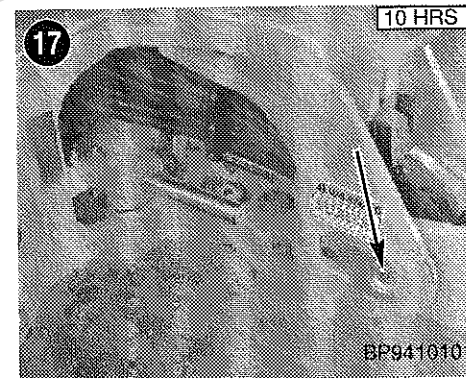

Boom Pivot ..... 2

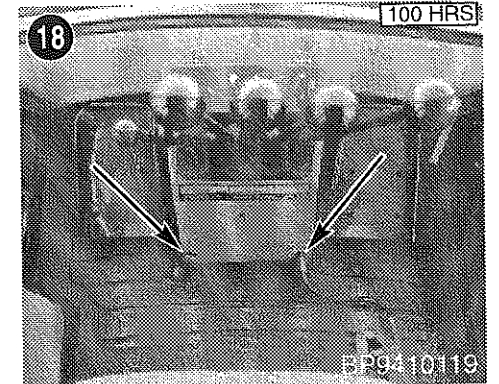

Foot Swing Pedals (If Equipped) ..... 2

Remove grease plugs (if equipped) when lubricating pedals. Install and tighten plugs when lubrication is complete.

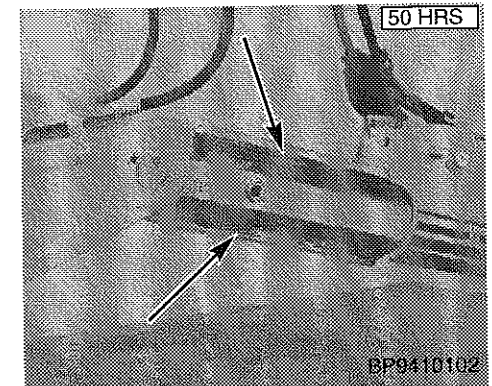

Extendable Dipper - Extend Dipper and Coat Slide on all Four Sides With Grease

#### Optional Bucket Links - with Coupler Removed

- Bucket Links at Cylinder Rod ..... 2
- Bucket Links at Bucket ..... 2

### MACHINE GREASE FITTINGS

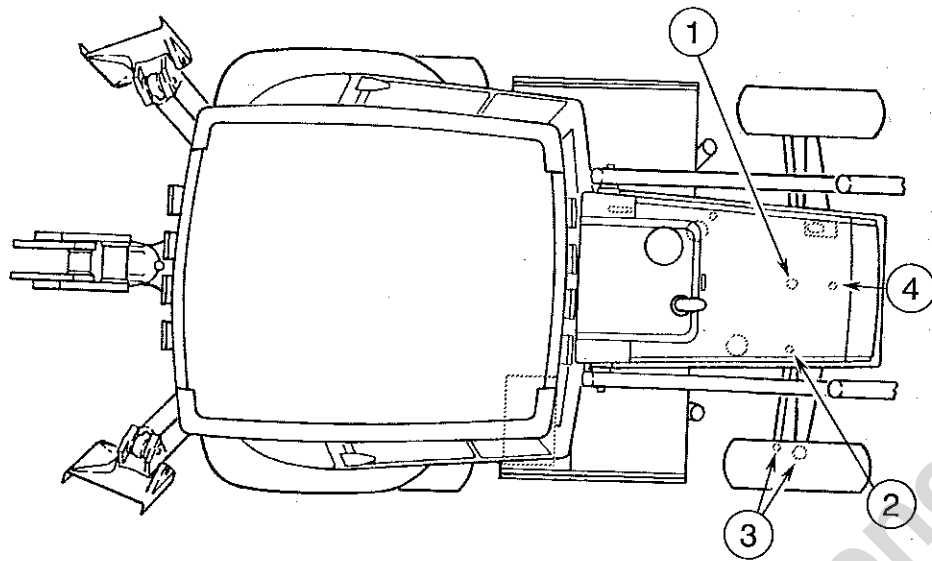

B9410217

Use Case Molydisulfide Grease

Lubricate the axle pivot points every 10 hours of operation or each day. If you operate in severe conditions, lubricate more often. Clean the fittings before lubricating.

#### Two Wheel Drive Front Axle

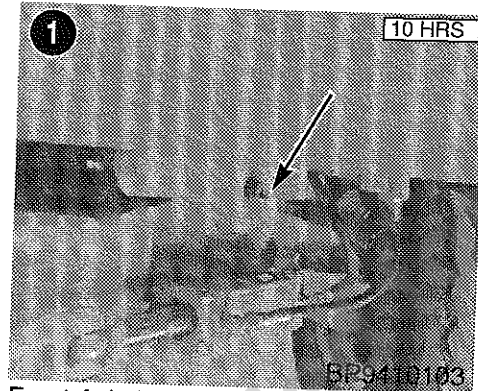

Front Axle Rear Pivot ..... 1

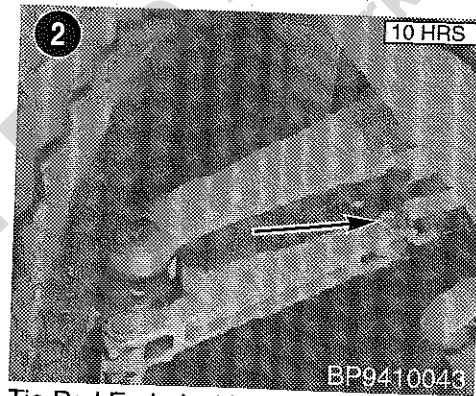

Tie Rod End - Inside ..... 2

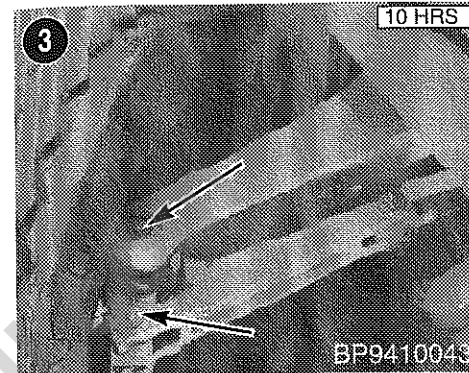

Tie Rod End - Outer ..... 2  
King Pins - Upper and Lower ..... 4

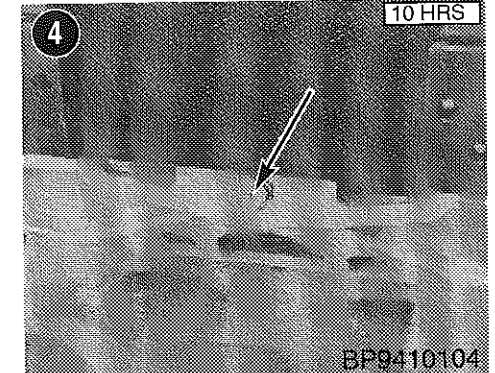

Front Axle Front Pivot ..... 1

#### Four Wheel Drive Front Axle

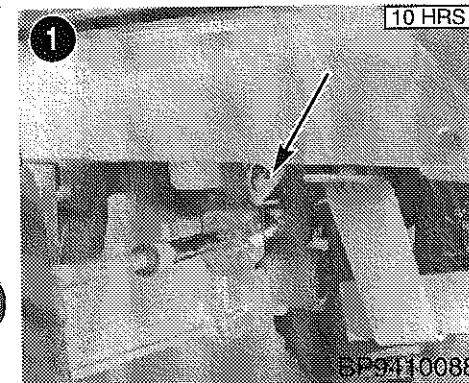

Front Axle Rear Pivot ..... 1

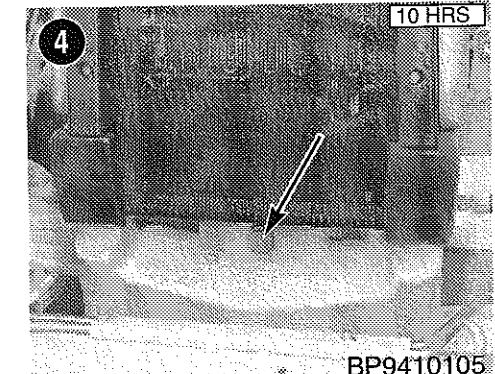

Front Axle Pivot ..... 1

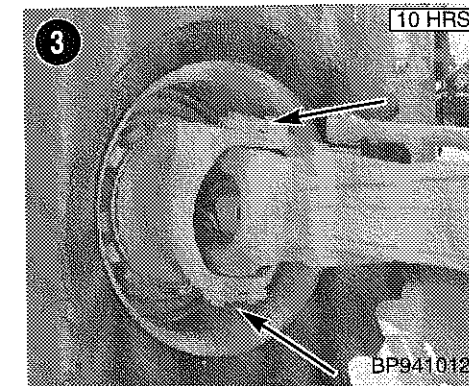

King Pins - Upper and Lower ..... 4

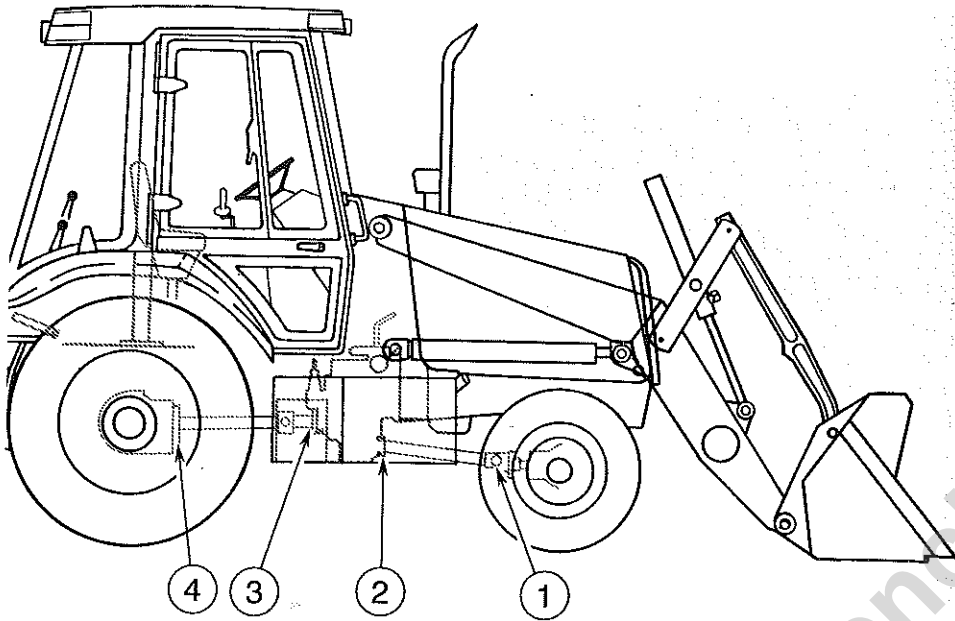

B9410216

Use Case Molydisulfide Grease

Lubricate the driveshaft pivot points every 50 hours of operation or each week. If you operate in severe conditions, lubricate more often. Clean the fittings before lubricating.

### Drive Shaft - Front 4 Wheel Drive Axle

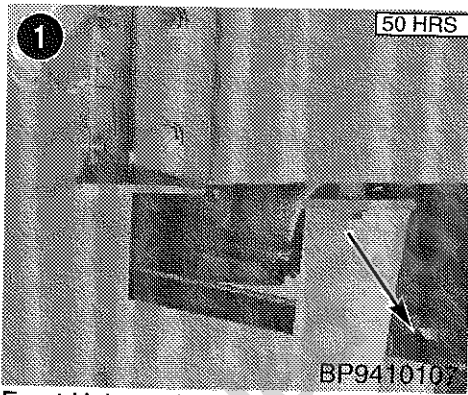

Front Universal Joint and Slip Spline ..... 1

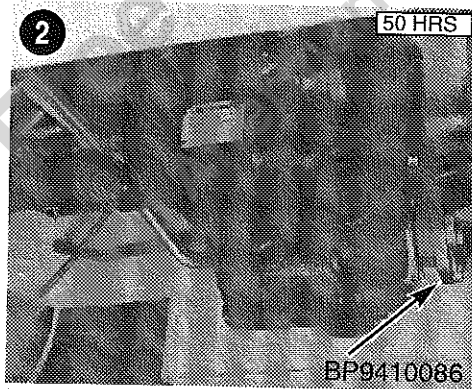

Rear Universal Joint ..... 1

### Drive Shaft - Transmission to Rear Axle

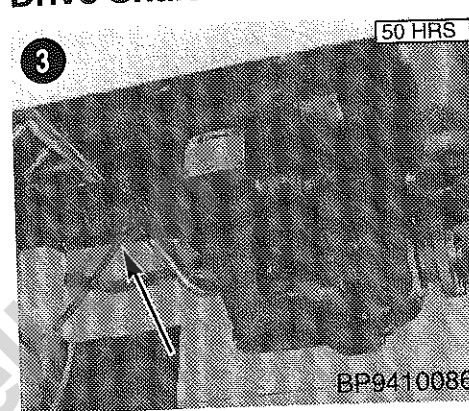

Front Universal Joint ..... 1

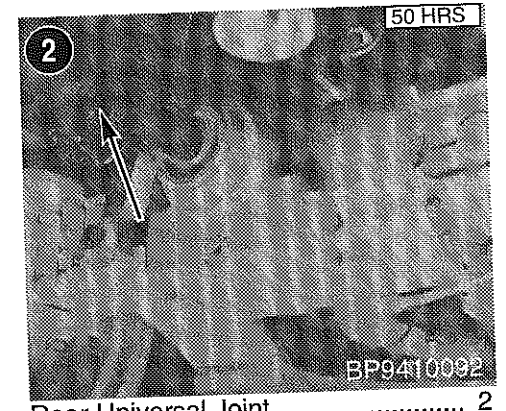

Rear Universal Joint ..... 2

### Differential Lock Pedal Pivot

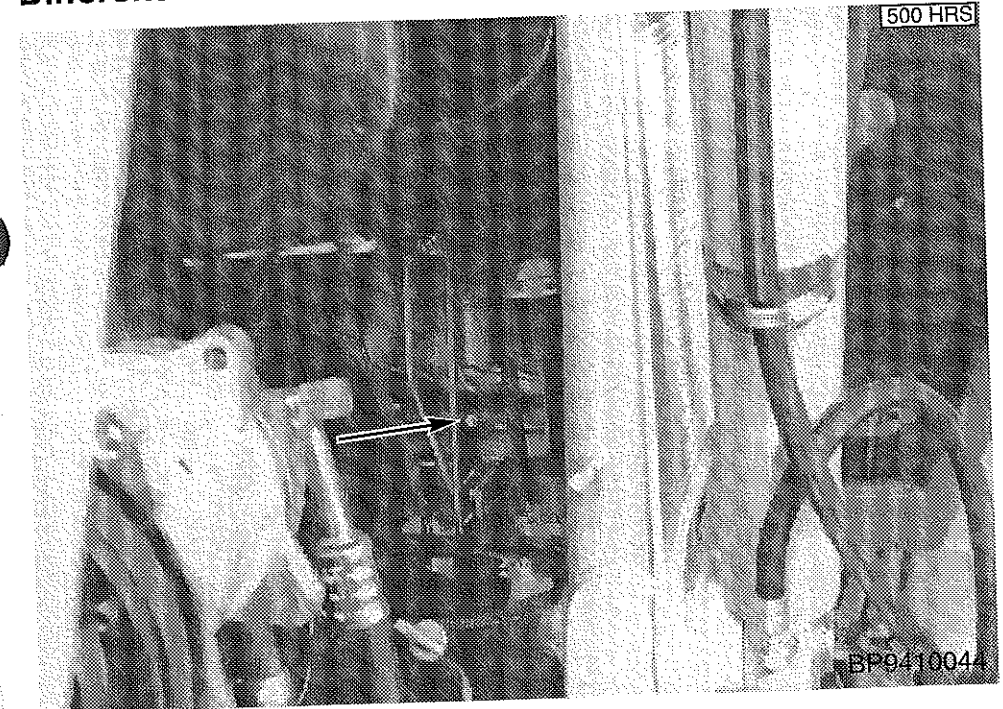

BP9410044

### Seat Post Grease Fitting

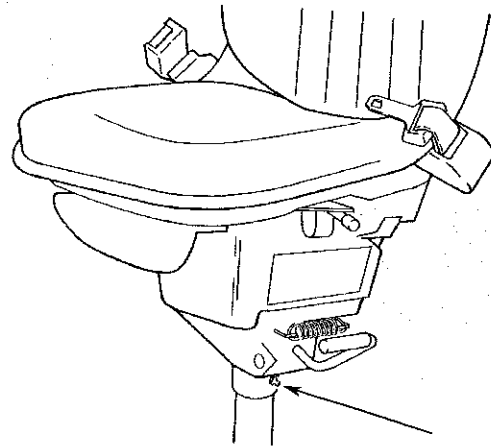

250 HRS

B9410144

**NOTE:** The suspension seat has no grease fitting. Lubricate the suspension seat through the hole in the seat post with light oil. Spray the lubricant in an upward direction.

### Suspension Seat Rails

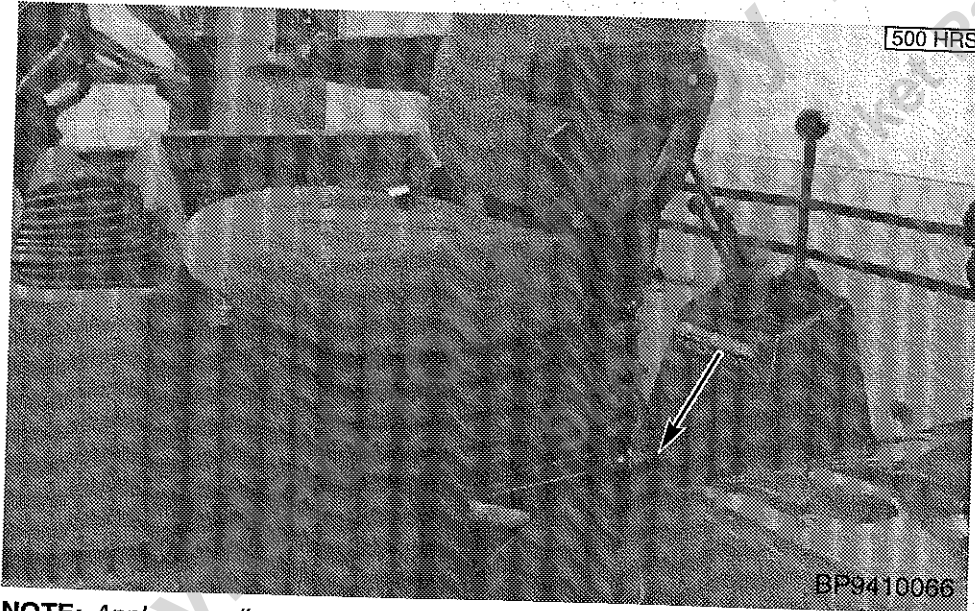

BP9410066

**NOTE:** Apply a small amount of grease to the last 76 mm (3 inches) of rail on each side. Move the seat forward and rearward, as required, to lubricate the rails.

### FLUID LEVELS

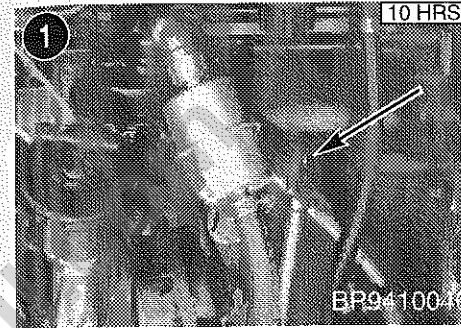

ENGINE OIL  
CASE NO. 1 ENGINE OIL

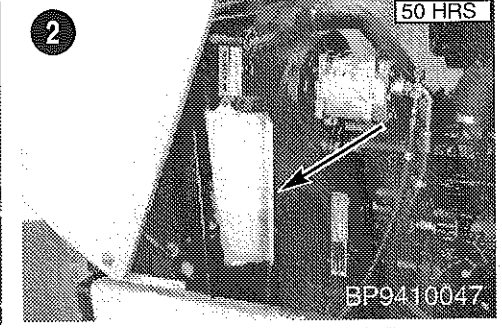

COOLANT RESERVOIR  
ETHYLENE GLYCOL AND WATER

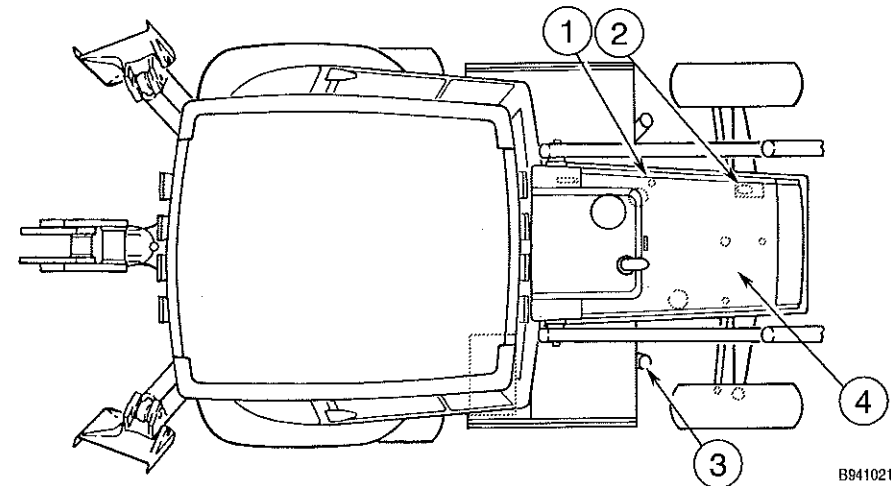

B9410217

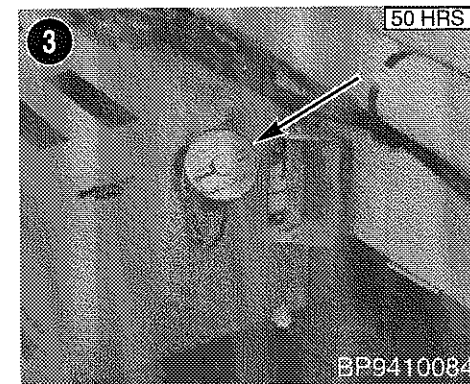

HYDRAULIC RESERVOIR  
CASE TCH FLUID



FRONT AXLE OIL LEVEL - 4 WD  
SEE PAGE 156 FOR PLANETARIES

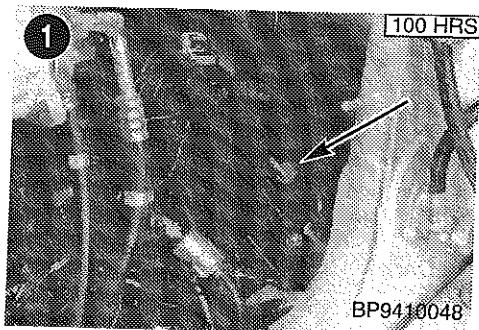

TRANSMISSION FLUID  
CASE HY-TRAN PLUS®

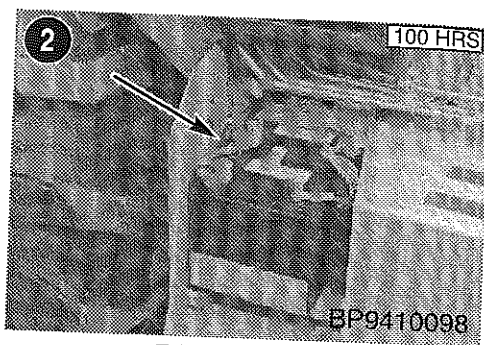

BATTERY(IES)  
DRINKING OR DISTILLED WATER

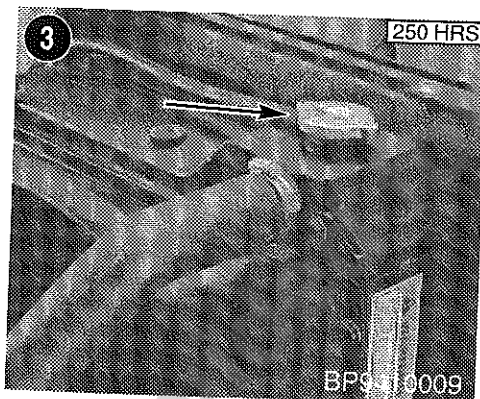
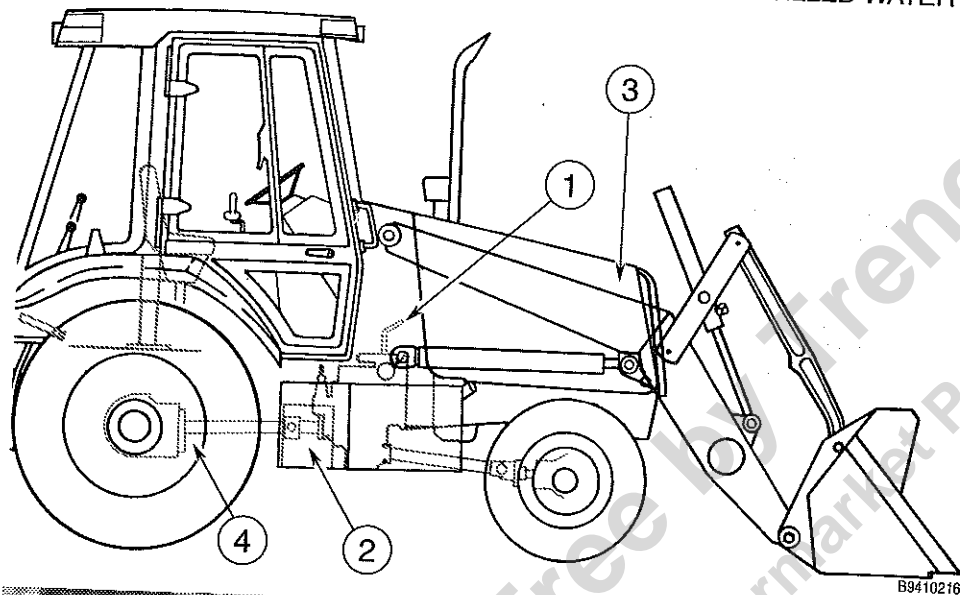

RADIATOR  
ETHYLENE GLYCOL AND WATER

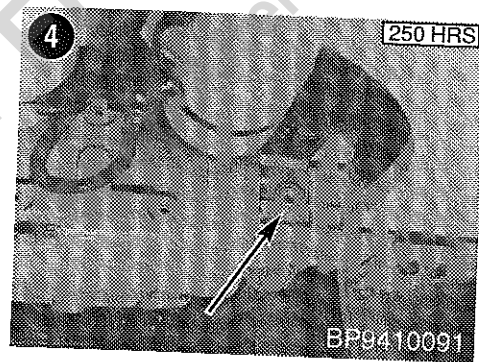

REAR AXLE OIL LEVEL  
SEE PAGE 155 FOR PLANETARIES

## ENGINE OIL RECOMMENDATIONS

Case No.1 Engine Oil is recommended for use in your Case Engine. Case Engine Oil will lubricate your engine correctly under all operating conditions. If Case No. 1 Multi-Viscosity Engine Oil is not available, Case Single Grade Engine Oil can be used.

If Case No.1 Multi-Viscosity or Single Grade Engine Oil is not available, use only oil meeting API engine oil service category CE.

See the chart below for recommended viscosity at ambient air temperature ranges.

**NOTE:** Do not put Performance Additives or other oil additive products in the engine crankcase. The oil intervals given in this manual are according to tests with Case lubricants.



654L9

## AMBIENT AIR TEMPERATURE RANGES

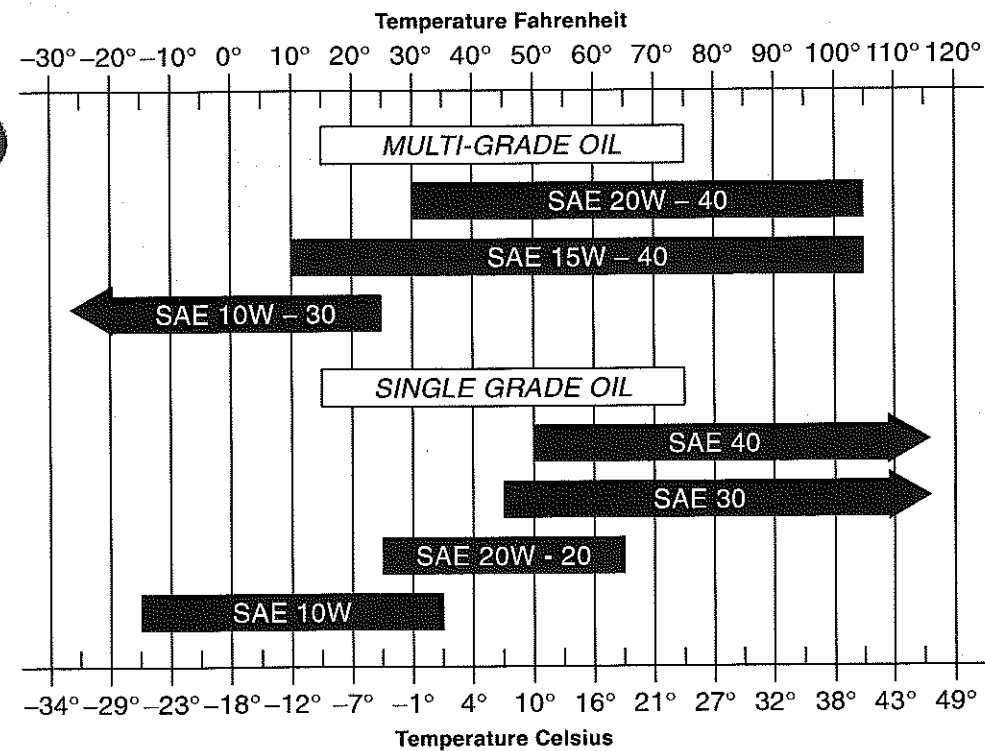

## ENGINE SERVICE SPECIFICATIONS

Oil Capacity - with filter change..... 11 litres (11.6 U.S. Quarts)  
 Oil Type..... See page 135

### Interval

Oil Level Check ..... Every 10 hours of operation or once each day  
 Oil Change and Filter Replacement ..... Every 250 hours of operation

## Engine Oil Level

Check the engine oil level before you start the engine each day or before the start of each 10 hour shift. Always check the oil level with the engine stopped and when the machine is on level ground. Push the engine oil level dipstick completely down and pull out to check the oil level.

If the oil level is below the ADD mark, add oil to raise the oil level up to the FULL mark.

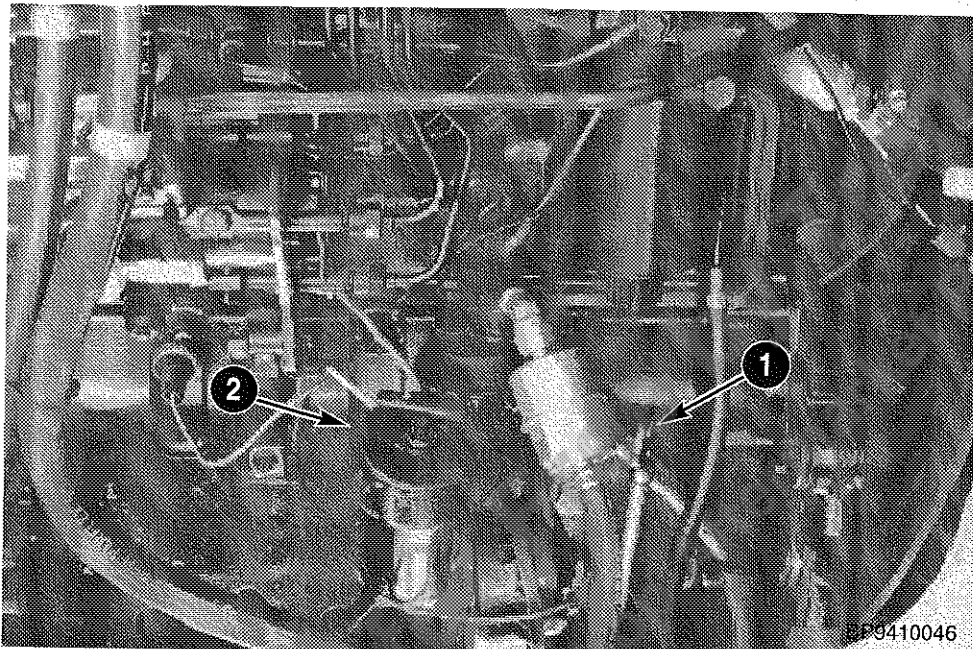

1. Engine Oil Level Dipstick

2. Engine Oil Fill Cap

## Oil Change and Filter Replacement

Change the engine oil and replace the filter after every 250 hours of operation or once a year, whichever occurs first.

**NOTE:** For more complete removal of foreign material, change the engine oil while the engine is still warm from operation.

**IMPORTANT:** You must shorten the oil change interval if you use diesel fuel with a sulphur content of more than 0.5%.

**IMPORTANT:** Change the engine oil more frequently when the engine operating conditions are severe (frequent stopping and starting and high or low engine temperatures).

1. Before draining the oil, have a container that will hold 11.3 litres (3 U.S. gallons).
2. Remove the engine oil drain plug.

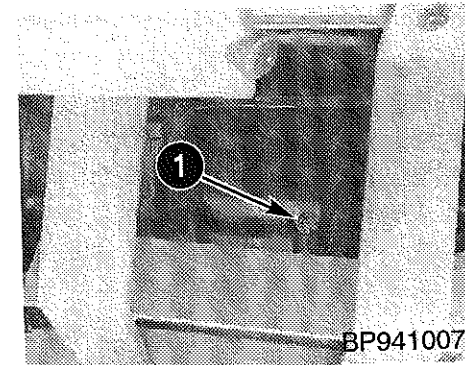

1. Engine Oil Drain Plug

3. Open the hood.

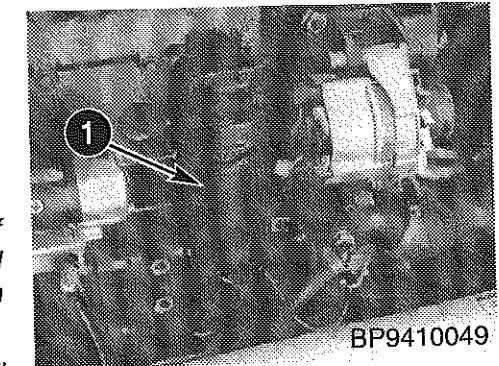

1. Engine Oil Filter

4. Turn the oil filter counterclockwise to remove. Discard the old filter.
5. Use a clean cloth and wipe the sealing surface of the oil filter base to remove all dirt.
6. Apply a thin layer of clean grease or oil to the gasket of the new oil filter.
7. Turn the new oil filter onto the base until the gasket makes contact with the base. Continue to tighten the filter for 3/4 turn with your hand.

**IMPORTANT:** Do not use a filter wrench to install the oil filter. An oil filter wrench can cause a leak if the filter is dented.

8. Install the drain plug.
9. Put new oil into the engine.

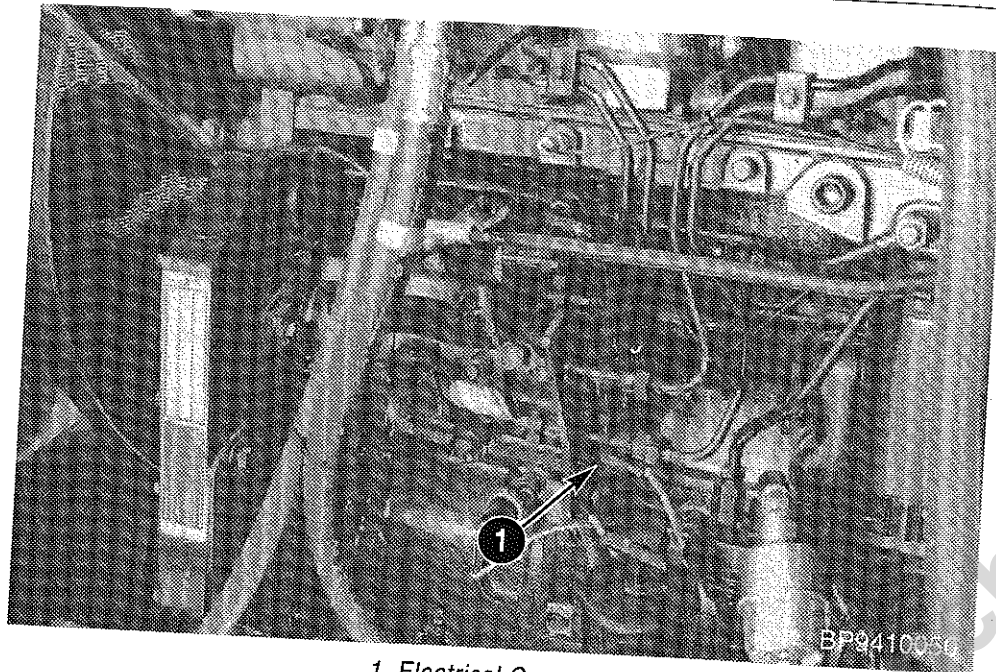

1. Electrical Connector

10. If your machine is equipped with a turbocharger, fill the turbocharger oil lines with oil.

A. See the photo at the top of this page. Disconnect the electrical connector to the injection pump solenoid. This will prevent the engine from starting.

B. Make sure other persons are clear of the machine. Turn the key switch to START and actuate the starter for about 10 to 15 seconds.

C. Connect the wire to the injection pump solenoid.

11. Start the engine and run at idle speed. Check the engine oil filter for leaks. After two minutes, stop the engine, wait 2 or 3 minutes, and check the engine oil level with the dipstick.

12. Close the hood.

### Systemgard Lubrication Analysis Program

The normal engine oil change interval is every 250 hours of operation, or once a year, whichever occurs first. Operating conditions, quality of the engine oil and sulphur content of the fuel can change this interval. It is recommended that you use the Systemgard Lubrications Analysis Program. See page 120 and your dealer.

## AIR FILTER SYSTEM

### Service Specifications

Air Filter Pre-Cleaner Service Interval..... As required  
 Air Filter Element Service Interval      Service the elements if the warning lamp for air filter restriction illuminates or every 1000 hours or once each year, whichever occurs first.

- The shelf life of a new air filter element is five years; do not install a new element that is more than five years old. The date of manufacture is on the end cap of the element.
- Replace both filter elements after one year in the machine.
- Do not remove the elements from the machine to check for restriction; always follow the recommended service instructions in this section.
- Each time you service the air filter system, make sure all hose connections and flanges are air tight. Replace all damaged parts.

2. Remove the bowl and clean with a damp cloth. Install the bowl and cap.

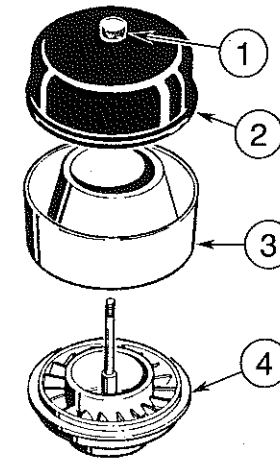

B861755.J

1. Nut                      3. Bowl  
 2. Cap                     4. Base

### Precleaner

Check the precleaner bowl and remove the dust as required.

1. Loosen the nut and remove the cap.

## Warning Lamp for Air Filter Restriction

You must service the air filter if the air filter warning lamp illuminates when the engine is running. After the shift or at the end of the day, service the air cleaner. Make sure you check the condition of the warning lamp bulb each day before you operate the machine.

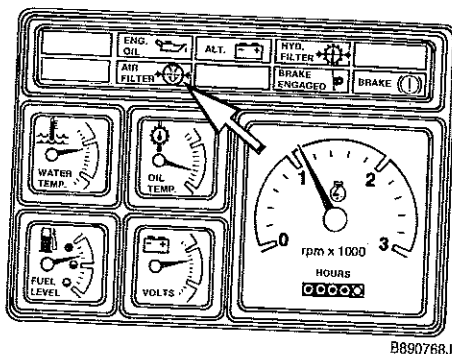

B890768J

## Primary (Outer) Element

Replace the primary (outer) element after three washings or after the element has been in the machine for one year. To service:

1. Raise the hood.
2. Loosen the wing nut on the end cover of the air filter. Remove the end cover.

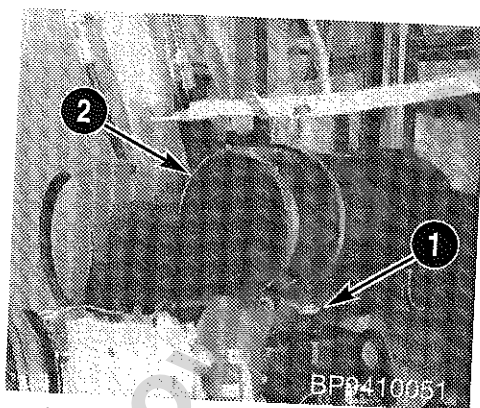

1. Wing Nut

2. End Cover

3. Carefully remove the primary (outer) element.

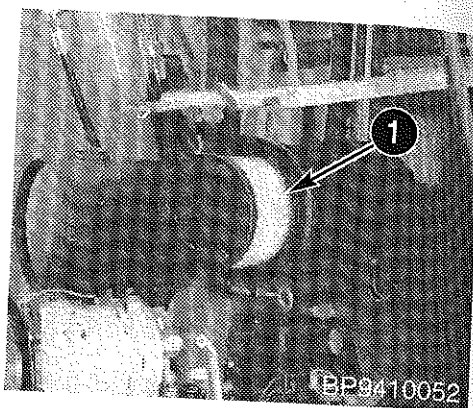

1. Primary (Outer) Element

4. Use a clean damp cloth and clean the inside of the filter body.
5. Install a clean or new primary (outer) element. Make sure the gasket is making full contact.
6. Install the end cover.
7. Tighten the wing nut on the end cover clamp.
8. Make sure other persons are clear of the machine. Start the engine and check the air filter warning lamp. If the lamp is still illuminated, replace the secondary (inner) element.

140

## Secondary (Inner) Element

Replace the secondary (inner) element (1) after the primary element has been cleaned three times, (2) after one year in the machine, or (3) after the primary element has been cleaned or replaced and the air filter warning lamp is still illuminated. DO NOT clean the secondary element.

1. Remove the end cover and remove the primary (outer) element.
2. Remove and discard the secondary element.

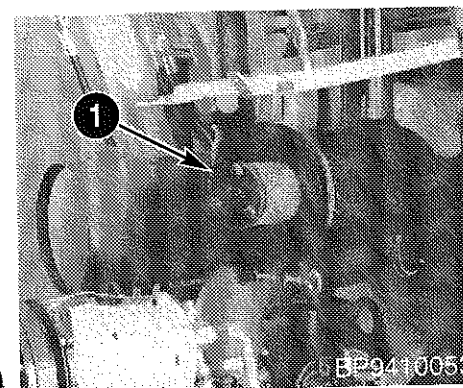

1. Secondary (Inner) Element

3. Use a clean damp cloth and clean the inside of the filter body.
4. Install a new secondary (inner) element. Make sure the gasket is making full contact.
5. Install the primary (outer) element and the end cover.

## Cleaning the Primary (Outer) Element

Check the dirty element for damage and check the rubber seal on the end. Push the rubber seal with your finger. If the rubber seal feels hard and does not move back to original shape, discard the element.

1. Wear face protection. Remove the loose dirt with compressed air at 207 kPa, 2.1 bar (30 psi) maximum. Hold the nozzle at least 25 mm (one inch) from the element to prevent damage.



CA5000J

2. Mix two tablespoons or one ounce (29.6 ml) of D1400 detergent (Case part number A40910) with 7.5 litres (two gallons) of water, or one cup or 236 ml (8 ounces) for 60 litres (16 gallons) of water.
3. Soak the element in the soap solution for 15 minutes and then move the element up and down rapidly to loosen as much dirt as possible.

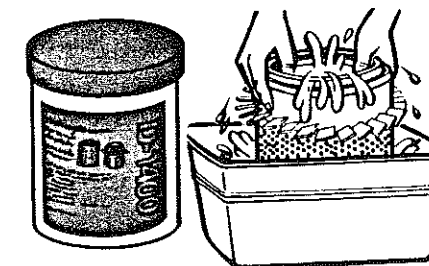

CA5001J

141

4. Use a water hose without a nozzle with pressure less than 275 kPa, 2.8 bar (40 psi) to remove all soap from the element.

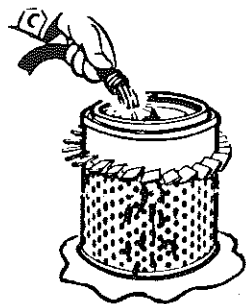

CA5002J

6. Use a light and inspect the element for holes or splits in the pleats. Check for damage to the metal parts and rubber gasket. Replace the element if damaged.

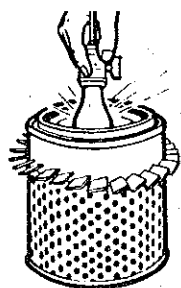

CA5003J

5. Allow the element to air dry. If you use an element drier, do not exceed 71°C (160°F) and make sure the air is circulating in the drier.

**NOTE:** If the clean and dry element is not to be used for some time, cover the element with paper for storage.

## ENGINE COOLING SYSTEM

### Service Specifications

Coolant Capacity - with heater .....	16.5 litres (17.4 U.S. quarts)
without heater .....	15.8 litres (16.7 U.S. quarts)

#### Interval

Reservoir Coolant Level Check .....	Every 10 hours of operation or each day
Radiator Coolant Level Check .....	Every 50 hours of operation
Check and Tighten Coolant Hose Clamps .....	As required
Coolant System Change .....	Every 2000 hours of operation (or once every two years, whichever occurs first)
Thermostat .....	83 to 95° C (181 to 203° F)
Radiator Cap .....	103 kPa, 1.0 bar (15 psi)

### Coolant Solution

A mixture of 50% ethylene glycol and 50% water must be used in this machine. This mixture is used if the lowest ambient temperature is above -37° C (-34° F). If the ambient temperature is lower, adjust the mixture.

**NOTE:** After you fill the cooling system, mix the ethylene glycol and water completely by running the engine at operating temperature for approximately five minutes. This procedure must be done when the machine is in temperatures below 0° C (32° F). If your machine is equipped with a cab and heater, make sure the heater is on.

## Coolant Levels

**WARNING:** Hot coolant can spray out if radiator cap is removed. To remove radiator cap:



Let system cool, turn to first notch, then wait until all pressure is released.

Scalding can result from fast removal of radiator cap. Check and service engine cooling system according to maintenance instructions.

SA023

### Coolant Reservoir Fluid Level

Check the coolant reservoir fluid level every 10 hours of operation or at the start of each day. Check the level when the coolant is cold and the engine is stopped. Do not remove the radiator cap during this check. The coolant level must be between the FULL and ADD marks on the reservoir. Add coolant as required to raise the coolant up to the FULL mark.

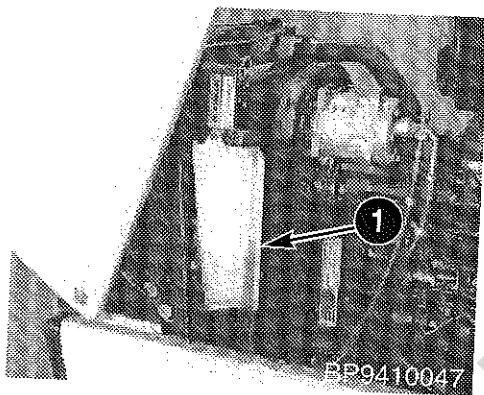

1. Coolant Reservoir

### Radiator

Check the coolant level every 50 hours of operation when the coolant is cold and the engine is stopped. The coolant level must be up to the radiator opening.

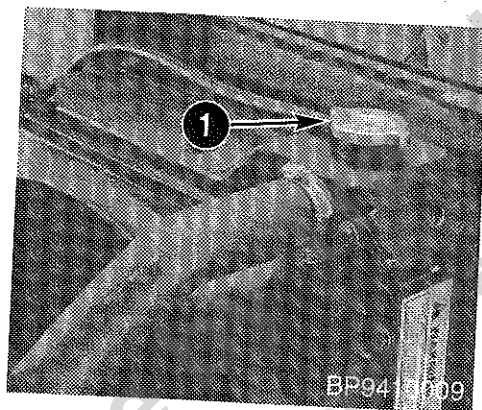

1. Radiator Cap

**NOTE:** If the radiator coolant level is low and the coolant reservoir level is at the FULL mark, check for air leaks in the hose between the radiator and the coolant reservoir.

## Cleaning the Cooling System

**WARNING:** Hot coolant can spray out if radiator cap is removed. To remove radiator cap:



Let system cool, turn to first notch, then wait until all pressure is released.

Scalding can result from fast removal of radiator cap. Check and service engine cooling system according to maintenance instructions.

SA023

Drain, flush, and replace the engine coolant every 2000 hours of operation or every two years, whichever occurs first. Clean the system and replace the coolant if the coolant becomes dirty or has the color of rust.

DO NOT remove the radiator cap if the coolant is hot. Allow the system to cool, then:

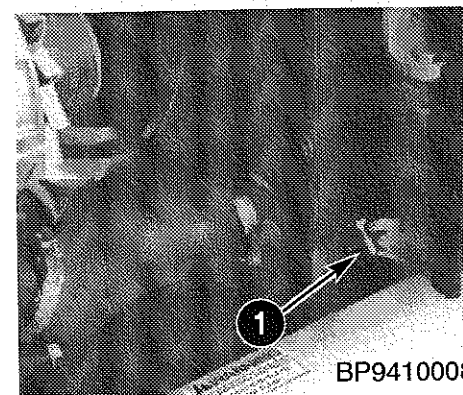

1. Radiator Drain Valve

1. Put a container under the drain valve that will hold 19 litres (5 U.S. gallon).
2. Open the radiator drain valve and remove the radiator cap.

3. After all coolant is removed, close the drain valve.
4. Add cleaning solution to the cooling system and fill the cooling system with clean water. Follow the directions included with the cleaning solution.
5. After you drain the cleaning solution, flush with clean water and drain the water.
6. Check the hoses, elbows, and water pump for leaks. Make sure the outside of the engine and radiator is clean.
7. Put a mixture of 50% ethylene glycol and 50% water in the radiator. Completely fill the radiator and coolant reservoir slowly to the neck with coolant.
8. Start the engine and increase the temperature of the engine coolant. When the coolant is at operating temperature, stop the engine and allow to cool. Check the coolant level at the coolant reservoir only. DO NOT remove the radiator cap.
9. Fill the coolant reservoir to the FULL mark as required and install the cap.

## DIESEL FUEL SYSTEM

### Service Specifications

Fuel Tank Capacity (Standard Machine) ..... 119 litres (31.4 U.S. gallons)

#### Interval

Draining Water from Main Filter ..... 50 hours

Draining Water from the Fuel Tank ..... 250 hours

Replacing the Main Fuel Filter and In-Line Fuel Filter ..... 500 hours

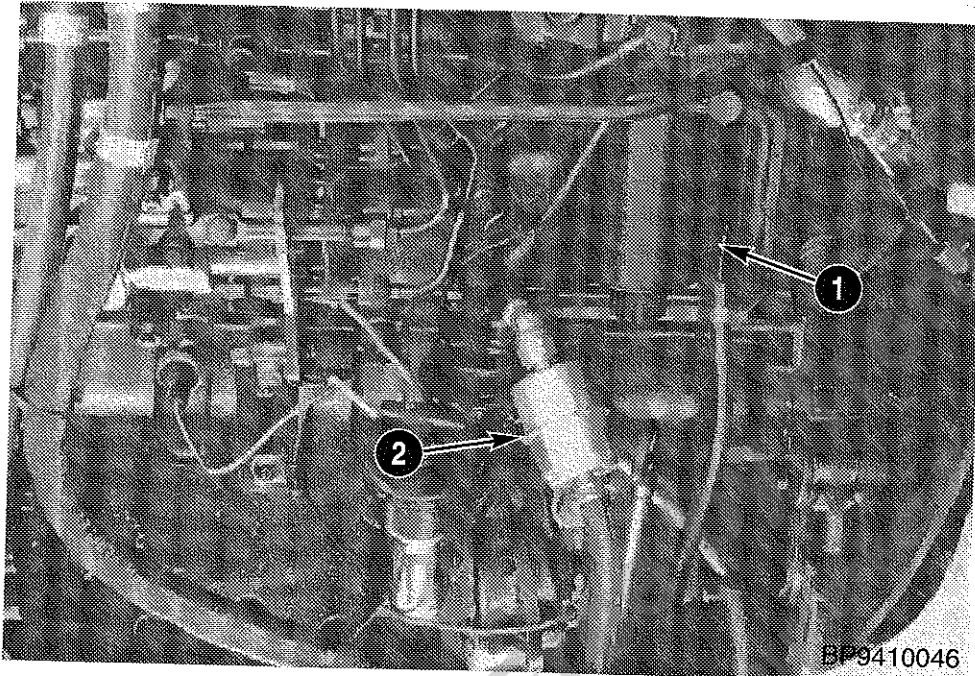

1. Main Fuel Filter

2. In-Line Fuel Filter

### Diesel Fuel Specifications

The best fuel for this machine is one which meets the ASTM D975 specification for grade 2-D. Where this fuel is not available, a premium, reduced sulfur fuel meeting the Engine Manufacturers Association fuel quality practice FQP-1 grade 2-D may be substituted. The use of other fuels can cause a loss of power and increased fuel consumption.

**NOTE:** When the temperature is very cold, the use of a mixture of 1-D and 2-D Diesel fuel is permitted. See your fuel dealer for winter fuel requirements in your area.

### Fuel Tank

Fill the fuel tank at the end of each day. A full tank will prevent water condensation. The use of Diesel Fuel Conditioner will also help this problem.

### Fuel Conditioner

Diesel fuel conditioner is available from your Case dealer. The conditioner will clean the fuel injectors, valves, and manifold; disperse insoluble gum deposits that form in the fuel system, separate moisture from the fuel and stabilize fuel in storage.

### Checking for Water or Sediment

Check the fuel filter for water or sediment every 50 hours of operation or each week. If after several checks no water is found, extend the interval.

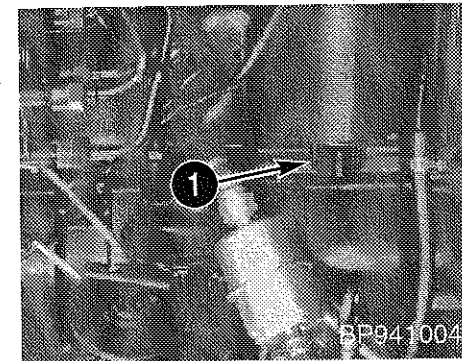

1. Water Drain

1. Hold a small glass container under the main filter and loosen the drain valve.

2. Remove a small amount of fuel and tighten the drain valve. Check the container for water and sediment. If no water is found, no further action is required.
3. If you find water or sediment, loosen the drain plug at the bottom of the fuel tank. After the water and sediment are removed, tighten the plug.

Check the fuel tank for water and sediment every 250 hours of operation.

### Replacing the In-Line Fuel Filter

1. Clean the area around the filter.

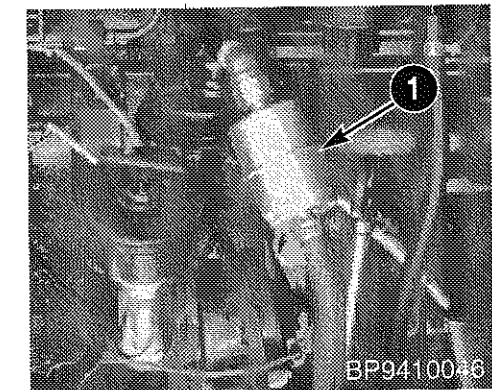

1. In-Line Fuel Filter

2. Loosen the upper nut and lower hose clamp for the in-line fuel filter. Prevent the lower hose from falling down and draining the fuel from the tank.
3. Remove the old filter and install a new filter.
4. Tighten the lower hose clamp and upper nut on the fuel filter.
5. Remove the air from the fuel system. See Page 148.

## Replacing the Fuel Filters

Replace both fuel filters every 500 hours of operation or if you have a loss of engine power.

1. Clean the area around the filter.
  2. Use a filter wrench and turn the filter counterclockwise to remove.
  3. Remove the rubber seal from the spud on the filter head.
  4. Use a cloth and clean the gasket surfaces of the filter body.
  5. Apply clean engine oil to the new rubber seal.
  6. Install the rubber seal on the filter head spud.
  7. Apply clean oil to the gasket of the new filter. Do not fill the new filter with fuel before installation.
  8. Turn the main filter clockwise onto the filter body until the filter gasket makes contact with the filter body. Continue to tighten the filter with your hand for 1/2 to 3/4 turn.
- IMPORTANT:** Do not use a filter wrench to tighten the filter. You can cause a leak if the filter is dented with the wrench.
9. Remove the in-line fuel filter and discard. Install a new in-line fuel filter. Make sure the hose clamp and nut are tight.
  10. Fill the tank with fuel.
  11. Remove the air from the fuel system. See the next topic "Removing Air From the Fuel System".

## Removing Air from the Fuel System

Air must be removed from the fuel system if one or more of the following conditions occurs:

- If the engine stops because of no fuel in the tank.
- If the fuel filters are replaced.
- If the fuel system has been serviced.
- If the machine has been in storage for three months or more.

1. Fill the fuel tank.
2. Loosen the air removal screw on the filter head two or three turns.

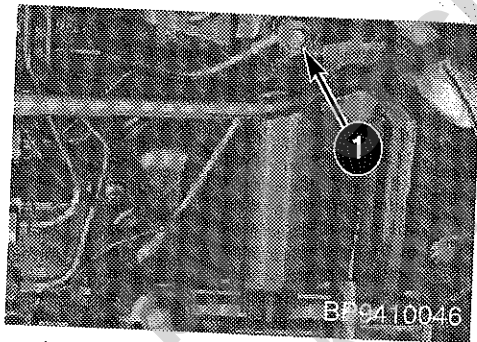

1. Air Removal Screw

3. Actuate the hand primer pump lever up and down. When fuel with no air flows from the air removal screw, tighten the air removal screw.

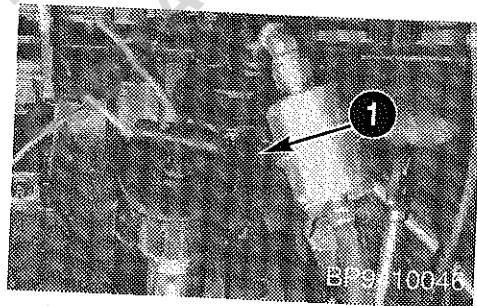

1. Hand Primer Pump

**NOTE:** If your machine is equipped with a turbocharger, do steps 7 through 9 to complete the bleeding procedure. If your machine does not have a turbocharger, complete steps 4 through 9.

4. Turn the key switch to ON.
5. Loosen the air removal screw on the injection pump 2 or 3 turns.

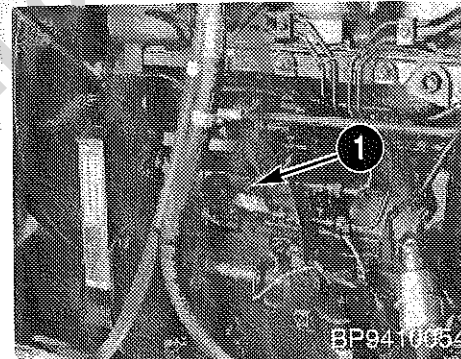

1. Air Removal Screw

6. Operate the hand primer until fuel with no air flows from around the fitting.
7. Tighten the air removal screw.
8. Lift up the hand primer lever to the STORAGE position.
9. Start the engine and check for fuel leaks.

## HYDRAULIC SYSTEM

### Service Specifications

Hydraulic Reservoir Refill Capacity	
With Filter Change.....	54.5 litres (14.4 U.S. gallons)
Without Filter Changer.....	52.6 litres (13.9 U.S. gallons)
Type of Fluid.....	Case TCH Fluid

#### Intervals

Fluid Level Check .....	50 hours or each day
Filter Replacement .....	1000 hours
Hydraulic Fluid Change .....	1000 hours



**WARNING:** Hydraulic fluid or grease injected into your skin can cause severe injury or death. Keep your hands and body away from any pressurized leak. Use cardboard or paper to check for a leak. If fluid is injected into your skin, see a doctor immediately.

SA024

### Fluid Level

Check the fluid level of the hydraulic system every 50 hours of operation or each week, whichever occurs first.

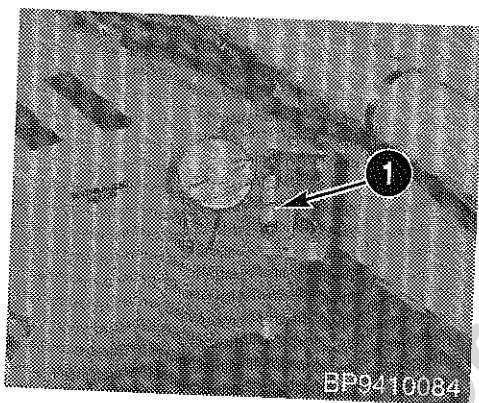

BP9410084

1. Hydraulic Reservoir Fluid Level

**IMPORTANT:** When the hydraulic fluid level is low, a small amount of hydraulic fluid will remain on the lower part of the sight gauge window. This condition does not show a correct fluid level.

1. Park the machine on a level surface.
2. Make sure the loader bucket is on the ground and the backhoe is in the transport position. Make sure the bottom of the loader bucket is parallel to the ground. Stop the engine.
3. Make sure the hydraulic fluid is cold when you check the level (fluid temperature the same as the outside air temperature).
4. The hydraulic reservoir is full when hydraulic fluid covers half of the sight gauge window.

### Hydraulic Filter

If the machine is new, replace the filter after the first 20 hours of operation. Then, replace the filter after every 1000 hours of operation or if the warning lamp for the hydraulic filter is illuminated.

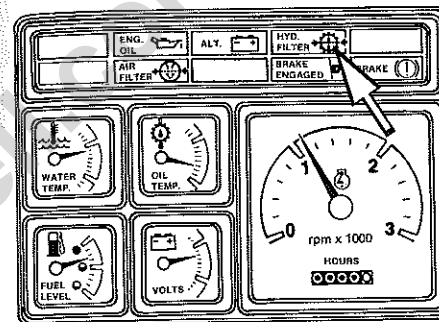

B890788J

### Procedure to Check the Condition of the Hydraulic Filter

1. Start the engine and raise the temperature of the hydraulic fluid to operating temperature (side of the hydraulic reservoir feels very warm). To increase the temperature of the hydraulic fluid, do the following:
  - A. Increase the engine speed to full throttle and roll back the loader bucket and hold the control lever in this position for 15 seconds.
  - B. After 15 seconds, move the control lever to the NEUTRAL position.
  - C. Repeat steps A and B until the side of the hydraulic reservoir feels very warm.

2. Increase the engine speed to full throttle. If the warning lamp for the hydraulic filter illuminates, replace the filter.

### Procedure to Replace the Hydraulic Filter

1. Lower the loader bucket to the ground and apply the parking brake.
2. Stop the engine.
3. Use a filter wrench and remove the old filter from the machine.

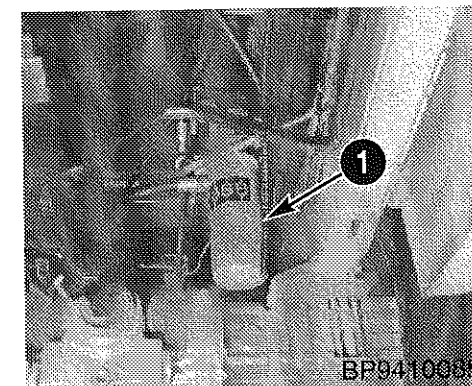

BP9410085

1. Hydraulic Filter

4. Lubricate the gasket on the new filter with clean oil.
5. Install the new filter and turn clockwise until the gasket contacts the head of the filter assembly. Continue to tighten the filter for 1/3 turn.
6. Start the engine and check for leaks at the hydraulic filter.

## Hydraulic Fluid Change

Change the hydraulic fluid every 1000 hours of operation.

1. Make sure the hydraulic fluid is at operating temperature.
2. Lower the loader bucket to the ground and put the backhoe in the transport position.
3. Stop the engine and put a Do Not Operate tag on the key switch.
4. Put a container under the drain plug that will hold 57 litres (15 U.S. gallons).

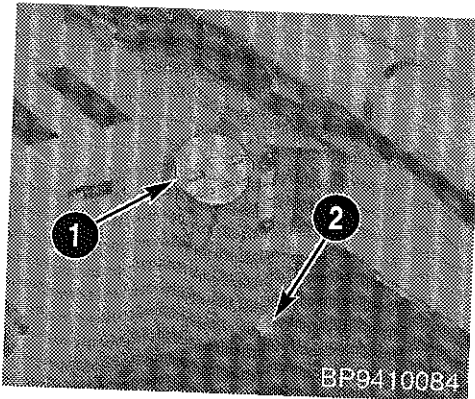

1. Fill Cap

2. Drain Plug

5. Remove the fill cap and remove the drain plug. Drain the hydraulic fluid from the hydraulic reservoir.
6. Install the drain plug.
7. Put new Case TCH fluid into the reservoir.
8. Start the engine and operate the loader and backhoe controls for three to four minutes. Stop the engine and check for leaks. Check the fluid level.

**IMPORTANT:** When the hydraulic fluid level is low, a small amount of hydraulic fluid will remain on the lower part of the sight gauge window. This condition does not show a correct fluid level.

## Pump Charge Procedure

If the hydraulic fluid supply to the pump has been interrupted due to hydraulic fluid change, pump replacement, or a broken line, see the Service Manual or your Case dealer for proper start up procedure.

## TRANSMISSION

### Service Specifications

#### Transmission Capacities

2 Wheel Drive	
Total System .....	18.5 litres (19.5 U.S. quarts)
Refill Capacity With or Without Filter Change .....	16.0 litres (16.9 U.S. quarts)

4 Wheel Drive	
Total System .....	21 litres (22 U.S. quarts)
Refill Capacity With or Without Filter Change .....	18.5 litres (19.5 U.S. quarts)

Type of Fluid ..... Case Hy-Tran Plus®

#### Interval

Fluid Level Check .....	250 hours
Filter Replacement .....	1000 hours
Transmission Breather Cleaning .....	1000 hours
Transmission Fluid Change .....	1000 hours

### Fluid Level

Check the fluid level of the transmission after the first 20 hours of operation with a new machine. Then check the fluid level every 250 hours of operation.

Check the fluid level when the machine is parked on level ground and with the engine running.

**WARNING:** Rotating fan and belts: Contact will cause injury. Keep clear.

SB071

The fluid level must be between the ADD and FULL marks on the dipstick. If the fluid level is at the ADD mark, add fluid as required until the fluid level is at the full mark.

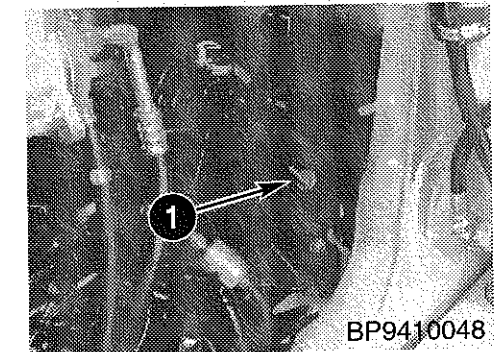

1. Transmission Dipstick

## Transmission Fluid Change, Filter Replacement, and Breather Cleaning

Change the transmission fluid, replace the transmission filter, and clean the breather every 1000 hours of operation.

1. Put a container under the drain plug that will hold 22.7 litres (6 U.S. gallons).
2. Remove the dipstick and the drain plug.

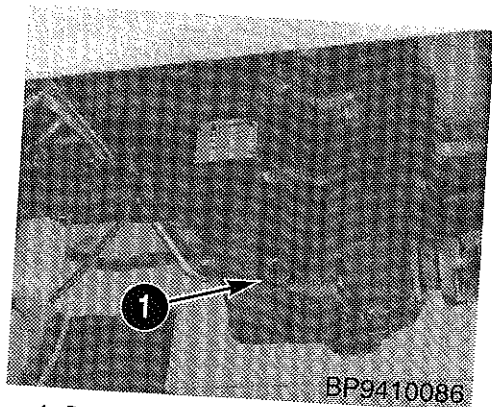

BP9410086

1. Drain Plug

3. Remove the old filter and discard. Clean the filter mounting surface with a clean cloth.

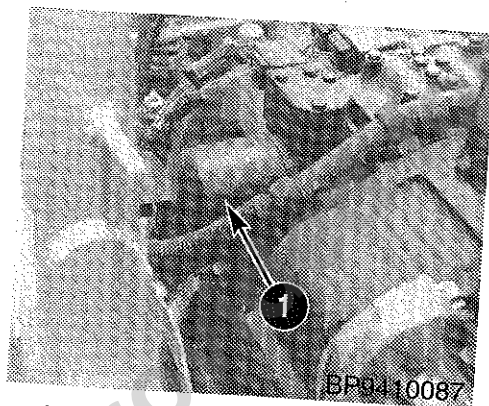

BP9410087

1. Transmission Filter

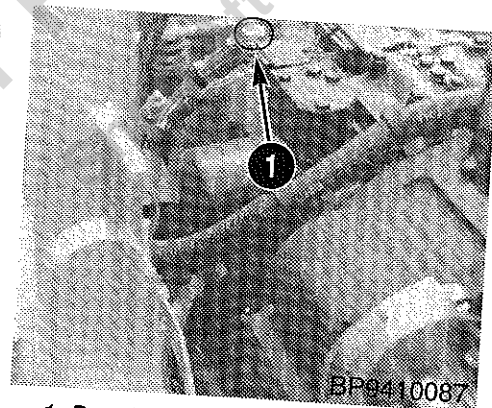

BP9410087

1. Breather

4. Lubricate the gasket of the new filter with clean oil.
  5. Install the new filter and turn clockwise until the gasket contacts the head of the filter assembly. Continue to tighten the filter for 1/3 turn.
- IMPORTANT:** Do not use a filter strap wrench to install the filter. A fluid leak can occur if the filter is dented by the filter strap wrench.
6. Install the drain plug. Put new Case Hy-Tran Plus® fluid into the transmission.
  7. Start the engine and check for leaks around the filter.
  8. Operate the machine in first and second gear for a few minutes. Park the machine on a level surface. With the engine running at idle speed, check the fluid level. Add fluid as required.
  9. Clean the area around the breather.
  10. Remove and clean the breather with solvent every 1000 hours of operation. Wear face protection, blow dry with compressed air, and install the breather.

## REAR AXLE

### Service Specifications

Axle Refill Capacity - 580L and 580 Super L	
Center Bowl (Differential).....	14.2 litres (15 U.S. quarts)
Each Wheel End (Planetary).....	1.5 litres (1.6 U.S. quarts)

Axle Refill Capacity - 590 Super L	
Center Bowl (Differential).....	14.2 litres (15 U.S. quarts)
Each Wheel End (Planetary).....	2.0 litres (2.1 U.S. quarts)

Type of Oil	
580L and 580 Super L Axle No. 114367A2 and 114367A3.....	MS 1317
580L and 580 Super L Axle No. 114367A4 and after.....	MS 1207
590 Super L Axles No. 127599A2.....	MS 1317
590 Super L Axle No. 127599A3 and after .....	MS 1207

Interval	
Oil Level Check .....	250 hours
Axle Breather Cleaning .....	250 hours
Oil Change .....	1000 hours

### Oil Temperature Lamp

The oil temperature warning lamp will illuminate when the temperature reaches 491°C (305°F). If the lamp illuminates, select a lower transmission gear. If the lamp continues to illuminate, stop the machine and allow the axle oil to cool. Continuous hard braking can cause the axle oil temperature to rise, illuminating the lamp.

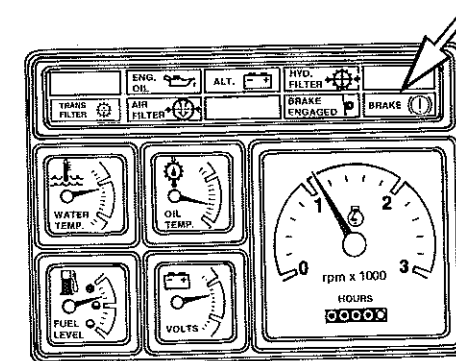

B890768J

## Type of Oil

You must choose the correct oil for the axle on your machine by using the chart on page 155. The number stamped on the axle will determine the type of oil for your machine.

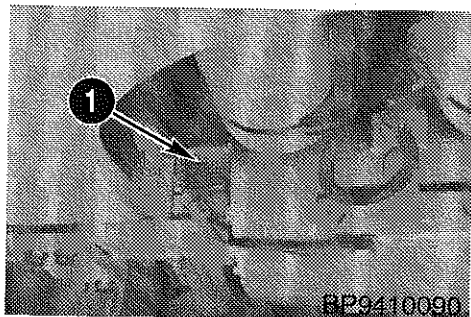

1. Axle P.I.N. Number

**IMPORTANT:** Use only MS1317 oil in the 580L and 580 Super L rear axles with the numbers 114367A2 and 114367A3 and the 590 Super L axle with the number 127599A2. **Damage can result to axle components if any other type of oil is used in these axles.**

Some axles may have been reworked and the last digit on the axle number changed to a higher number. Use the type of oil that matches the latest number.

## Oil Level

Check the oil level of the rear axle after the first 20 hours of operation with a new machine. Then, check the oil level every 250 hours of operation. You must check the oil level of the center bowl and each planetary end.

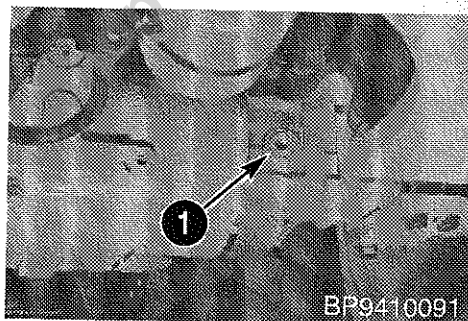

1. Center Bowl Oil Level Plug

1. Park the machine on a level surface. Make sure the direction control lever is in the NEUTRAL position and the gear shift control lever is in the NEUTRAL position.
2. Use the stabilizers to raise the rear wheels about 25 mm (one inch) above the ground.
3. Rotate the wheel so that the oil level plug is in the position shown.

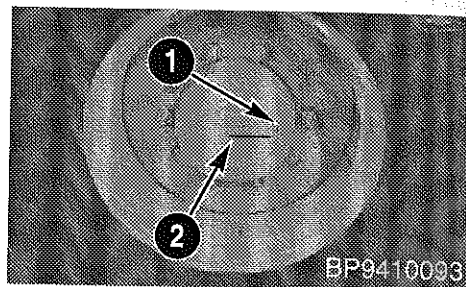

1. Oil Level and Drain Plug
2. Level Line

4. Remove the oil level plug. The oil level must be even with the plug hole. Replace the oil level plug.
5. Repeat steps 3 and 4 for the other side.
6. Lower the wheel to the ground.
7. Remove the plug from the center bowl. The oil level must be even with the plug hole. Replace the oil level plug.

## Oil Change

You must change the oil in the rear axle every 1000 hours of operation.

1. Park the machine on a level surface and make sure the oil in the rear axle is at operating temperature.
2. Make sure the direction control lever is in the NEUTRAL position and the gear shift control lever is in the NEUTRAL position.
3. Use the stabilizers to raise the rear wheels about 25 mm (one inch) above the ground.
4. Rotate the wheels so that the oil level plugs are in the correct position to drain the oil. Lower the wheels to the ground.
5. Stop the engine.
6. Put a pan under each planetary and the drain plug for the center bowl.
7. Remove the three drain plugs and remove the oil from each planetary and from the center bowl.

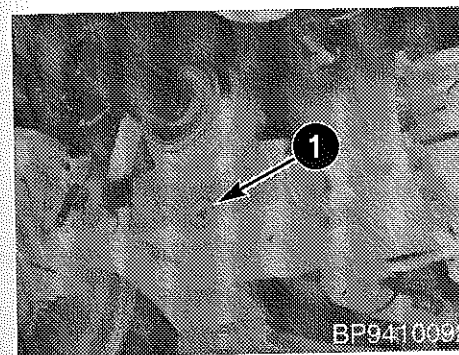

1. Center Bowl Drain Plug

8. Install the drain plugs and put the specified amount of oil in each planetary end and in the center bowl. See Specifications on page 155.

## Breather

Clean the breather for the rear axle every 250 hours of operation. If you operate the machine during severe operating conditions, clean the breather more frequently.

Remove the dirt from the area around the breather and clean the breather with solvent. Wear face protection and blow dry with compressed air.

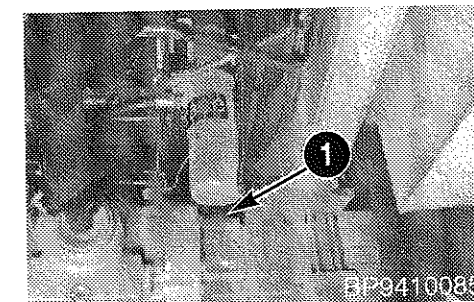

1. Breather

## FRONT FOUR WHEEL DRIVE AXLE

### Service Specifications

Axle Refill Capacity - 580L and 580 Super L	
Center Bowl (Differential).....	5.5 litres (5.8 U.S. quarts)
Each Planetary End .....	0.71 litres (0.75 U.S. quarts)
Axle Refill Capacity - 590 Super L	
Center Bowl (Differential).....	6.5 litres (6.9 U.S. quarts)
Each Planetary End .....	1 litres (.05 U.S. quarts)
Type of Oil .....	MS 1317
Interval	
Oil Level Check .....	250 hours
Axle Breather Cleaning .....	250 hours
Oil Change .....	1000 hours

### Oil Level

Check the oil level of the front drive axle after the first 20 hours of operation with a new machine. Then, check the oil level every 250 hours of operation. You must check the oil level of the center bowl and each planetary end.

1. Park the machine on a level surface. Make sure the direction control lever is in the NEUTRAL position and the gear shift control lever is in the NEUTRAL position.
2. Use the loader and raise the front wheels about 25 mm (one inch) above the ground.
3. Rotate the wheel so that the oil level plug is in the position shown.

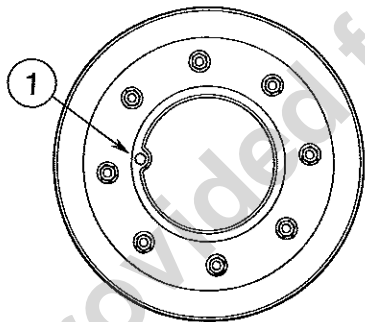

1. Oil Level and Drain Plug

B861835J

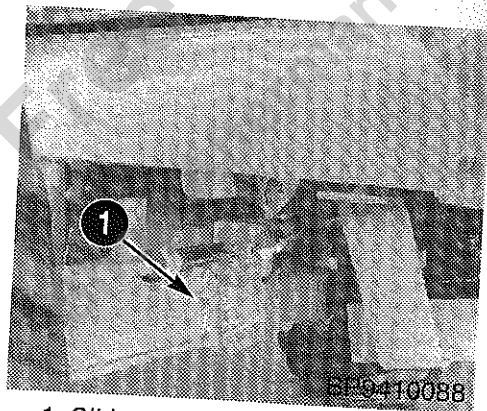

1. Oil Level Plug

4. Remove the oil level plug. The oil level must be even with the plug hole. Replace the oil level plug.
5. Repeat steps 3 and 4 for the other side.
6. Lower the wheels to the ground.
7. Remove the plug from the center bowl. The oil level must be even with the plug hole. Replace the oil level plug.

### Oil Change

You must change the oil in the front drive axle every 1000 hours of operation.

1. Park the machine on a level surface and make sure the oil in the front drive axle is at operating temperature.
2. Make sure the direction control lever is in the NEUTRAL position and the gear shift control lever is in the NEUTRAL position.
3. Use the loader to raise the front wheels about 25 mm (one inch) above the ground.
4. Rotate the wheels so that the oil level plugs are in the correct position to drain the oil. Lower the wheels to the ground.
5. Stop the engine.
6. Put a pan under each planetary and the drain plug for the center bowl.
7. Remove the three drain plugs and remove the oil from each planetary and from the center bowl.

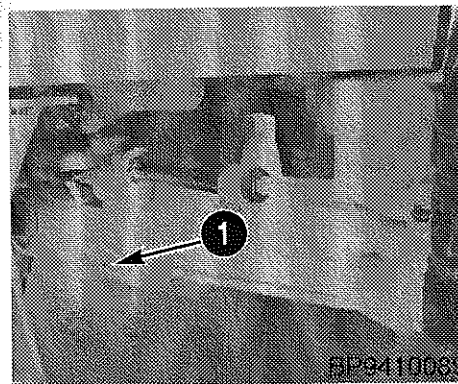

1. Center Bowl Drain Plug

8. Install the drain plugs and put the specified amount of MS 1317 in each planetary end and in the center bowl. See Specifications on page 158.

### Breather

Clean the breather for the front axle every 250 hours of operation. If you operate the machine during severe operating conditions, clean the breather more frequently.

Remove the dirt from the area around the breather and clean the breather with solvent. Wear face protection and blow dry with compressed air.

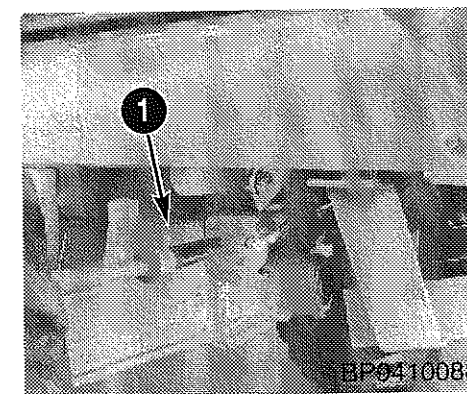

1. Breather

## CAB AIR FILTER

Clean the cab air filters (if equipped) every 1000 hours of operation or if the air flow in the cab is reduced.

1. Remove the mounting bolt.

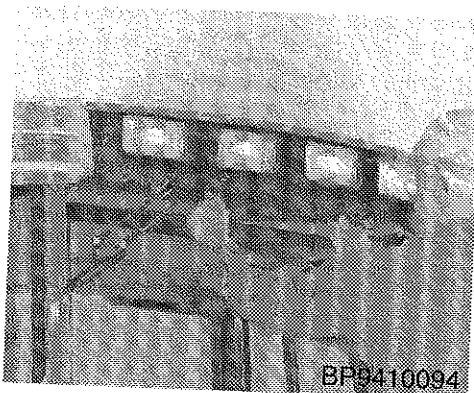

2. Remove rear screen.
3. Remove the recessed hex capscrew in the center.
4. Remove the air filters. Each filter is retained on the outer end by a clip. Slide the left-hand filter to the center and then remove out the left side. Remove the right-hand filter out the left side.
5. Use a cloth and clean the filter area.
6. Install the new or serviced filter. Make sure the arrows on the filter point toward the cab.
7. Install the cover, slide each locking plate inward, and tighten the mounting nuts.

### Cleaning the Filter

Check the dirty element for damage and check the rubber seal on the end. Push the rubber seal with your finger. If the rubber seal feels hard and does not move back to original shape, discard the element.

1. Be sure to wear face protection.

Remove the loose dirt with compressed air, 207 kPa, 2 bar (30 psi) maximum. Hold the nozzle at least 25 mm (one inch) from the element.

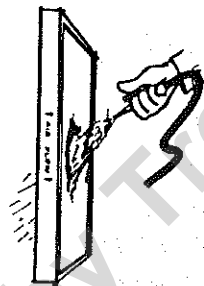

2. Mix two tablespoons or one ounce (29.6 ml) of D1400 detergent (Case part number A40910) with two gallons (7.6 litres) of water, one cup or 236 ml (8 ounces) for 60 litres (16 gallons) of water.
3. Soak the element in the soap solution for 15 to 20 minutes and then shake the element up and down rapidly to loosen as much dirt as possible.

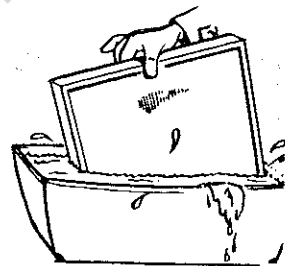

4. Use a water hose without a nozzle with pressure less than 275 kPa, 2.7 bar (40 psi) to flush all soap from the element.

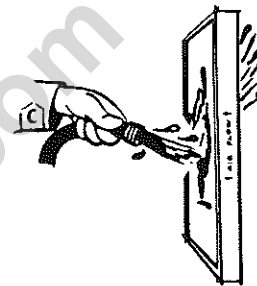

5. Allow the element to air dry. If you use a drier, do not exceed 71°C (160°F) and make sure the air is circulating in the drier.

6. Use a light and inspect the element for holes or splits in the pleats. Check for damage to the metal parts and rubber gaskets.

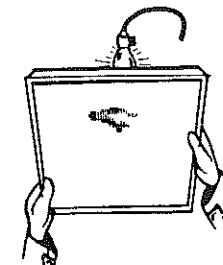

**NOTE:** If the element is not to be used for some time, wrap the element with paper for storage.

This page left blank

## MAINTENANCE AND ADJUSTMENTS

### LOADER RETURN-TO-DIG ADJUSTMENT

1. Park the machine on a level surface and apply the parking brake.
2. Lower the loader bucket to the ground and make sure the bottom of the bucket is at the desired digging angle.



3. Stop the engine.

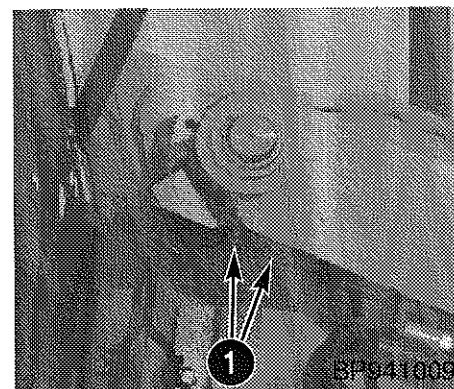

1. Adjusting Bolts

4. Loosen the adjusting bolts for the return-to-dig switch and move the switch in the slot so that the roller on the switch is resting on the edge of the cam on the loader arm.
5. Tighten the bolts.
6. Start the engine, raise the loader bucket to full height, and dump the bucket.
7. Put the loader control lever in the RETURN-TO-DIG position. The loader bucket will lower to the ground.
8. Check the position of the loader bucket. If the bucket is not in the correct position, see steps 9 and 10.
9. Move the return-to-dig switch rearward if the bucket did not roll back far enough.
10. Move the return-to-dig switch forward if the bucket rolled back too far.

**NOTE:** When moving the switch bracket forward or rearward for adjustment, be sure the bracket is pushed in toward the machine as the bolts are tightened. This will assure full contact of the switch with the actuating cam.

11. Repeat steps 6 through 10 until the bucket returns to the correct position.

## ETHER STARTING AID

### Replacing the Container



**WARNING:** Starting fluid (ether) can cause injury or death. An explosion can result if sparks, flame, or extreme heat contact the ether in the starting fluid container. Do not breathe starting fluid vapors. Wear face protection when you remove or install a starting fluid container or when you use an aerosol spray starting fluid. Use starting fluid according to instructions in this manual. SA039

1. Clean the ether starting aid container and base completely.
2. Loosen the clamp and turn the ether starting aid container counterclockwise.
3. Inspect the seal in the base. If the seal is damaged or worn, replace the seal.
4. Install the new ether starting aid container. Turn the container clockwise and tighten manually.

5. Tighten the clamp.

**NOTE:** During operation of the machine in warm weather, it is recommended that you remove the ether starting aid container from the machine and install a cap on the base.

**IMPORTANT:** See the instructions on pages 69 and 70 for correct use of ether. Also, read the instructions on the ether can.

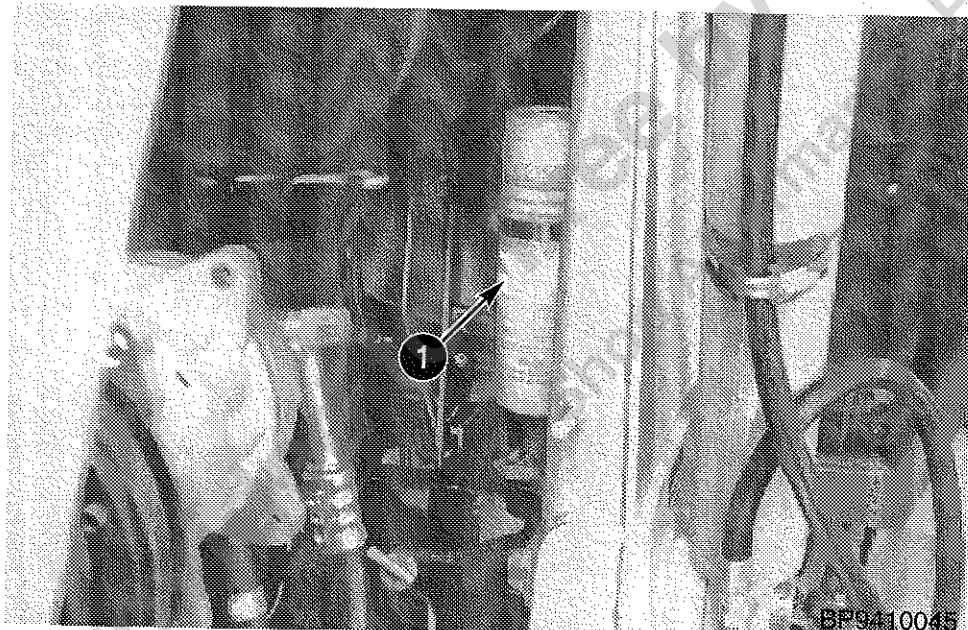

1. Ether Starting Aid Container

## FAN DRIVE BELT REPLACEMENT

1. Park the machine on a level surface and apply the parking brake.
2. Raise the loader lift arms to full height and install the loader lift arm support strut on the cylinder rod. See page 116.
3. Stop the engine, remove the key, and open the hood.
4. Install a 1/2 inch breaker bar in the tension pulley bracket.
5. Push the breaker bar forward just enough to release the tension on the drive belt. Remove the drive belt from the water pump pulley first and then from the other pulleys.
6. Remove the four cap screws, flat washers, and lock washers that fasten the pump drive coupling to the crankshaft pulley.
7. Move the pump drive coupling toward the hydraulic pump.
8. Remove the old drive belt.
9. Install the new drive belt on the water pump pulley and crankshaft pulley.
10. Align the coupling with the crankshaft pulley.
11. Install the cap screws, flat washers, and lock washers that fasten the coupling to the crankshaft pulley. Tighten the cap screws from 95 to 114 Nm (70 to 85 pound-feet).
12. Use the breaker bar to move the tension pulley bracket just far enough to install the drive belt on the alternator pulley.
13. Remove the breaker bar and close the hood.
14. Lower the loader bucket to the ground.

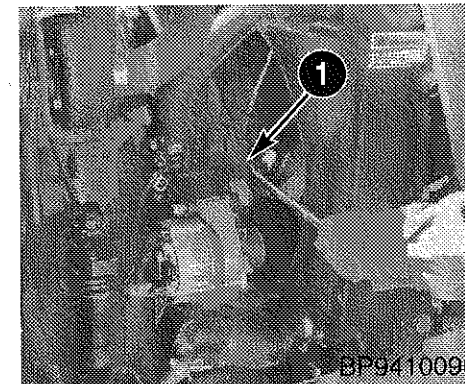

1. Tension Pulley Bracket

5. Push the breaker bar forward just enough to release the tension on the drive belt. Remove the drive belt from the water pump pulley first and then from the other pulleys.

## PLASTIC AND RESIN PARTS

Avoid using gasoline, paint thinner, etc., when cleaning plastic parts, console, instrument cluster, etc. Use only water, mild soap, and a soft cloth when you clean these parts.

Using gasoline, thinners, etc., can cause discoloration, cracking, or deformation of the part being cleaned.

## SPARK ARRESTER MUFFLER (IF EQUIPPED)

**WARNING:** The spark arrester is not intended to be used in closed areas where there is dust or vapor that can cause an explosion. SB025

Clean the spark arrester muffler every 100 hours of operation.

1. Stop the engine and make sure the loader bucket is on the ground.
2. Open the hood.
3. Remove the plug from the side of the muffler.

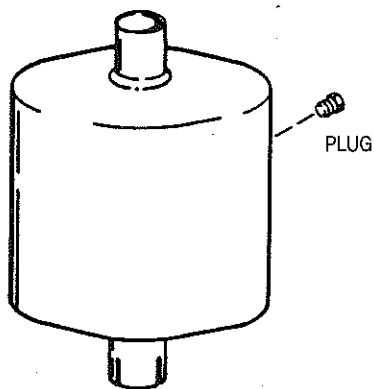

B861829J

4. Apply the parking brake and disconnect the wire to the injection pump solenoid on the engine.

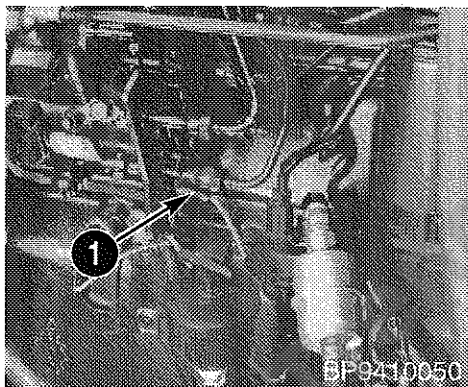

1. Wire to Injection Pump Solenoid

5. Be sure to wear face protection for this step. Have another person hold a block of wood over the muffler outlet.
6. Turn the key switch to START for approximately 30 seconds.
7. Turn the key switch to OFF.
8. Connect the wire to the injection pump solenoid and install the plug in the muffler.
9. Close the hood.

## RIDE CONTROL ACCUMULATOR

If the ride control accumulator must be replaced for any reason, always follow the instruction on the decal located on the accumulator mounting plate.

Never disconnect the hydraulic line between the accumulator and the solenoid valves without first discharging all hydraulic pressure from the hydraulic system. Always refer to the accumulator decal located at the right, in the safety section of this manual or the decal located on the accumulator mounting plate.

Refer to the service manual for complete instructions on testing the accumulator and solenoid.

### **WARNING**

#### **PRESSURE ACCUMULATOR IN LOADER HYDRAULIC SYSTEM**

DISCHARGE HYDRAULIC PRESSURE PRIOR TO DISCONNECTING HYDRAULIC LINES. ESCAPING HYDRAULIC OIL UNDER PRESSURE COULD CAUSE INJURY.

- REFER TO THE SERVICE MANUAL. PRECHARGE ONLY WITH DRY INERT GAS SUCH AS HIGH PURITY NITROGEN.
- REFER TO THE SERVICE MANUAL. DISCHARGE ALL GAS PRESSURE PRIOR TO DISASSEMBLING THE ACCUMULATOR.

256318A1

**WARNING:** The accumulator on this machine contains highly pressurized nitrogen gas. If the accumulator system does not function correctly, replace the accumulator. DO NOT attempt to repair the accumulator, only install a new one. Injury or death can result if you do not follow these instructions. SA142

## CAB AIR CONDITIONING

### Lubrication of the Air Conditioning Compressor Seals

Operate the air conditioning once every 250 hours to lubricate the compressor seals. Turn the air conditioning control to MAXIMUM for at least 15 minutes. In temperatures below 0°C (32°F) put a cover over the air conditioning condenser. This will make sure the refrigerant and lubricants in the system will be at operating temperature.

### Air Conditioning Compressor

**WARNING:** Rotating fan and belts: Contact will cause injury. Keep clear.

SB071

#### Belt Tension

Check the tension of a new drive belt after the first 10 hours of operation. Then, check the tension of the drive belt every 250 hours of operation.

Check the belt with a belt tension gauge, and adjust the belt to 20 to 25 kg (45 to 55 pounds).

#### Belt Adjustment

1. Lower the loader bucket to the ground and stop the engine.
2. Open the hood.
3. Loosen the pivot bolt of the air conditioner compressor.
4. Loosen the adjusting bolts.
5. Move the compressor out to tighten the belt. Tighten the adjusting bolts when the tension is correct.

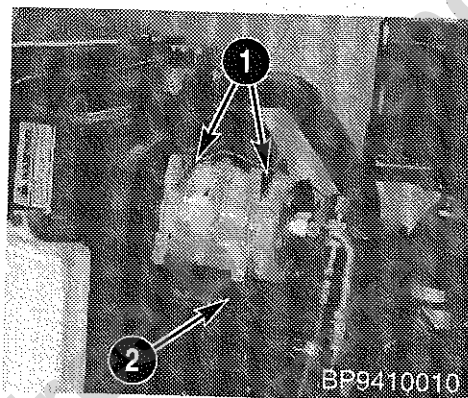

1. Adjusting Bolts
2. Pivot Bolt

6. Tighten the pivot bolt.
7. Close the hood.

## ROLL-OVER PROTECTIVE STRUCTURE

Your machine has a roll-over protective structure (ROPS). A ROPS label is fastened to the structure. The ROPS label shows the serial number of the ROPS, gross weight, approval, regulation and model numbers of the machine.

### ROPS Canopy Label

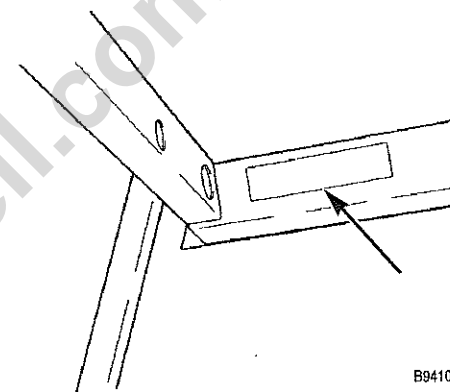

### ROPS Cab Label

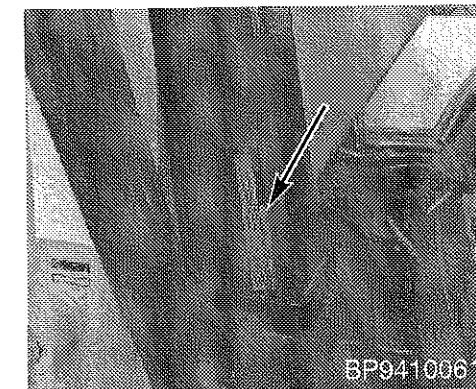

### Seat Belt

The seat belt is an important part of your ROPS. You must wear the seat belt at all times when you operate the machine.

Before you operate the machine, always make sure that the ROPS and operator's seat belts are correctly installed.

Keep sharp edges and items that can cause damage, away from the belts. From time to time check belts, buckles, retractors, tethers, slack take-up system and mounting bolts for damage.

Replace all parts that have damage or wear. Replace belts that have cuts that can make the belt weak.

Keep seat belts clean and dry.

Clean belts only with a soap solution and warm water. Do not use bleach or dye on the belts because this can make the belts weak.

### Maintenance and Inspection of ROPS

1. Check the torque of the ROPS mounting bolts. If necessary, tighten the bolts to the correct torque. See page 171.
2. Check the operator's seat and the mounting parts for the seat belt. Tighten the bolts to the correct torque. See page 172. Replace the parts that have wear or damage.
3. Check for cracks, rust, or holes in the ROPS and ROPS parts. Age, weather, and accidents can cause damage to the ROPS and ROPS parts. If you have any doubt about the ROPS system, see your dealer.

### Damage to the ROPS

If the machine has rolled over or the ROPS has been in some other type of accident (such as hitting an overhead object during transport), you must replace the damaged ROPS components to get as much protection as you had originally.

After an accident, check the following for damage.

1. ROPS cab or ROPS canopy.

2. Lower ROPS frame.
3. Operator's seat.
4. Seat belt mounting and seat belt.

Before you operate the machine, replace all ROPS components that are damaged.

See the parts catalog or your dealer for components that are replaceable.

**DO NOT TRY TO WELD OR STRAIGHTEN THE ROPS.**



**WARNING:** Improper ROPS inspection or maintenance can cause injury or death. Do the recommended ROPS inspection shown in this manual. If you must replace the ROPS, ROPS parts, or ROPS mounting hardware, use only the replacement parts shown in the Case parts catalog for this machine.

SA029



**WARNING:** Do not modify ROPS in any manner. Unauthorized modifications such as welding, drilling, cutting or adding attachments can weaken the structure and reduce your protection. Replace ROPS if subjected to roll-over or damage. Do not attempt to repair.

SB026



**WARNING:** If you operate this machine without a ROPS and the machine rolls over, you can be injured or killed. Remove the ROPS only for service or replacement. Do not operate this machine with the ROPS removed.

SA027



**WARNING:** Adding additional weight (attachments, etc.) to the machine can cause injury or death. Do not exceed the gross weight printed on the ROPS label.

SA028



**WARNING:** You are protected by the ROPS system on this machine (Roll-Over Protective Structure). The seat belt is an important part of that ROPS system. Before you operate this machine, always fasten the seat belt. If the machine rolls over and you **DO NOT** have the seat belt fastened, you can be crushed by the ROPS or the machine.

SA080

### Mounting Bolts for ROPS Canopy, ROPS Cab and Lower Frame

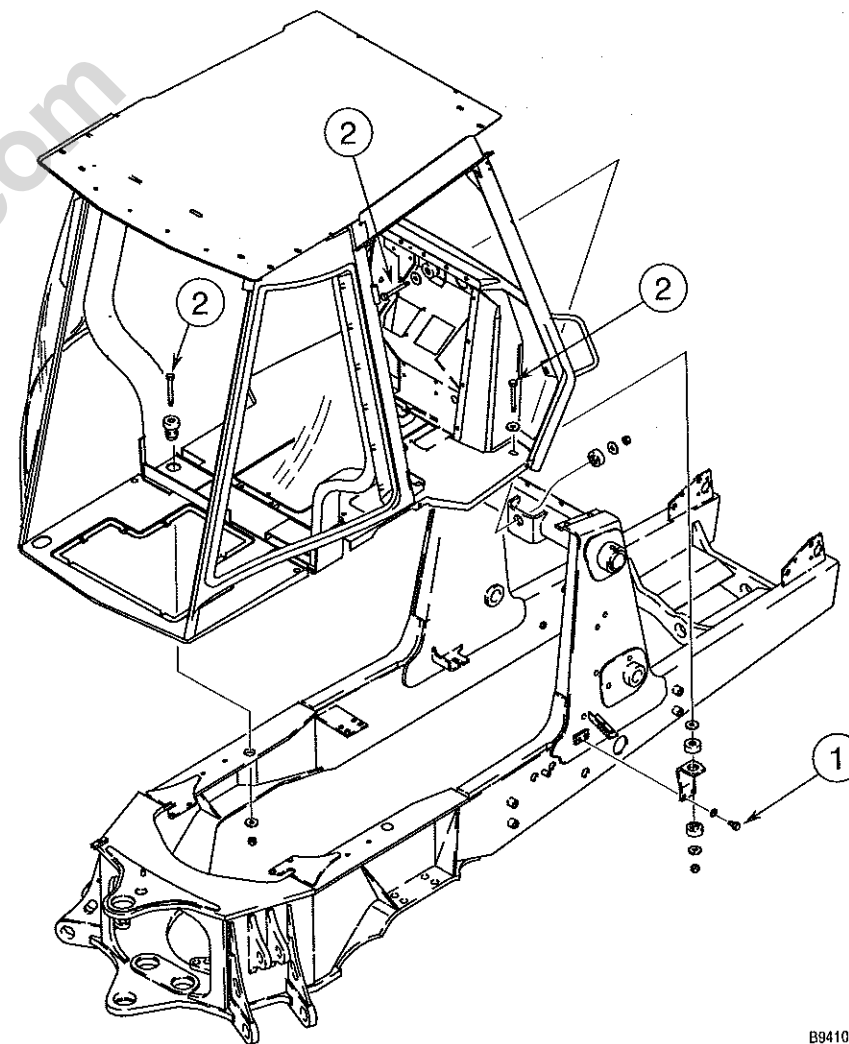

B9410088T

1. 125 to 150 Nm (93 to 112 pound-feet)
2. 298 to 358 Nm (220 to 264 pound-feet)

**NOTE:** These mounting bolts are the same for ROPS cab and ROPS canopy.

### Torque Specifications for Seat and Seat Belt Mounting Bolts

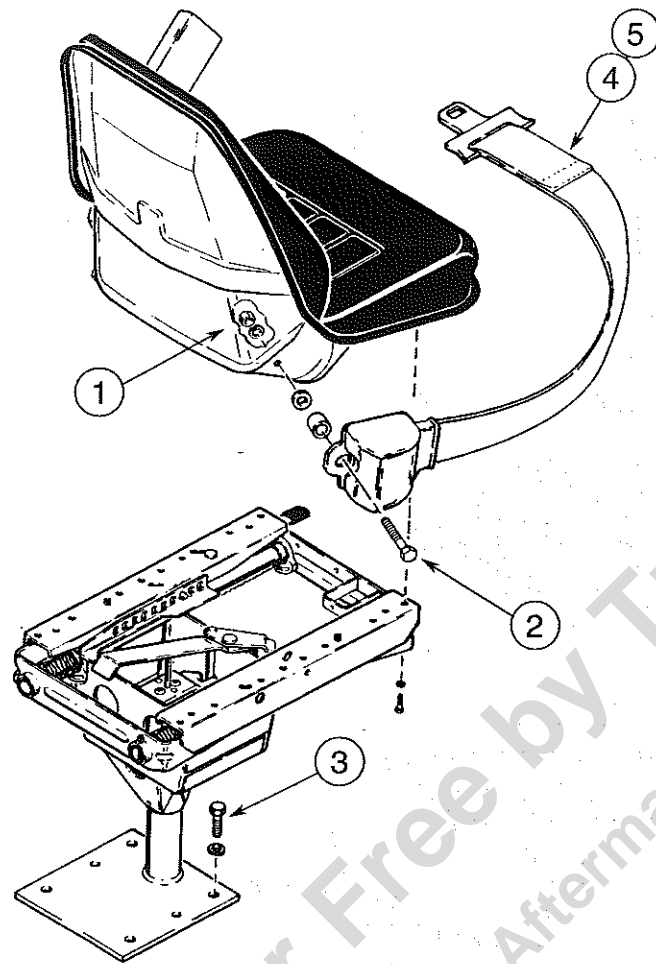

1. 73 to 87 Nm (54 to 64 Pound-Feet)
2. 23 to 28 Nm (17 to 21 Pound-Feet)
3. 109 to 130 Nm (80 to 96 Pound-Feet)
4. 51 mm (Two Inch) Seat Belt
5. 76 mm (Three Inch) Seat Belt

615L93

### FIRE EXTINGUISHER

#### Type of Fire Extinguisher

It is recommended that you have a fire extinguisher on your machine. The fire extinguisher shown below is available from your Case dealer and can be installed on the machine.

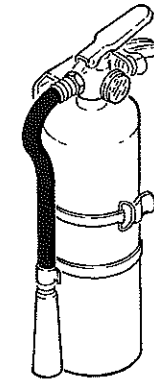

B9409008

#### Fire Extinguisher Mounting

For machines with cab the fire extinguisher can be mounted on the vertical surface to the right of the steering console. For machines with canopy the fire extinguisher can be fastened with hose clamps to the front right-hand ROPS post. Do not weld or drill on the ROPS.

#### Inspection and Care

**EVERY MONTH:** It is recommended that you inspect the fire extinguisher once each month for damage and to insure that the gauge is working correctly.

**ONCE EACH YEAR:** Have the fire equipment representative inspect the fire extinguisher. Reference NFPA Standard No. 10-1992.

**EVERY 6 YEARS:** Have the dry chemical removed and refilled by a fire equipment representative. Reference NFPA Standard No. 10-1992

**ONCE EVERY 12 YEARS:** Have the fire equipment representative hydrostatically test the fire extinguisher. Reference NFPA Standard No. 10-1992.

This dry chemical fire extinguisher (Case part number 549974C91) has a 5 pound capacity and is approved for class A, B, and C type fires. The operating temperature is from  $-54^{\circ}$  to  $49^{\circ}$ C ( $-65^{\circ}$  to  $120^{\circ}$ F).

This page left blank

## ELECTRICAL SYSTEM

### BATTERIES

#### Battery Safety



**WARNING:** Before you service a battery, always wear face protection, protective gloves, and protective clothing. Battery acid or battery explosion can cause serious injuries.

SA046



**WARNING:** Battery acid causes severe burns. Batteries contain sulfuric acid. Avoid contact with skin, eyes or clothing. Antidote - **EXTERNAL:** flush with water. **INTERNAL:** drink large quantities of water or milk. Follow with milk of magnesia, beaten egg or vegetable oil. Call physician immediately. **EYES:** flush with water for 15 minutes and get prompt medical attention.

SA032



**WARNING:** When the battery electrolyte is frozen, the battery can explode if, (1) you try to charge the battery, or (2) you try to jump start and run the engine. To prevent the battery electrolyte from freezing, try to keep the battery at full charge. If you do not follow these instructions, you or others in the area can be injured.

SA033



**WARNING:** Sparks or flame can cause hydrogen gas in a battery to explode. To prevent an explosion, do the following:

1. When you disconnect the battery cables, always disconnect the negative (-) battery cable first.
2. When you connect the battery cables, always connect the negative (-) battery cable last.
3. Do not short circuit the battery posts with metal items.
4. Do not weld, grind, or smoke near a battery.

SA034

#### Battery Service

**NOTE:** The electrical system in this machine is 12 volts.

Before you service components of the electrical system, always disconnect the negative (-) battery cables.

Do not run the engine with the battery cables disconnected or with the alternator wires disconnected.

Before using an electric welder, disconnect the alternator wires, instrument cluster, and battery(ies).

Do not use a steam cleaner or cleaning solvent to clean the alternator.

## One Battery System

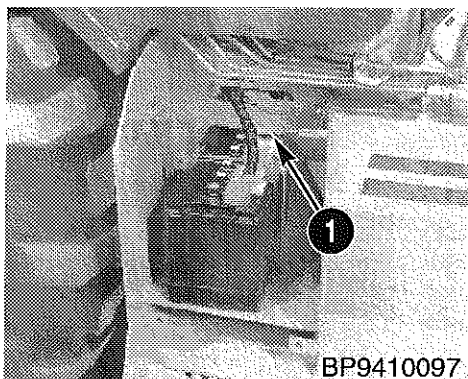

BP9410097

1. Negative (-) Terminal

## Two Battery System

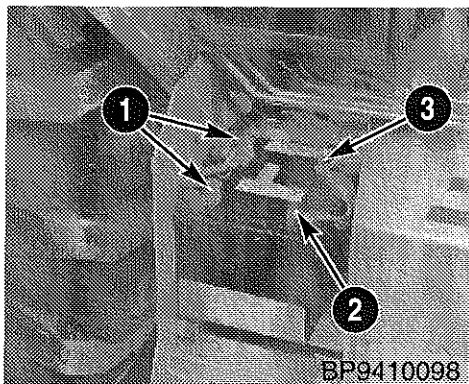

BP9410098

1. Positive (+) Terminal
2. Negative (-) Terminal
3. Negative (-) Terminal and Ground

## Battery Fluid Level

Check the fluid level of the batteries every 1000 hours of operation. If the fluid level is low, add clean or distilled water to each cell until the fluid level is 1/8 inch below the split ring at the bottom of each cell opening.

**IMPORTANT:** If the temperature is 0° C (32° F) or below and you have added water to the batteries, do the following: Connect a battery charger to the batteries or run the engine for approximately two hours. This procedure is necessary to mix the water with the electrolyte.

## Battery Vents

Keep the battery vents clean. Make sure the vents are not restricted.

## Cleaning the Batteries

Check the batteries regularly for dirt, corrosion and damage. Dirt mixed with electrolyte or moisture on the top of the battery, can cause a discharged condition in the battery. Wear face protection and use one of the following methods to clean the battery:

1. Use Case Battery Saver, part number M20376. Follow the instructions on the container. This cleaner does not require water.
2. Use baking soda or ammonia and flush the outside of the battery with water. If you do not have Case Battery Saver, use other special cleaners to prevent corrosion on the battery terminals.

## LAMP REPLACEMENT

### Flasher, Turn Signal, and Stop and Tail Lamp

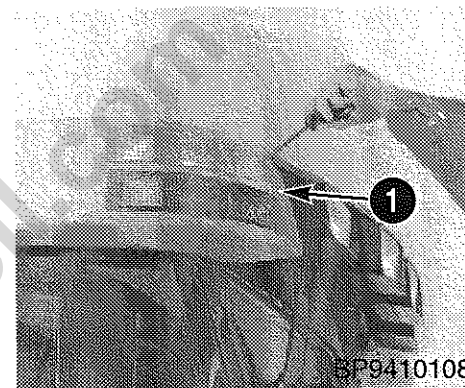

BP9410108

1. Remove Lens

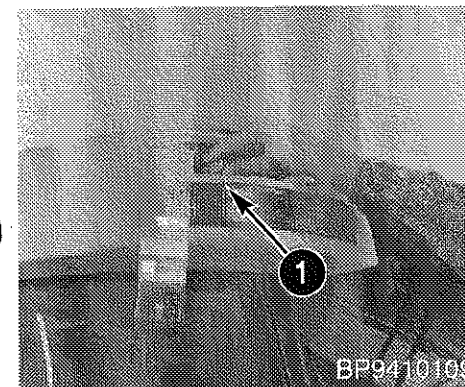

BP9410109

1. Replace Bulb

Flasher and Turn Signal - No. 1156 Bulb  
Stop and Tail Lamp - No. 1157 Bulb

### Dome Lamp

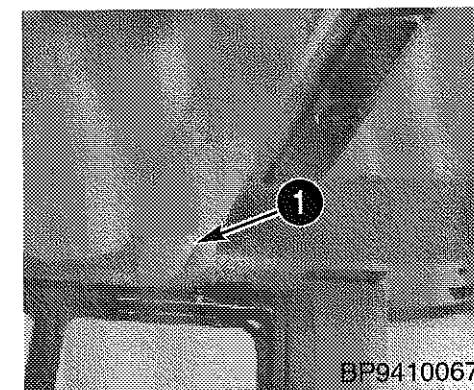

BP9410067

1. Remove Lens to Replace Bulb

No. 211 Bulb

### Driving and Flood Lamps

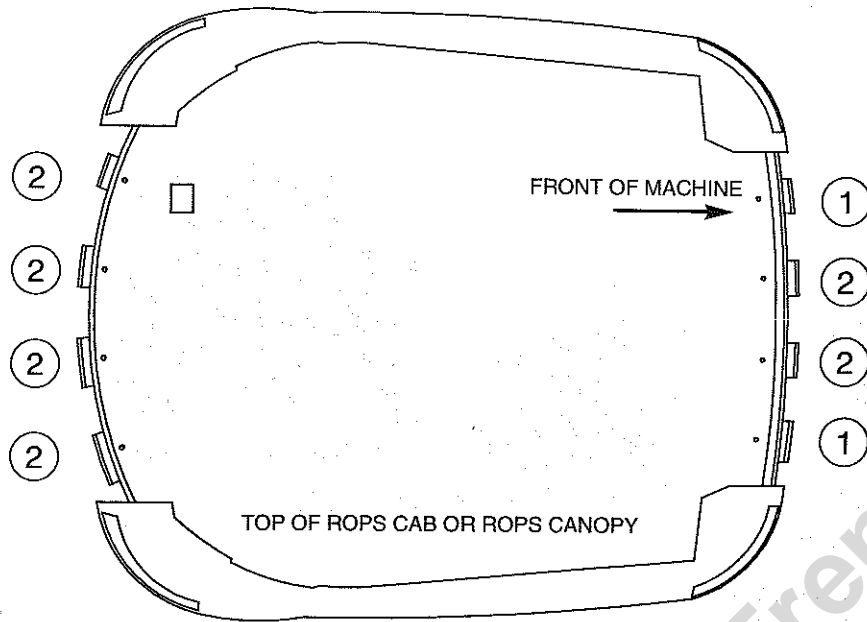

- 1. Driving Lamp - Case part number A187912
- 2. Flood Lamp - Case part number A187911

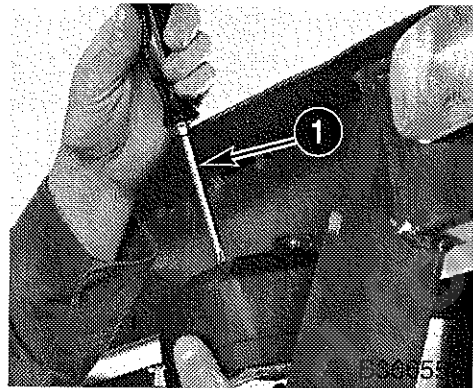

1. Remove Two Screws

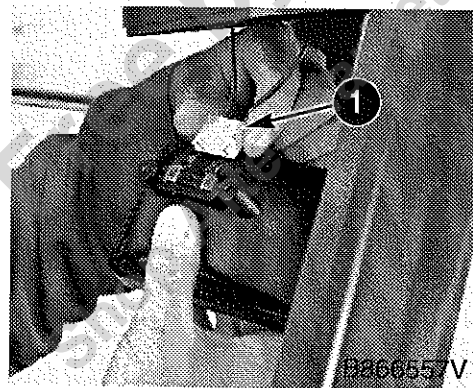

1. Disconnect and Discard Old Lamp

**VERTICAL ADJUSTMENT OF DRIVING AND WORK LAMPS:** The cross bolt in the lamp mounting bracket must be loosened before the lamp is moved. Moving the lamp without loosening the cross bolt can cause damage to the plastic housing, allowing the lamp to fall out of position.

### INSTRUMENT CLUSTER

Remove four screws and remove the instrument cluster. Turn the bulb holder counterclockwise to remove.

- Warning lamp replacement bulb ..... No. 168
- Instrument lamp replacement bulb ..... No. 194

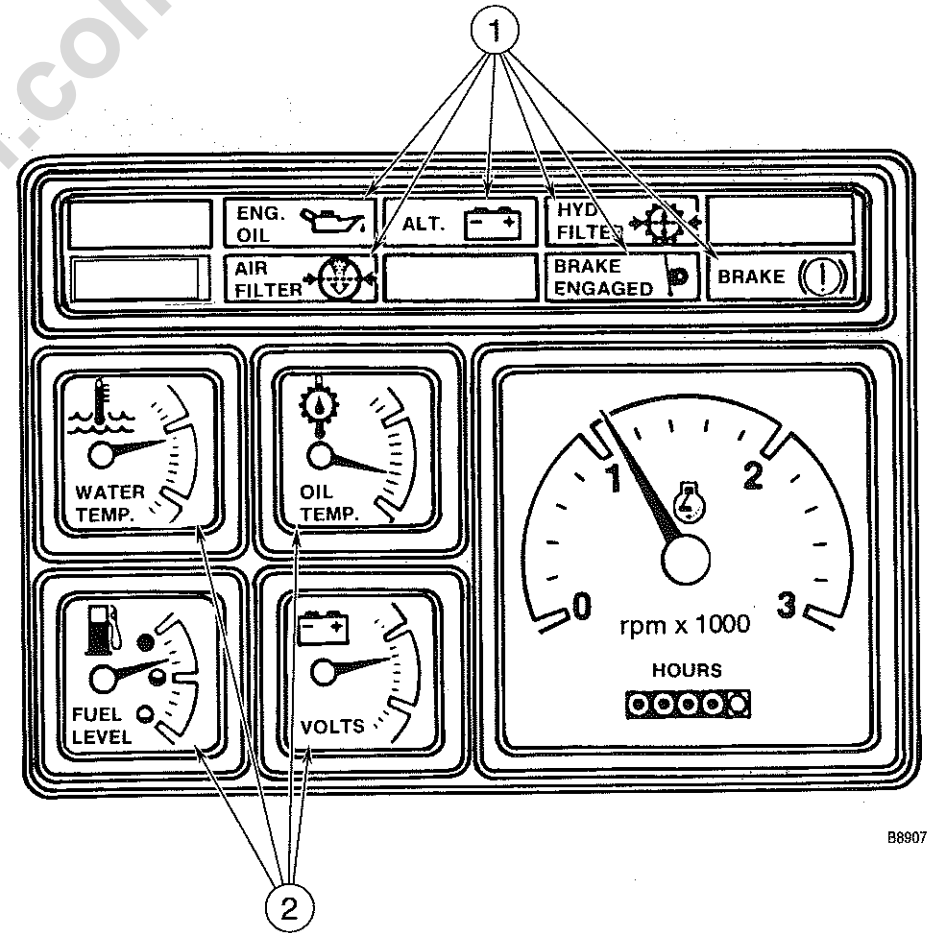

1. Warning Lamps

2. Instrument Lamps

## FUSES

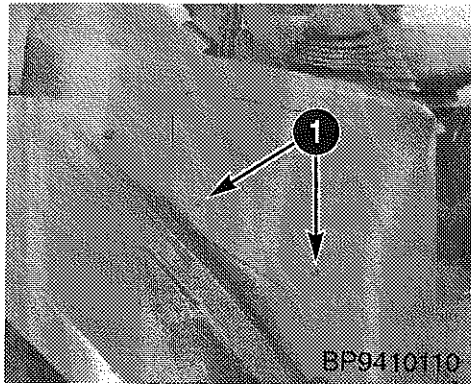

1. Remove Screws

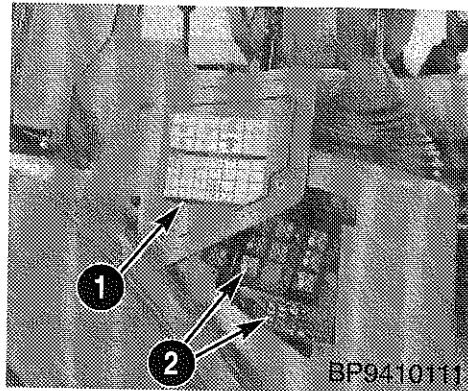
1. Fuse Location Decal Inside Cover  
2. Fuses In Place

REVERSE RELAY	FORWARD RELAY	REAR LIGHTS RELAY	STARTER RELAY		
ALARM RELAY #1	ALARM RELAY #2	CLUTCH RELAY	NEUTRAL RELAY		
AIR COND. RELAY	POWER RELAY #3	POWER RELAY #2	POWER RELAY #1		
RELAYS					
STARTING TRANSMISSION CONTROL 10A	INSTRUMENT CLUSTER 10A	REAR WORK LIGHTS 20A	FRONT WORK LIGHTS 10A	SPARE	SPARE
RADIO & C.B. REAR SIDE HYDRAULICS 10A	STOP FLASHER TURN SIGNAL 10A	BLOWER 20A	SPARE		
RADIO & C.B. (BATT) 10A	HORN 10A	DOOR LIGHT 10A	SPARE		
WIPERS 10A	4WD 10A	BEACON 10A	DRIVING LIGHTS 10A	STOP 10A	
FUSES					

B9410160S

## MACHINE STORAGE

## Storage Preparation

If the machine is to be in storage for more than 30 days, park the machine inside a building. If a building is not available, park the machine in a dry area on planks and cover the machine with a waterproof covering.

1. Wash the machine.
2. Lubricate the machine at all grease fittings.
3. Paint any area where the paint has been damaged.
4. Move all hydraulic controls to relieve any pressure in the hydraulic circuits.
5. Drain the fuel tank.
6. Put approximately 8 litres (2 U.S. gallons) of diesel flushing oil in the fuel tank. Run the engine until the exhaust smoke is blue white.
7. Drain the flushing oil from the fuel tank.
8. Put 4.93 ml (0.167 ounce) or one teaspoon of Shell Oil Company VPI crystals in the fuel tank.

9. Change the engine oil and replace the oil filter.
10. Drain the cooling system. Leave the drain valves open and do not tighten the radiator cap. Put a Do Not Operate tag on the steering wheel.
11. Clean or replace the primary element for the air filter.
12. Cover the exposed cylinder rods, equipment valve spools, etc., with Case Rust and Corrosion Preventive (Part Number B17510).
13. Charge the battery(ies). Remove the batteries from the machine and put the batteries on a wooden pallet in a cool dry area. If possible, keep the batteries in a building where the temperature is above freezing (0°C, 32° F). Make sure the batteries are clean.

**NOTE:** Check the battery(ies) periodically for the correct electrolyte level. Wear face protection and test the electrolyte with a hydrometer. When the hydrometer reading is near 1.215, charge the battery (ies).

## REMOVAL FROM STORAGE

Do not start the engine until steps 1 through 14 have been done.

1. Change the fuel filters.
2. Put coolant in the engine cooling system.
3. Check the condition of the drive belts. Replace if required.
4. Check the engine oil level.
5. Check the hydraulic oil level.
6. Check the transmission oil level.
7. Check the oil level of the rear axle.
8. Check the oil level of the front drive axle (If equipped).
9. Lubricate the machine at all grease fittings.
10. Use petroleum base solvent and remove the Case Rust and Corrosion Preventive from the hydraulic cylinder rods.
11. Install the battery(ies).
12. Fill the fuel tank.
13. Remove the air from the fuel system.
14. Lubricate the turbocharger. It is important that you use the procedure on page 67 for priming the turbocharger lines with oil.
15. Start the engine.

## SPECIFICATIONS

### TABLE OF CONTENTS

580L Specifications .....	page 183
580 Super L Specifications .....	page 203
590 Super L Specifications .....	page 227

### 580L SPECIFICATIONS

#### ENGINE DATA - 580L

Make and model.....	Case 4-390
Firing order .....	1-3-4-2
Air induction .....	Naturally Aspirated
Bore and stroke .....	102 x 120 mm (4.02 x 4.72 inches)
Displacement .....	3.92 litres (239 cu in)
Compression ratio .....	17.0 to 1
Fuel .....	See page 146
Horsepower - rated	
SAE net .....	70.6 at 2200 rpm (52.6 kW at 2200 r/min)
SAE gross .....	75 at 2200 rpm (55.9 kW at 2200 r/min)
Engine speeds	
Full throttle - no load .....	2325 to 2425 rpm
Full throttle - full load .....	2200 rpm
Idle speed .....	900 to 975 rpm
Loader hydraulic stall .....	2000 to 2300 rpm
Torque converter stall .....	1850 to 2300 rpm
Combined stall .....	1040 to 1500 rpm
Valve clearance - engine cold	
Intake valves .....	0.010 inch (0.254 mm)
Exhaust valves .....	0.020 inch (0.508 mm)

#### BOLT TORQUES

Front wheel mounting bolts (2 wheel drive) .....	156 to 203 Nm (115 to 150 pound-feet)
Front wheel mounting nuts (4 wheel drive) .....	270 to 352 Nm (200 to 260 pound-feet)
Rear wheel mounting nuts .....	129 to 136 Nm (95 to 100 pound-fee)

Then turn in the tightening direction an additional 55 to 65 degrees. This applies to the rear wheel nuts only.

**MAIN RELIEF VALVE PRESSURES - 580L**

Loader and backhoe ..... 207 + 7 - 0 bar  
(3 000 + 100 - 0 psi)

(The loader control valve controls the loader and backhoe hydraulic pressure.)

**TRAVEL SPEEDS - 580L**

**Measured with 17.5L x 24 Tires**

	1st km/h (mph)	2nd km/h (mph)	3rd km/h (mph)	4th km/h (mph)
Forward	5.54 (3.45)	10.00 (6.22)	19.22 (11.94)	38.39 (23.85)
Reverse	6.69 (4.16)	12.07 (7.50)	23.19 (14.41)	46.34 (28.79)

**NOTE:** (Travel speeds measured at 2 353 engine rpm with zero torque converter slip)

**Measured with 19.5L x 24 Tires**

	1st km/h (mph)	2nd km/h (mph)	3rd km/h (mph)	4th km/h (mph)
Forward	5.93 (3.68)	10.69 (6.64)	20.54 (12.76)	41.03 (25.50)
Reverse	7.15 (4.44)	12.90 (8.02)	24.78 (15.40)	49.53 (30.78)

**NOTE:** (Travel speeds measured at 2 353 engine rpm with zero torque converter slip)

**OPERATING WEIGHTS - 580L**

**Lightest Configuration**

2 083 mm (82 inch) standard loader bucket, 2WD, 17.5L x 24 rear tires, 11L x 16 front tires, no front counterweight, standard dipper, 610 mm (24 inch) general purpose backhoe bucket, cast stabilizer pads, non-suspension seat, ROPS canopy, single battery, no operator ..... 5 704 kg (12 575 pounds)

**Heaviest Configuration**

2 083 mm (82 inch) 4-in-1 loader bucket, 4WD, 19.5L x 24 rear tires, 12 x 16.5 front tires, 225 kg (500 pound) front counterweight, extendahoe, 610 mm (24 inch) HD backhoe bucket, flip over stabilizer pads, suspension seat, ROPS Cab, Air Conditioner, Dual Batteries, with a 79 kg (175 pound) operator, and mechanical front wheel drive guard ..... 6 915 kg (15 244 pounds)

**LOADER BUCKETS - 580L**

Width mm (Inch)	Type	Capacities SAE Heaped m <sup>3</sup> (cu yd)	Capacities Struck m <sup>3</sup> (cu yd)	Weight kg (lbs)
2083 (82)	Standard	0.79 (1.03)	0.67 (.87)	342 (650*)
2083 (82)	4-in-1	0.79 (1.04)	0.65 (.85)	663 (1462)

\*Add 47 kg (103 lbs) for bolt on cutting edge.

**BACKHOE BUCKETS - 580L**

Width mm (Inch)	Type	Capacities SAE Heaped m <sup>3</sup> (cu feet)	Capacities Struck m <sup>3</sup> (cu feet)	Weight kg (lbs)
305 (12)	Universal HD	0.068 (2.41)	0.082 (2.90)	141 (311)
406 (16)	Universal HD	0.083 (2.92)	0.101 (3.60)	157 (346)
457 (18)	Universal HD	0.094 (3.33)	0.122 (4.30)	163 (359)
610 (24)	Universal HD	0.135 (4.78)	0.181 (6.40)	195 (429)
762 (30)	Universal HD	0.176 (6.22)	0.245 (8.65)	225 (496)
914 (36)	Universal HD	0.217 (7.67)	0.306 (10.80)	259 (571)
610 (24)	H.D. Hi Capacity	0.195 (6.90)	0.241 (8.50)	196 (430)
457 (18)	G.P. Trenching	0.010 (3.57)	0.133 (4.70)	115 (255)
610 (24)	G.P. Trenching	0.135 (4.76)	0.177 (6.26)	136 (300)
762 (30)	G.P. Trenching	0.168 (5.95)	0.222 (7.83)	172 (380)

### BASIC MACHINE DIMENSIONS - 580L

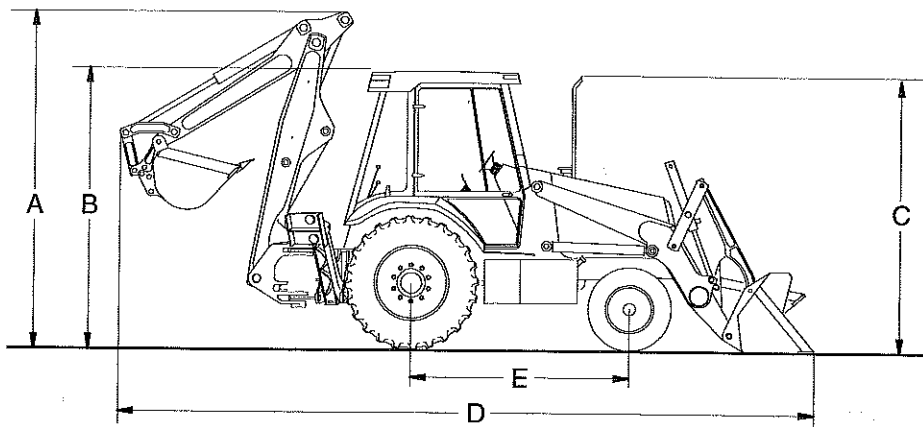

BT95J025

A	Overall height - backhoe in transport position	
	2 Wheel drive .....	3.41 m (11 ft 2.6 in)
	4 Wheel drive .....	3.40 m (11 ft 2.4 in)
B	Height to top of ROPS canopy	
	2 Wheel drive .....	2.66 m (8 ft 9.2 in)
	4 Wheel drive .....	2.66 m (8 ft 9.1 in)
B	Height to top of ROPS cab	
	2 Wheel drive .....	2.71 m (8 ft 11.1 in)
	4 Wheel drive .....	2.72 m (8 ft 11 in)
C	Height to top of exhaust stack	
	2 Wheel drive .....	2.63 m (8 ft 7.9 in)
	4 Wheel drive .....	2.62 m (8 ft 7.5 in)
D	Overall length - backhoe in transport position	
	2083 mm (82 inch) standard bucket .....	6.99 m (22 ft 11.9 in)
	2083 mm (82 inch) 4-in-1 bucket .....	6.92 m (22 ft 9.3 in)
E	Wheel base	
	2 Wheel drive .....	2 134 mm (84.0 inches)
	4 Wheel drive .....	2 146 mm (84.5 inches)
	Width over tires	
	11L x 16 tires .....	2 009 mm (79.3 inches)
	12 x 16.5 tires .....	2 060 mm (81.1 inches)
	19.5L x 24 tires .....	2 067 mm (81.4 inches)
	17.5L x 24 tires .....	2 074 mm (81.7 inches)
	Ground clearance at backhoe frame .....	375 mm (14.8 inches)

**NOTE:** Specifications on 2 wheel drive machines are measured with 11L x 16 front tires and 19.5L x 24 rear tires. Specifications on 4 wheel drive machines are measured with 12 x 16.5 front tires and 19.5L x 24 rear tires.

### LOADER OPERATING DATA AND DIMENSIONS - 580L

#### 2 083 mm (82 Inch) Standard Bucket

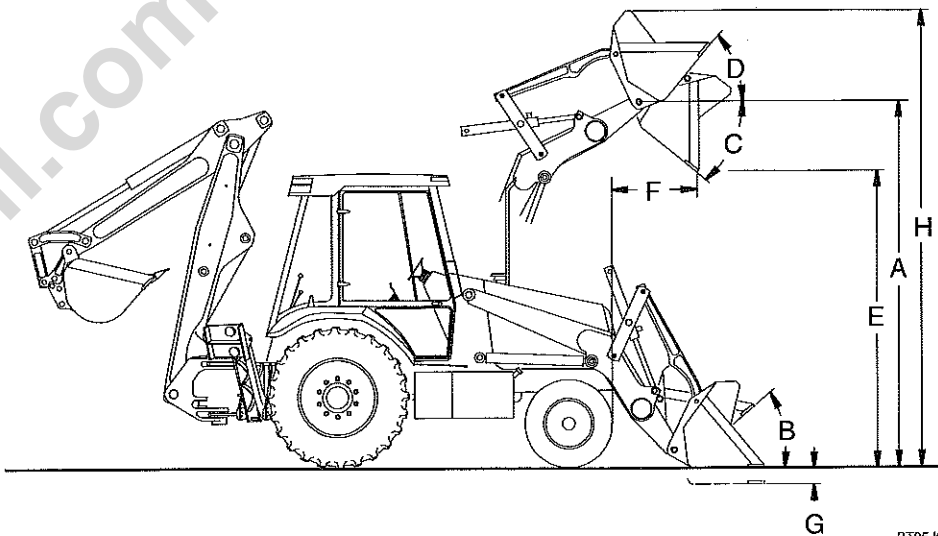

BT95J023

	Lift capacity to full height .....	2 401 kg (5 293 pounds)
A	Height to bucket hinge pin - raised	
	2 Wheel drive .....	3.40 m (11 ft 2.4 in)
	4 Wheel drive .....	3.39 m (11 ft 2 in)
B	Bucket rollback at groundline .....	40°
C	Dump angle at full height .....	46°
D	Rollback at full height .....	Adjustable
	Maximum grading angle .....	116°
E	Dump clearance at full height - 45° dump	
	2 Wheel drive .....	2.64 m (8 ft 8 in)
	4 Wheel drive .....	2.63 m (8 ft 7.7 in)
F	Dump reach at full height - 45° dump .....	660 mm (26 inches)
G	Digging depth below ground line with bucket flat	
	2 Wheel drive .....	191 mm (7.5 inches)
	4 Wheel drive .....	199 mm (7.8 inches)
H	Overall height	
	2 Wheel drive .....	4.16 m (13 ft 8 in)
	4 Wheel drive .....	4.17 m (13 ft 8.2 in)

## LOADER OPERATING DATA AND DIMENSIONS - 580L

2 083 mm (82 Inch) 4-in-1 Bucket

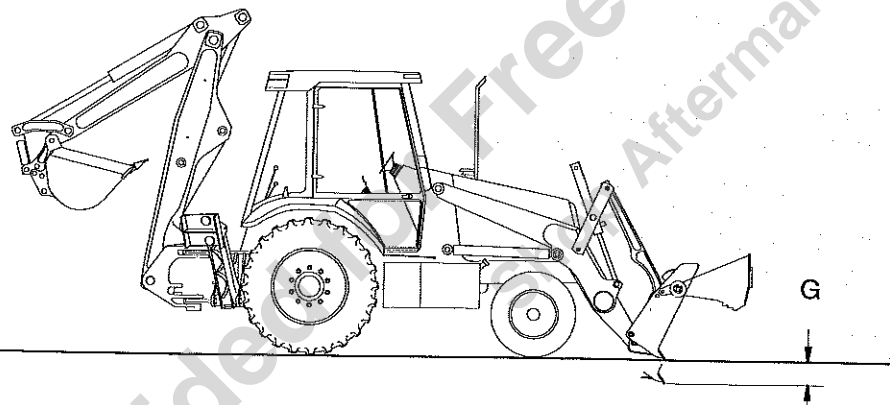
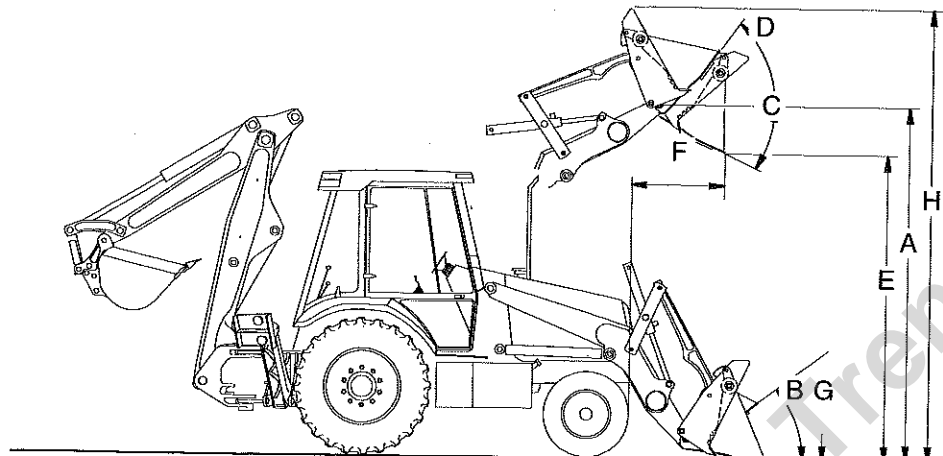

BT95J024

Lift capacity to full height .....	2 357 kg (5 197 pounds)
A Height to bucket hinge pin - raised	
2 Wheel drive .....	3.40 m (11 ft 2.4 in)
4 Wheel drive .....	3.39 m (11 ft 2 in)
B Bucket rollback at groundline .....	40°
C Dump angle at full height .....	45°
D Rollback at full height .....	Adjustable
Maximum grading angle .....	116°
E Dump clearance at full height - 45° dump	
2 Wheel drive	
Clam open .....	2.94 m (9 ft 7.8 in)
Clam closed .....	2.72 m (8 ft 11.1 in)
4 Wheel drive	
Clam open .....	2.93 m (9 ft 7.5 in)
Clam closed .....	2.71 m (8 ft 10.8 in)
F Dump reach at full height - 45° dump	
Clam open .....	302 mm (11.9 inches)
Clam closed .....	647 mm (25.5 inches)
G Digging depth below ground line with bucket flat	
2 Wheel drive .....	172 mm (6.8 inches)
4 Wheel drive .....	180 mm (7.1 inches)
Dozing depth	
2 Wheel drive .....	103 mm (4.1 inches)
4 Wheel drive .....	111 mm (4.4 inches)
H Overall height	
2 Wheel drive .....	4.35 m (14 ft 3.3 in)
4 Wheel drive .....	4.35 m (14 ft 3.4 in)

## BACKHOE OPERATING DATA AND DIMENSIONS - 580L

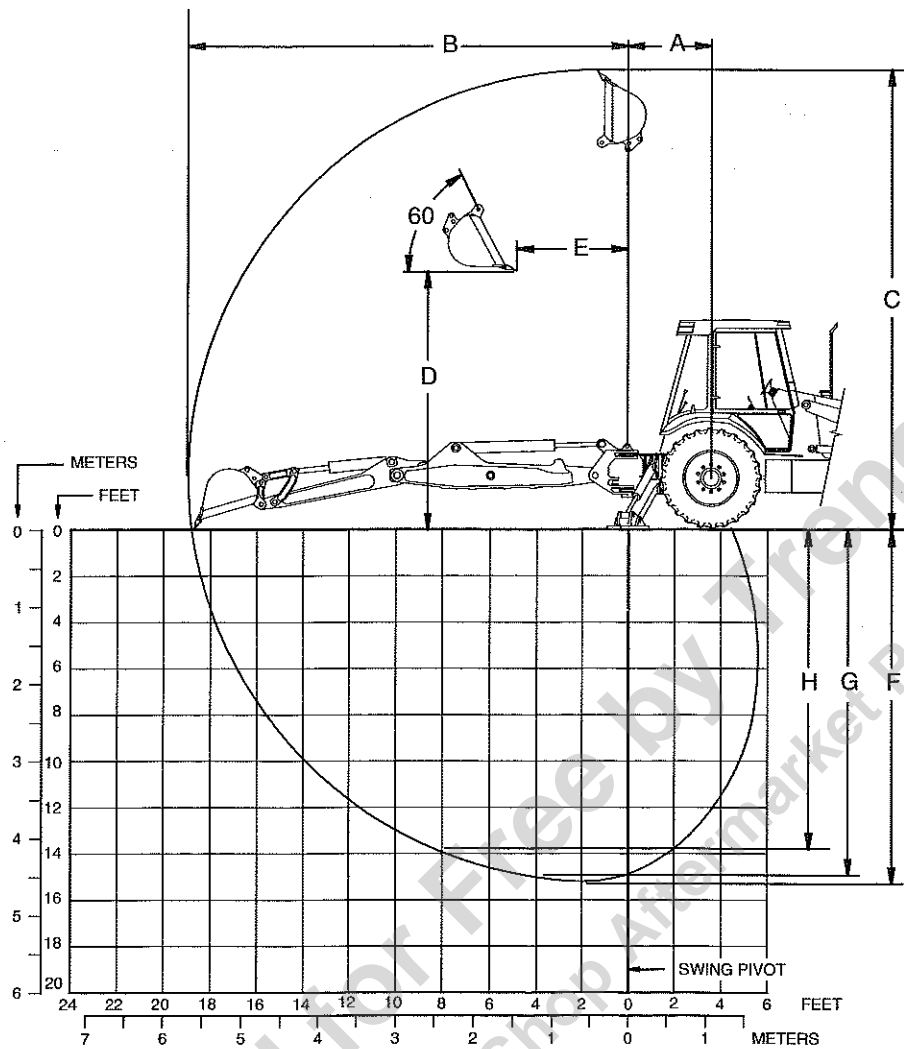

BT95J098

**NOTE:** Specifications taken with 2 wheel drive, 610 mm (24 inch) general purpose backhoe bucket, 19.5L x 24 rear tires.

A	Swing pivot to rear axle centerline .....	1.10 m (3 ft 7.3 in)
B	Digging radius from swing pivot .....	5.44 m (17 ft 10 in)
C	Maximum height .....	5.85 m (19 ft 2.1 in)
D	Loading height .....	3.39 m (*11 ft 1.6 in)
		3.12 m (10 ft 2.8 in)
E	Loading reach .....	2.66 m (*8 ft 8.6 in)
		1.78 m (5 ft 10.1 in)
F	Dig depth .....	4.36 m (14 ft 3.5 in)
G	Dig depth, 610 mm (2 ft) flat bottom trench .....	4.31 m (14 ft 1.8 in)
H	Dig depth, 2.4 m (8 ft) flat bottom trench .....	4.03 m (13 ft 2.4 in)

\* Maximum height and maximum reach are not obtainable at the same time and the same backhoe position.

### BACKHOE LIFT CAPACITY - 580L

#### Boom and Dipper Lift

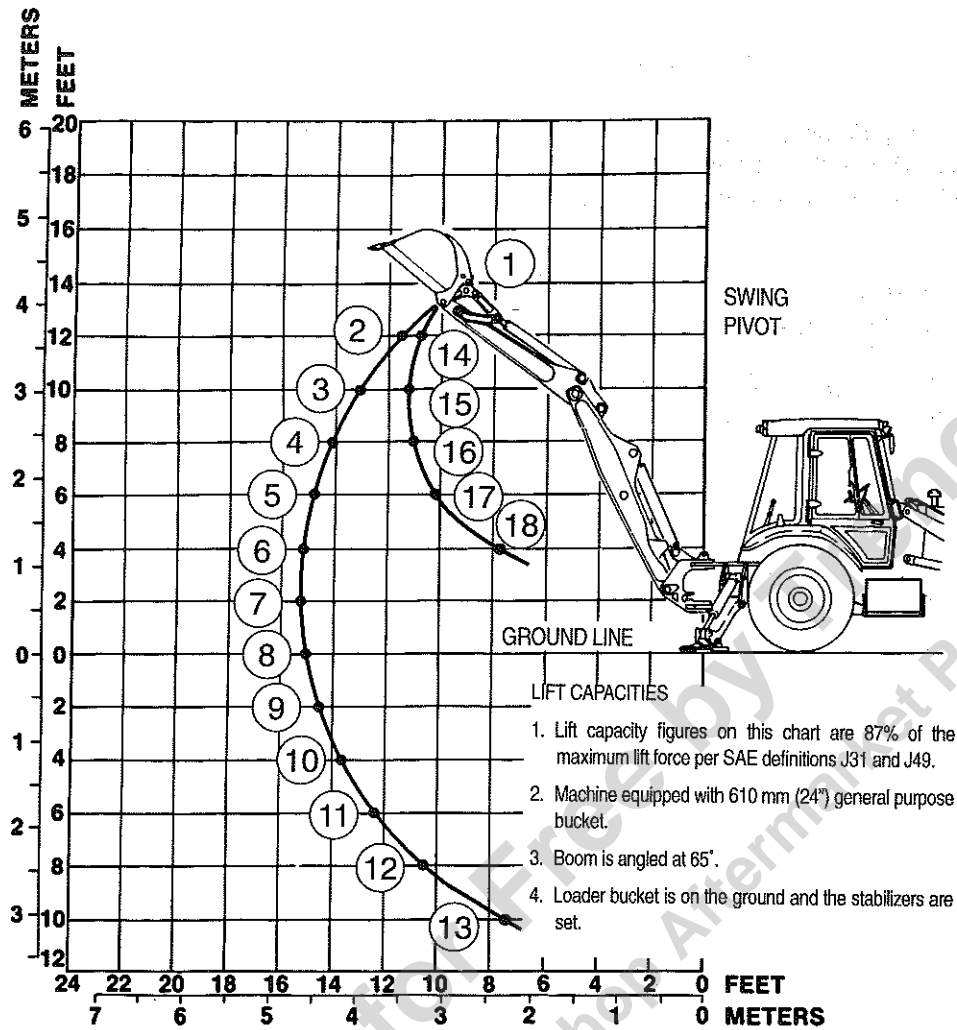

B902731J

#### Backhoe Straight to Rear

	kg (Pounds)		kg (Pounds)
1.	885 (1 951)	10.	1 107 (2 442)
2.	1 225 (2 701)	11.	1 106 (2 439)
3.	1 223 (2 697)	12.	1 135 (2 504)
4.	1 249 (2 754)	13.	1 260 (2 778)
5.	1 237 (2 727)	14.	1 791 (3 950)
6.	1 233 (2 719)	15.	1 673 (3 689)
7.	1 216 (2 682)	16.	1 698 (3 745)
8.	1 127 (2 486)	17.	1 859 (4 100)
9.	1 105 (2 436)	18.	2 135 (4 709)

#### Backhoe within Swing Arc

	kg (Pounds)		kg (Pounds)
1.	894 (1 971)	14.	1 909 (4 209)
2.	1 191 (2 626)	15.	1 714 (3 780)
3.	1 260 (2 780)	16.	1 813 (3 999)
4.	1 254 (2 765)	17.	2 084 (4 597)
5.	1 267 (2 795)	18.	2 493 (5 498)
6.	1 237 (2 727)		
7.	1 213 (2 675)		

## BACKHOE LIFT CAPACITY - 580L (2WD)

### Dipper Lift

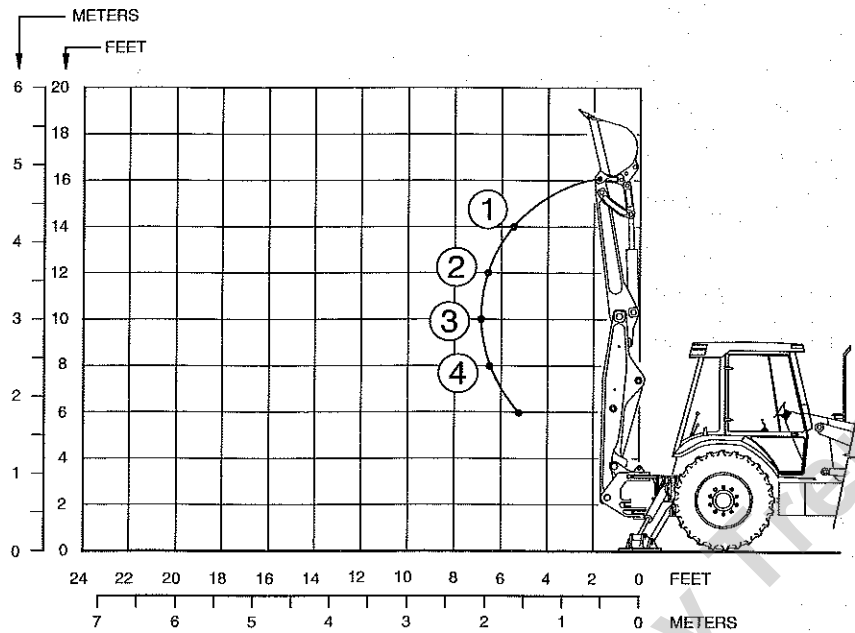

### LIFT CAPACITIES

1. Lift capacity figures on this chart are 87% of the maximum lift force per SAE J31 and J49.
2. Machine equipped with 610 mm (24 in) general purpose bucket.
3. Boom is latched in transport position.
4. Loader bucket is on the ground and the stabilizers are set.
5. System relief pressure is at 207 bars (3 000 psi).

BT96H168

### Backhoe Straight to Rear

	kg	(Pounds)
1.	3 487	(7 691)
2.	2 481	(5 472)
3.	1 955	(4 311)
4.	1 528	(3 370)

### Backhoe within Swing Arc

	kg	(Pounds)
1.	3 695	(8 149)
2.	2 482	(5 474)
3.	1 990	(4 389)
4.	1 709	(3 770)

# EXTENDAHOE OPERATING DATA AND DIMENSIONS - 580L

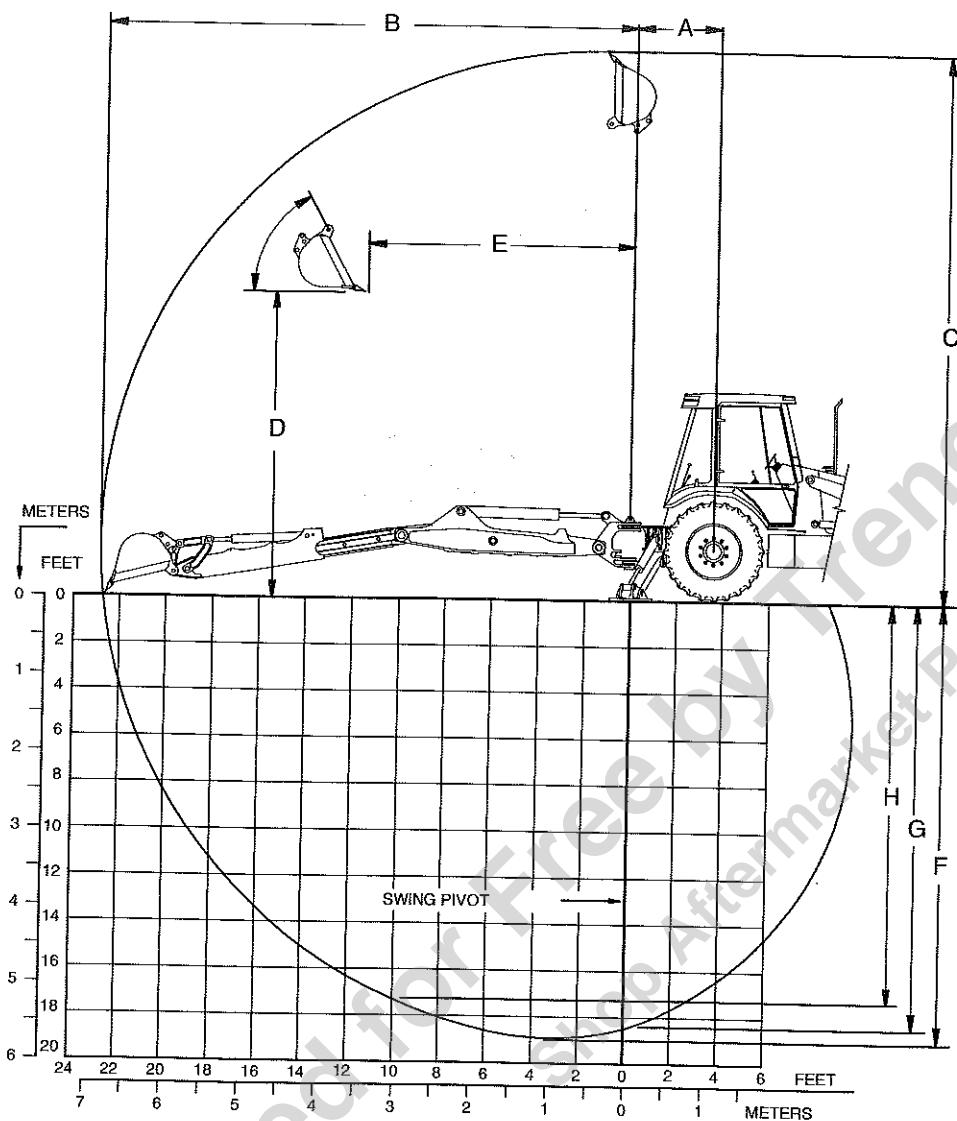

BT95J097

**NOTE:** Specifications with 610 mm (24 inch) universal heavy duty trenching bucket, 19.5L x 24 rear tires.

	Retracted	Extended
A. Swing pivot to rear axle centerline .....	1.10 m (3 ft 7.3 in)	1.10 m (3 ft 7.3 in)
B. Digging radius from swing pivot ....	5.21 m (18 ft 4.6 in)	6.66 m (21 ft 10 in)
C. Maximum height.....	5.94 m (19 ft 5.9 in)	6.97 m (22 ft 10.2 in)
D. Loading height .....	3.47 m (*11 ft 4.6 in)	4.03 m (*13 ft 2.5 in)
E. Loading reach .....	3.28 m (10 ft 9 in)	3.88 m (12 ft 8.8 in)
F. Digging Depth .....	2.63 m (*8 ft 7.7 in)	3.50 m (*11 ft 5.6 in)
G. Digging depth, 610 mm (2 ft) level bottom .....	1.97 m (6 ft 5.5 in)	2.93 m (9 ft 7.5 in)
H. Digging Depth, 2.4 m (8 ft) level bottom .....	4.51 m (14 ft 9.6 in)	5.57 m (18 ft 3.3 in)
	4.47 m (14 ft 8.1 in)	5.54m (18 ft 2.5 in)
	4.20 m (13 ft 9.2 in)	5.33 m (17 ft 5.7 in)

\* Maximum height and maximum reach are not obtainable at the same time and the same backhoe position.

## EXTENDAHOE LIFT CAPACITY - RETRACTED 580L

### Boom and Dipper Lift

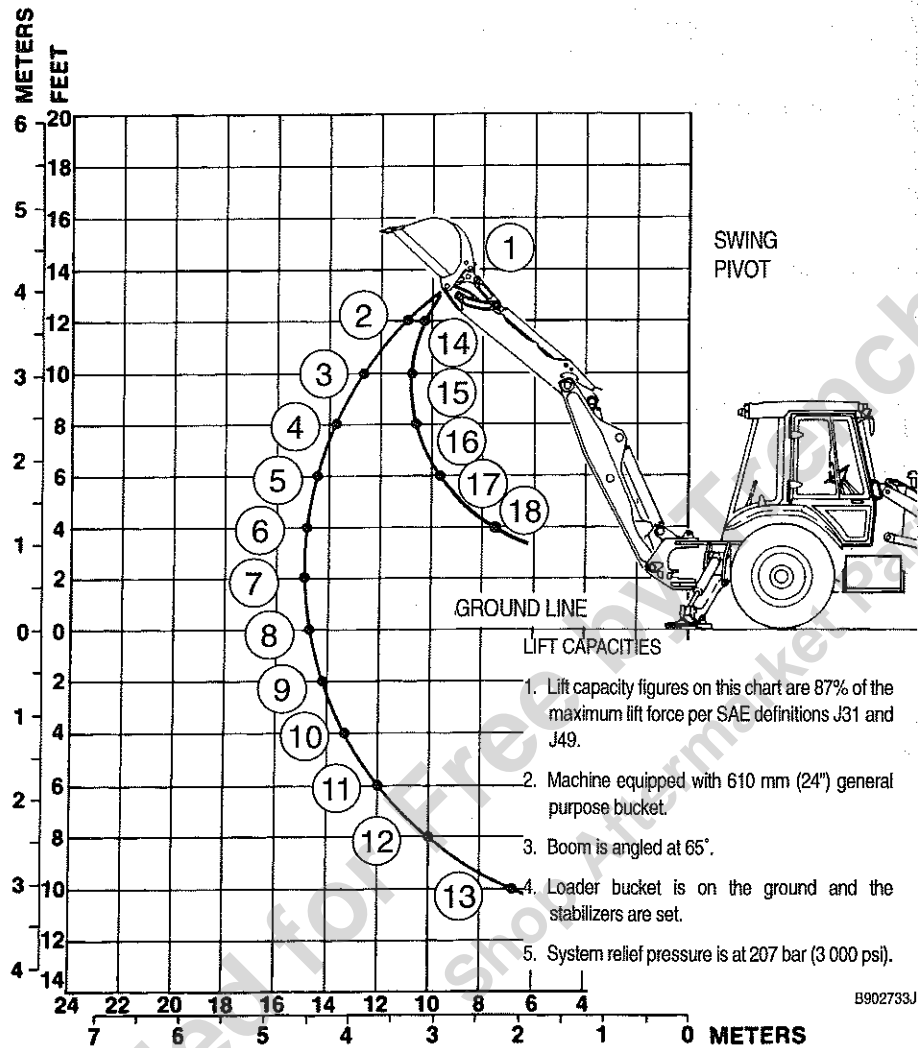

### Backhoe Straight to Rear

kg (Pounds)		kg (Pounds)	
1.	581 (1 282)	10.	1 015 (2 238)
2.	880 (1 940)	11.	1 029 (2 270)
3.	998 (2 201)	12.	1 067 (2 352)
4.	1 005 (2 217)	13.	1 178 (2 598)
5.	1 026 (2 262)	14.	1 555 (3 430)
6.	1 039 (2 291)	15.	1 438 (3 171)
7.	1 039 (2 291)	16.	1 468 (3 238)
8.	1 030 (2 272)	17.	1 636 (3 609)
9.	1 023 (2 255)	18.	1 947 (4 293)

### Backhoe within Swing Arc

kg (Pounds)		kg (Pounds)	
1.	538 (1 188)	14.	1 626 (3 587)
2.	857 (1 891)	15.	1 497 (3 302)
3.	980 (2 162)	16.	1 588 (3 502)
4.	1 024 (2 258)	17.	1 667 (3 676)
5.	1 045 (2 306)	18.	1 983 (4 373)
6.	1 063 (2 345)		
7.	1 057 (2 332)		

## EXTENDAHOE LIFT CAPACITY - EXTENDED 580L

### Boom and Dipper Lift

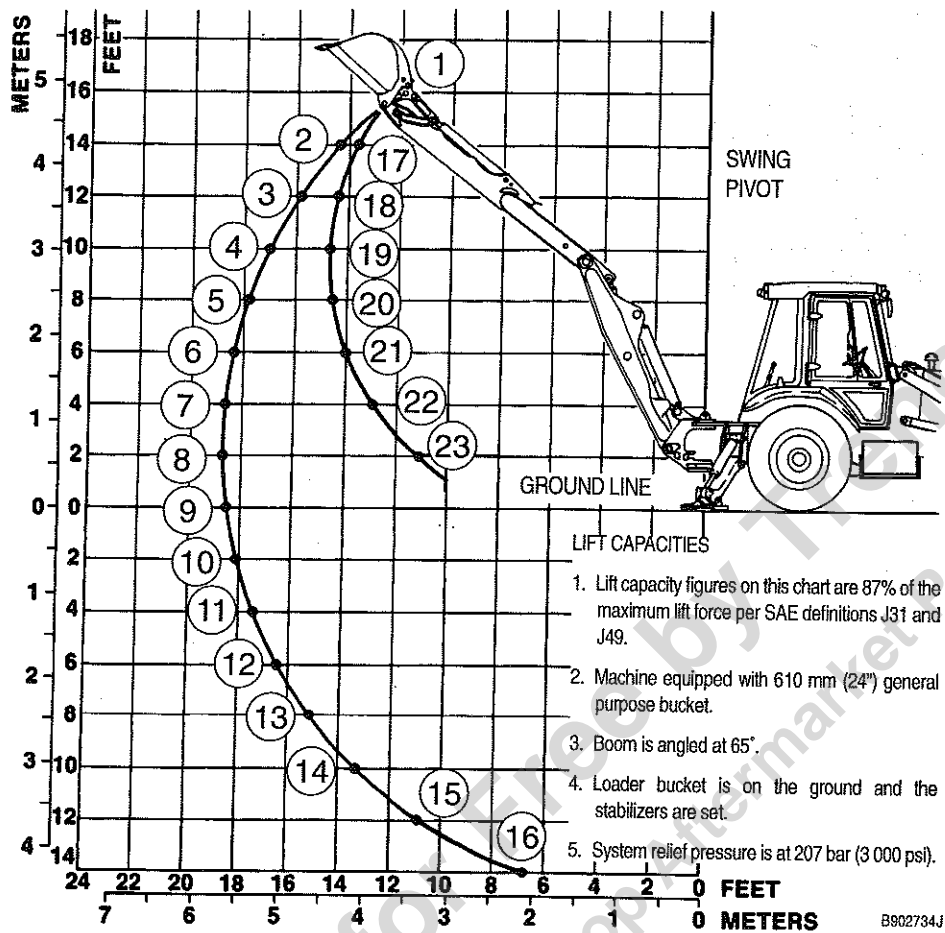

### Backhoe Straight to Rear

	kg (Pounds)		kg (Pounds)
1.	367 (804)	13.	806 (1 778)
2.	635 (1 401)	14.	850 (1 874)
3.	646 (1 425)	15.	925 (2 039)
4.	700 (1 544)	16.	1 185 (2 613)
5.	730 (1 610)	17.	959 (2 116)
6.	733 (1 616)	18.	1 001 (2 208)
7.	753 (1 662)	19.	999 (2 203)
8.	770 (1 699)	20.	980 (2 160)
9.	782 (1 725)	21.	1 013 (2 234)
10.	779 (1 718)	22.	1 097 (2 419)
11.	783 (1 727)	23.	1 257 (2 771)
12.	789 (1 741)		

### Backhoe within Swing Arc

	kg (Pounds)		kg (Pounds)
1.	384 (847)	17.	1 019 (2 247)
2.	588 (1 296)	18.	1 041 (2 295)
3.	636 (1 403)	19.	1 018 (2 245)
4.	701 (1 547)	20.	1 030 (2 272)
5.	708 (1 562)	21.	1 045 (2 304)
6.	753 (1 662)	22.	1 140 (2 514)
7.	774 (1 708)	23.	1 318 (2 908)
8.	803 (1 770)		

## EXTENDAHOE LIFT CAPACITY - 580L (2WD)

### Extendable Dipper Lift (Retracted)

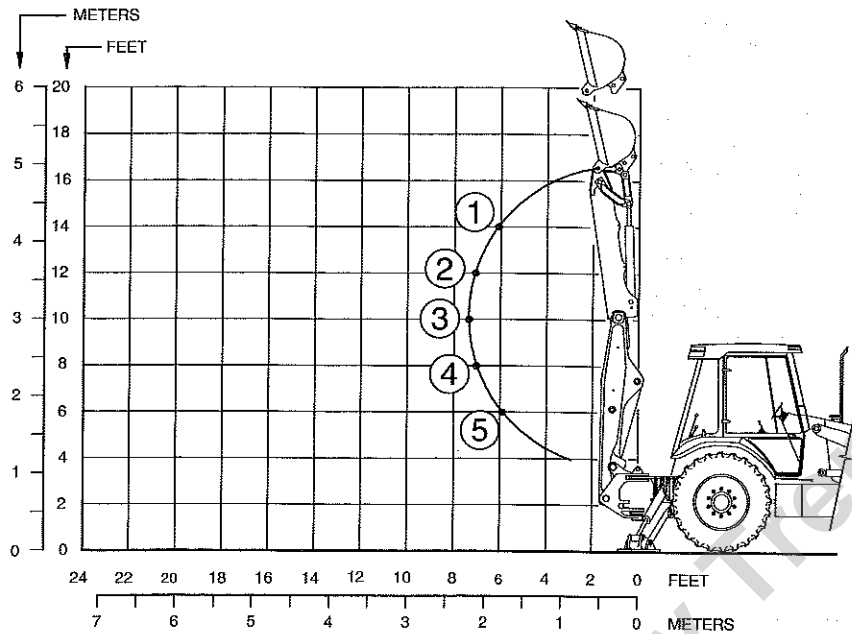

#### LIFT CAPACITIES

1. Lift capacity figures on this chart are 87% of the maximum lift force per SAE J31 and J49.
2. Machine equipped with 610 mm (24 in) general purpose bucket.
3. Boom is latched in transport position.
4. Loader bucket is on the ground and the stabilizers are set.
5. System relief pressure is at 207 bars (3 000 psi).

### Backhoe Straight to Rear

	kg	(Pounds)
1.	2 833	(6 247)
2.	2 300	(5 072)
3.	1 919	(4 233)
4.	1 598	(3 524)
5.	1 323	(2 917)

### Backhoe within Swing Arc

	kg	(Pounds)
1.	2 677	(5 904)
2.	2 243	(4 947)
3.	1 884	(4 154)
4.	1 591	(3 508)
5.	NA	NA

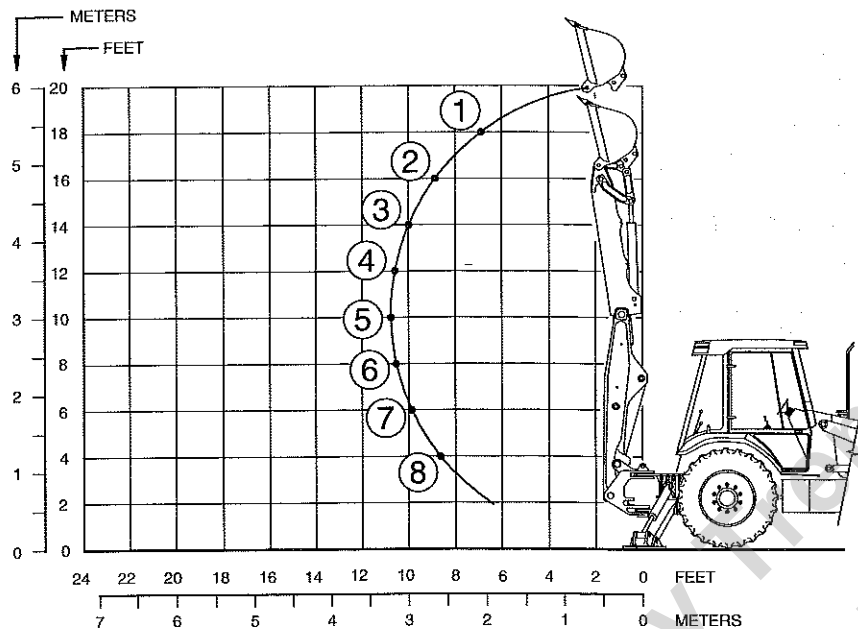
**EXTENDAHOE LIFT CAPACITY - 580L (2WD)****Extendable Dipper Lift (Extended)****LIFT CAPACITIES**

1. Lift capacity figures on this chart are 87% of the maximum lift force per SAE J31 and J49.
2. Machine equipped with 610 mm (24 in) general purpose bucket.
3. Boom is latched in transport position.
4. Loader bucket is on the ground and the stabilizers are set.
5. System relief pressure is at 207 bars (3 000 psi).

**Backhoe Straight to Rear**

	kg	(Pounds)
1.	NA	NA
2.	1 672	(3 687)
3.	1 414	(3 119)
4.	1 252	(2 762)
5.	1 131	(2 495)
6.	987	(2 178)
7.	873	(1 925)
8.	750	(1 653)
9.	686	(1 514)

**Backhoe within Swing Arc**

	kg	(Pounds)
1.	2 029	(4 475)
2.	1 658	(3 656)
3.	1 416	(3 123)
4.	1 251	(2 759)
5.	1 110	(2 449)
6.	993	(2 189)
7.	875	(1 931)
8.	749	(1 651)
9.	NA	NA

This page left blank.

## SPECIFICATIONS - 580 SUPER L

### ENGINE DATA - 580 SUPER L

Make and model .....	Case 4T-390
Firing order .....	1-3-4-2
Air induction .....	Turbocharged
Bore and stroke .....	102 x 120 mm (4.02 x 4.72 inches)
Displacement .....	3.92 litres (239 cu in)
Compression ratio .....	17.5 to 1
Fuel .....	See page 146
Horsepower - rated	
SAE net .....	64 kW at 2 200 r/min (86 at 2 200 rpm)
SAE gross .....	68 kW at 2 200 r/min (91 at 2 200 rpm)
Engine speeds	
Full throttle - no load .....	2 325 to 2 425 rpm
Full throttle - full load .....	2 200 rpm
Idle speed .....	900 to 975 rpm
Loader hydraulic stall .....	2 150 to 2 390 rpm
Torque converter stall .....	2 030 to 2 250 rpm
Combined stall .....	1 480 to 1 650 rpm
Backhoe hydraulic stall .....	2 100 to 2 300 rpm
Valve clearance - engine cold	
Intake valves .....	0.254 mm (0.010 inch)
Exhaust valves .....	0.508 mm (0.020 inch)

### BOLT TORQUES

Front wheel mounting bolts (2 wheel drive) .....	156 to 203 Nm (115 to 150 pound-feet)
Front wheel mounting nuts (4 wheel drive) .....	270 to 352 Nm (200 to 260 pound-feet)
Rear wheel mounting nuts .....	129 to 136 Nm (95 to 100 pound-feet)

Then turn in the tightening direction an additional 55 to 65 degrees. This applies to the rear wheel nuts only.

### MAIN RELIEF VALVE PRESSURES - 580 SUPER L

Loader and backhoe .....	207 + 7 - 0 bar (3 000 + 100 - 0 psi)
--------------------------	--

(The loader control valve controls the loader and backhoe hydraulic pressure.)

**TRAVEL SPEEDS - 580 SUPER L**

Measured with 19.5L x 24 Tires

	1st km/h (mph)	2nd km/h (mph)	3rd km/h (mph)	4th km/h (mph)
Forward	5.98 (3.72)	10.80 (6.71)	20.78 (12.91)	41.56 (25.83)
Reverse	7.22 (4.48)	13.02 (8.09)	25.01 (15.54)	49.97 (31.05)

**NOTE:** (Travel speeds measured at 2 353 engine rpm with zero torque converter slip)

**OPERATING WEIGHTS - 580 SUPER L****Lightest Configuration**

2 083 mm (82 inch) standard bucket, 2WD, 17.5L x 24 rear tires, 11L x 16 front tires, no front counterweight, standard dipper, cast stabilizer pads, non-suspension seat, ROPS canopy, single battery, no operator..... 6 025 kg (13 283 pounds)

**Heaviest Configuration**

2 083 mm (82 inch) 4-in-1 bucket, 4WD, 19.5L x 24 rear tires, 12 x 16.5 front tires, 225 kg (500 pound) front counterweight, extendahoe, 610 mm (24 inch) HD bucket, flip over stabilizer pads, suspension seat, ROPS Cab, Air Conditioner, Dual Batteries, no operator, and mechanical front wheel drive guard ..... 7 151 kg (15 764 pounds)

**LOADER BUCKETS - 580 SUPER L**

Width mm (Inch)	Type	Capacities SAE Heaped m <sup>3</sup> (cu yds)	Capacities Struck m <sup>3</sup> (cu yds)	Weight kg (lbs)
2 083 (82)	Long Lip	0.77 (1.01)	0.68 (0.88)	392 (864)
2 083 (82)	4-in-1	0.79 (1.04)	0.65 (0.85)	663 (1 462)

**BACKHOE BUCKETS - 580 SUPER L**

Width mm (Inch)	Type	Capacities SAE Heaped m <sup>3</sup> (cu feet)	Capacities Struck m <sup>3</sup> (cu foot)	Weight kg (lbs)
305 (12)	Universal HD	0.068 (2.41)	0.082 (2.90)	141 (311)
406 (16)	Universal HD	0.083 (2.92)	0.101 (3.60)	157 (346)
457 (18)	Universal HD	0.094 (3.33)	0.122 (4.30)	163 (359)
610 (24)	Universal HD	0.135 (4.78)	0.181 (6.40)	195 (429)
762 (30)	Universal HD	0.176 (6.22)	0.245 (8.65)	225 (496)
914 (36)	Universal HD	0.217 (7.67)	0.306 (10.80)	259 (571)
610 (24)	High Capacity HD	0.241 (8.50)	0.195 (6.90)	195 (430)
762 (30)	High capacity HD	0.300 (10.6)	0.243 (8.60)	203 (447)

**BASIC MACHINE DIMENSIONS - 580 SUPER L**

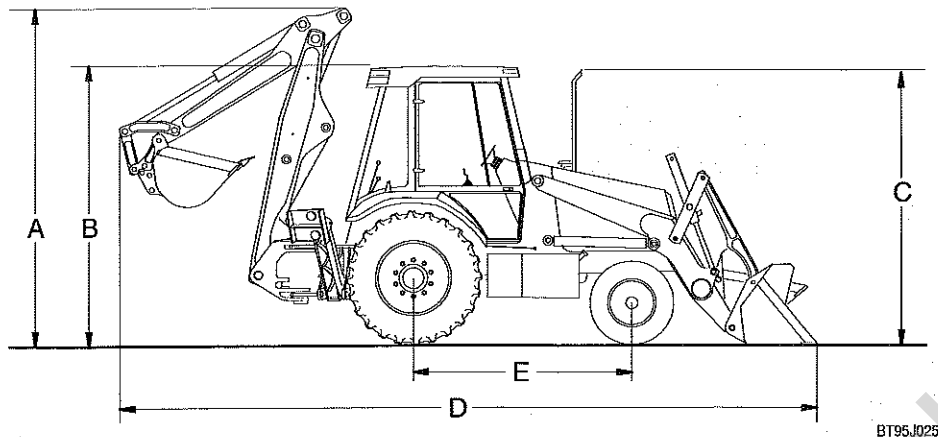

BT95J025

- A Overall height - backhoe in transport position
  - 2 Wheel drive ..... 3.30 m (10 ft 10 in)
  - 4 Wheel drive ..... 3.30 m (10 ft 9.7 in)
- B Height to top of ROPS canopy
  - 2 Wheel drive ..... 2.67 m (8 ft 9.2 in)
  - 4 Wheel drive ..... 2.67 m (8 ft 9.1 in)
- B Height to top of ROPS cab
  - 2 Wheel drive ..... 2.72 m (8 ft 11.1 in)
  - 4 Wheel drive ..... 2.72 m (8 ft 11 in)
- C Height to top of exhaust stack
  - 2 Wheel drive ..... 2.64 m (8 ft 7.9 in)
  - 4 Wheel drive ..... 2.63 m (8 ft 7.5 in)
- D Overall length - backhoe in transport position, loader bucket on the ground
  - 2 083 mm (82 inch) standard bucket ..... 6.92 m (22 ft 8.5 in)
  - 2 083 mm (82 inch) 4-in-1 bucket ..... 6.89 m (22 ft 7.2 in)
- E Wheel base
  - 2 Wheel drive ..... 2 134 mm (84.0 inches)
  - 4 Wheel drive ..... 2 146 mm (84.5 inches)
- Width over tires
  - 11L x 16 tires ..... 2 009 mm (79.1 inches)
  - 12 x 16.5 tires ..... 2 060 mm (81.1 inches)
  - 19.5L x 24 tires ..... 2 077 mm (81.8 inches)
  - 17.5L x 24 tires ..... 2 077 mm (81.8 inches)
  - 16.9 x 24 tires ..... 2 077 mm (81.8 inches)
- Ground clearance at the backhoe frame ..... 375 mm (14.8 inches)

**NOTE:** Specifications on 2 wheel drive machines are measured with 11L x 16 front tires and 19.5L x 24 rear tires. Specifications on 4 wheel drive machines are measured with 12 x 16.5 front tires and 19.5L x 24 rear tires.

**LOADER OPERATING DATA AND DIMENSIONS - 580 SUPER L**

**2 083 mm (82 Inch) Standard Bucket**

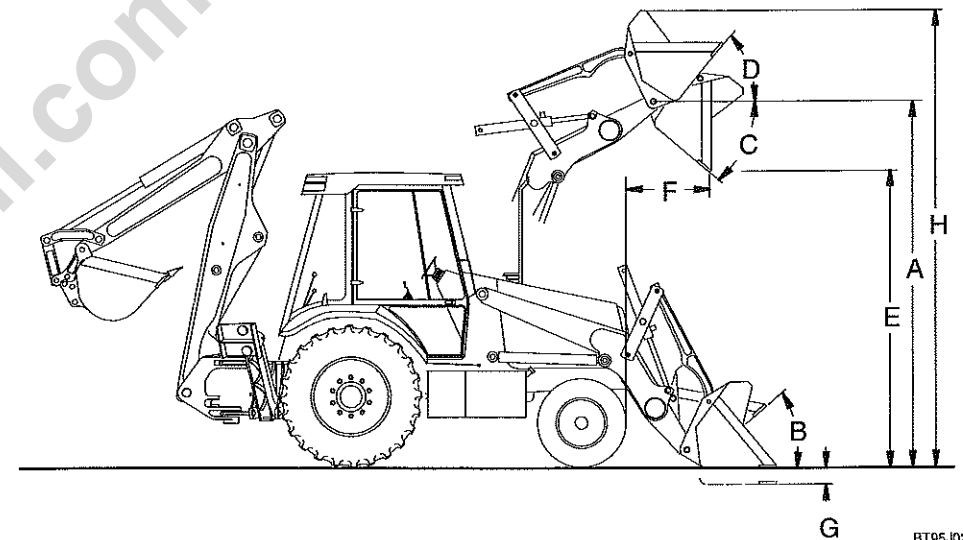

BT95J023

- Lift capacity to full height ..... 2 937 kg (6 474 pounds)
- A Height to bucket hinge pin - raised
  - 2 Wheel drive ..... 3.41 m (11 ft 2.4 in)
  - 4 Wheel drive ..... 3.41 m (11 ft 2 in)
- B Bucket rollback at groundline ..... 40°
- C Dump angle at full height ..... 45°
- D Rollback at full height ..... Adjustable
- Maximum grading angle ..... 116°
- E Dump clearance at full height - 45° dump
  - 2 Wheel drive ..... 2.69 m (8 ft 9.8 in)
  - 4 Wheel drive ..... 2.68 m (8 ft 9.5 in)
- F Dump reach at full height - 45° dump ..... 703 mm (27.7 inches)
- G Digging depth below ground line with bucket flat
  - 2 Wheel drive ..... 149 mm (5.9 inches)
  - 4 Wheel drive ..... 157 mm (6.2 inches)
- H Overall height
  - 2 Wheel drive ..... 4.26 m (13 ft 11.5 in)
  - 4 Wheel drive ..... 4.26 m (13 ft 11.6 in)

## LOADER OPERATING DATA AND DIMENSIONS - 580 SUPER L

2 083 mm (82 Inch) 4-in-1 Bucket

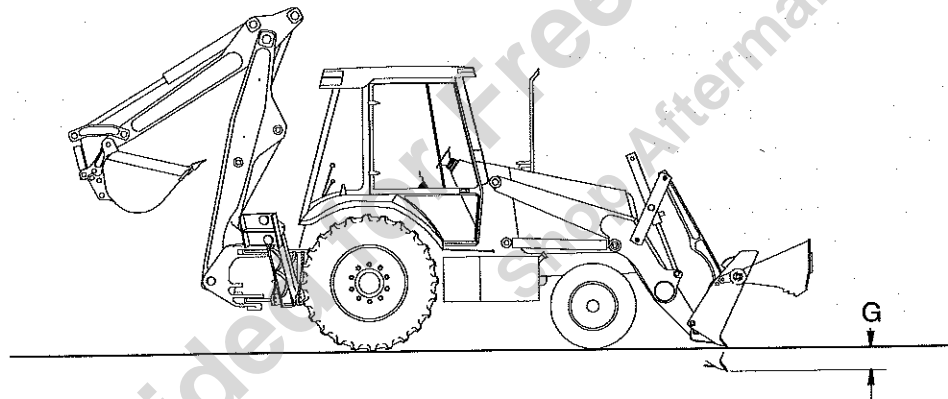
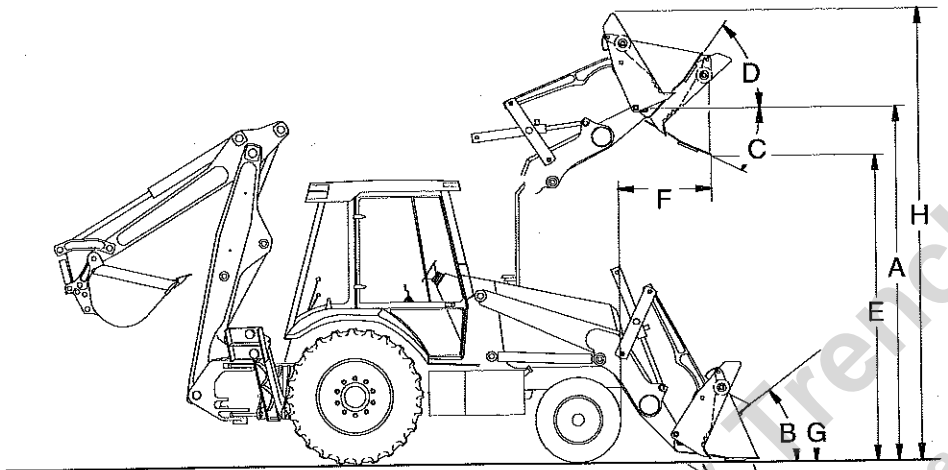

BT95J024

	Lift capacity to full height .....	2 501 kg (5 514 pounds)
A	Height to bucket hinge pin - raised	
	2 Wheel drive .....	3.41 m (11 ft 2.4 in)
	4 Wheel drive .....	3.41 m (11 ft 2 in)
B	Bucket rollback at groundline .....	40°
C	Dump angle at full height .....	45°
D	Rollback at full height .....	Adjustable
	Maximum grading angle .....	116°
E	Dump clearance at full height - 45° dump	
	2 Wheel drive	
	Clam open .....	2.94 m (9 ft 7.8 in)
	Clam closed .....	2.72 m (8 ft 11.1 in)
	4 Wheel drive	
	Clam open .....	2.93 m (9 ft 7.5 in)
	Clam closed .....	2.71 m (8 ft 10.8 in)
F	Dump reach at full height - 45° dump	
	Clam open .....	302 mm (11.9 inches)
	Clam closed .....	647 mm (25.5 inches)
G	Digging depth below ground line with bucket flat	
	2 Wheel drive .....	172 mm (6.8 inches)
	4 Wheel drive .....	180 mm (7.1 inches)
	Dozing depth	
	2 Wheel drive .....	103 mm (4.1 inches)
	4 Wheel drive .....	111 mm (4.4 inches)
H	Overall height	
	2 Wheel drive .....	4.35 m (14 ft 3.3 in)
	4 Wheel drive .....	4.35 m (14 ft 3.4 in)

## BACKHOE OPERATING DATA AND DIMENSIONS - 580 SUPER L

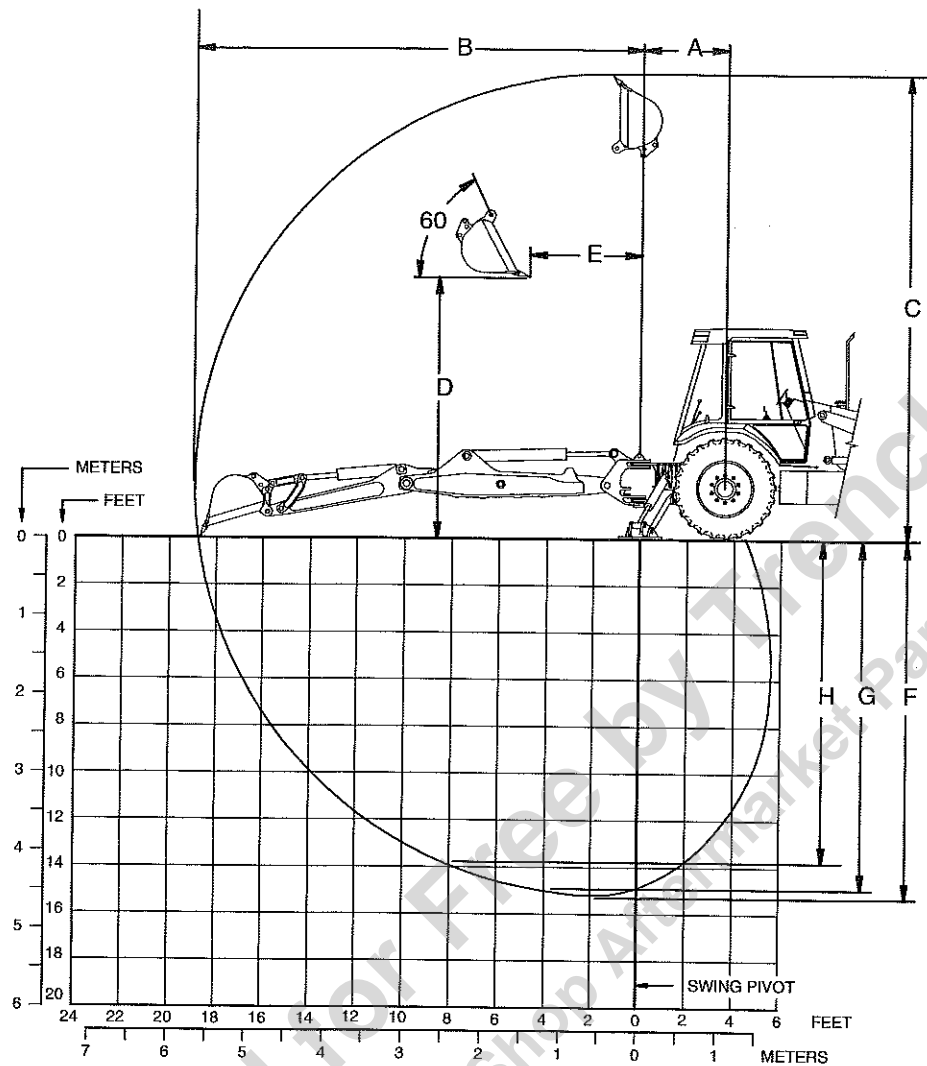

BT95J098

**NOTE:** Specifications taken with 2 wheel drive, 610 mm (24 inch) universal HD backhoe bucket, 19.5L x 24 rear tires.

A	Swing pivot to rear axle centerline .....	1.10 m (3 ft 7.3 in)
B	Digging radius from swing pivot .....	5.50 m (18 ft 0.6 in)
C	Maximum height .....	5.85 m (19 ft 2.1 in)
D	Loading height .....	3.39 m (*11 ft 1.6 in)
		3.12 m (10 ft 2.8 in)
E	Loading reach .....	2.66 m (*8 ft 8.6 in)
		1.78 m (5 ft 10.1 in)
F	Dig depth .....	4.39 m (14 ft 4.8 in)
G	Dig depth, 610 mm (2 ft) flat bottom trench .....	4.35 m (14 ft 3.1 in)
H	Dig depth, 2.4 m (8 ft) flat bottom trench .....	4.06 m (13 ft 3.7 in)

\* Maximum height and maximum reach are not obtainable at the same time and the same backhoe position.

# BACKHOE LIFT CAPACITY - 580 SUPER L

## Boom and Dipper Lift

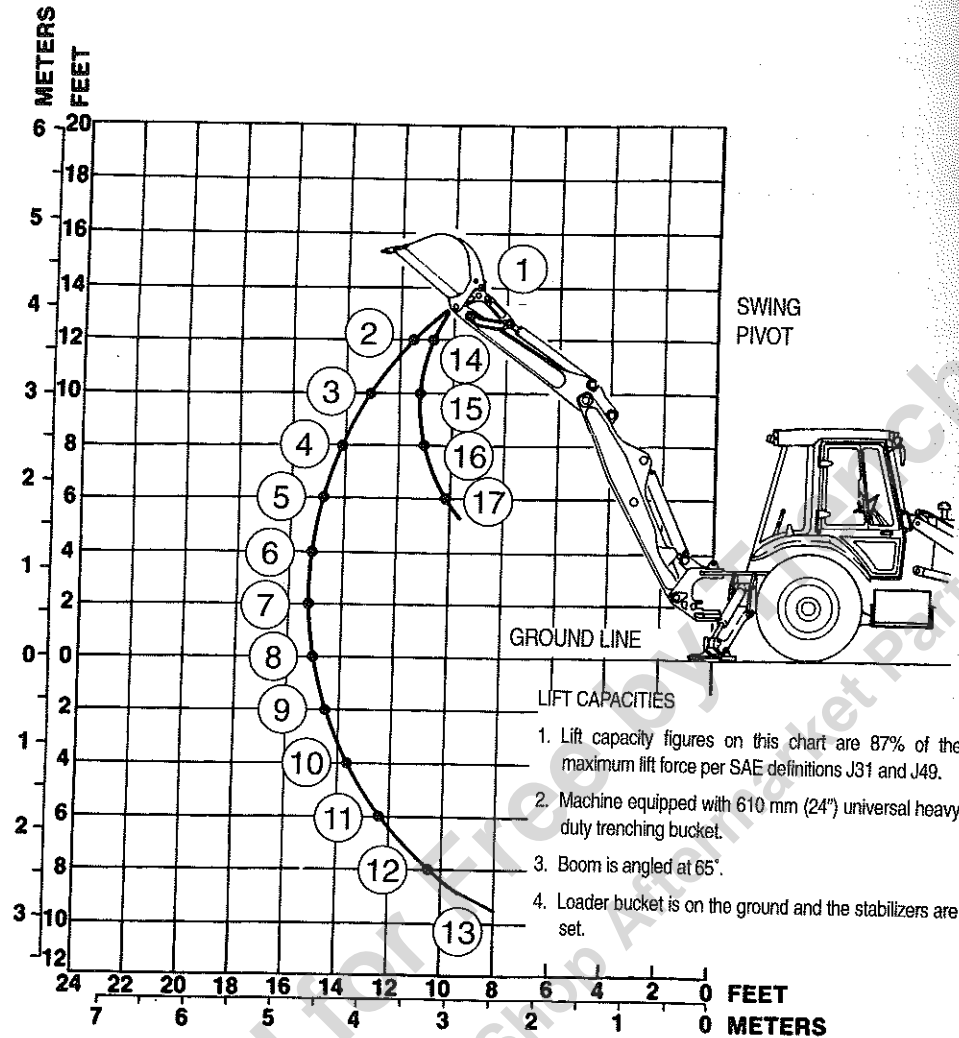

B802731J

## Backhoe Straight to Rear

kg (Pounds)		kg (Pounds)	
1. 1 086	(2 394)	10. 1 149	(2 533)
2. 1 283	(2 829)	11. 1 145	(2 525)
3. 1 314	(2 899)	12. 1 149	(2 533)
4. 1 299	(2 864)	13. 1 243	(2 742)
5. 1 283	(2 829)	14. 2 309	(5 091)
6. 1 259	(2 777)	15. 2 176	(4 800)
7. 1 228	(2 707)	16. 2 188	(4 826)
8. 1 224	(2 699)	17. 2 468	(5 444)
9. 1 184	(2 612)		

## Backhoe within Swing Arc

kg (Pounds)		kg (Pounds)	
1. 1 062	(2 342)	14. 2 316	(5 109)
2. 1 275	(2 812)	15. 2 115	(4 665)
3. 1 314	(2 899)	16. 2 163	(4 769)
4. 1 322	(2 916)	17. 2 399	(5 291)
5. 1 307	(2 881)		
6. 1 291	(2 847)		
7. 1 251	(2 760)		

## BACKHOE LIFT CAPACITY - 580 SUPER L (2WD)

### Dipper Lift

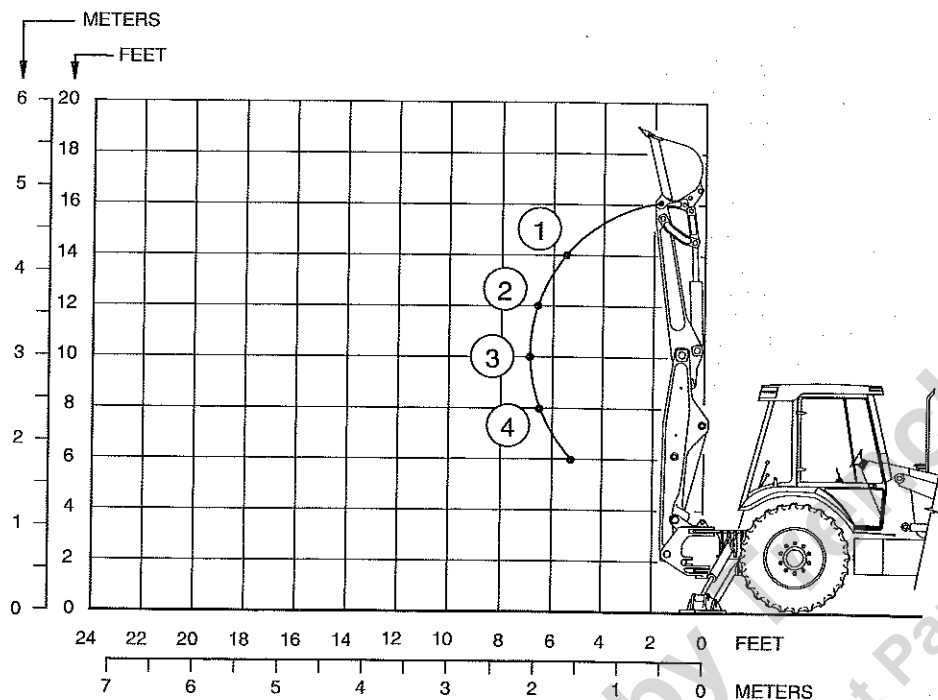

### LIFT CAPACITIES

B9505169T

1. Lift capacity figures on this chart are 87% of the maximum lift force per SAE J31 and J49.
2. Machine equipped with 610 mm (24 in) Universal H.D. bucket.
3. Boom is latched in transport position.
4. Loader bucket is on the ground and the stabilizers are set.
5. System relief pressure is at 207 bars (3 000 psi).

**NOTE:** Lift Capacities may be increased by 68 kg (150 lbs) when the 610 mm (24 in) Standard Trenching Bucket and links are used in place of the 610 mm (24 in) Universal H.D. bucket with Case Coupler.

### Backhoe Straight to Rear

	kg	(Pounds)
1.	3 969	(8 752)
2.	2 951	(6 508)
3.	2 343	(5 168)
4.	1 870	(4 124)

### Backhoe within Swing Arc

	kg	(Pounds)
1.	3 834	(8 456)
2.	2 911	(6 421)
3.	2 375	(5 237)
4.	1 901	(4 193)

**EXTENDAHOE OPERATING DATA AND DIMENSIONS -  
580 SUPER L**

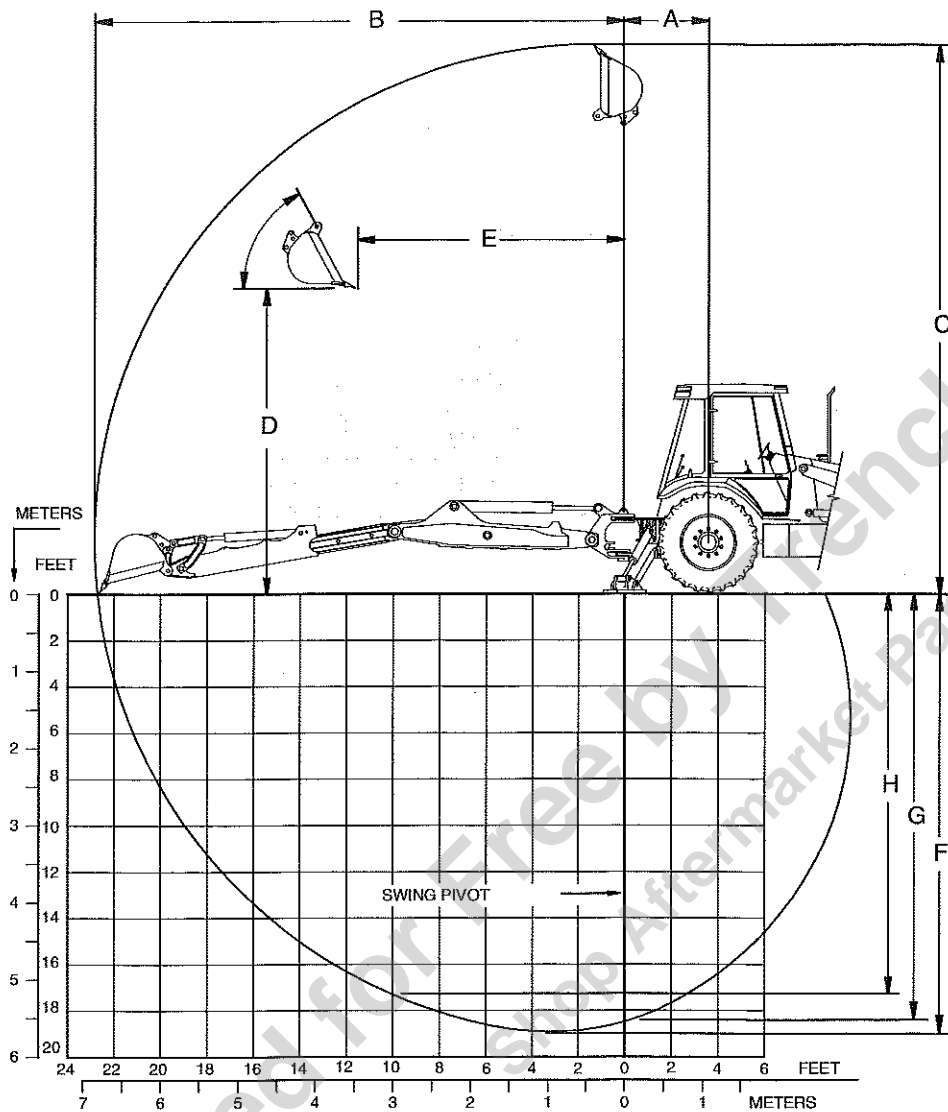

BT95J097

**NOTE:** Specifications with 610 mm (24 inch) universal heavy duty trenching bucket, 19.5L x 24 rear tires.

	Retracted	Extended
A. Swing pivot to rear axle centerline .....	1.10 m (3 ft 7.4 in)	1.10 m (3 ft 7.4 in)
B. Digging radius from swing pivot .....	5.60 m (18 ft 4.6 in)	6.66 m (21 ft 10 in)
C. Maximum height.....	5.94 m (19 ft 5.9 in)	6.97 m (22 ft 10.2 in)
D. Loading height .....	3.47 m (*11 ft 4.6 in)	4.03 m (13 ft 2.5 in)
E. Loading reach .....	3.28 m (10 ft 9 in)	3.88 m (12 ft 8.8 in)
F. Digging depth .....	2.63 m (*8 ft 7.7 in)	3.50 m (11 ft 5.6 in)
G. Digging depth, 610 mm (2 ft) level bottom .....	1.97 m (6 ft 5.5 in)	2.93 m (9 ft 7.5 in)
H. Digging Depth, 2.4 m (8 ft) level bottom .....	4.51 m (*14 ft 9.6 in)	5.57 m (18 ft 3.3in)
	4.47 m (14 ft 8.1 in)	5.54 m (18 ft 2.1 in)
	4.20 m (13 ft 9.2 in)	5.32 m (17 ft 5.7 in)

\* Maximum height and maximum reach are not obtainable at the same time and the same backhoe position.

## EXTENDAHOE LIFT CAPACITY - RETRACTED 580 SUPER L

### Boom and Dipper Lift

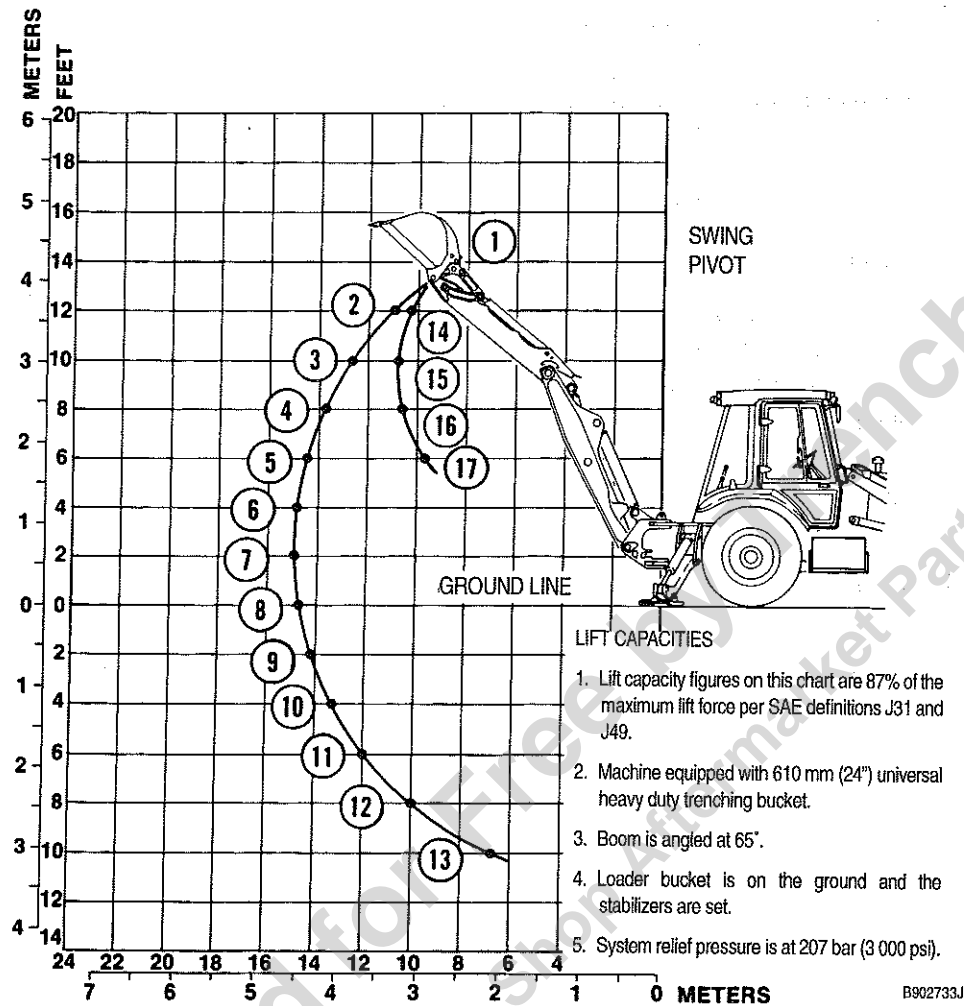

### Backhoe Straight to Rear

kg (Pounds)		kg (Pounds)	
1.	904 (1 994)	10.	972 (2 145)
2.	1 074 (2 368)	11.	974 (2 149)
3.	1 157 (2 551)	12.	976 (2 153)
4.	1 161 (2 560)	13.	1 026 (2 262)
5.	1 153 (2 542)	14.	1 859 (4 100)
6.	1 141 (2 516)	15.	1 741 (3 840)
7.	1 125 (2 481)	16.	1 777 (3 920)
8.	1 030 (2 271)	17.	1 995 (4 400)
9.	1 010 (2 227)		

### Backhoe within Swing Arc

kg (Pounds)		kg (Pounds)	
1.	888 (1 959)	14.	2 013 (4 439)
2.	1 086 (2 394)	15.	1 825 (4 025)
3.	1 157 (2 551)	16.	1 855 (4 091)
4.	1 165 (2 568)	17.	1 875 (4 134)
5.	1 165 (2 568)		
6.	1 141 (2 516)		
7.	1 125 (2 481)		
8.	1 109 (2 446)		

## EXTENDAHOE LIFT CAPACITY - EXTENDED 580 SUPER L

### Boom and Dipper Lift

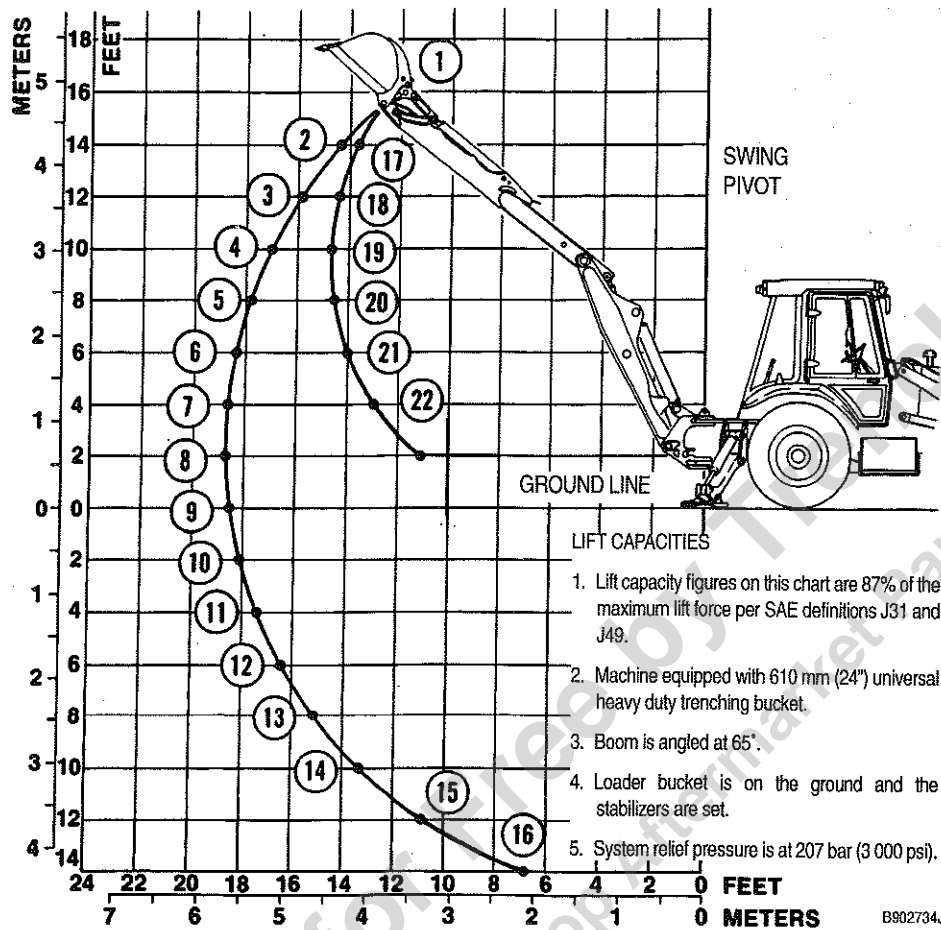

### Backhoe Straight to Rear

kg (Pounds)		kg (Pounds)	
1.	585 (1 289)	12.	809 (1 785)
2.	727 (1 603)	13.	813 (1 794)
3.	786 (1 733)	14.	837 (1 846)
4.	821 (1 811)	15.	910 (2 007)
5.	835 (1 842)	16.	1 092 (2 407)
6.	837 (1 846)	17.	1 239 (2 734)
7.	837 (1 846)	18.	1 285 (2 834)
8.	837 (1 846)	19.	1 291 (2 847)
9.	835 (1 842)	20.	1 372 (3 025)
10.	817 (1 803)	21.	1 387 (3 160)
11.	809 (1 785)	22.	1 451 (3 199)

### Backhoe within Swing Arc

kg (Pounds)		kg (Pounds)	
1.	636 (1 402)	17.	1 239 (2 734)
2.	754 (1 663)	18.	1 271 (2 803)
3.	802 (1 768)	19.	1 247 (2 751)
4.	841 (1 855)	20.	1 338 (2 951)
5.	841 (1 855)	21.	1 346 (2 968)
6.	841 (1 855)	22.	1 425 (3 142)
7.	841 (1 855)		
8.	833 (1 837)		

## EXTENDAHOE LIFT CAPACITY - 580 SUPER L (2WD)

### Extendable Dipper Lift (Extended)

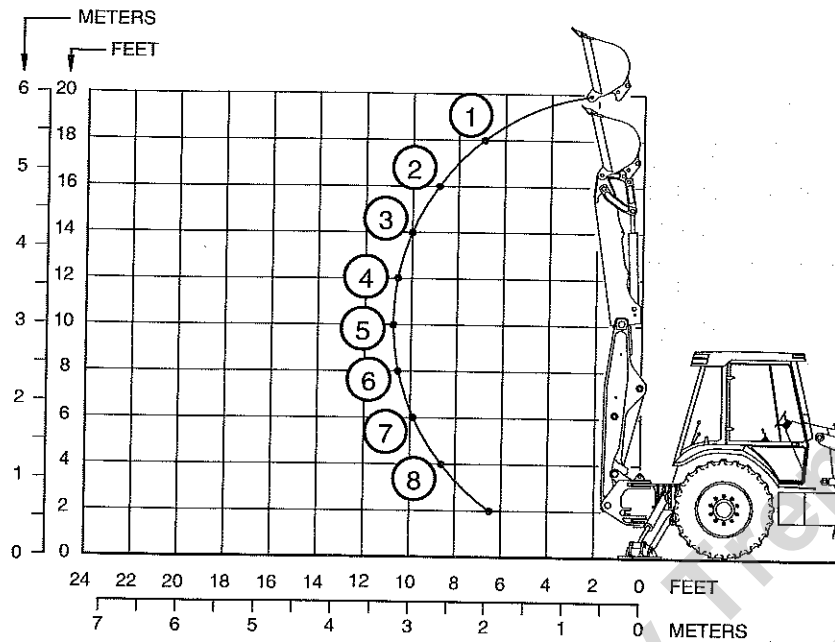

B9505173T

#### LIFT CAPACITIES

1. Lift capacity figures on this chart are 87% of the maximum lift force per SAE J31 and J49.
2. Machine equipped with 610 mm (24 in) Universal H.D. bucket.
3. Boom is latched in transport position.
4. Loader bucket is on the ground and the stabilizers are set.
5. System relief pressure is at 207 bars (3 000 psi).

**NOTE:** Lift Capacities may be increased by 68 kg (150 lbs) when the 610 mm (24 in) Standard Trenching Bucket and links are used in place of the 610 mm (24 in) Universal H.D. bucket with Case Coupler.

### Backhoe Straight to Rear

	kg	(Pounds)
1.	2 477	(5 464)
2.	1 980	(4 367)
3.	1 649	(3 637)
4.	1 420	(3 132)
5.	1 233	(2 719)
6.	1 069	(2 358)
7.	911	(2 010)
8.	734	(1 618)

### Backhoe within Swing Arc

	kg	(Pounds)
1.	2 359	(5 203)
2.	1 909	(4 211)
3.	1 610	(3 550)
4.	1 404	(3 097)
5.	1 144	(2 523)
6.	1 073	(2 366)
7.	907	(2 001)
8.	734	(1 618))

## EXTENDAHOE LIFT CAPACITY - 580 SUPER L (2WD)

## Extendable Dipper Lift (Retracted)

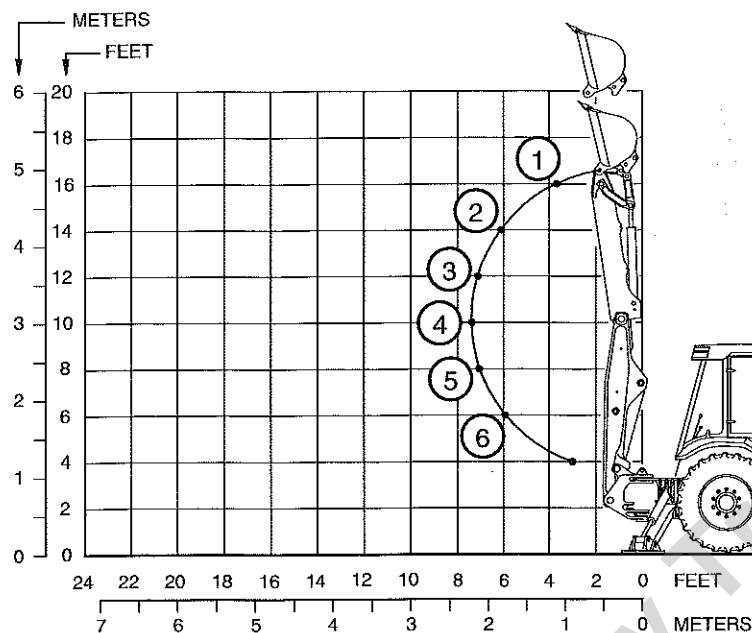

## LIFT CAPACITIES

1. Lift capacity figures on this chart are 87% of the maximum lift force per SAE J31 and J49.
2. Machine equipped with 610 mm (24 in) Universal H.D. bucket.
3. Boom is latched in transport position.
4. Loader bucket is on the ground and the stabilizers are set.
5. System relief pressure is at 207 bars (3 000 psi).

**NOTE:** Lift Capacities may be increased by 68 kg (150 lbs) when the 610 mm (24 in) Standard Trenching Bucket and links are used in place of the 610 mm (24 in) Universal H.D. bucket with Case Coupler.

## Backhoe Straight to Rear

	kg	(Pounds)
1.	5 057	(11 153)
2.	3 327	(7 338)
3.	2 615	(5 768)
4.	2 142	(4 724)
5.	1 752	(3 863)
6.	1 310	(2 888)

This page left blank.

## SPECIFICATIONS - 590 SUPER L

### ENGINE DATA - 590 SUPER L

Make and model.....	Case 4T-390
Firing order .....	1-3-4-2
Air induction .....	Turbocharged
Bore and stroke .....	102 x 120 mm (4.02 x 4.72 inches)
Displacement .....	3.92 litres (239 cu in)
Compression ratio .....	17.5 to 1
Fuel .....	See page 146
Horsepower - rated	
SAE net .....	(with A/C) 65 kW at 2 200 r/min (87.1 at 2 200 rpm)
SAE net .....	(without A/C) 65.9 kW at 2 200 r/min (88.4 at 2 200 rpm)
SAE gross .....	71 kW at 2 200 r/min (95.2 at 2 200 rpm)
Engine speeds	
Full throttle - no load .....	2 300 to 2 400 rpm
Full throttle - full load .....	2 200 rpm
Idle speed .....	900 to 975 rpm
Loader hydraulic stall .....	2 260 to 2 310 rpm
Torque converter stall .....	2 060 to 2 225 rpm
Combined stall .....	1 405 to 1 665 rpm
Valve clearance - engine cold	
Intake valves .....	0.254 mm (0.010 inch)
Exhaust valves .....	0.508 mm (0.020 inch)

### BOLT TORQUES

Front wheel mounting bolts (2 wheel drive) .....	156 to 203 Nm1 (15 to 150 pound-feet)
Front wheel mounting nuts (4 wheel drive) .....	270 to 352 Nm (200 to 260 pound-feet)
Rear wheel mounting nuts .....	129 to 136 Nm (95 to 100 pound-feet)

Then turn in the tightening direction an additional 55 to 65 degrees. This applies to the rear wheel nuts only

### MAIN RELIEF VALVE PRESSURES - 590 SUPER L

Loader and backhoe .....	207 + 0 - 7 bar (3 000 + 0 - 100 psi)
--------------------------	--

(The loader control valve controls the loader and backhoe hydraulic pressure.)

**TRAVEL SPEEDS - 590 SUPER L****Measured with 21L x 24 Tires**

	1st km/h (mph)	2nd km/h (mph)	3rd km/h (mph)	4th km/h (mph)
Forward	5.99 (3.72)	10.81 (6.72)	20.80 (12.92)	40.99 (25.47)
Reverse	7.72 (4.49)	13.03 (8.10)	25.03 (15.55)	48.58 (30.19)

**NOTE:** (Travel speeds measured at 2 351 engine rpm with zero torque converter slip.)

**OPERATING WEIGHTS - 590 SUPER L****Lightest Configuration**

2 362 mm (93 inch) standard bucket, 2WD, 21L x 24 rear tires, 14.5/75L x 16 front tires, no front counterweight, standard dipper, cast stabilizer pads, non-suspension seat, ROPS canopy, single battery, no air conditioner and no operator ..... 7 333 kg (16 166 pounds)

**Heaviest Configuration**

2362 mm (93inch) 4-in-1 bucket, 4WD, 21L x 24 rear tires, 14 x 17.5 front tires, 441 pound front counterweight, extendahoe, 610 mm (24 inch) HD bucket, flip over stabilizer pads, suspension seat, ROPS Cab, Air Conditioner, Dual Batteries, with a 79 kg (175 pound) operator, and mechanical front wheel drive guard ..... 7 948 kg (17 522 pounds)

**LOADER BUCKETS - 590 SUPER L**

Width mm (Inch)	Type	Capacities SAE Heaped m <sup>3</sup> (cu yds)	Capacities Struck m <sup>3</sup> (cu yds)	Weight kg (lbs)
2 362 (93)	Standard	1.0 (1.3)	0.8 (1.1)	509 (1 123)
2 362 (93)	4-in-1	0.92 (1.2)	0.7 (1.0)	738 (1 628)

**BACKHOE BUCKETS - 590 SUPER L**

Width mm (Inch)	Type	Capacities SAE Heaped m <sup>3</sup> (cu feet)	Capacities Struck m <sup>3</sup> (cu feet)	Weight kg (lbs)
305 (12)	Universal HD	0.082 (2.90)	0.068 (2.41)	141 (311)
406 (16)	Universal HD	0.101 (3.60)	0.083 (2.92)	157 (346)
457 (18)	Universal HD	0.122 (4.30)	0.094 (3.33)	163 (359)
610 (24)	Universal HD	0.181 (6.40)	0.135 (4.77)	195 (429)
762 (30)	Universal HD	0.245 (8.65)	0.176 (6.22)	225 (496)
914 (36)	Universal HD	0.306 (10.80)	0.217 (7.67)	259 (571)
610 (24)	High Capacity HD	0.241 (8.50)	0.195 (6.90)	195 (430)
762 (30)	High capacity HD	0.300 (10.60)	0.243 (8.60)	203 (447)

### BASIC MACHINE DIMENSIONS - 590 SUPER L

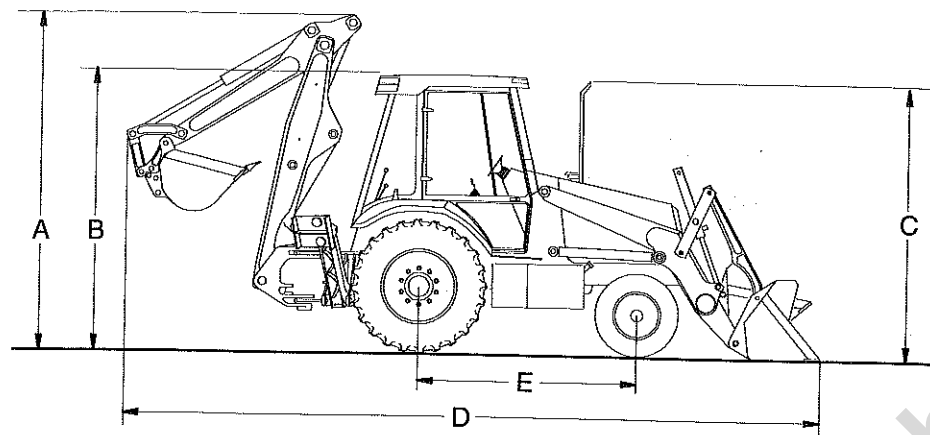

BT95J025

- A Overall height - backhoe in transport position
  - 2 Wheel drive ..... 3.51 m (11 ft 6 in)
  - 4 Wheel drive ..... 3.50 m (11 ft 5.8 in)
- B Height to top of ROPS canopy
  - 2 Wheel drive ..... 2.70 m (8 ft 10.5in)
  - 4 Wheel drive ..... 2.71 m (8 ft 10.6 in)
- B Height to top of ROPS cab
  - 2 Wheel drive ..... 2.73 m (8 ft 11.4 in)
  - 4 Wheel drive ..... 2.72 m (8 ft 11.2 in)
- C Height to top of exhaust stack
  - 2 Wheel drive ..... 2.63 m (8 ft 7.6 in)
  - 4 Wheel drive ..... 2.62 m (8 ft 7.2 in)
- D Overall length - backhoe in transport position
  - 2 362 mm (93 inch) standard bucket ..... 7.18 m (23 ft 6.6 in)
  - 2 362 mm (93 inch) 4-in-1 bucket ..... 7.12 m (23 ft 4.2 in)
- E Wheel base
  - 2 Wheel drive ..... 2 134 mm (84.0 inches)
  - 4 Wheel drive ..... 2 146 mm (84.5 inches)
- Width over tires
  - 14.5/75 L x 16.1 tires..... 2 136 mm (84.1 inches)
  - 14 x 17.5 tires..... 2 245 mm (88.4 inches)
  - 21L x 24 tires ..... 2 332 mm (91.8 inches)
- Ground clearance at backhoe frame ..... 376 mm (14.8 inches)

**NOTE:** Specifications on 2 wheel drive machines are measured with 14.5/75L x 16.1 front tires and 21L x 24 rear tires. Specifications on 4 wheel drive machines are measured with 14 x 17.5 front tires and 21L x 24 rear tires.

### LOADER OPERATING DATA AND DIMENSIONS - 590 SUPER L

#### 2 362 mm (93 inch) Standard Bucket

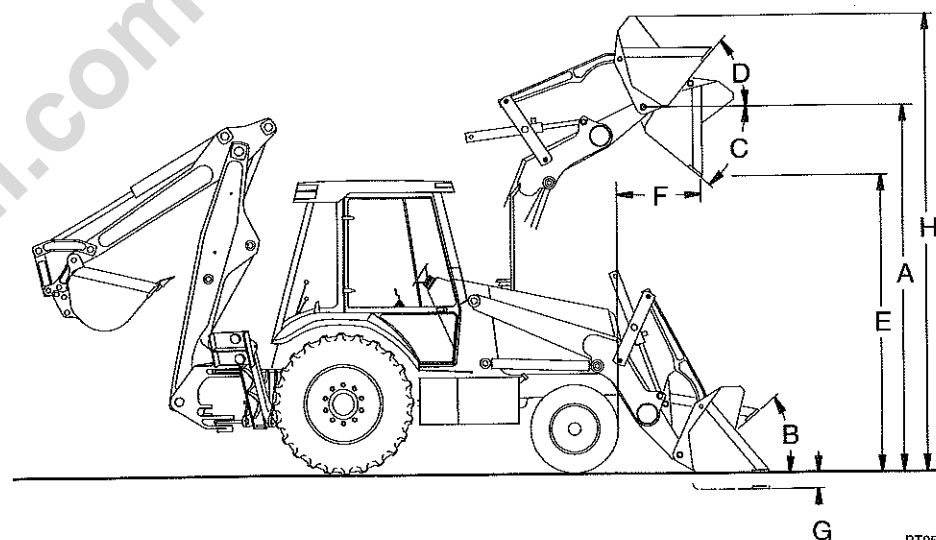

BT95J023

- Lift capacity to full height ..... 3 524 kg (7 770 pounds)
- A Height to bucket hinge pin - raised
  - 2 Wheel drive ..... 3.46 m (11 ft 4.1 in)
  - 4 Wheel drive ..... 3.47 m (11 ft 4.6 in)
- B Bucket rollback at groundline ..... 40°
- C Dump angle at full height ..... 45°
- D Rollback at full height ..... Adjustable
- Maximum grading angle ..... 116°
- E Dump clearance at full height - 45° dump
  - 2 Wheel drive ..... 2.74 m (8 ft 11.8 in)
  - 4 Wheel drive ..... 2.75 m (9 ft 0.4 in)
- F Dump reach at full height - 45° dump ..... 659 mm (25.9 inches)
- G Digging depth below ground line with bucket flat
  - 2 Wheel drive ..... 99 mm (3.9 inches)
  - 4 Wheel drive ..... 109 mm (3.8 inches)
- H Overall height
  - 2 Wheel drive ..... 4.31 m (14 ft 1.6 in)
  - 4 Wheel drive ..... 4.32 m (14 ft 2.0 in)

## LOADER OPERATING DATA AND DIMENSIONS - 590 SUPER L

2 362 mm (93 inch) 4-in-1 Bucket

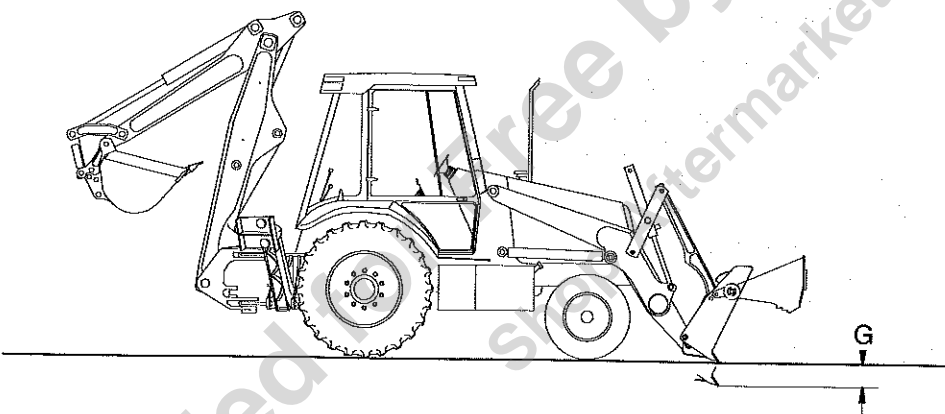
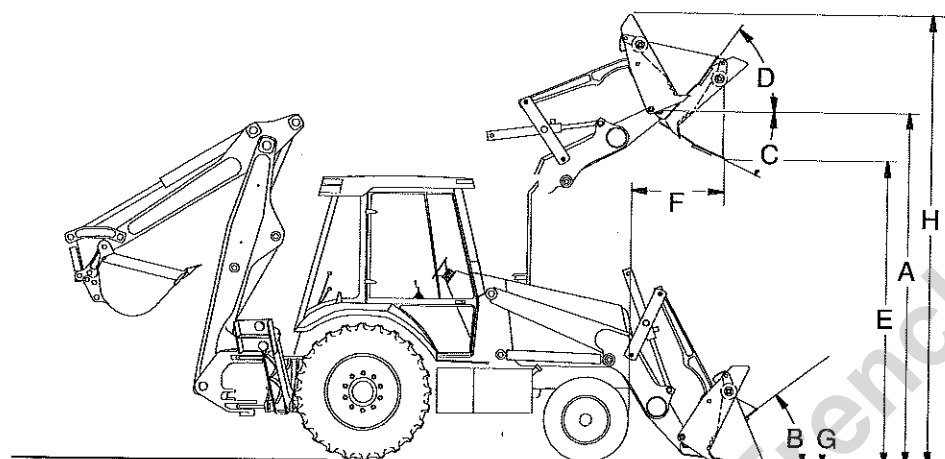

BT95j024

	Lift capacity to full height .....	3 493 kg (7 700 pounds)
A	Height to bucket hinge pin - raised	
	2 Wheel drive .....	3.46 m (11 ft 4.1 in)
	4 Wheel drive .....	3.47 m (11 ft 4.6 in)
B	Bucket rollback at groundline .....	40°
C	Dump angle at full height .....	45°
D	Rollback at full height .....	Adjustable
	Maximum grading angle .....	116°
E	Dump clearance at full height - 45° dump	
	2 Wheel drive	
	Clam open .....	2.99 m (9 ft 9.8 in)
	Clam closed .....	2.77 m (9 ft 1.1 in)
	4 Wheel drive	
	Clam open .....	3.01 m (9 ft 10.4 in)
	Clam closed .....	2.79 m (9 ft 1.7 in)
F	Dump reach at full height - 45° dump	
	Clam open .....	258 mm (10.2 inches)
	Clam closed .....	603 mm (23.7 inches)
G	Digging depth below ground line with bucket flat	
	2 Wheel drive .....	112 mm (4.4 inches)
	4 Wheel drive .....	109 mm (4.3 inches)
	Dozing depth, clam open	
	2 Wheel drive .....	45 mm (1.8 inches)
	4 Wheel drive .....	42 mm (1.7 inches)
H	Overall height	
	2 Wheel drive .....	4.42 m (14 ft 5.8 in)
	4 Wheel drive .....	4.43 m (14 ft 6.3 in)

### BACKHOE OPERATING DATA AND DIMENSIONS - 590 SUPER L

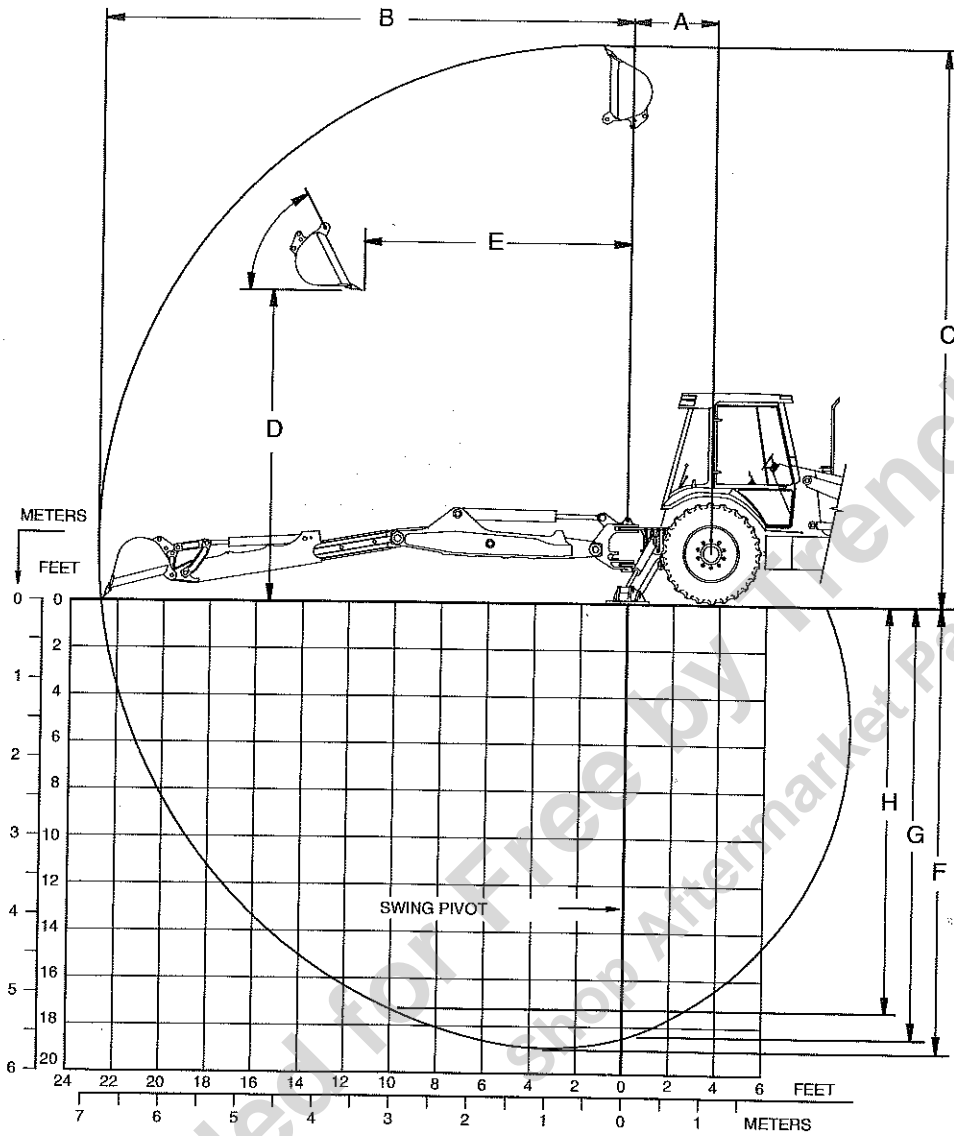

BT95J097

**NOTE:** Specifications taken with 2 wheel drive, 610 mm (24 inch) universal HD backhoe bucket, 21L x 24 rear tires.

A	Swing pivot to rear axle centerline .....	1.10 m (3 ft 7.3 in)
B	Digging radius from swing pivot .....	5.99 m (19 ft 7.6 in)
C	Maximum height .....	4.76 m (15 ft 7.5 in)
D	Loading height .....	3.48 m (11 ft 5.1 in)
E	Loading reach .....	2.90 m (9 ft 6.3 in)
F	Digging depth .....	4.76 m (15 ft 7.4 in)
G	Digging depth, 610 mm (2 ft) flat bottom trench .....	4.74 m (15 ft 6.5 in)
H	Digging depth, 2.4 m (8 ft) flat bottom trench .....	4.45 m (14 ft 11 in)

## BACKHOE LIFT CAPACITY - 590 SUPER L

### Boom and Dipper Lift

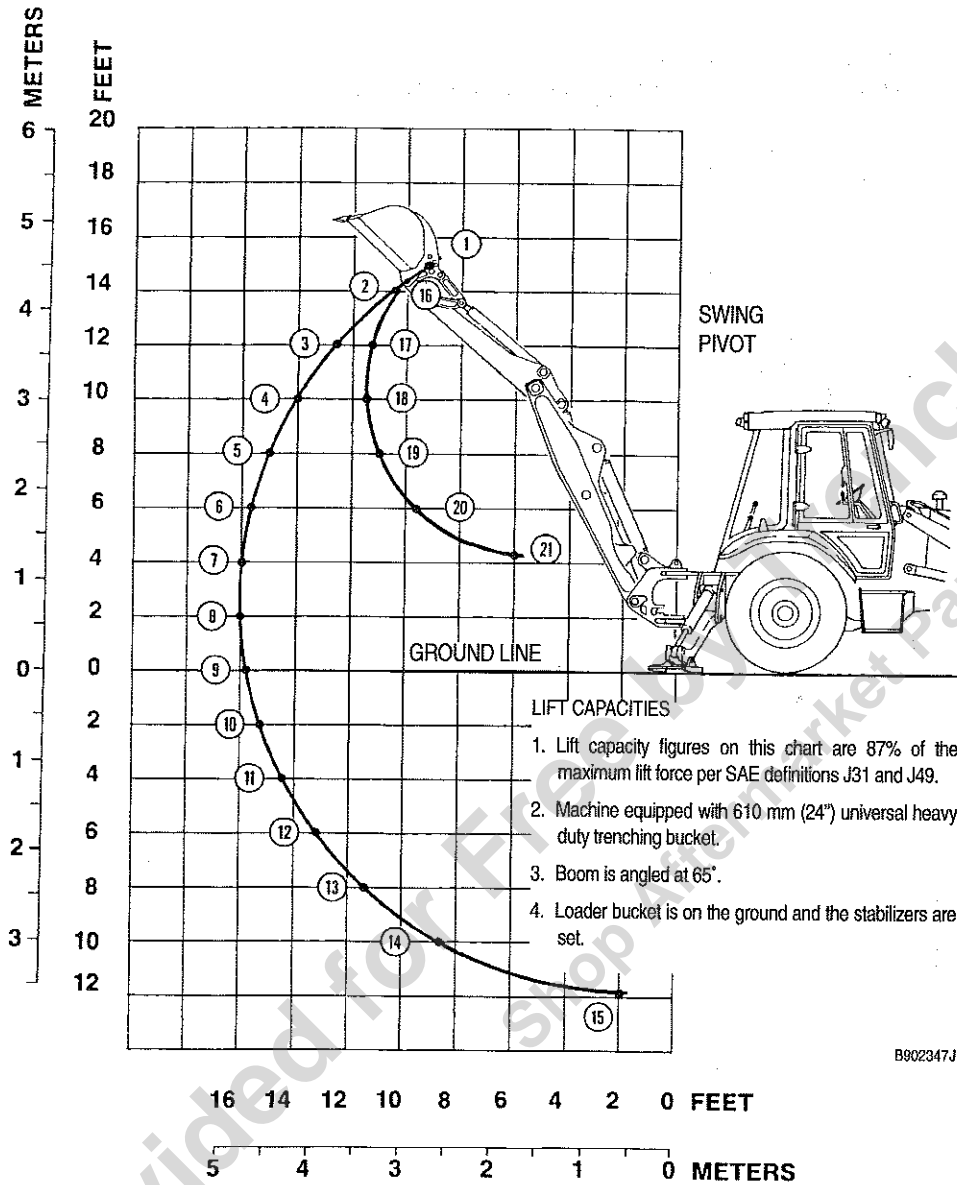

B902347J

**NOTE:** Specifications taken with 2 wheel drive, 610 mm (24 inch) universal HD backhoe bucket, 21L x 24 rear tires.

### Backhoe Straight to Rear

kg (Pounds)		kg (Pounds)	
1. 1 257	(2 772)	12. 1 333	(2 939)
2. 1 574	(3 472)	13. 1 295	(2 857)
3. 1 608	(3 546)	14. 1 298	(2 862)
4. 1 610	(3 551)	15. 1 286	(2 836)
5. 1 587	(3 499)	16. 2 106	(4 644)
6. 1 554	(3 427)	17. 2 319	(5 115)
7. 1 516	(3 343)	18. 2 445	(5 392)
8. 1 479	(3 261)	19. 2 520	(5 557)
9. 1 458	(3 216)	20. 2 469	(5 445)
10. 1 426	(3 145)	21. 2 845	(6 275)
11. 1 362	(3 003)		

### Backhoe within Swing Arc

kg (Pounds)		kg (Pounds)	
1. 1 166	(2 572)	16. 2 159	(4 762)
2. 1 501	(3 309)	17. 2 273	(5 012)
3. 1 598	(3 524)	18. 2 241	(4 942)
4. 1 619	(3 571)	19. 2 249	(4 961)
5. 1 602	(3 534)	20. 2 378	(5 243)
6. 1 587	(3 501)	21. 3 031	(6 684)
7. 1 559	(3 439)		

## BACKHOE LIFT CAPACITY - 590 SUPER L

### Dipper Lift

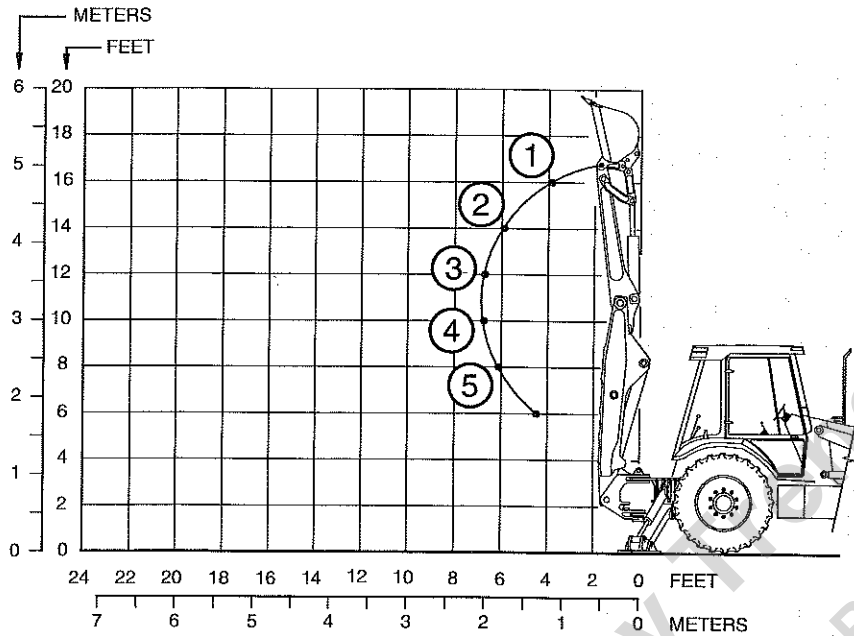

### LIFT CAPACITIES

1. Lift capacity figures on this chart are 87% of the maximum lift force per SAE J31 and J49.
2. Machine equipped with 610 mm (24 in) Hi Capacity H.D. bucket.
3. Boom is latched in transport position.
4. Loader bucket is on the ground and the stabilizers are set.
5. System relief pressure is at 200 bars (2 900 psi).

*Lift Capacities may be increased by 68 kg (150 lbs) when the 610 mm (24 in) Standard Trenching Bucket and links are used in place of the 610 mm (24 in) Hi Capacity H.D. bucket with Case Coupler.*

### Backhoe Straight to Rear

	kg	(Pounds)
1.	3 735	(8 236)
2.	2 858	(6 303)
3.	2 307	(5 089)
4.	1 919	(4 232)
5.	1 519	(3 350)

### Backhoe within Swing Arc

	kg	(Pounds)
1.	3 744	(8 257)
2.	3 289	(7 254)
3.	2 375	(5 237)
4.	2 045	(4 509)
5.	1 618	(3 569)

# EXTENDAHOE OPERATING DATA AND DIMENSIONS - 590 SUPER L

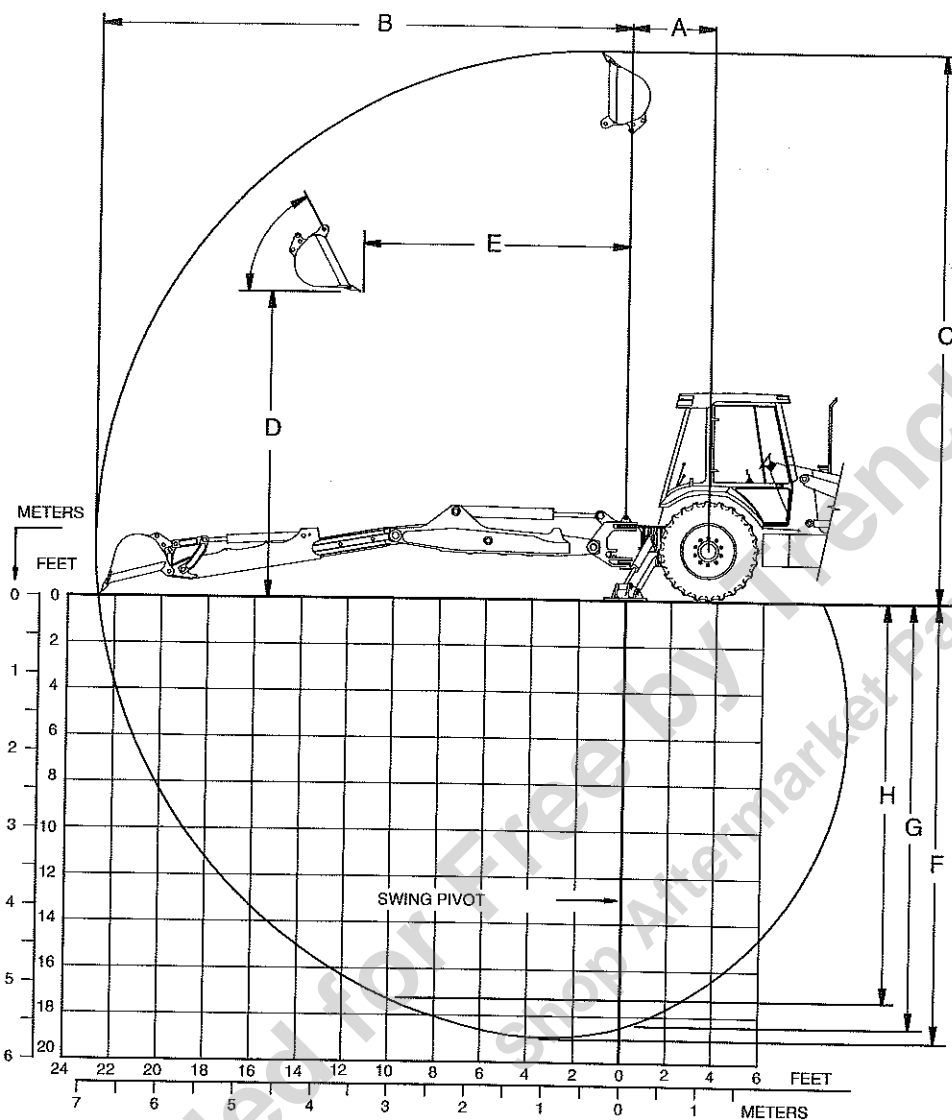

BT95J097

**NOTE:** Specifications taken with 610 mm (24 inch) universal heavy duty trenching bucket, 21L x 24 rear tires.

	Retracted	Extended
A. Swing pivot to rear axle centerline .....	1.10 m (3 ft 7.3 in)	1.10 m (3 ft 7.3 in)
B. Digging radius from swing pivot .....	5.99 m (19 ft 7.6 in)	7.19 m (23 ft 6.9 in)
C. Maximum height.....	6.38 m (20 ft 11 in)	7.57 m (24 ft 10 in)
D. Loading height .....	3.48 m (11 ft 5.1 in)	4.20 m (13 ft 9.2 in)
E. Loading reach .....	2.90 m (9 ft 6.3 in)	3.89 m (12 ft 9.3 in)
F. Digging Depth .....	4.76 m (15 ft 7.4 in)	5.98 m (19 ft 7.4 in)
G. Digging depth, 610 mm (2 ft) level bottom .....	4.72 m (15 ft 5.8 in)	5.94 m (19 ft 5.8 in)
H. Digging Depth, 2.4 m (8 ft) level bottom .....	4.55 m (14 ft 11 in)	5.84 m (19 ft 2 in)

## EXTENDAHOE LIFT CAPACITY - RETRACTED 590 SUPER L

### Boom and Dipper Lift

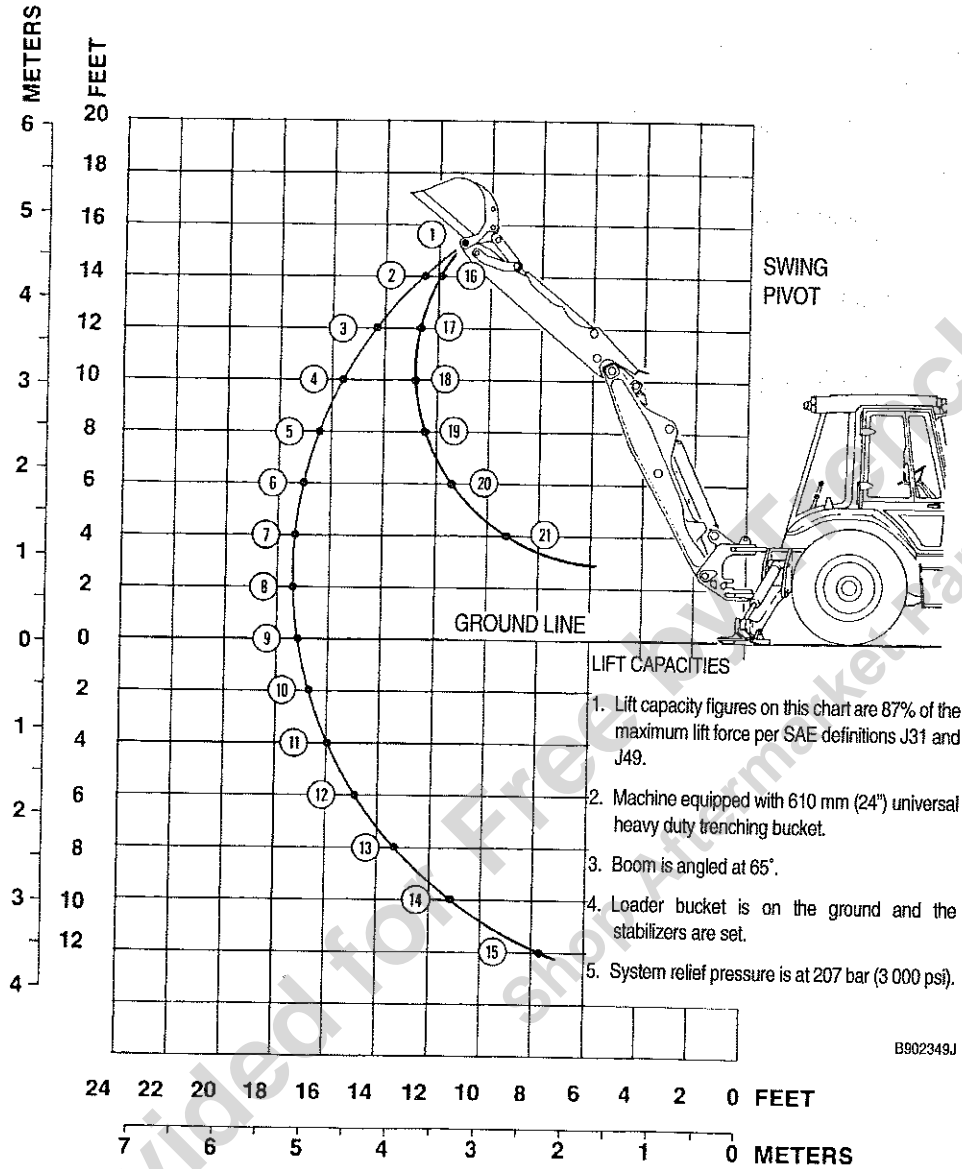

### Backhoe Straight to Rear

kg (Pounds)		kg (Pounds)	
1.	-NA- (-NA-)	12.	1 251 (2 760)
2.	1 449 (3 196)	13.	1 243 (2 741)
3.	1 438 (3 171)	14.	1 231 (2 714)
4.	1 494 (3 296)	15.	1 263 (2 786)
5.	1 461 (3 222)	16.	2 126 (4 688)
6.	1 485 (3 276)	17.	2 327 (5 132)
7.	1 439 (3 173)	18.	2 414 (5 324)
8.	1 407 (3 102)	19.	2 507 (5 529)
9.	1 367 (3 015)	20.	2 518 (5 553)
10.	1 320 (2 911)	21.	2 887 (6 368)
11.	1 294 (2 854)		

### Backhoe within Swing Arc

kg (Pounds)		kg (Pounds)	
2.	1 458 (3 215)	16.	2 245 (4 951)
3.	1 544 (3 406)	17.	2 368 (5 223)
4.	1 542 (3 400)	18.	2 459 (5 423)
5.	1 533 (3 381)	19.	2 492 (5 497)
6.	1 485 (3 276)	20.	2 559 (5 644)
7.	1 459 (3 218)	21.	2 841 (6 266)
8.	1 449 (3 195)		
9.	1 074 (3 088)		

## EXTENDAHOE LIFT CAPACITY - EXTENDED 590 SUPER L

### Boom and Dipper Lift

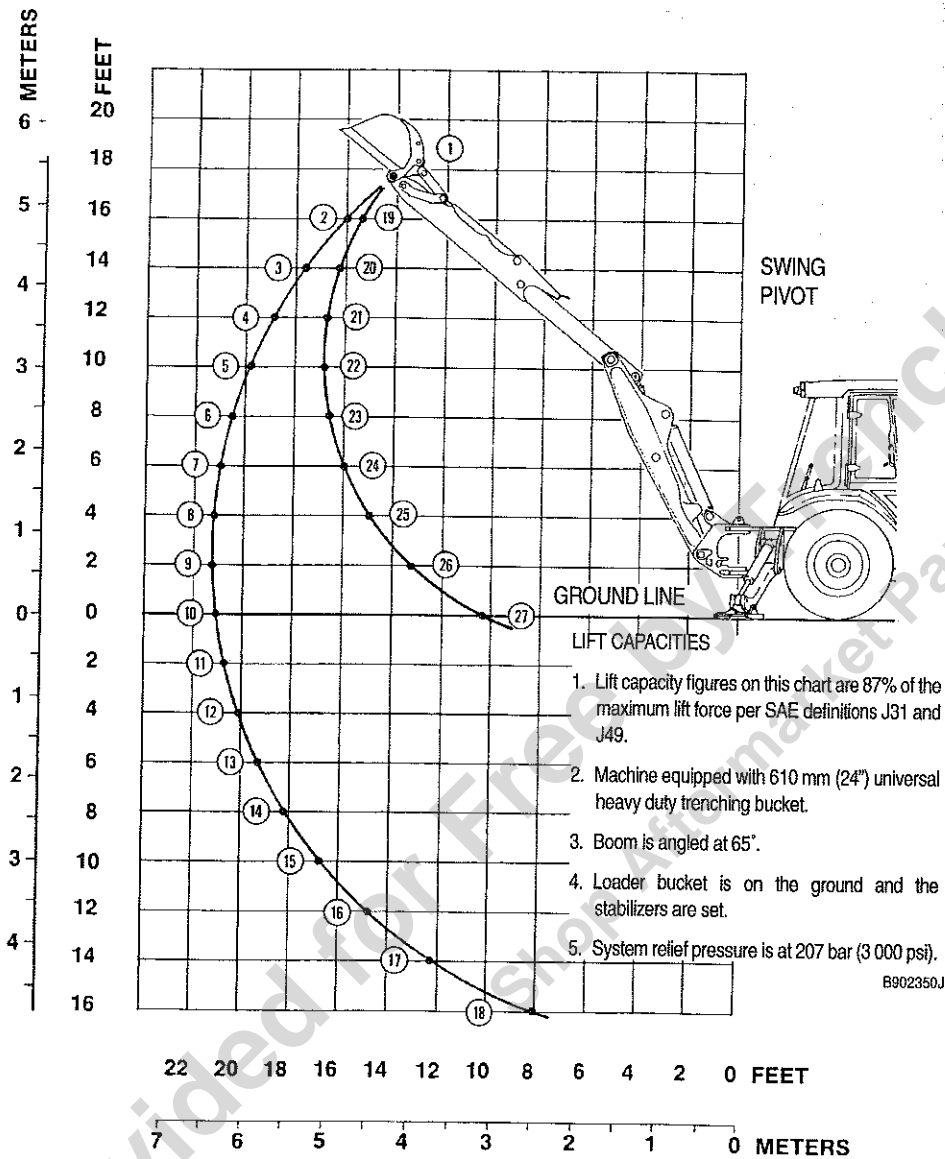

### Backhoe Straight to Rear

kg (Pounds)		kg (Pounds)	
1.	852 (1 878)	15.	916 (2 021)
2.	964 (2 125)	16.	954 (2 103)
3.	1 009 (2 226)	17.	980 (2 161)
4.	1 062 (2 342)	18.	1 093 (2 410)
5.	1 039 (2 291)	19.	1 230 (2 714)
6.	1 061 (2 339)	20.	1 288 (2 840)
7.	1 061 (2 339)	21.	1 350 (2 977)
8.	1 013 (2 235)	22.	1 358 (2 995)
9.	1 006 (2 218)	23.	1 381 (3 045)
10.	992 (2 188)	24.	1 400 (3 087)
11.	978 (2 157)	25.	1 444 (3 184)
12.	975 (2 150)	26.	1 464 (3 228)
13.	939 (2 071)	27.	1 563 (3 447)
14.	926 (2 043)		

### Backhoe within Swing Arc

kg (Pounds)		kg (Pounds)	
1.	824 (1 817)	19.	1 309 (2 886)
2.	949 (2 093)	20.	1 355 (2 988)
3.	981 (2 164)	21.	1 387 (3 058)
4.	1 028 (2 268)	22.	1 404 (3 097)
5.	1 024 (2 259)	23.	1 413 (3 115)
6.	1 046 (2 306)	24.	1 439 (3 175)
7.	1 098 (2 421)	25.	1 473 (3 249)
8.	1 069 (2 358)	26.	1 586 (3 498)
9.	1 079 (2 379)	27.	2 004 (4 419)
10.	1 074 (2 369)		

## EXTENDAHOE LIFT CAPACITY - 590 SUPER L

## Extendable Dipper Lift (Extended)

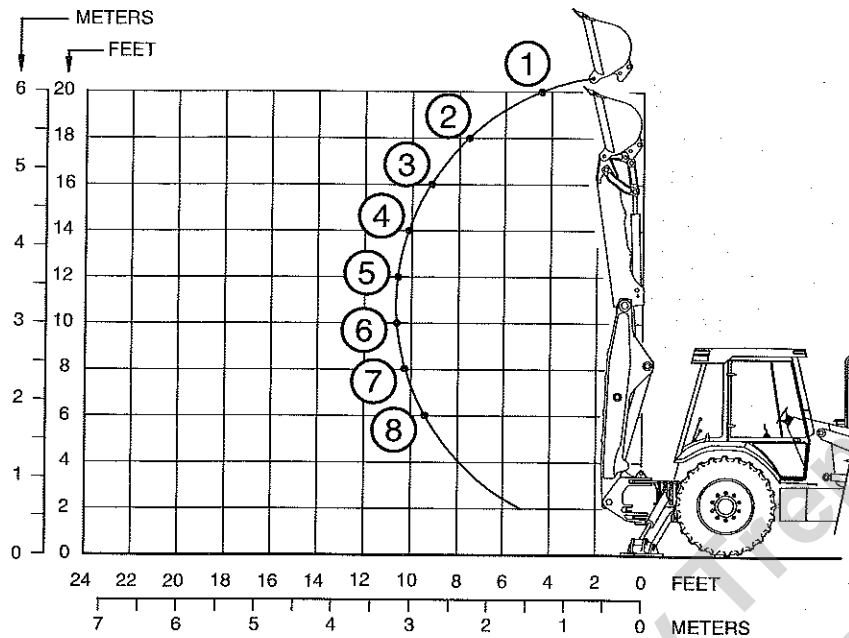

## LIFT CAPACITIES

1. Lift capacity figures on this chart are 87% of the maximum lift force per SAE J31 and J49.
2. Machine equipped with 610 mm (24 in) Hi Capacity H.D. bucket.
3. Boom is latched in transport position.
4. Loader bucket is on the ground and the stabilizers are set.
5. System relief pressure is at 200 bars (2 900 psi).

*Lift Capacities may be increased by 68 kg (150 lbs) when the 610 mm (24 in) Standard Trenching Bucket and links are used in place of the 610 mm (24 in) Hi Capacity H.D. bucket with Case Coupler.*

## Backhoe Straight to Rear

	kg	(Pounds)
1.	2 596	(5 725)
2.	1 989	(4 387)
3.	1 687	(3 720)
4.	1 436	(3 167)
5.	1 207	(2 662)
6.	1 082	(2 386)
7.	898	(1 980)
8.	725	(1 600)

## Backhoe within Swing Arc

	kg	(Pounds)
1.	2 478	(5 464)
2.	1 994	(4 398)
3.	1 663	(3 667)
4.	1 413	(3 116)
5.	1 228	(2 709)
6.	1 078	(2 378)
7.	987	(2 178)
8.	815	(1 798)

## EXTENDAHOE LIFT CAPACITY - 590 SUPER L

### Extendable Dipper Lift (Retracted)

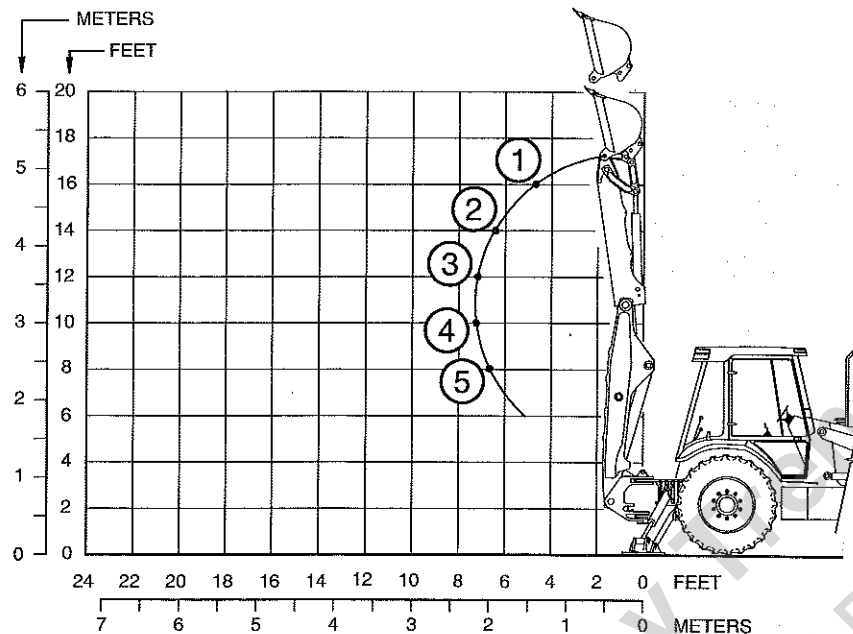

B9505173X

#### LIFT CAPACITIES

1. Lift capacity figures on this chart are 87% of the maximum lift force per SAE J31 and J49.
2. Machine equipped with 610 mm (24 in) Hi Capacity H.D. bucket.
3. Boom is latched in transport position.
4. Loader bucket is on the ground and the stabilizers are set.
5. System relief pressure is at 200 bars (2 900 psi).

*Lift Capacities may be increased by 68 kg (150 lbs) when the 610 mm (24 in) Standard Trenching Bucket and links are used in place of the 610 mm (24 in) Hi Capacity H.D. bucket with Case Coupler.*

### Backhoe Straight to Rear

	kg	(Pounds)
1.	3 720	(8 203)
2.	2 897	(6 388)
3.	2 307	(5 087)
4.	1 849	(4 078)
5.	1 443	(3 183)

### Backhoe within Swing Arc

	kg	(Pounds)
1.	3 720	(8 205)
2.	2 902	(6 401)
3.	2 308	(5 090)
4.	1 911	(4 214)
5.	1 575	(3 474)

This page left blank.

## AFTER DELIVERY CHECK

### (After First 50 Hours of Operation of New Machine)

OWNER: Name \_\_\_\_\_

Address \_\_\_\_\_

DEALER: Name \_\_\_\_\_

Address \_\_\_\_\_

MACHINE: Model Number 580L, 580 Super L, and 590 Super L

Product Identification Number (P.I.N.) \_\_\_\_\_

Hourmeter Indication \_\_\_\_\_

#### COOLING SYSTEM

- Check for leaks.
- Check coolant level.

#### ELECTRICAL SYSTEM

- Check battery fluid level and specific gravity.
- Check operation of starter, alternator, instruments, and warning lamps.
- Check operation of all lamps.

#### ENGINE

- Check condition of drive belt.
- Check engine oil level.
- Check engine speed at idle and full throttle.
- Service air cleaner.

#### HYDRAULIC SYSTEM

- Check for leaks.
- Change the hydraulic filter.
- Check the reservoir fluid level.

#### FUEL SYSTEM

- Check for leaks.
- Check the fuel tank for water and sediment.

#### LUBRICATION

- Lubricate all pivot points.
- Check the oil level of the front drive axle (if equipped).
- Check the oil level of the rear axle.
- Check the oil level of the transmission.

#### GENERAL

- Check the wheel nut and bolt torques.
- Check operation of loader and backhoe.
- Check the operation of the foot and parking brakes.

#### SAFETY

- Check the safety and information decals.
- Check the torque of ROPS and seat belt mounting bolts.
- Make sure the Operators Manual and Safety Manual are in the Manual Storage Box.
- Swing lock pin in box.

OWNER: Make sure the new owner/operator understands all the safety and information decals, the service information, and the service procedures in this operator's manual.

Mechanic (signature) \_\_\_\_\_ Date \_\_\_\_\_

Dealer (signature) \_\_\_\_\_ Date \_\_\_\_\_

Owner (signature) \_\_\_\_\_ Date \_\_\_\_\_

**DEALER'S COPY**

## AFTER DELIVERY CHECK

### (After First 50 Hours of Operation of New Machine)

OWNER: Name \_\_\_\_\_

Address \_\_\_\_\_

DEALER: Name \_\_\_\_\_

Address \_\_\_\_\_

MACHINE: Model Number 580L, 580 Super L, and 590 Super L

Product Identification Number (P.I.N.) \_\_\_\_\_

Hourmeter Indication \_\_\_\_\_

#### COOLING SYSTEM

- Check for leaks.
- Check coolant level.

#### ELECTRICAL SYSTEM

- Check battery fluid level and specific gravity.
- Check operation of starter, alternator, instruments, and warning lamps.
- Check operation of all lamps.

#### ENGINE

- Check condition of drive belt.
- Check engine oil level.
- Check engine speed at idle and full throttle.
- Service air cleaner.

#### HYDRAULIC SYSTEM

- Check for leaks.
- Change the hydraulic filter.
- Check the reservoir fluid level.

#### FUEL SYSTEM

- Check for leaks.
- Check the fuel tank for water and sediment.

#### LUBRICATION

- Lubricate all pivot points.
- Check the oil level of the front drive axle (if equipped).
- Check the oil level of the rear axle.
- Check the oil level of the transmission.

#### GENERAL

- Check the wheel nut and bolt torques.
- Check operation of loader and backhoe.
- Check the operation of the foot and parking brakes.

#### SAFETY

- Check the safety and information decals.
- Check the torque of ROPS and seat belt mounting bolts.
- Make sure the Operators Manual and Safety Manual are in the Manual Storage Box.
- Swing lock pin in box.

OWNER: Make sure the new owner/operator understands all the safety and information decals, the service information, and the service procedures in this operator's manual.

Mechanic (signature) \_\_\_\_\_ Date \_\_\_\_\_

Dealer (signature) \_\_\_\_\_ Date \_\_\_\_\_

Owner (signature) \_\_\_\_\_ Date \_\_\_\_\_

**OWNER'S COPY**

This page left blank.

## ALPHABETICAL INDEX

### A

Accumulator .....	167
After Delivery Check .....	.2, 255, 257
Air Conditioning Compressor .....	168
Air Filter	
Cleaning .....	141
Primary Element .....	140
Secondary Element .....	141
Service Specifications .....	139
Air Filter System .....	139
Air Pressure, Tire .....	113
Axle - Front Four Wheel Drive	
Breather .....	159
Oil Change .....	159
Oil Level .....	158
Service Specifications .....	158
Axle - Rear	
Breather .....	157
Oil Change .....	157
Oil Level .....	155
Service Specifications .....	155

### B

Backhoe Auxiliary Hydraulics .....	105
Backhoe Buckets .....	185, 209, 233
Backhoe Grease Fittings .....	124, 126
Backhoe in Transport Position .....	98
Backhoe Operation .....	89
Battery Cleaning .....	176
Battery Fluid Level .....	176
Battery Safety .....	175
Battery Service .....	175
Battery Vents .....	176
Before You Dig With Backhoe .....	91
Booster Battery .....	71
Buckets .....	185, 209, 233
Backhoe .....	185, 209, 233
Case Coupler .....	101
Digging Positions .....	94
Frost Point .....	100
Loader .....	185, 209, 233

### C

Cab	
Air Conditioning .....	168
Air Louvers .....	62
Cleaning the Filter .....	160
Controls .....	60
Door Latch .....	63
Rear Windows .....	64
Window Latch .....	63
Window Retainer .....	63
Case Starting Fluid .....	69
Cleaning the Cooling System .....	145
Clutch Cutout Button .....	.38, 50
Controls	
Auxiliary Attachment for Backhoes .....	55
Backhoe With Foot Swing .....	51
Backhoe With Hand Swing .....	52
Brake Pedal Lock .....	40
Cab (See Cab) .....	60
Clam .....	50
Direction Control Lever .....	37
Extendahoe With Foot Swing .....	53
Extendahoe With Hand Swing .....	54
Foot Pedals .....	39
Front Drive Axle .....	43
Lamp Switches .....	41
Lamps .....	42
Lift Arm and Bucket .....	49
Loader .....	49
Machine .....	37
Transmission Shift Lever .....	38
Coolant Level .....	144
Coolant Reservoir .....	144

### D

Diesel Fuel System .....	146
Digging With Backhoe .....	96
Do Not Operate Tag .....	18
Driving Lamps .....	.42, 178

This page left blank.

<b>E</b>		<b>H</b>	
Electrical System .....	175	Hand Held Auxiliary Hydraulics .....	109
Engine		Hand Signals .....	30
Alarm .....	43	Hydraulic	
Coolant Heater .....	72	Fluid Level .....	150, 151
Coolant Level .....	144	Service Specifications .....	150
Cooling System .....	143	Hydraulic System .....	150
Coolant Solution .....	143		
Service Specifications .....	143	<b>I</b>	
Ether Cold Start Aid .....	70	Identification Numbers .....	3
Hourmeter .....	115	Instrument Cluster .....	179
Lubrication System .....	136	Instruments and Controls .....	35
Oil Filter Replacement .....	137		
Oil Heater .....	72	<b>L</b>	
Oil Recommendations .....	135	Lamp Replacement .....	177
Oil Viscosity Chart .....	135	Lifting With Backhoe .....	103
Opening and Closing the Hood .....	121	Lifting With the Loader .....	88
Operation .....	66	Loader Buckets .....	185, 209, 233
Serial Number .....	3	Loader Grease Fittings .....	122
Starting Aids .....	69	Loader Operation .....	83
Starting with Ether .....	70	Lubrication and Maintenance Charts .....	118, 119
Engine Oil Recommendations .....	133	Lubrication/Filters/Fluids .....	121
Engine Specifications .....	183, 207, 231	Lubrication/Maintenance Charts .....	115
Environment .....	120		
Ether Starting Aid .....	164	<b>M</b>	
Ether Starting Aid Button .....	47	Machine Components .....	6, 7, 8, 9
Extendahoe Lock Pin .....	95	Machine Grease Fittings .....	128
		Machine Operation .....	73
		Machine Storage .....	181
		Maintenance and Adjustments .....	163
		Material Safety Data Sheets .....	18
		Mounting Bolts for ROPS Canopy .....	171
		MSDS Sheets .....	18
		<b>O</b>	
		Oil Change	
		Engine .....	137
		Oil Level	
		Engine .....	136
		Hydraulic .....	150
		Operating in Cold Weather .....	81
		Operating in Hot Weather .....	82
<b>F</b>			
Fan Drive Belt Replacement .....	165		
Fire Extinguisher .....	173		
Flasher Lamp .....	41, 177		
Fluid Levels .....	133		
Fluids and Lubricants .....	117		
4-In-1 Bucket Indicators .....	84		
Front and Rear Flood Lamps .....	42, 178		
Fuel Conditioner .....	147		
Fuel Specifications .....	146		
Fuel System Service Specifications .....	146		
Fuel Tank .....	147		
Fuel Tank Drain .....	147		
Fuses .....	180		
<b>G</b>			
General Safety Before you Service .....	115		

<b>P</b>		<b>S</b>	
P.I.N. Number .....	3	Standard Dipper Lift Capacities .....	194
Parking Brake .....	48	580 Super L .....	207
Parking Brake Alarm .....	43	Backhoe Lift Capacity .....	216, 217
Parking the Machine .....	68	Backhoe Operating Data .....	214, 215
		Basic Machine Dimensions .....	210
		Bolt Torques .....	207
		Buckets .....	209
		Engine Data .....	207
		Extendahoe Dipper Lift	
		Capacities - Extended .....	226
		Extendahoe Dipper Lift	
		Capacities - Retracted .....	228
		Extendahoe Lift	
		Capacity - Extended .....	224, 225
		Extendahoe Lift	
		Capacity - Retracted .....	222, 223
		Extendahoe Operating Data .....	220, 221
		Loader Operating Data .....	211, 212, 213
		Main Relief Valve Pressures .....	207
		Operating Weights .....	208
		Standard Dipper Lift Capacities .....	218
		Travel Speeds .....	208
		580L .....	183
		Backhoe Lift Capacity .....	192, 193
		Backhoe Operating Data .....	190, 191
		Basic Machine Dimensions .....	186
		Bolt Torques .....	183
		Buckets .....	185
		Engine Data .....	183
		Extendahoe Lift Capacity .....	197
		Extendahoe Lift	
		Capacity - Extended .....	200
		Extendahoe Lift	
		Capacity - Extended .....	201
		Extendahoe Lift	
		Capacity Retracted .....	199
		Extendahoe Lift	
		Capacity - Retracted .....	198
		Extendahoe Operating Data .....	196
		Loader Operating Data .....	187, 188, 189
		Main Relief Valve Pressures .....	184
		Operating Weights .....	184
		Travel Speeds .....	184
<b>R</b>			
Radiator .....	144		
Rear Axle - See Axles			
Rear Axle Oil .....	157		
Removal From Storage .....	182		
Return-To-Dig .....	86		
Return-To-Dig Adjustment .....	163		
Ride Control .....	44		
Accumulator .....	167		
Roll-Over Protective Structure .....	169		
Rotating Beacon .....	42		
Run-In Period .....	65		
<b>S</b>			
Safety			
Backhoe Danger Area .....	95		
Before Operation .....	12		
Burn Prevention .....	16		
Fire or Explosion Prevention .....	17		
Hand Signals .....	30		
Machine Operation .....	14		
Maintenance .....	18		
Parking the Machine .....	16		
ROPS Maintenance .....	19		
Safety Rules .....	11		
Wheel and Tire Maintenance .....	19, 20		
Seats			
Belts .....	59		
Standard .....	56		
Suspension .....	57		
Switch/Buzzer System .....	46		
Spark Arrester Muffler .....	166		
Specifications .....	183		
580 L			
Extendahoe Dipper Lift			
Capacities - Extended .....	204		
Extendahoe Dipper Lift			
Capacities - Retracted .....	202		

## ALPHABETICAL INDEX

### S

590 Super L .....	231
Backhoe Lift Capacity .....	240, 241
Backhoe Operating Data .....	238, 239
Basic Machine Dimensions .....	234
Buckets .....	233
Engine Data .....	231
Extendahoe Dipper Lift	
Capacities - Extended .....	250
Extendahoe Dipper Lift	
Capacities - Retracted .....	252
Extendahoe Lift	
Capacity - Extended ...	248, 249
Extendahoe Lift	
Capacity - Retracted ..	246, 247
Extendahoe Operating Data ..	244, 245
Loader Operating Data .....	235, 236
Main Relief Valve Pressures .....	231
Operating Weights .....	232
Standard Dipper Lift Capacities ..	242
Travel Speeds .....	232
Stabilizer Pads .....	89, 90
Standard Bucket Level Indicator .....	84
Starting Engine With Turbocharger .....	67
Starting Fluid .....	69
Starting the Engine .....	66
Starting the Engine with Ether .....	70
Support Strut for Loader Lift Arms .....	116
Switches	
Clutch Cutout .....	50
Dome .....	41
Front Drive Axle .....	43
Hand Throttle .....	47
Key .....	47
Ride Control .....	44
Rotating Beacon .....	42
Systemgard Lubrication Analysis ...	120, 138

### T

To the Owner .....	1
Towing a Disabled Machine .....	78
Engine Running .....	78
Engine Stopped .....	78
Transmission	
Breather Cleaning .....	154
Filter Replacement .....	154
Fluid Change .....	154
Fluid Level .....	153
Service Specifications .....	153
Transporting a Machine on a Trailer .....	79

### W

Walk-Around Inspection .....	66
Weights - Operating .....	209, 233
Wheels and Tires	
Adding Air .....	111
Air Pressures .....	112
Nut and Bolt Torques .....	112
Procedure to Install the Tires .....	113
Service .....	111

## CASE TECHNICAL MANUALS

Manuals are available from your Dealer for the operation, service and repair of your machine. For prompt convenient service, contact your Dealer for assistance in obtaining the manuals for your machine.

Your Dealer can expedite your order for operators manuals, parts catalogs, service manuals and maintenance records.

Always give the Machine Name, Model and P.I.N. (product identification number) or S.N. (serial number) or your machine so your Dealer can provide the correct manuals for your machine.

### CALIFORNIA

#### Proposition 65 Warning

Diesel engine exhaust and some of its constituents are known to the State of California to cause cancer, birth defects, and other reproductive harm.

**NOTE:** Case Corporation reserves the right to make improvements in design or changes in specifications at any time without incurring any obligation to install them on units previously sold.