

8

5

3

8

5

3

H



Service Manual

(S/N 508411001–508417999)

(S/N 509711001–509717999)

(S/N 510250001 & Above)

(S/N 510375001 & Above)

(S/N 512815001–512815999)

(S/N 510125001 & Above)

(S/N 512311001 & Above)

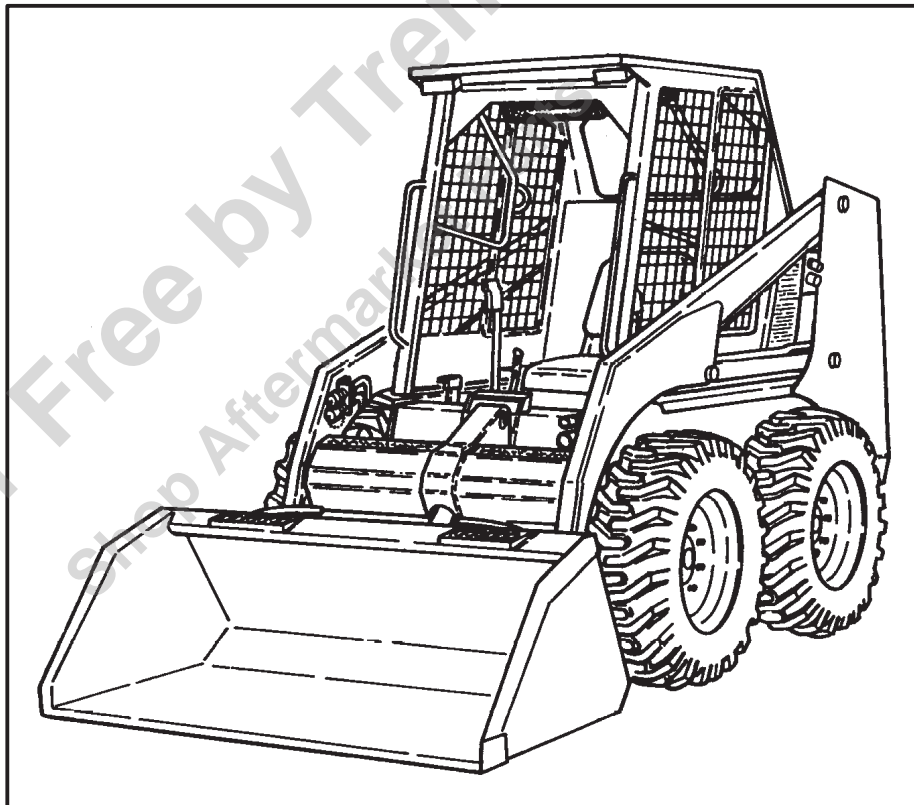

Provided for Free by Trenchwell.com
Shop Aftermarket Parts

MAINTENANCE SAFETY



WARNING

Instructions are necessary before operating or servicing machine. Read and understand the Operation & Maintenance Manual, Operator's Handbook and signs (decals) on machine. Follow warnings and instructions in the manuals when making repairs, adjustments or servicing. Check for correct function after adjustments, repairs or service. Untrained operators and failure to follow instructions can cause injury or death.

W-2003-0903



Safety Alert Symbol: This symbol with a warning statement, means: "Warning, be alert! Your safety is involved!" Carefully read the message that follows.

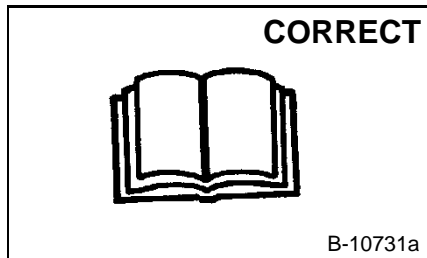

Never service the Bobcat Skid-Steer Loader without instructions.

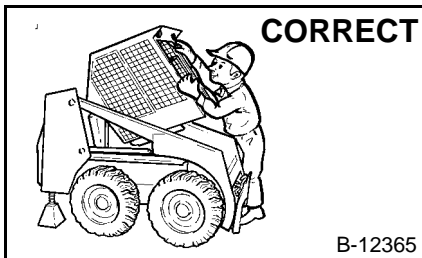

Use the correct procedure to lift or lower operator cab.

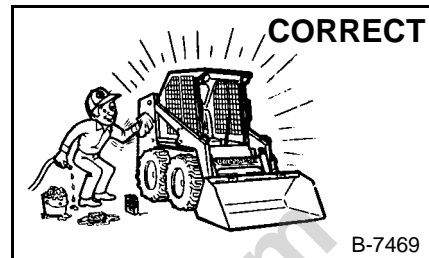

Cleaning and maintenance are required daily.

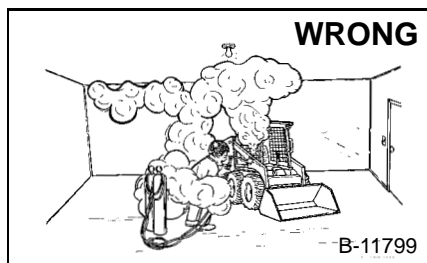

- Have good ventilation when welding or grinding painted parts.
- Wear dust mask when grinding painted parts. Toxic dust and gas can be produced.
- Avoid exhaust fume leaks which can kill without warning. Exhaust system must be tightly sealed.

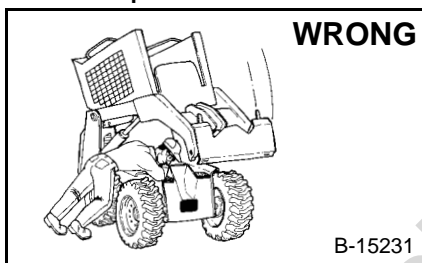

Disconnecting or loosening any hydraulic tubeline, hose, fitting, component or a part failure can cause lift arms to drop. Do not go under lift arms when raised unless supported by an approved lift arm support device. Replace it if damaged.

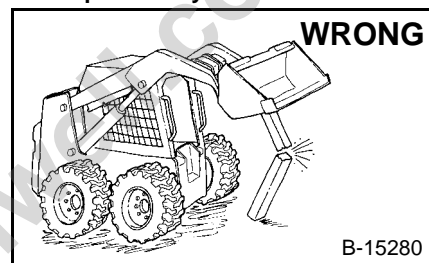

- Never work on loader with lift arms up unless lift arms are held by an approved lift arm support device. Replace if damaged.
- Never modify equipment or add attachments not approved by Bobcat Company.

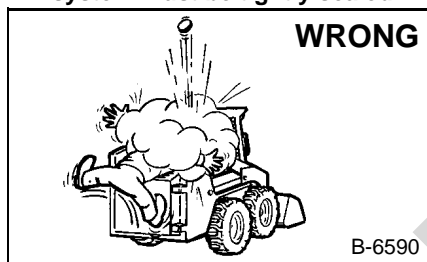

- Stop, cool and clean engine of flammable materials before checking fluids.
- Never service or adjust loader with the engine running unless instructed to do so in the manual.
- Avoid contact with leaking hydraulic fluid or diesel fuel under pressure. It can penetrate the skin or eyes.
- Never fill fuel tank with engine running, while smoking or when near open flame.

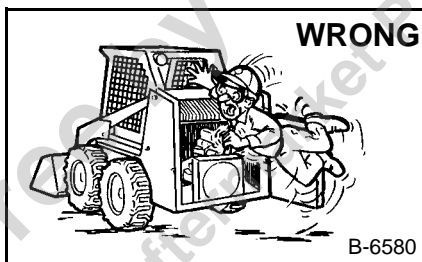

- Keep body, jewelry and clothing away from moving parts, electrical contact, hot parts and exhaust.
- Wear eye protection to guard from battery acid, compressed springs, fluids under pressure and flying debris when engines are running or tools are used. Use eye protection approved for type of welding.
- Keep rear door closed except for service. Close and latch door before operating the loader.



- Lead-acid batteries produce flammable and explosive gases.
- Keep arcs, sparks, flames and lighted tobacco away from batteries.
- Batteries contain acid which burns eyes or skin on contact. Wear protective clothing. If acid contacts body, flush well with water. For eye contact flush well and get immediate medical attention.

Maintenance procedures which are given in the Operation & Maintenance Manual can be performed by the owner/operator without any specific technical training. Maintenance procedures which are **not** in the Operation & Maintenance Manual must be performed **ONLY BY QUALIFIED BOBCAT SERVICE PERSONNEL**. Always use genuine Bobcat replacement parts. The Service Safety Training Course is available from your Bobcat dealer.



Bobcat®

Provided for Free by Frenchwell.com
Shop Aftermarket Parts

ALPHABETICAL INDEX

AIR CLEANER HOUSING	7-1	GEAR, Camshaft	7-1
ALTERNATOR	6-1	GEAR, Crankshaft	7-1
AXLE, BEARINGS AND SPROCKET	4-1	GEAR, Fuel Injection Pump Idler	7-1
		GEAR AND HUB, Idler	7-1
		GEARBOX, Fan	1-1, 7-1
BATTERY	6-1	GEARCASE, Reduction	4-1
BELT, Alternator	1-1	GEARCASE, Timing	7-1
BELT, Drive	3-1	GLOW PLUGS	7-1
BOB-TACH	5-1	GRILL, Rear	5-1
BOSS UNIT	8-1		
BRAKE, Parking	4-1	HANDLE, Steering Lever Control (Early Series)	6-1
		HOUSING, Fan Gearbox/Blower	7-1
		HYDRAULIC/HYDROSTATIC SYSTEM	1-1
CAMSHAFT	7-1	INFORMATION, Electrical System	6-1
CHAINS, Drive	4-1	INFORMATION, Hydraulic System	2-1
CHAINCASE FLUID	4-1	INFORMATION, Hydrostatic System	3-1
CODES, Monitor Service	8-1		
CONTROL, Engine Speed	7-1	LIFT ARMS	5-1
COVER, Front Chaincase	4-1	LIFT ARM SUPPORT DEVICE	1-1
COVER, Rear Chaincase	4-1	LIFTING AND BLOCKING THE LOADER	1-1
COVER, Timing Gearcase	7-1	LIFTING THE LOADER	1-1
CRANKSHAFT	7-1	LIGHTS, Front	6-1
CYLINDER, Hydraulic	2-1	LINERS, Cylinder	7-1
CYLINDER(S), Lift	2-1	LINKAGE, Pedal Interlock	2-1
CYLINDER, Tilt	2-1	LUBRICATING THE LOADER	1-1
CYLINDER, Operator Cab Gas	5-1	LUBRICATION SYSTEM	7-1
CYLINDER HEAD	7-1		
		MOTOR, Hydrostatic	3-1
DECIMAL & MILLIMETER EQUIVALENTS	9-1	MOUNTS, Engine	7-1
DOOR, Rear	5-1	MUFFLER, Engine	7-1
		MUFFLER, Spark Arrestor	1-1
ENGINE	7-1	NOZZLE, Fuel Injector	7-1
ENGINE COOLING SYSTEM	1-1		
ENGINE LUBRICATION SYSTEM	1-1	OIL COOLER	3-1
		OIL PAN	7-1
FAN, Blower	7-1	OPERATOR CAB	1-1 & 5-1
FILTER,Hydrostatic Charge Oil	3-1		
FILTER HOUSING, Hydraulic	2-1	PANEL, BOSS Instrument	8-1
FINAL DRIVE TRANSMISSION (CHAINCASE)	1-1	PANEL, Front	3-1
FLYWHEEL	7-1	PANEL, Standard Instrument	6-1
FUEL SYSTEM	1-1	PEDAL, Parking Brake	4-1
		PEDALS, Control	2-1
		PISTONS AND CONNECTING ROD	7-1
		PUMP, Hydraulic	2-1
		PUMP, Hydrostatic	3-1
		PUMP, Fuel Injection	7-1
		PUMP, Oil	7-1
		PUMP, Water	7-1
		PULLEY, Fixed Tensioner	3-1
		PULLEY, Spring Loaded Tensioner	3-1
		PULLEY, Fan Drive Tension	7-1
BOSS-BOBCAT OPERATION SENSING SYSTEM			

Cont'd On Next Page

ALPHABETICAL INDEX (Cont'd)

RADIATOR	7-1
RESERVOIR, Hydraulic Fluid	2-1
RELAY SWITCHES	6-1
REMOTE START SWITCH	1-1
ROCKER ARM AND SHAFT	7-1
SEAL, Axle	4-1
SEAT BAR RESTRAINT SYSTEM	1-1
SENDER AND SENSOR	8-1
SENSOR, RPM	8-1
SERVICE, Air Cleaner	1-1
SERVICE SCHEDULE	1-1
SHIELD, Drive Belt	3-1
SHIELD, Belt	7-1
SPECIFICATIONS, Engine	9-1
SPECIFICATIONS, Hyd./Hydr. Fluid	9-1
SPECIFICATIONS, Hydraulic Connection	9-1
SPECIFICATIONS, Loader	9-1
STARTER	6-1
STEERING LEVERS	3-1
TANK, Coolant Recovery	7-1
TANK, Fuel	5-1
TIRE MAINTENANCE	1-1
THERMOSTAT	7-1
TROUBLESHOOTING	2-1, 3-1, 6-1, 7-1, 8-1
TOOL, BOSS Diagnostic	8-1
TORQUE, Loader	9-1
TORQUE, Specifications For Bolts	9-1
TOWING THE LOADER	1-1
TRANSPORTING THE LOADER	1-1
U.S. TO METRIC CONVERSION	9-1
VALVE, Bucket Position	2-1
VALVE CLEARANCE	7-1
VALVE, Cold Oil By-Pass	3-1
VALVE, Dual Pressure Main Relief	2-1
VALVE, Front Auxiliary Control (Apitech)	2-1
VALVE, Hydraulic Control	2-1
VALVE, Lock	2-1
VALVE, Main Relief	2-1
VALVE, Select (JEM)	2-1
VALVES, VALVE SEAT AND GUIDE	7-1
WATER JACKET TUBE	7-1

CONTENTS

FOREWORD	ii
SAFETY INSTRUCTIONS	v
SERIAL NUMBER LOCATIONS	vii
DELIVERY REPORT	vii
BOBCAT LOADER IDENTIFICATION	viii
PREVENTIVE MAINTENANCE	1-1
HYDRAULIC SYSTEM	2-1
HYDROSTATIC SYSTEM	3-1
DRIVE SYSTEM	4-1
MAIN FRAME	5-1
ELECTRICAL SYSTEM	6-1
ENGINE SERVICE	7-1
SYSTEM ANALYSIS	8-1
SPECIFICATIONS	9-1

Component Repair Manual

A Component Repair Manual is available for this model Bobcat loader.

A component Repair Manual gives complete teardown procedures for service and repair of all major components such as control valves, hydrostatic pumps and motors, hydraulic pumps, etc.

See your Bobcat dealer about availability of this important addition to your service library.

CALIFORNIA PROPOSITION 65 WARNING

Diesel engine exhaust and some of its constituents are known to the State of California to cause cancer, birth defects and other reproductive harm.

**PREVENTIVE
MAINTENANCE**

**HYDRAULIC
SYSTEM**

**HYDROSTATIC
SYSTEM**

**DRIVE
SYSTEM**

**MAIN
FRAME**

**ELECTRICAL
SYSTEM**

**ENGINE
SERVICE**







**SYSTEMS
ANALYSIS**

SPECIFICATIONS

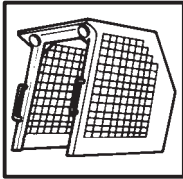
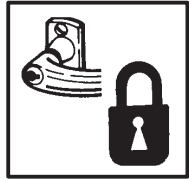
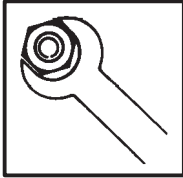
FOREWORD

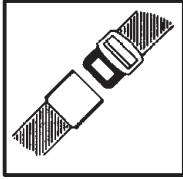
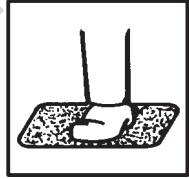
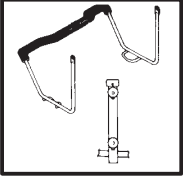
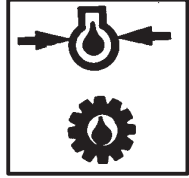
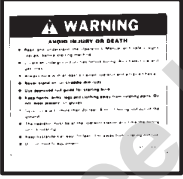
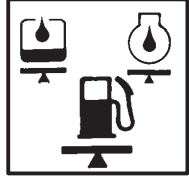
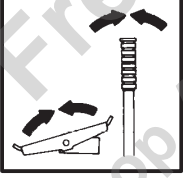
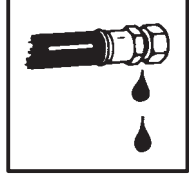
This manual is for the Bobcat loader mechanic. It provides necessary servicing and adjustment procedures for the Bobcat loader and its component parts and systems. Refer to the Operation & Maintenance Manual for operating instructions, starting procedure, daily checks, etc.

A general inspection of the following items must be made after the loader has had service or repair:

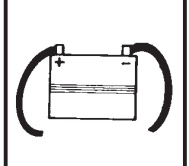
- | | | | |
|---|---|--|---|
| 1. Check that the ROPS/FOPS (Including sidescreens) is in good condition and is not modified. |  | 9. Enclosure door latches must open and close freely. |  |
| 2. Check that ROPS mounting hardware is tightened and is Melroe approved. |  | 10. Bob-Tach wedges and linkages must function correctly and be in good condition. |  |
| 3. The seat belt must be correctly installed, functional and in good condition. |  | 11. Safety treads must in good condition. |  |
| 4. The seat bar and pedal interlocks must be correctly adjusted, clean and lubricated. |  | 12. Check for correct function of indicator lamps (Optional on some models). |  |
| 5. Machine signs must be legible and in the correct location. |  | 13. Check hydraulic fluid level, engine oil level and fuel supply. |  |
| 6. Steering levers and foot pedals must return to neutral. |  | 14. Inspect for fuel, oil or hydraulic fluid leaks. |  |
| 7. Check for correct function of the work lights. |  | 15. Lubricate the loader. |  |
| 8. The parking brake must function correctly. |  | 16. Check the condition of the battery and cables. |  |

17. Inspect the air cleaner for damage or leaks. Check the condition of the element.

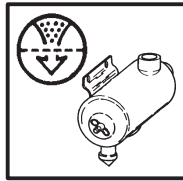

18. Check the electrical charging system.

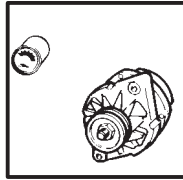

19. Check tires for wear and pressure.

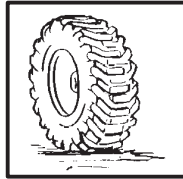

20. Inspect for loose or broken parts or connections.

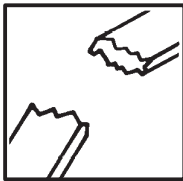

21. Operate the loader and check all functions.

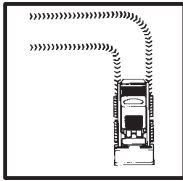

22. Check for any field modification not completed.



23. Check for correct function of the Bobcat Interlock Control System (BICS™) before the machine is returned to the customer.

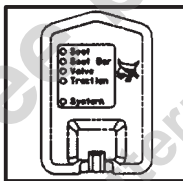

Recommend to the owner that all necessary corrections be made before the machine is returned to service.





Provided for Free by www.youfixthis.com
Shop Aftermarket Parts at www.frenchwell.com

SAFETY INSTRUCTIONS



WARNING

Instructions are necessary before operating or servicing machine. Read and understand the Operation & Maintenance Manual, Handbook and signs (decals) on machine. Follow warnings and instructions in the manuals when making repairs, adjustments or servicing. Check for correct function after adjustments, repairs or service. Untrained operators and failure to follow instructions can cause injury or death.

W-2003-0299

The following publications provide information on the safe use and maintenance of the loader and attachments:

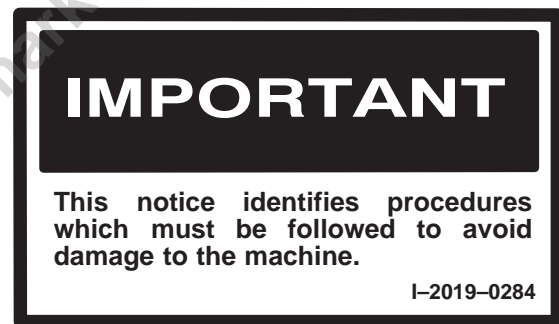
- The Delivery Report is used to assure that complete instructions have been given to the new owner and that the machine is in safe operating condition.
- The Operation & Maintenance Manual delivered with the loader gives operating information as well as routine maintenance and service procedures. It is a part of the loader and must stay with the machine when it is sold. Replacement Operation & Maintenance Manuals can be ordered from your Bobcat loader dealer.
- The loader has machine signs (decals) which instruct on the safe operation and care. The signs and their locations are shown in the Operation & Maintenance Manual. Replacement signs are available from your Bobcat loader dealer.
- The loader has a plastic Operator's Handbook fastened to the operator cab. Its brief instructions are convenient to the operator. The Handbook is available from your dealer in an English edition or one of many other languages. See your Bobcat dealer for more information on translated versions.
- The EMI Safety Manual (available in Spanish) delivered with the loader gives general safety information.
- The Service Manual and Parts Manual are available from your dealer for use by mechanics to do shop-type service and repair work.
- The Skid-Steer Loader Operator Training Course is available through your local dealer. This course is intended to provide rules and practices for correct operation of the Bobcat loader. The course is available in English and Spanish version.
- The Service Safety Training Course is available from your Bobcat dealer. This course provides information for safe and correct service procedures for Bobcat Skid-Steer loaders.
- The Bobcat Skid-Steer Loader Safety Video is available from your Bobcat Dealer.



Safety Alert Symbol: This symbol with a warning statement, means: "Warning, be alert! Your safety is involved!" Carefully read the message that follows.

SAFETY INSTRUCTIONS (Cont'd)

- Wear tight fitting clothing. Always wear safety glasses when maintaining or servicing loader. Safety glasses, hearing protection or loader special applications kit are required for some work. See your dealer for Melroe Safety equipment.
- Know where fire extinguisher and first aid kit are located and how to use them.
- Do not use the Bobcat loader where exhaust, arcs, sparks or hot components can contact flammable material, explosive dust or gases.
- The engine compartment and engine cooling system must be inspected every day and cleaned if necessary to prevent fire hazard and overheating.
- Check all electrical wiring and connections for damage. Keep the battery terminals clean and tight. Repair or replace any damaged part.
- Check fuel and hydraulic tubes, hoses and fittings for damage and leakage. Never use open flame or bare skin to check for leaks. Tighten or replace any parts that show leakage. Always clean fluid spills. Do not use gasoline or diesel fuel for cleaning parts. Use commercial nonflammable solvents.
- Follow any environmental safety regulations when disposing of used fluids such as engine oil, grease or anti-freeze.
- Do not use ether or starting fluids on engines which have glow plugs. These starting aids can cause explosion and injure you or bystanders.
- Always clean the loader and disconnect the battery before doing any welding. Cover rubber hoses, battery and all other flammable parts. Keep a fire extinguisher near the loader when welding. Have good ventilation when grinding or welding painted parts. Wear dust mask when grinding painted parts. Toxic dust or gas can be produced.
- Stop the engine and let it cool before adding fuel. No smoking!
- Use the procedure in the Operation & Maintenance or Service Manuals for connecting the battery.

A fire extinguisher is available from your local dealer. The fire extinguisher can be installed in the location shown [A].



SERIAL NUMBER LOCATIONS

Always use the serial number of the loader when requesting service information or when ordering parts. Early or later models (identification made by serial number) may use different parts, or it may be necessary to use a different procedure in doing a specific service operation.

LOADER SERIAL NUMBER

The loader serial number plate is located on the inside of the left upright, above the grill [A].

Explanation of loader Serial Number:

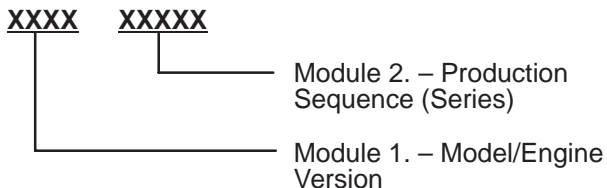

The four digit Model/Engine Combination module number identifies the model number and engine combination. This number (in parenthesis beside the model number) is used in the Service Manual to more easily identify the standard, optional and field accessory equipment included or available for each specific model.

The five digit Production Sequence Number identifies the order which the loader is produced.

ENGINE SERIAL NUMBER

The serial number is located above the starter on the engine block [B].

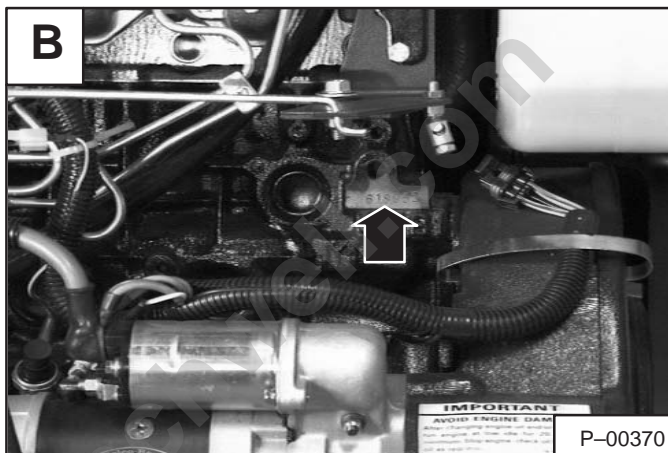

DELIVERY REPORT

The Delivery Report must be filled out by the dealer and signed by the owner or operator when the Bobcat loader is delivered. An explanation of the form must be given to the owner. Make sure it is filled out completely [C].

BOBCAT LOADER IDENTIFICATION

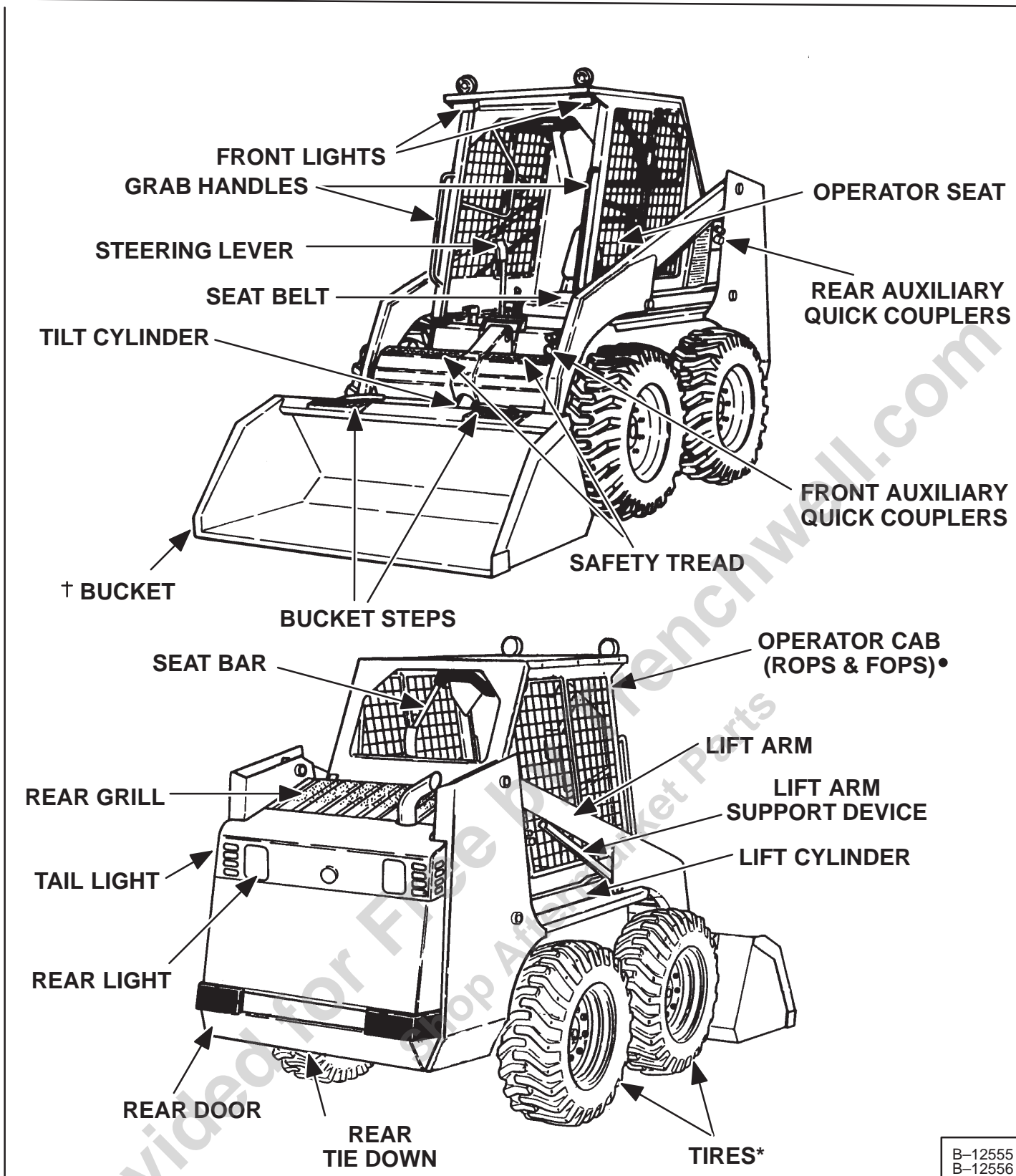

B-12555
B-12556

* TIRES - Flotation tires are shown. The Bobcat loader is base-equipped with standard tires.

† BUCKET - Several different buckets and other attachments are available for the Bobcat loader.

• ROPS, FOPS - Roll Over Protective Structure, per SAE J1040 and ISO 3471 and Falling Object Protective Structure per SAE J1043 and ISO 3449 Level I. Level II FOPS is available for protection from heavy falling objects. The Bobcat loader is base-equipped with a standard operator cab as shown. Extra insulated cab is available as an option (Reduced noise level).

PREVENTIVE MAINTENANCE**PREVENTIVE
MAINTENANCE**

	Page Number
AIR CLEANER SERVICE	
Replacing Filter Element	1-12
ALTERNATOR BELT	
Adjusting The Alternator Belt	1-20
ENGINE COOLING SYSTEM	
Cleaning The Cooling System	1-18
Checking The Coolant Level	1-18
Removing Coolant From The Cooling System	1-19
ENGINE LUBRICATION SYSTEM	
Checking Engine Oil	1-16
Replacing Oil And Filter	1-16
FAN GEARBOX	
Checking And Maintaining	1-26
FINAL DRIVE TRANSMISSION (CHAINCASE)	
Checking And Adding Oil	1-26
FUEL SYSTEM	
Filling The Fuel Tank	1-14
Fuel Filter	1-14
Fuel Specifications	1-14
Removing Air From The Fuel System	1-15
HYDRAULIC/HYDROSTATIC SYSTEM	
Checking And Adding Fluid	1-21
Replacing Hydraulic/Hydrostatic Filters	1-21
Hydraulic Reservoir Breather Cap	1-23
Replacing Hydraulic Fluid	1-22
LIFT ARM SUPPORT DEVICE	
Engaging The Lift Arm Support Device	1-7
Disengaging The Lift Arm Support Device	1-8
LIFTING AND BLOCKING THE LOADER	
Procedure	1-4
LIFTING THE LOADER	
Four Point Lift	1-6
Single Point Lift	1-6
LUBRICATING THE LOADER	
Procedure	1-27
OPERATOR CAB	
Description	1-9
Lowering The Operator Cab	1-10
Raising The Operator Cab	1-9
Emergency Exit	1-10

PREVENTIVE MAINTENANCE (Cont'd)

	Page Number
REMOTE START SWITCH	
Procedure	1-29
SEAT BAR RESTRAINT SYSTEM	
Description	1-11
Seat Bar Inspection	1-11
Seat Bar Maintenance	1-11
SERVICE SCHEDULE	
Chart	1-3
SPARK ARRESTOR MUFFLER	
Cleaning Procedure	1-24
TIRE MAINTENANCE	
Tire Mounting	1-25
Tire Rotation	1-25
Wheel Nuts	1-25
TOWING THE LOADER	
Procedure	1-5
TRANSPORTING THE LOADER	
Procedure	1-5

SERVICE SCHEDULE

Maintenance work must be done at regular intervals. Failure to do so will result in excessive wear and early failures. The service schedule is a guide for correct maintenance of the Bobcat loader.



WARNING

Instructions are necessary before operating or servicing machine. Read and understand the Operation Maintenance Manual, Handbook and signs (decals) on machine. Follow warnings and instructions in the manual when making repairs, adjustments or servicing. Check for correct function after adjustments, repairs or service. Untrained operators and failure to follow instructions can cause injury or death.

W-2003-0199

SERVICE SCHEDULE		HOURS				
ITEM	SERVICE REQUIRED	8-10	50	100	250	1000
Engine Oil	Check the oil level and add oil as needed.					
Air Cleaner	Check condition indicator or display panel. Service only when required.					
Engine Cooling System	Clean debris from oil cooler, radiator and grill. Check coolant level cold in recovery tank. See Page 1-18 for correct coolant mixture.					
Lift Arms, Cyl., Bob-Tach Pivot Pins & Wedges	Lubricate with multi-purpose lithium based grease (12 places).					
Engine Air System	Check for leaks and damaged components.					
Tires	Check for damaged tires and correct air pressure.					
Seat Belt, Seat Bar & Pedal Interlocks	Check the condition of seat belt. Check the seat bar and pedal interlocks for correct operation. Clean dirt and debris from moving parts.					
Safety Signs & Safety Tread	Check for damaged signs (decals) and safety tread. Replace any signs or safety treads that are damaged or worn.					
Operator Cab	Check the fastening bolts, washers and nuts. Check the condition of cab.					
Fuel Filter	Remove the trapped water.					
Hydraulic Fluid, Hoses & Tubelines	Check fluid level and add as needed. Check for damage and leaks. Repair and replace as needed.					
Final Drive Transmission (Chaincase)	Check oil level.					
Battery	Check cables and electrolyte level.					
Control Pedals & Steering	Check for correct operation. Repair or adjust as needed.					
Wheel Nuts	<input type="checkbox"/> Check for loose wheel nuts and tighten to 105-115 ft.-lbs. (142-156 Nm) torque.					
Parking Brake	Check operation.					
Alternator Belt	Check tension and adjust as needed.					
Engine Oil & Filter	Replace oil and filter.					
Spark Arrestor Muffler	Clean the spark chamber.					
Engine/Hydro. Drive Belt	* Check for wear or damage. Adjust as needed.					
Fuel Filter	Replace filter element.					
Seat Bar	Grease pivots as needed.					
Steering Shaft	Grease three fittings.					
Hyd./Hydro. Filter	• Replace the filter element.					
Hydraulic Reservoir Breather Cap	Replace the reservoir breather cap.					
Fan Drive Gearbox	Check gear lube level.					
Final Drive Transmission	Replace the oil in the chaincase.					
Hydraulic Reservoir	Replace the fluid.					
Hydraulic Motors	† Replace the two case drain filters.					

Check wheel nut torque every 8 hours for the first 24 hours.

• Also replace hydraulic/hydrostatic filter element when the transmission warning light comes ON.

■ Or every 12 months.

* Inspect the new belt after first 50 hours.

† Clean or replace case drain filters in the event of any major hydraulic or hydrostatic repair.



WARNING

Instructions are necessary before operating or servicing machine. Read and understand the Operation & Maintenance Manuals, Handbook and signs (decals) on machine. Follow warnings and instructions in the manuals when making repairs, adjustments or servicing. Check for correct function after adjustments, repairs or service. Untrained operators and failure to follow instructions can cause injury or death.

W-2003-0199

Read the *Removal & Installation, Disassembly & Assembly*, etc. completely to become familiar with the procedure before beginning [A].

LIFTING AND BLOCKING THE LOADER

Procedure

Always park the loader on a level surface.



WARNING

Put jackstands under the front axles and rear corners of the frame before running the engine for service. Failure to use jackstands can allow the machine to fall or move and cause injury or death.

W-2017-0286

Put floor jack under the rear of the loader [B].

Lift the rear of the loader and install jackstands [B].

Put the floor jack under the front the loader [C].

Lift the front of the loader and put jackstands under the axle tubes [C].

NOTE: Make sure the jackstands do not touch the tires.

A



B-07023

B



CD-11160

C

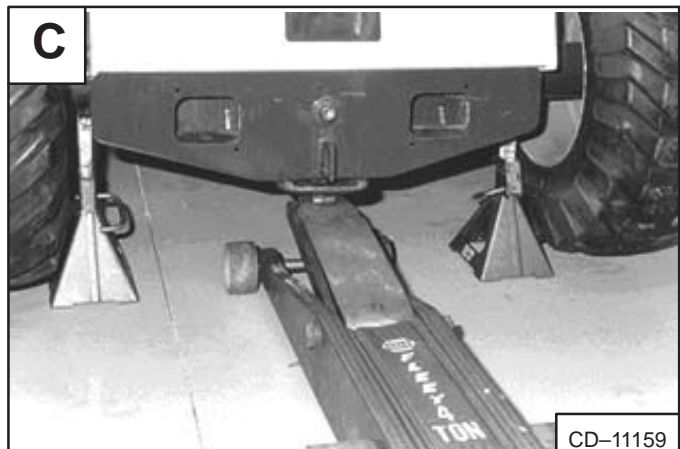

CD-11159

TRANSPORTING THE LOADER

Procedure

! WARNING

Adequately designed ramps of sufficient strength are needed to support the weight of the machine when loading onto a transport vehicle. Wood ramps can break and cause personal injury.

W-2058-0494

The rear of the transport vehicle must be blocked or supported when loading or un-loading the loader.

A loader with an empty bucket or no attachment must be loaded backward onto the transport vehicle [A].

Be sure the transport and towing vehicles are of adequate size and capacity.

Use the following procedure to fasten the Bobcat loader to the transport vehicle to prevent the loader from moving during sudden stops or when going up or down slopes [B].

Lower the bucket or attachment to the floor. Stop the engine. Engage the parking brake. Install chains at the front and rear loader tie down positions (Inset) [B]. Fasten each end of the chain to the transport vehicle and tighten the chain with a chain tightener.

TOWING THE LOADER

Procedure

To prevent damage to the loader's hydrostatic system, the loader must be towed only a short distance at slow speed. (Example: Moving the loader onto a transport vehicle.)

The towing chain (or cable) must be rated at 1-1/2 times the weight of the loader. (See *Specification* Page 9-1.)

- Disengage the parking brake.
- Tow the Bobcat at 2 MPH (3,2 km/hr.) or less for not more than 25 feet (7,6 meters).

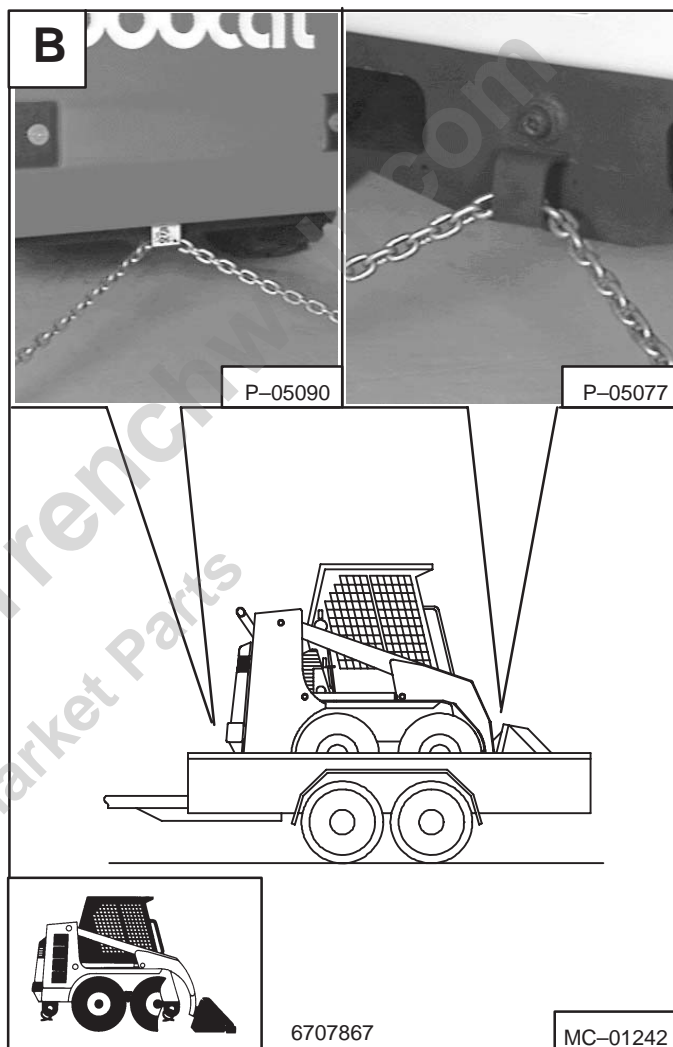
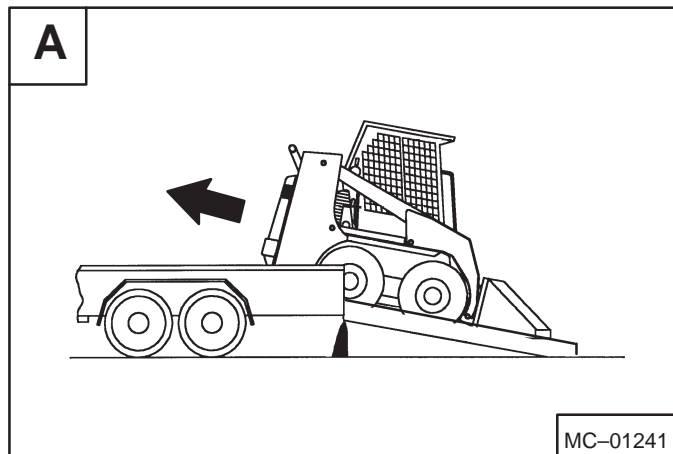

LIFTING THE LOADER**Four Point Lift****WARNING****AVOID INJURY OR DEATH**

- Before lifting, check fasteners on four point lift.
- Never allow riders in the cab or bystanders within 15 feet (5 meters) while lifting the machine.

W-2046-1290

The loader can be lifted with the four point lift which is available as a kit from your Bobcat loader dealer.

Attach cables or chains to lift eyes as shown [A].

Single Point Lift**WARNING****AVOID INJURY OR DEATH**

- Before lifting, check fasteners on single point lift and operator cab.
- Assemble front cab fasteners as shown in manual.
- Never allow riders in the cab or bystanders within 15 feet (5 meters) while lifting the machine.

W-2007-1285

The loader can also be lifted with the single point lift which is available as a kit from your Bobcat loader dealer.

Install the kit and lift as shown [B].

The single point lift, supplied by Melroe Company is designed to lift and support the Bobcat loader without affecting roll over and falling object protection features of the operator cab.

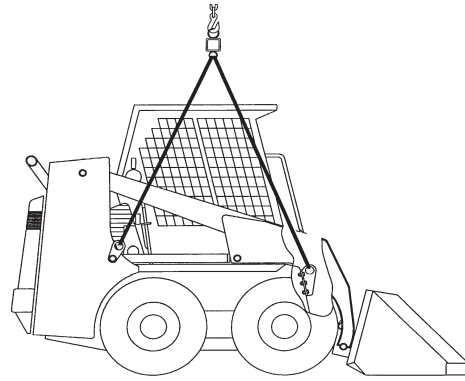
A

MC-01434

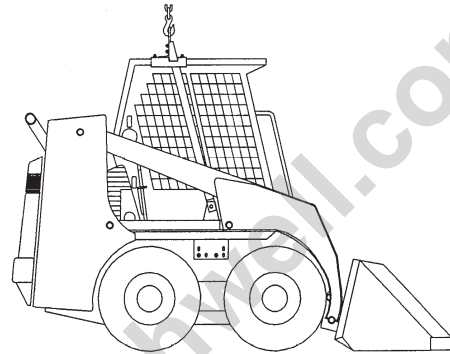
B

MC-01664

LIFT ARM SUPPORT DEVICE

! WARNING

Never work on a machine with the lift arms up unless the lift arms are secured by a lift arm support device. Failure to use an approved lift arm support device can allow the lift arms or attachment to fall and cause injury or death.

W-2059-0991

Engaging the Lift Arm Support Device

Maintenance and service work can be done with the lift arms lowered.

If the lift arms must be raised for service, use the following procedure:

Put jackstands under the rear corners of the loader.

Disconnect the spring (Item 1) [A] from the lift arm support device retaining pin (Item 2) [A]. Hold onto the lift arm support device and remove the retaining pin.

Lower the lift arm support device on top of the lift cylinder. Hook the free end of the spring (Item 1) [B] to the lift arm support device so there will be no interference with the support device engagement.

With the operator in the seat, seat belt fastened and seat bar lowered, start the engine.

Raise the lift arms, until the lift arm support device drops onto the lift cylinder rod [C].

Lower the lift arms slowly until the support device is held between the lift arm and the lift cylinder. Stop the engine. Raise the seat and move pedals until both pedals lock.

Install pin (Item 1) [C] into the rear of the lift arm support device below the cylinder rod.

! WARNING

Service lift arm support device if damaged or if parts are missing. Using a damaged lift arm support or with missing parts can cause lift arms to drop causing injury or death.

W-2271-1197

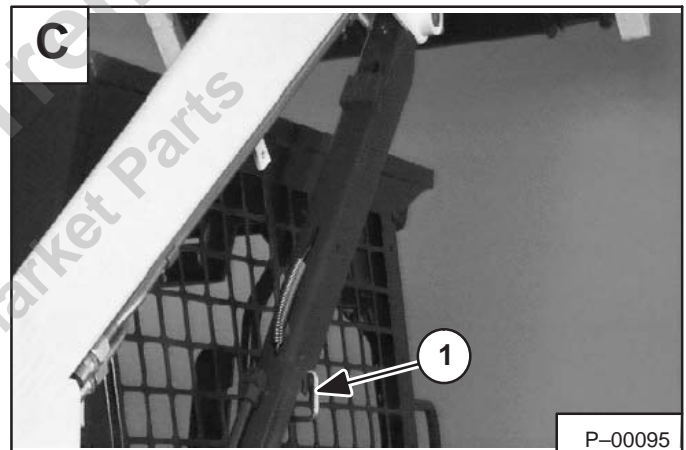
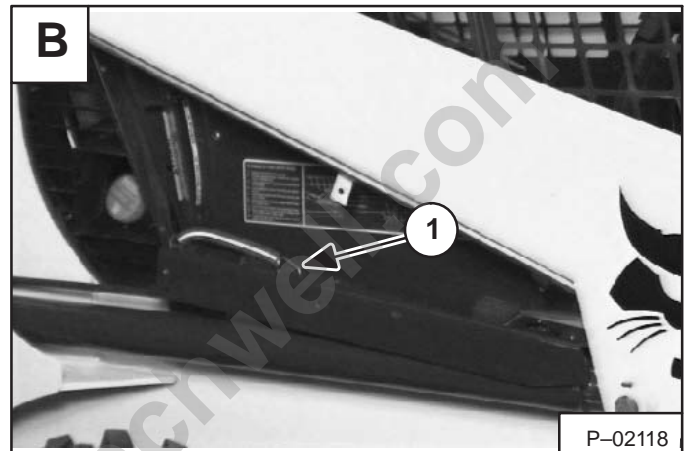
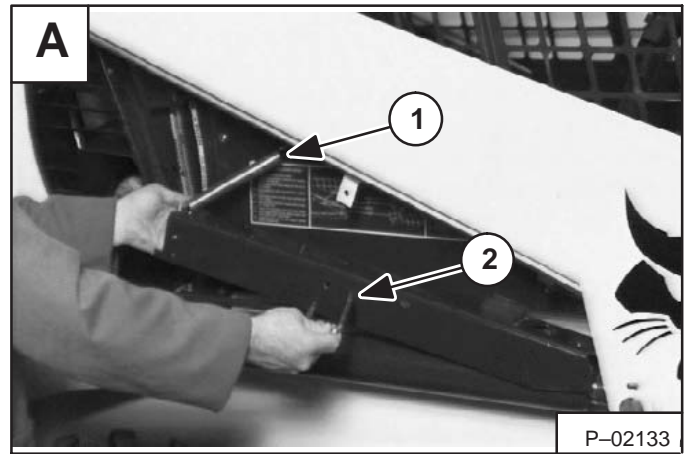

LIFT ARM SUPPORT DEVICE (Cont'd)

Disengaging The Lift Arm Support Device

Remove the pin from the lift arm support device.

Connect the spring (Item 1) **[A]** from the lift arm support device to the bracket below the lift arms.

With the operator in the seat, seat belt fastened and seat bar lowered, start the engine.

Raise the lift arms a small amount and the spring will lift the support device off the lift cylinder rod.

Lower the lift arms. Stop the engine.

Raise the seat bar and move pedals until both pedals lock.

Disconnect the spring from the bracket.

Raise the support device into storage position and insert pin through lift arm support device and bracket **[B]**.

Connect spring to pin.

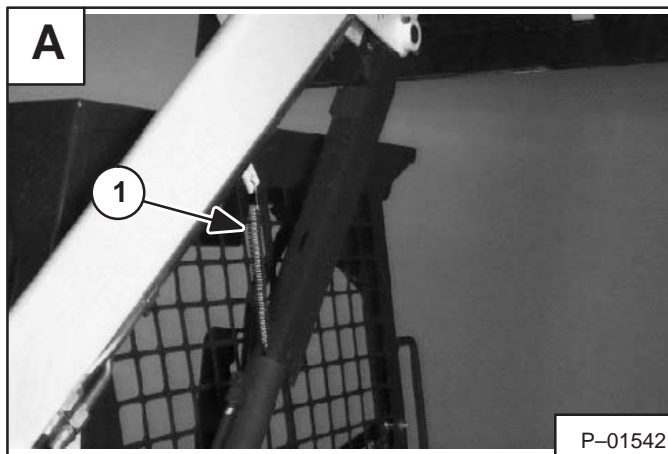

OPERATOR CAB

Description

The Bobcat loader has an operator cab (ROPS and FOPS) as standard equipment to protect the operator from rollover and falling objects. Check with your dealer if the operator cab has been damaged. The seat belt must be worn for roll over protection.

ROPS/FOPS Roll Over Protective Structure per SAE J104 and ISO 3471, and Falling Object Protective Structure per SAE J1043 and ISO 3449, Level I. Level II is available.

Level I – Protection from falling bricks, small concrete blocks and hand tools encountered in operations such as highway maintenance, landscaping, and other construction site services.

Level II – Protection from falling trees, rocks; for machines involved in site clearing, overhead demolition or forestry.



WARNING

Never modify operator cab by welding, grinding, drilling holes or adding attachments unless instructed to do so by Melroe Company. Changes to the cab can cause loss of operator protection from rollover and falling objects, and result in injury or death.

W-2069-1285

Raising The Operator Cab

Stop the loader on a level surface. Lower the lift arms. If the lift arms must be up while raising the operator cab, install the lift arm support device. (See Page 1-7.)

Loosen the nut (Item 1) [A] (both sides) at the front corner of the operator cab.

Remove the nut and plate (both sides) [B].

Lift on the grab handle and bottom of the operator cab slowly until the cab latching mechanism engages and the cab is all the way up [C].

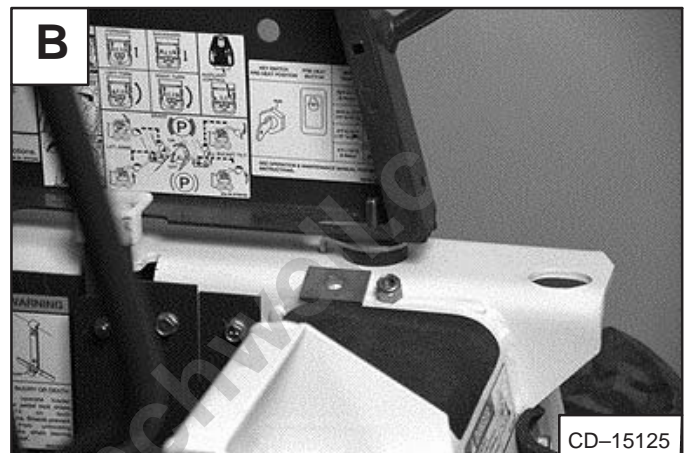
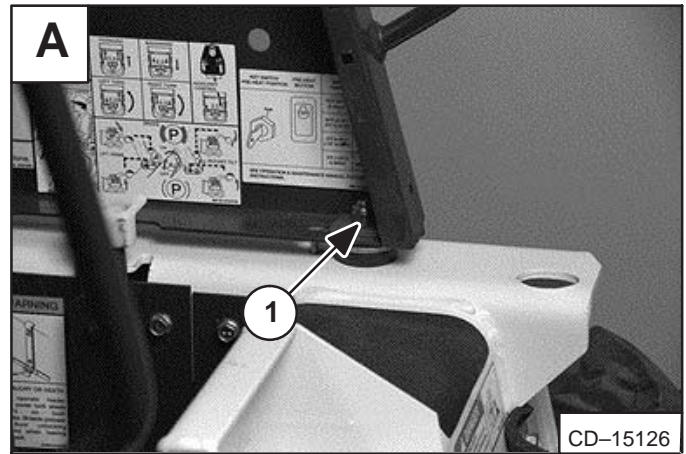

WARNING

Before the cab or the lift arms are raised for service, jackstands must be put under the rear corners of the frame. Failure to use jackstands may allow the machine to tip backward causing injury or death.

W-2014-1285

OPERATOR CAB (Cont'd)**Lowering The Operator Cab**

NOTE: Make sure the seat bar is fully raised or lowered when lowering the cab.

Pull down on the bottom of the operator cab until it stops at the latching mechanism.

Release the latching mechanism (Item 1) [A] and pull the cab all the way down.

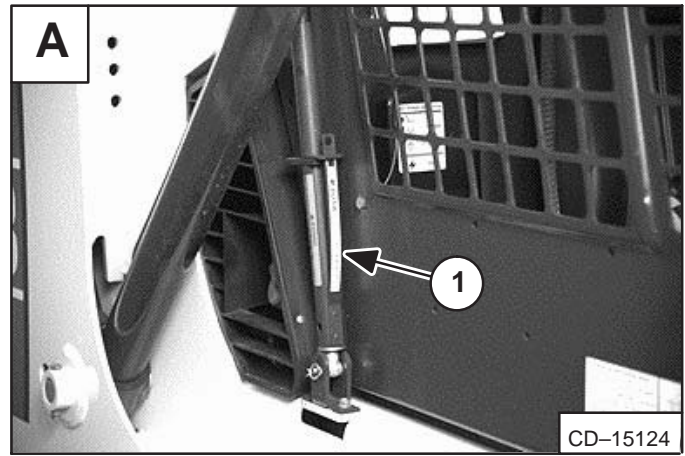

Install the plate and nut (Item 1) [B] (both sides).

Tighten the nuts to 40–50 ft.-lbs. (54–68 Nm) torque [B].

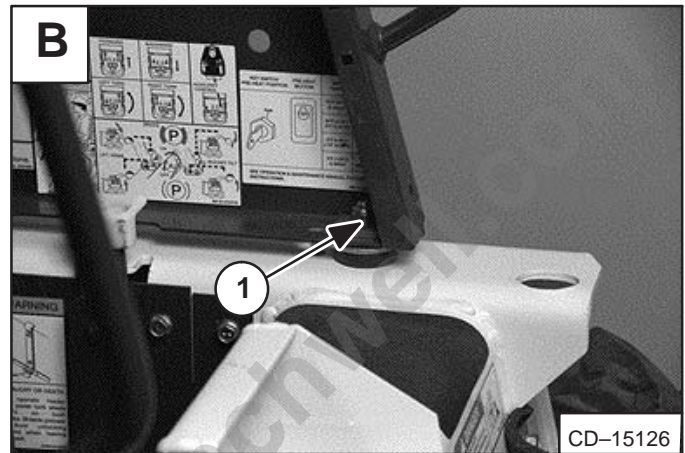
**Emergency Exit**

The front opening on the operator cab and rear window provide exits.

To exit through the rear window, use the following procedure:

Pull on the tag on the top of the rear window to remove the rubber cord [C].



Push the rear window out of the rear of the operator cab.

Exit through the rear of the operator cab [D].



SEAT BAR RESTRAINT SYSTEM

Description

The seat bar restraint system has a pivoting seat bar with arm rests and has spring loaded interlocks for the lift and tilt control pedals.

The operator controls the use of the seat bar. The seat bar in the down position helps to keep the operator in the seat.

The interlocks require the operator to lower the seat bar in order to operate the foot pedal.

When the seat bar is up, the lift and tilt pedals are locked when returned to the NEUTRAL POSITION.

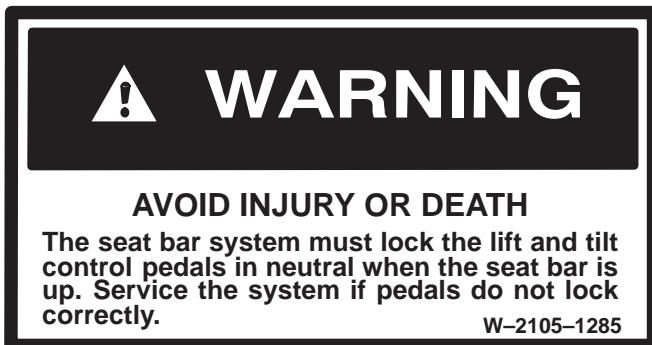

Inspecting The Seat Bar

Sit in the seat and fasten the seat belt. Engage the parking brake. Pull the seat bar all the way down. Start the engine. Operate each foot pedal to check both the lift and tilt functions. Raise the lift arms until the bucket is about 2 feet (600 mm) off the ground.

Raise the seat bar. Try to move each foot pedal. Pedals must be firmly locked in neutral position. There must be no motion of the lift arms or tilt (bucket) when the pedals are pushed.

Pull the seat bar down, lower the lift arms. Operate the lift pedals. While the lift arms are going up, raise the seat bar and the lift arms should stop.

Lower the seat bar, lower the lift arms and place the bucket flat on the ground. Stop the engine. Raise the seat bar and operate the foot pedals to be sure that the pedals are firmly locked in the neutral position. Unbuckle the seat belt.

Maintaining The Seat Bar

See the *SERVICE SCHEDULE*, Page 1-3 for correct service interval.

Clean any debris or dirt from the moving parts [A] & [B]. Inspect the linkage bolts and nuts for tightness. The correct torque is 25-28 ft.-lbs. (34-38 Nm).

Use a general purpose grease to lubricate the seat bar pivot points at each side of the cab [A].

If the seat bar system does not function correctly, check for free movement of each linkage part. Check for excessive wear. Adjust pedal control linkage.

Replace parts that are worn or damaged. Use only genuine Melroe replacement parts.

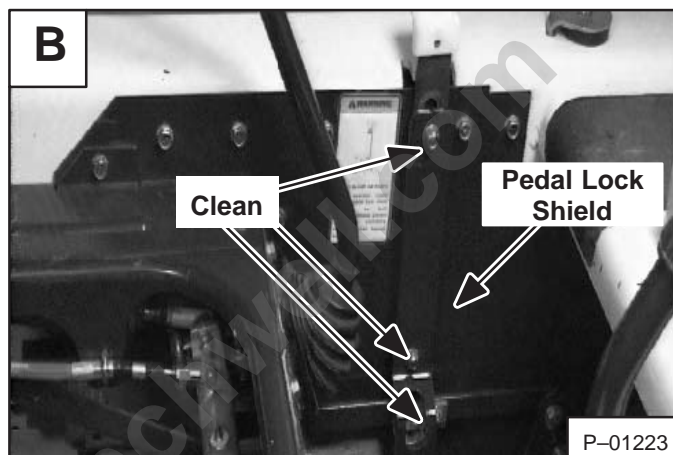
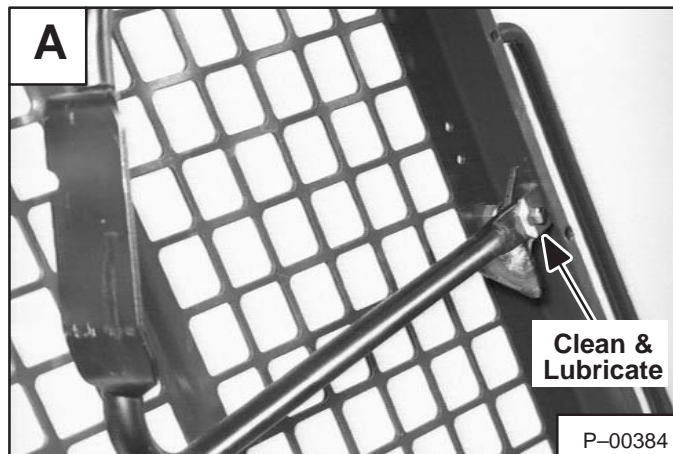

AIR CLEANER SERVICE

Replacing Filter Element

See the *SERVICE SCHEDULE*, Page 1–3 for the interval to service the air cleaner system.

WITH CONDITION INDICATOR: Replace the large (outer) filter element only when the red ring shows in the window of the condition indicator (Item 1) [A].

NOTE: Before replacing the filter element, push the button on the condition indicator (Item 2) [A]. Start the engine. If the red ring does not show, do not replace the filter element.

Replace the inner filter every third time the outer filter is replaced or when the red ring still shows in the indicator window after the outer filter has been replaced.

WITH BOSS® OPTION: It is important to change the air filter element only when the service codes (on the BOSS® option instrument panel) shows the symbols [AF.2] [B].

Service the air cleaner as follows:

Remove the dust cover wing nut (Item 1) [C].

Remove the dust cover.

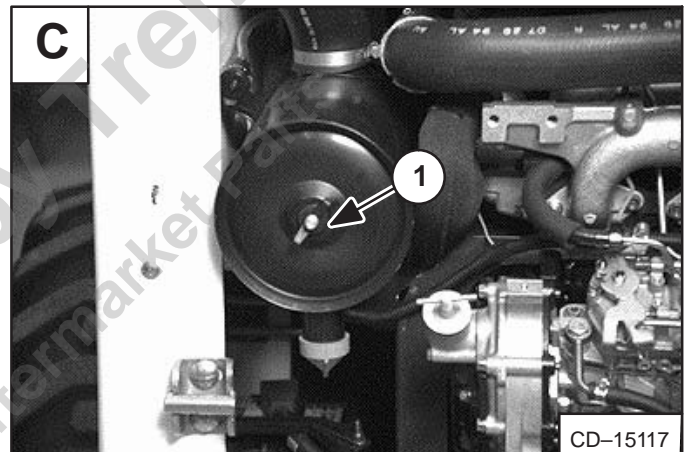
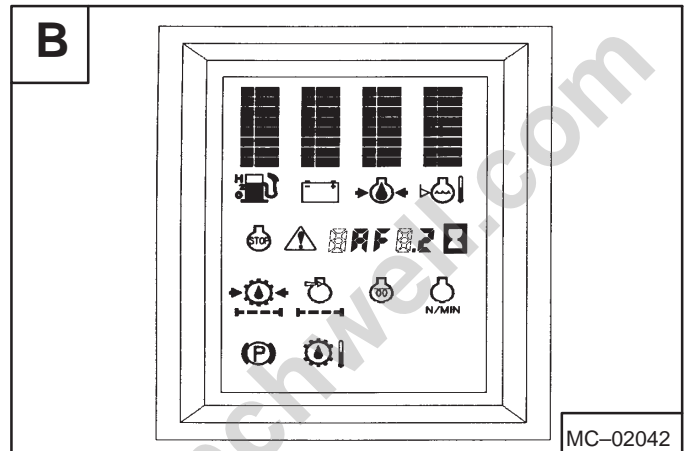
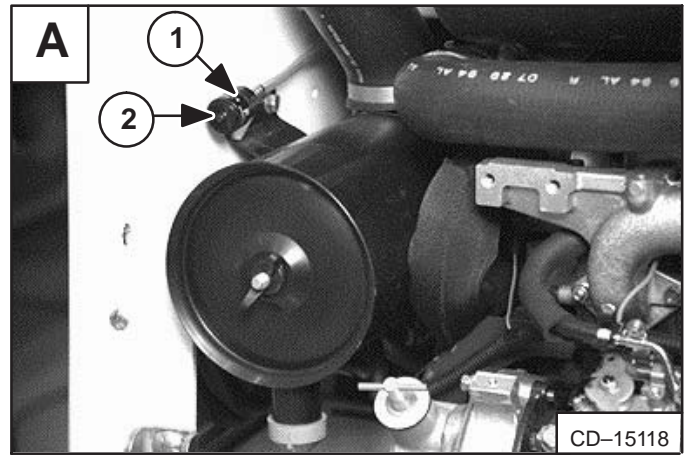

AIR CLEANER SERVICE (Cont'd)**Replacing Filter Element (Cont'd)**

Remove the wing nut (Item 1) [A] at the large air filter element.

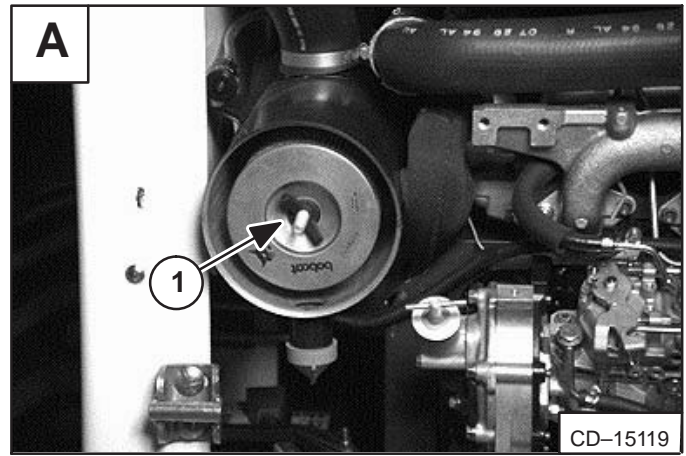

CD-15119

Remove the large filter element [B].

NOTE: Make sure all sealing surfaces are free of dirt and debris.

Install the new filter element and washer and tighten the wing nut.

Check the air intake hose for damage. Check the air cleaner housing for damage. Check to make sure all connections are tight.

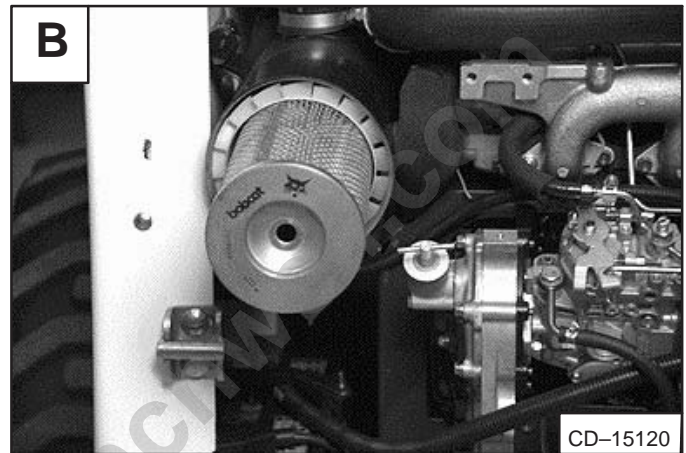

CD-15120

Inner Filter Element:

Only replace the inner filter element under the following conditions:

1. Replace the inner filter element every third time the outer filter is replaced.
2. If the service codes show symbols, Page 8-1, during full engine speed, replace the inner filter element only after the outer filter element has been changed.

Remove the inner filter wing nut (Item 1) [C] to remove the filter element.

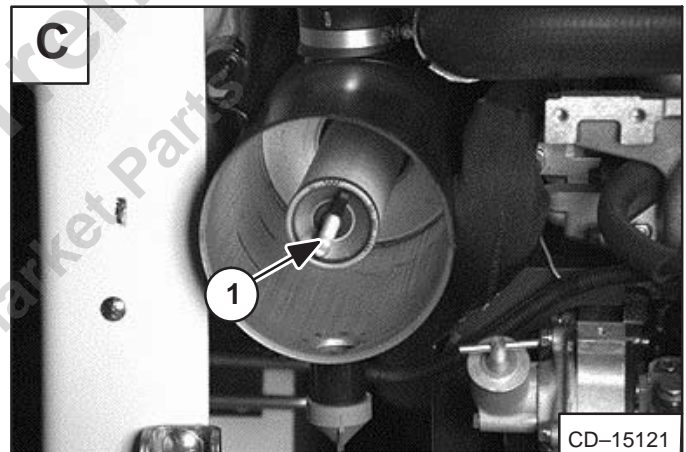

CD-15121

FUEL SYSTEM

Fuel Specifications

Use only clean, high quality diesel fuel, Grade No. 1 or Grade No. 2 .

The following is one suggested blending guideline which should prevent fuel gelling problems:

Temp. F° (C°)	No. 2	No.1
+15°(9°)	100%	0%
Down to -20° (-29°)	50%	50%
Below -20° (29°)	0%	100%

We recommend an operator contact their fuel supplier for local recommendations.

Filling The Fuel Tank



Remove the fuel fill cap (Item 1) [A].

Use a clean, approved safety container to add fuel of the correct specifications. Add fuel only in an area that has free movement of air and no open flames or sparks. **NO SMOKING!** [B].

Install and tighten the fuel fill cap [A].

Fuel Filter

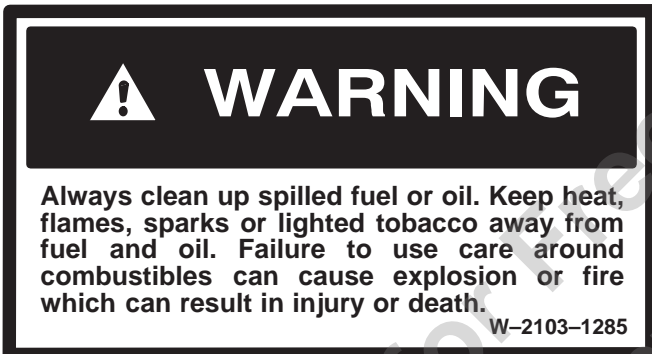

See the *SERVICE SCHEDULE*, Page 1-3 for the service interval when to remove the water from the fuel filter.

Loosen the drain (Item 1) [C] at the bottom of the filter element to drain any water from the filter.

See the *SERVICE SCHEDULE*, Page 1-3 for the service interval when to replace the fuel filter.

To replace the fuel filter element (Item 2) [C], use a filter wrench to remove the filter element.

Clean the area around the filter housing. Put oil on the seal of the new filter element. Install the fuel filter, and hand tighten. Remove the air from the fuel system. (See Page 1-15.)

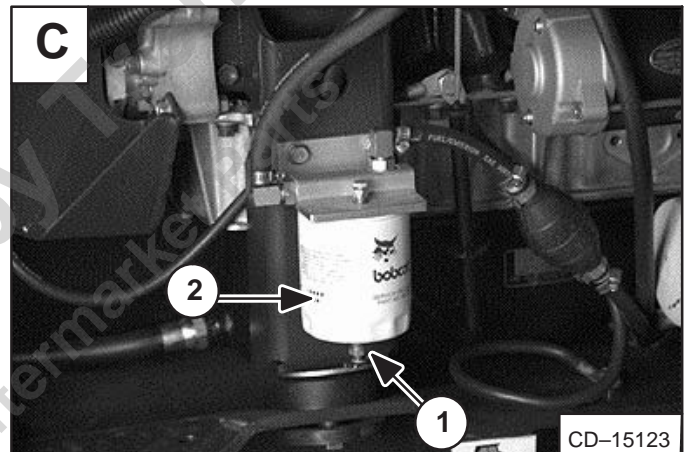
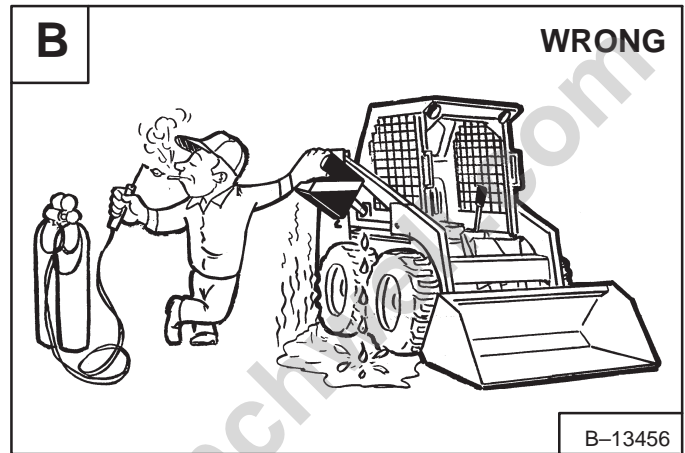
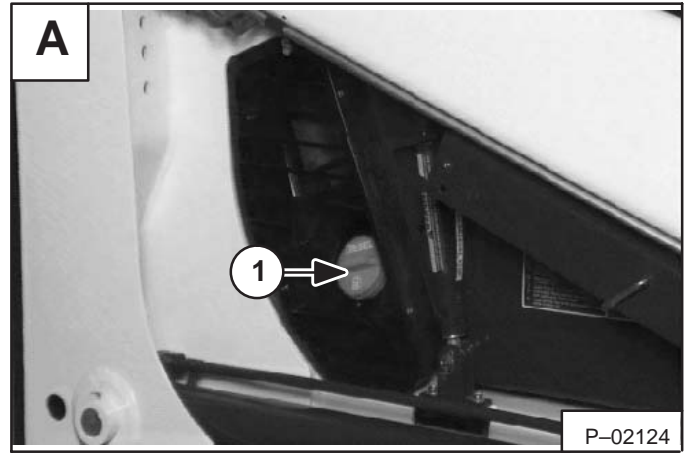

FUEL SYSTEM (Cont'd)**Removing Air From The Fuel System**

After replacing the fuel filter element or when the fuel tank has run out of fuel, the air must be removed from the fuel system prior to starting the engine.

Loosen the air vent plug (Item 1) [A] at the top of the fuel filter.

Operate the priming bulb (Item 2) [A] until fuel flows from the filter vent. Tighten the fuel filter vent plug (Item 1) [A].

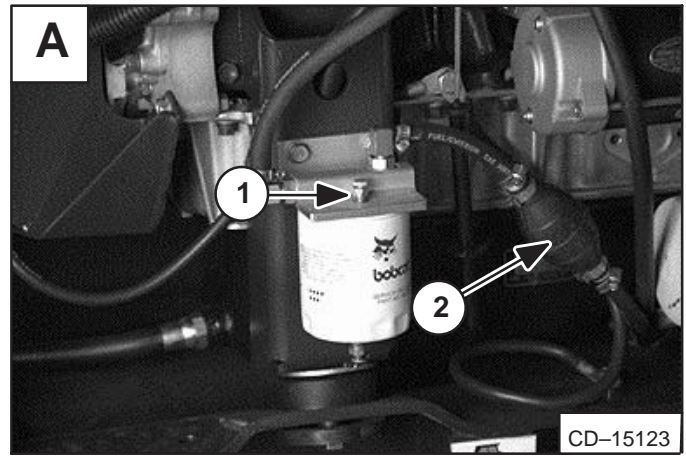

Loosen the air vent plug at the top of the fuel injection pump [B].

Again operate the priming bulb (Item 2) [A] until fuel flows from the air vent plug with no air bubbles showing.

Tighten the air vent plug at the fuel injection pump [B].

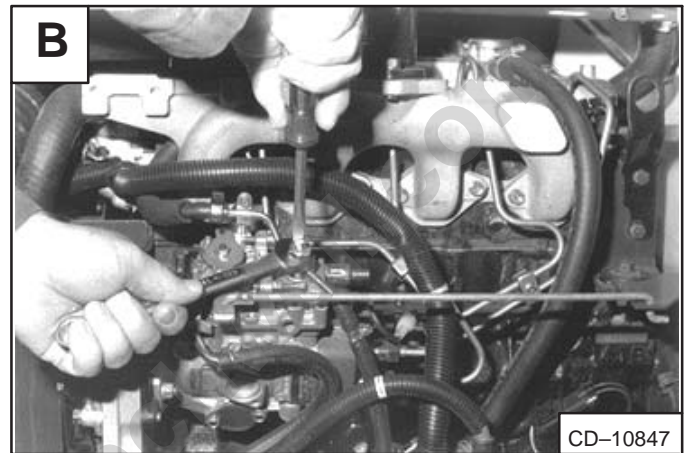

! WARNING

Always clean up spilled fuel or oil. Keep heat, flames, sparks or lighted tobacco away from fuel and oil. Failure to use care around combustibles can cause explosion or fire which can result in injury or death.

W-2103-1285

ENGINE LUBRICATION SYSTEM

Checking Engine Oil

Check the engine oil level every day.

Before starting the engine for the work shift, open the rear door. Remove the dipstick (Item 1) [A].

Keep the oil level between the marks on the dipstick.

Use a good quality motor oil that meets API Service Classification of CC, CD or CE. (See Oil Chart below.)

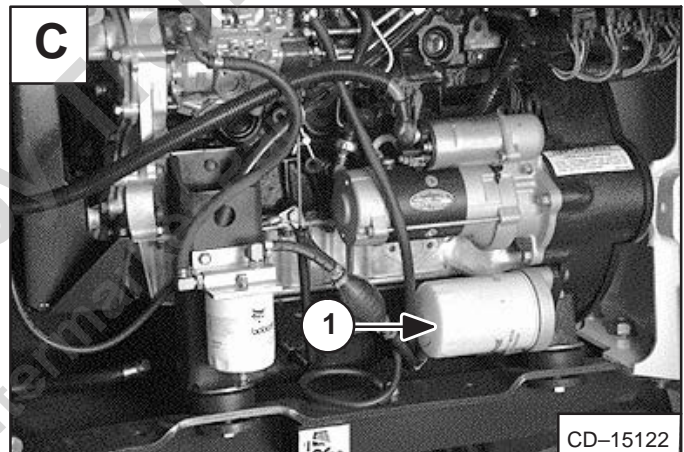
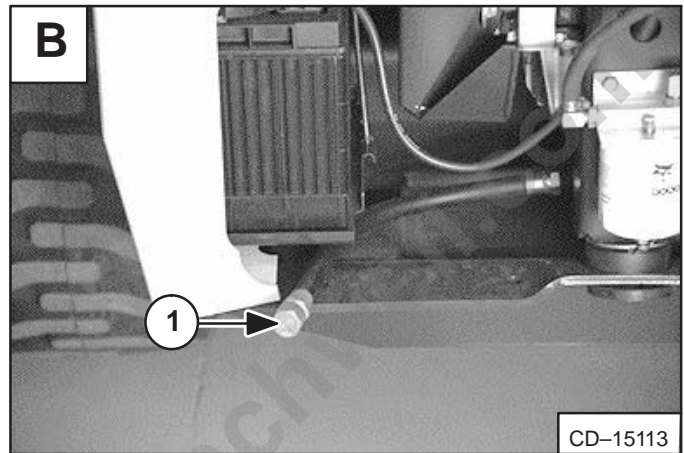
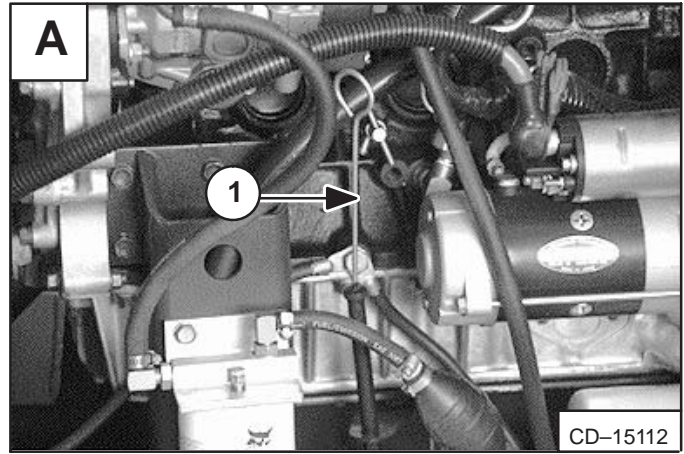
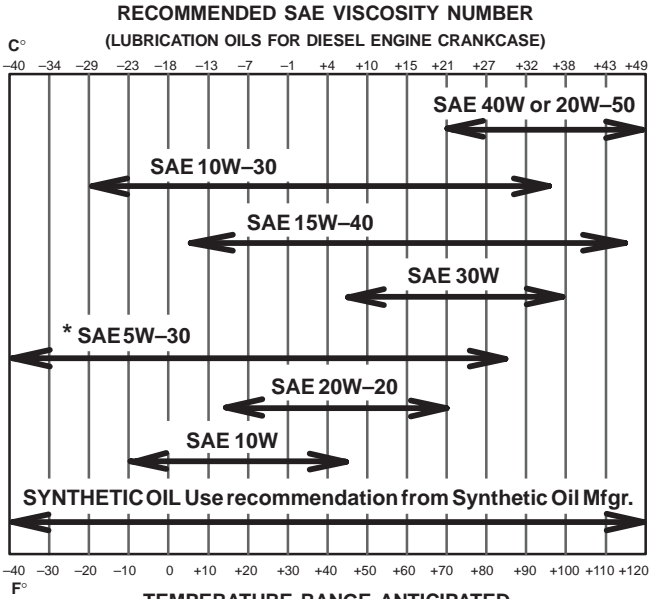

Replacing Oil And Filter

See the *SERVICE SCHEDULE*, Page 1-3 for the service interval for replacing the engine oil and filter.

Run the engine until it is at operating temperature. Stop the engine.

Open the rear door. Remove the drain plug (Item 1) [B]. Drain the oil into a container.

Remove the oil filter (Item 1) [C].

Clean the filter housing surface. Put clean oil on the new oil filter gasket. Install the filter and hand tighten only.

Install and tighten the drain plug.

ENGINE LUBRICATION SYSTEM (Cont'd)

Replacing Oil And Filter (Cont'd)

Remove the oil filler cap (Item 1) [A].

Put 8 qts. (7,6 L) of oil in the engine. (See Oil Chart, Page 1-16.)

Start the engine and let it run for several minutes. Stop the engine. Check for leaks at the oil filter. Add oil as needed if it is not at the top mark on the dipstick.

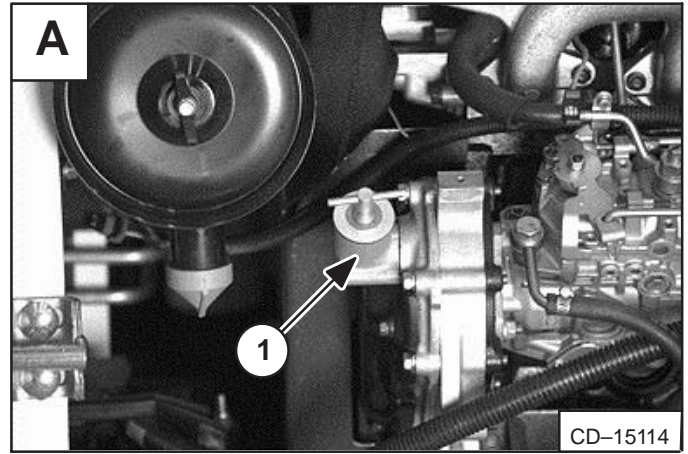

WARNING

Always clean up spilled fuel or oil. Keep heat, flames, sparks or lighted tobacco away from fuel and oil. Failure to use care around combustibles can cause explosion or fire which can result in injury or death.

W-2103-1285

Provided for Free by Trenchwell.com
Shop Aftermarket Parts

ENGINE COOLING SYSTEM

Checking The Coolant Level

Check the cooling system every day to prevent over-heating, loss of performance or engine damage.

Open the rear door. Check the coolant level in the coolant recovery tank on the right side of the engine [A].

The coolant recovery tank must be 1/3 full.

NOTE: The loader is factory filled with propylene glycol coolant. DO NOT mix propylene glycol with ethylene glycol.

Propylene Glycol

Add premixed coolant, 47% water and 53% propylene glycol to the recovery tank if the coolant level is low.

One gallon and one pint of propylene glycol mixed with one gallon of water is the correct mixture of coolant to provide a -34°F (-37°C) freeze protection.

Use a refractometer to check the condition of propylene glycol in your cooling system.

Ethylene Glycol

Add premixed coolant, 50% water and 50% ethylene glycol to the recovery tank if the coolant level is low.

Cleaning The Cooling System

Raise the rear grill.

Use air pressure or water pressure to clean the top of the oil cooler [B].

Raise the oil cooler and clean the top of the radiator [C].

Check cooling system for leaks.

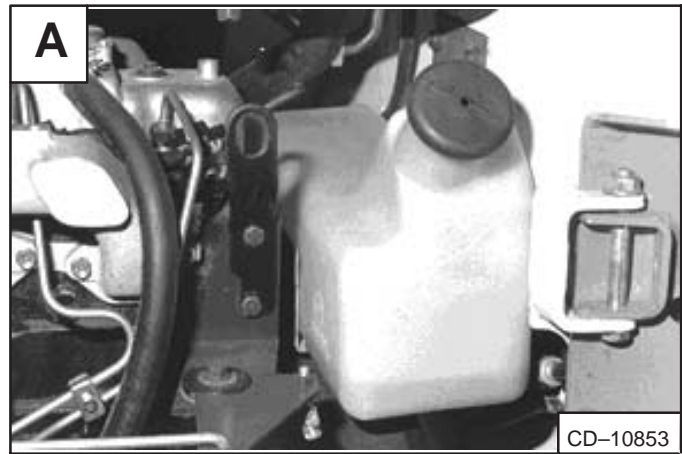

IMPORTANT

AVOID ENGINE DAMAGE

Always use the correct ratio of water to anti-freeze.

Too much antifreeze reduces cooling system efficiency and may cause serious premature engine damage.

Too little antifreeze reduces the additives which protect the internal engine components; reduces the boiling point and freeze protection of the system.

Always add a premixed solution. Adding full strength concentrated coolant can cause serious premature engine damage.

I-2124-0497

ENGINE COOLING SYSTEM (Cont'd)**Replacing The Coolant****WARNING**

Do not remove radiator cap when the engine is hot. You can be seriously burned.

W-2070-1285

Open the rear door. Open the rear grill.

Remove the radiator cap (Item 1) [A].

Remove the drain plug (Item 1) [B] from the side of the engine block. Drain the coolant into a container.

After all the coolant is removed, install and tighten the drain plug.

Propylene Glycol

Add premixed coolant; 47% water and 53% propylene glycol to the recovery tank if the coolant level is low.

One gallon and one pint of propylene glycol mixed with one gallon of water is the correct mixture of coolant to provide a -34°F (-37°C) freeze protection.

Mix the coolant in a separate container. See *SPECIFICATIONS*, Page 9-1 for correct capacity.

Fill the radiator and engine block with the premixed coolant.

Install the radiator cap.

Fill the coolant recovery tank 1/3 full.

Run the engine until it is at operating temperature. Stop the engine. Check the coolant level in the recovery tank when cool. Add coolant to the recovery tank as needed.

IMPORTANT**AVOID ENGINE DAMAGE**

Always use the correct ratio of water to anti-freeze.

Too much antifreeze reduces cooling system efficiency and may cause serious premature engine damage.

Too little antifreeze reduces the additives which protect the internal engine components; reduces the boiling point and freeze protection of the system.

Always add a premixed solution. Adding full strength concentrated coolant can cause serious premature engine damage.

I-2124-0497

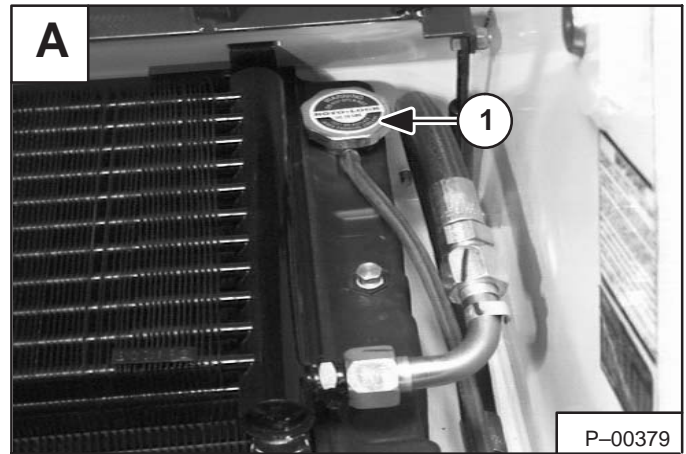

P-00379

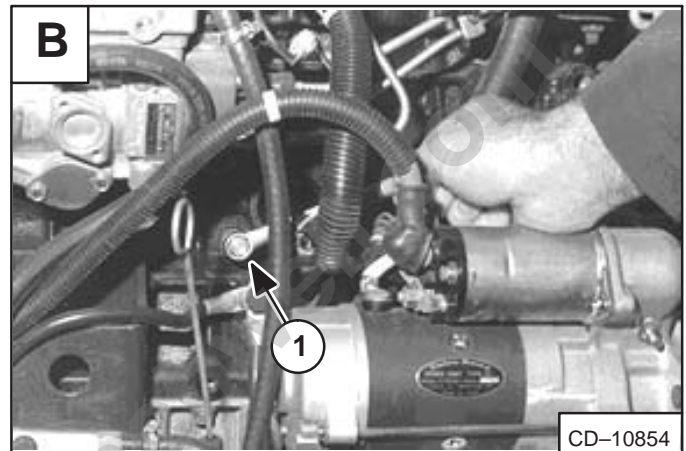

CD-10854

ALTERNATOR BELT

Adjusting The Alternator Belt

Stop the engine.

Raise the operator cab. (See Page 1–8.)

Loosen the alternator mounting bolt (Item 1) [A].

Loosen the adjustment bolt (Item 2) [A].

Move the alternator until the belt has 5/16 inch (8,0 mm) movement at the middle of the belt span with 15 lbs. (66 N) of force.

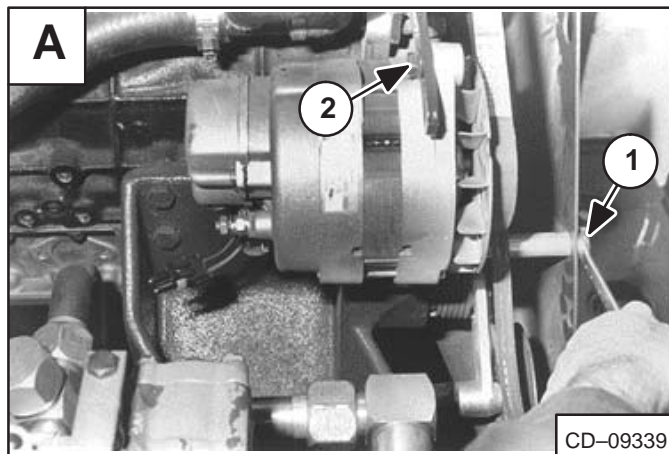

Provided for Free by Trenchwell.com
Shop Aftermarket Parts

HYDRAULIC/HYDROSTATIC SYSTEM

Checking And Adding Fluid

Use only recommended fluid in the hydraulic system. See *SPECIFICATIONS*, Page 9–1 for the correct fluid.

To check the reservoir, use the following procedure:

Put the Bobcat loader on a level surface. Lower the lift arms and tilt the Bob-Tach fully back.

Stop the engine.

Remove the dipstick **[A]**.

The fluid level must be between the marks on the dipstick.

If fluid is needed, remove the fill cap (Item 1) **[B]**.

NOTE: Before installing the fill cap, make sure the rubber gasket is installed on the fill cap (Inset **[B]**).

Add the fluid as needed to bring the level to the top mark on the dipstick **[A]**.

Replacing Hydraulic/Hydrostatic Filters

See the *SERVICE SCHEDULE*, Page 1–3 for the correct service interval.

Raise the operator cab. (See Page 1–8.)

Use a filter wrench and remove the filter elements (Item 1 & 2) **[C]**.

Clean the surface of the filter housing where the element seal contacts the housing. Put clean oil on the rubber seal of the filter element.

Install and hand tighten the filter elements.

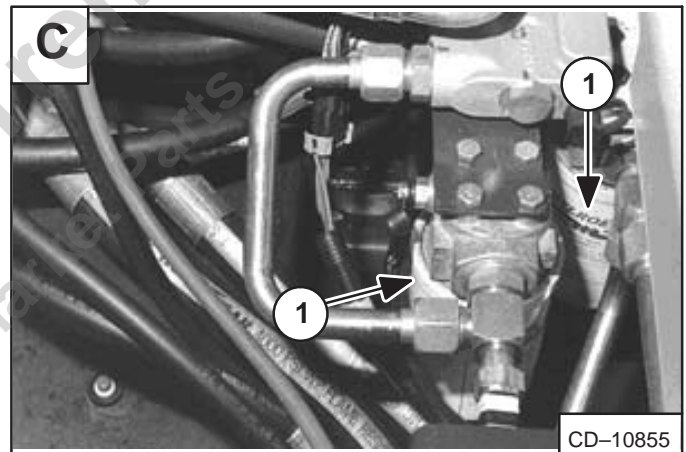
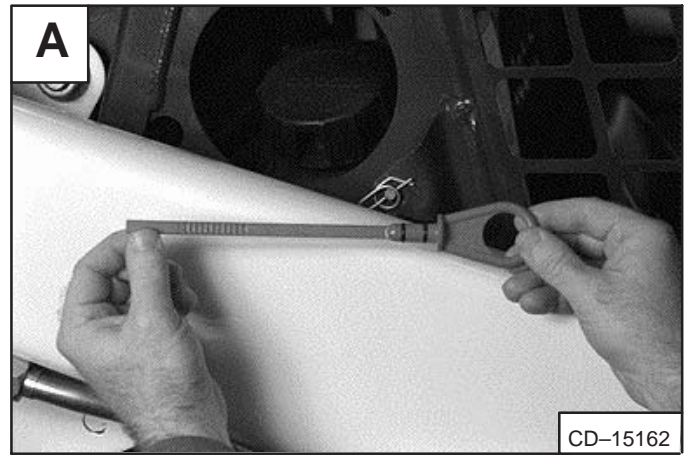

HYDRAULIC/HYDROSTATIC SYSTEM (Cont'd)**Replacing The Hydraulic Fluid**

See the *SERVICE SCHEDULE*, Page 1–3 for the service interval.

The fluid must also be replaced if it becomes contaminated or after major repairs.

Remove the reservoir fill cap (Item 1) [A].

NOTE: Before installing the fill cap, make sure the rubber gasket is installed on the fill cap (Inset) [A].

Remove the screen (Item 1) [B] and thoroughly clean with clean solvent.

Raise the operator cab. (See Page 1–8.)

NOTE: Case drain filters are added to later model loaders listed below:

S/N 510125001 & Above
S/N 510250001 & Above
S/N 510374001 & Above

Remove the two case drain filters (Item 1) [C] & [D] (one for each hydrostatic motor) and clean thoroughly or replace filters.

When all the fluid is removed from the reservoir, connect and tighten the filters and case drain hoses.

Add the correct fluid to the reservoir until the fluid level is between the marks on the dipstick. DO NOT fill above the top mark on the dipstick.

Lower the operator cab. Start the engine and operate the loader hydraulic controls.

Lower the lift arms. Stop the engine. Check for leaks. Check the fluid level in the reservoir and add as needed.

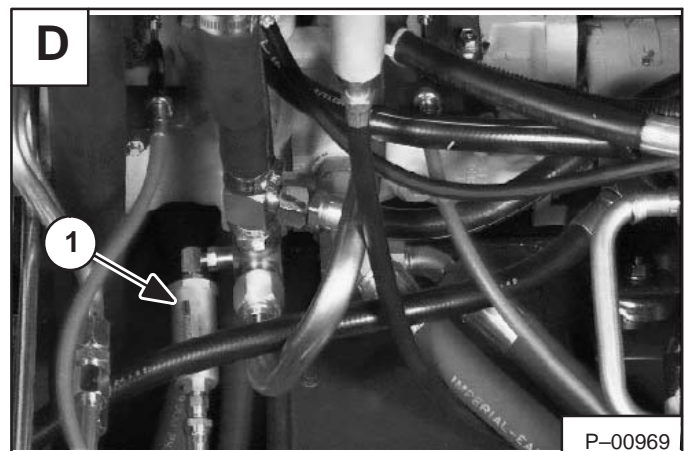
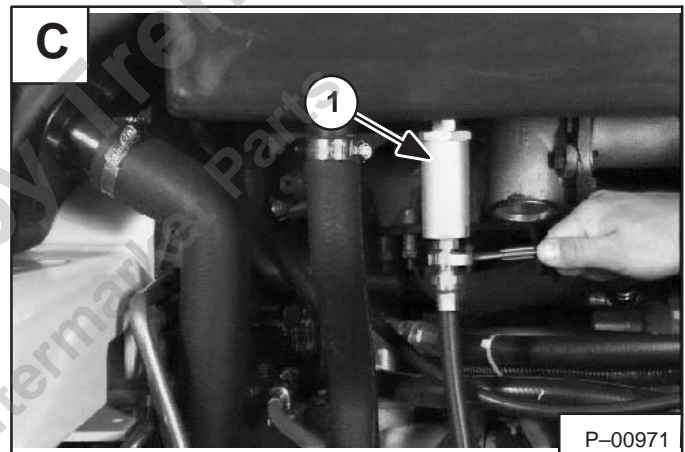
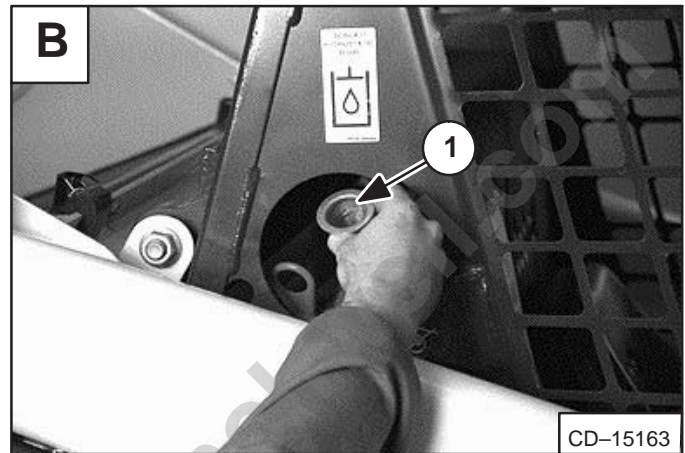
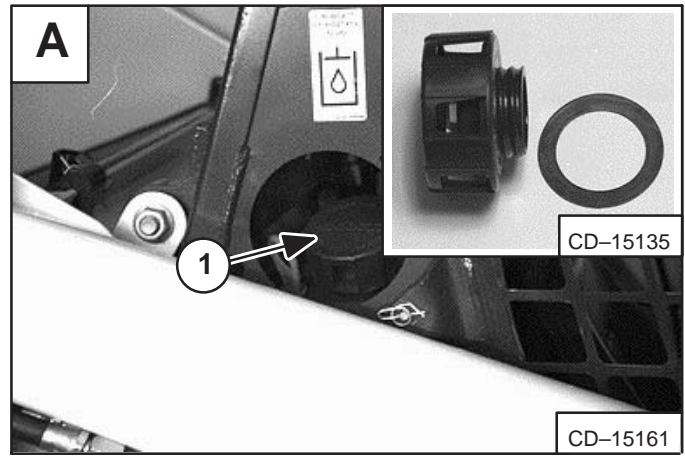
**WARNING**

Always clean up spilled fuel or oil. Keep heat, flames, sparks or lighted tobacco away from fuel and oil. Failure to use care around combustibles can cause explosion or fire which can result in injury or death.

W-2103-1285

HYDRAULIC/HYDROSTATIC SYSTEM (Cont'd)

Hydraulic Reservoir Breather Cap

See *SERVICE SCHEDULE*, Page 1–3 for the correct service interval.

Remove the breather cap [A].

NOTE: Make sure the rubber gasket is installed on the breather cap (Inset) [A].

Make sure the baffle washer is installed in the hydraulic reservoir [B].

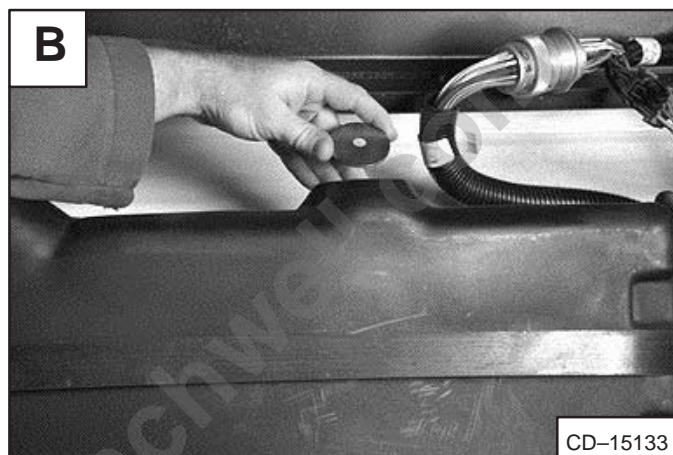
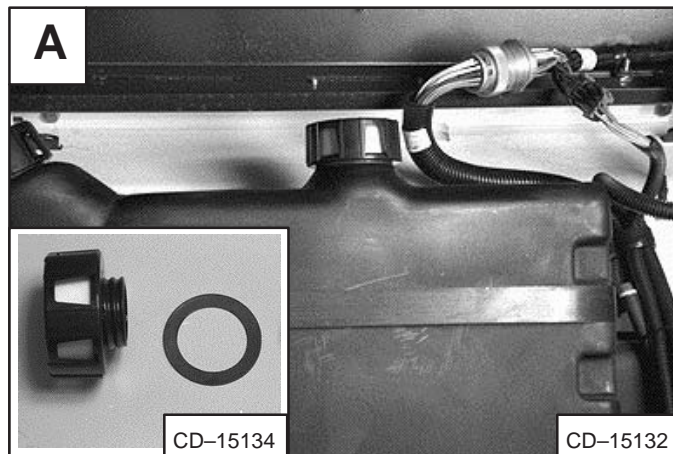

Provided for Free by Trenchworks
Shop Aftermarket Parts

SPARK ARRESTOR MUFFLER**Cleaning Procedure**

See the *SERVICE SCHEDULE*, Page 1–3 for service interval for cleaning the spark arrestor muffler.

Do not operate the loader with a defective exhaust system.

IMPORTANT

This loader is factory equipped with a U.S.D.A. Forestry Service approved spark arrestor muffler. It is necessary to do maintenance on this spark arrestor muffler to keep it in working condition. The spark arrestor muffler must be serviced by dumping the spark chamber every 100 hours of operation.

If this machine is operated on flammable forest, brush or grass covered land, it must be equipped with a spark arrestor attached to the exhaust system and maintained in working order. Failure to do so will be in violation of California State Law, Section 4442 PRC.

Make reference to local laws and regulations for spark arrestor requirements.

I-2022-0595

Stop the engine. Open the rear door and rear grill.

Remove the plug (Item 1) [A] from the bottom of the muffler.

! WARNING

When the engine is running during service, the steering levers must be in neutral and the parking brake engaged. Failure to do so can cause injury or death.

W-2006-0284

Start the engine and run for about 10 seconds while a second person, wearing safety glasses, holds a piece of wood over the outlet of the muffler.

Stop the engine. Put anti-seize coating on plug. Install and tighten the plug. Lower the rear grill and close the rear door.

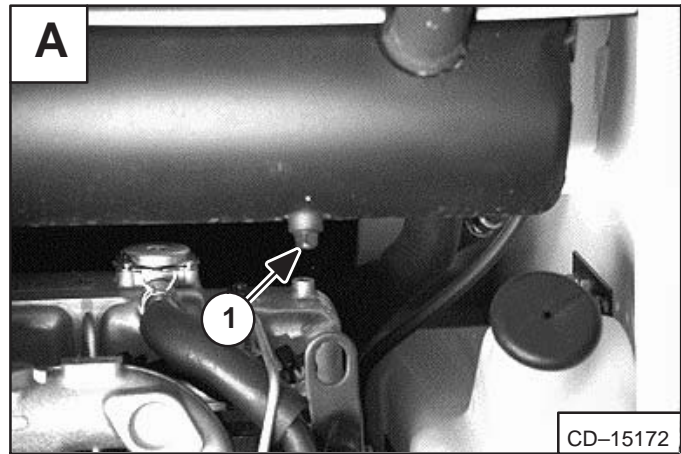

CD-15172

! WARNING

When an engine is running in an enclosed area, fresh air must be added to avoid concentration of exhaust fumes. If the engine is stationary, vent the exhaust outside. Exhaust fumes contain odorless, invisible gases which can kill without warning.

W-2050-1285

Stop engine and allow the muffler to cool before cleaning the spark chamber. Wear safety glasses or goggles. Failure to obey can cause serious injury.

W-2011-1285

Never use machine in atmosphere with explosive dust or gases or where exhaust can contact flammable material. Failure to obey warnings can cause injury or death.

W-2068-1285

TIRE MAINTENANCE

Wheel Nuts

See the *SERVICE SCHEDULE*, Page 1–3 for the service interval to check the wheel nuts. The correct torque is 105–115 ft.-lbs. (142–156 Nm) torque [A].

Tire Rotation

Check the tires regularly for wear, damage and pressure. See *SPECIFICATIONS* Page 9–1 for the correct tire pressure.

Rear tires usually wear faster than front tires. To keep tire wear even, move the front tires to the rear and rear tires to the front [B].

It is important to keep the same size tires on each side of the loader. If different sizes are used, each tire will be turning at a different rate and cause excessive wear. The tread bars of all the tires must face the same direction.

Recommended tire pressure must be maintained to avoid excessive tire wear and loss of stability and handling capability. Check for the correct pressure before operating the loader.

Tire Mounting

Tires are to be repaired only by an authorized person using the proper procedures and safety equipment. Tires and rims must always be checked for correct size before mounting. Check rim and tire bead for damage.

The rim flange must be cleaned and free of rust. The tire bead and rim flange must be lubricated with a rubber lubricant before mounting the tire, avoid excessive pressure which can rupture the tire and cause serious injury or death. During inflation of the tire, check the tire pressure frequently to avoid over inflation.

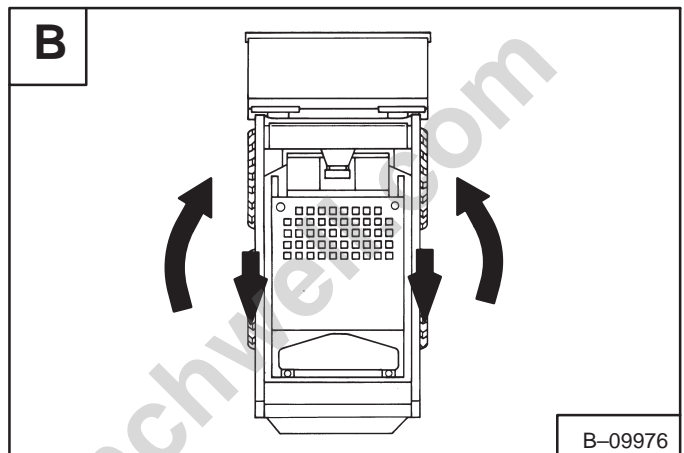
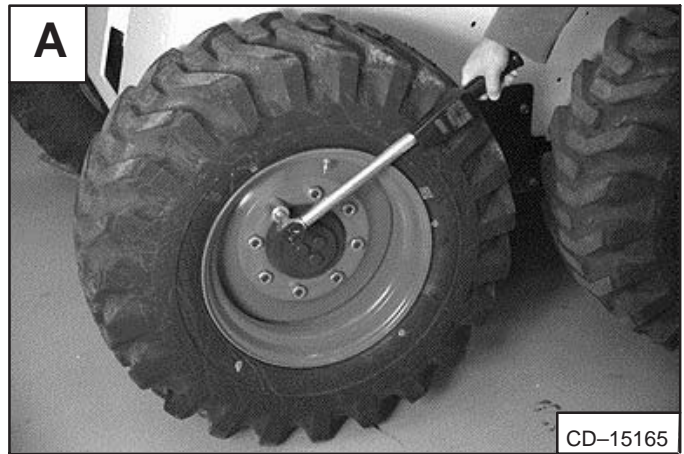

!
WARNING

Do not inflate tires above specified pressure. Failure to use correct tire mounting procedure can cause an explosion which can result in injury or death.

W-2078-1285

IMPORTANT

Inflate tires to the **MAXIMUM** pressure shown on the sidewall of the tire. **DO NOT** mix brands of tires used on the same loader.

I-2057-0794

FINAL DRIVE TRANSMISSION (CHAINCASE)

Checking And Adding Oil

The chaincase contains the final drive sprockets and chains and uses the same type of oil as the hydraulic/hydrostatic system. See *SPECIFICATIONS*, Page 9-1.

To check the chaincase oil level, use the following procedure:

Drive the loader on a level surface. Stop the engine.

Remove the plug (Item 1) **[A]** from the front of the chaincase housing.

If oil can be reached with the tip of your finger through the hole, the oil level is correct.

If the level is low, add oil through the check plug hole until the oil flows from the hole. Install and tighten the plug.

FAN GEARBOX

Checking And Maintaining

See the *SERVICE SCHEDULE*, Page 1-3 for the correct service interval.

Raise the operator cab. (See Page 1-8.)

Remove the plug (Item 1) **[B]** to check the lubricant level.

If the level is low, add SAE 90W gear lube through the check plug hole until the lubricant flows from the hole. Install and tighten the plug.

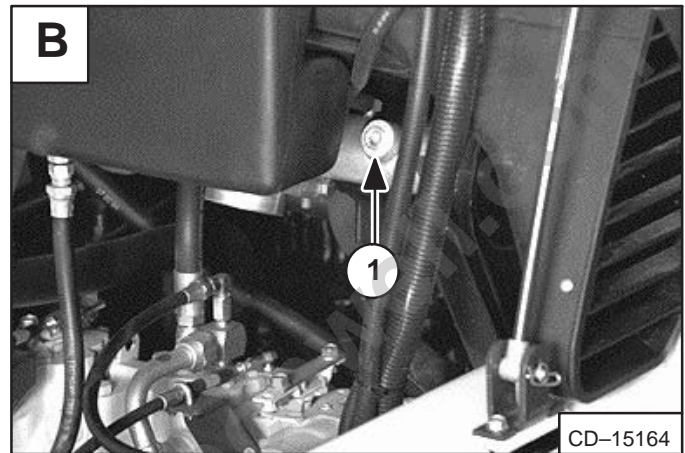
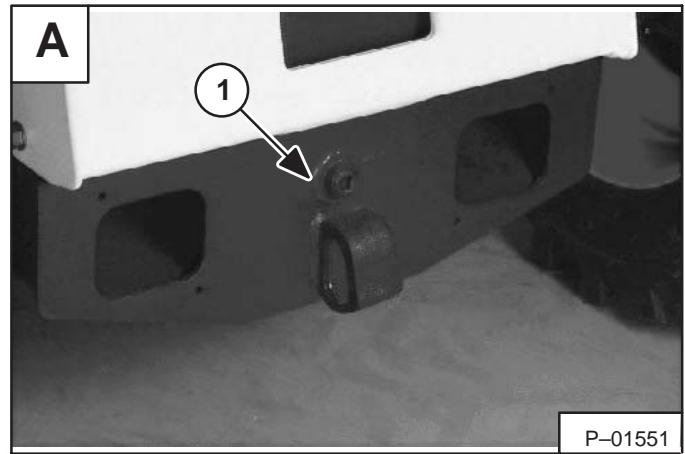

LUBRICATING THE LOADER

Procedure

Lubricate the loader as specified in the *SERVICE SCHEDULE*, Page 1–3 for the best performance of the loader.

Record the operating hours each time you lubricate the Bobcat loader.

Always use a good quality lithium based multi-purpose grease when you lubricate the loader. Apply the lubricant until extra grease shows.

Lubricate the following locations on the loader:

1. Rod End Lift Cylinder (Both Sides) [A].
2. Base End Lift Cylinder (Both Sides) [B].

3. Lift Arm Pivot Pin (Both Sides) [C].

4. Base End Tilt Cylinder [D].

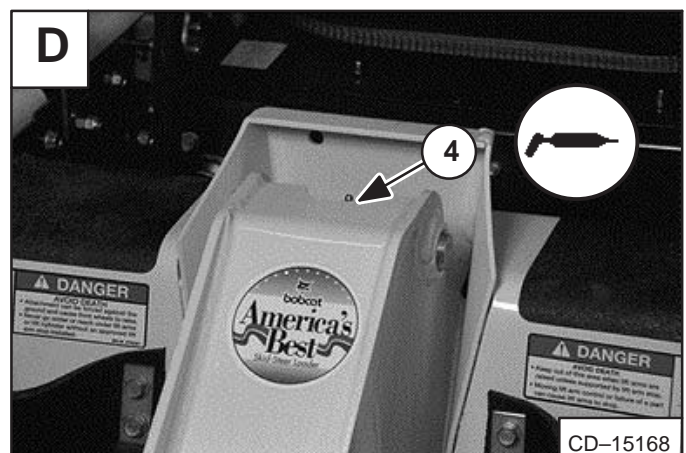
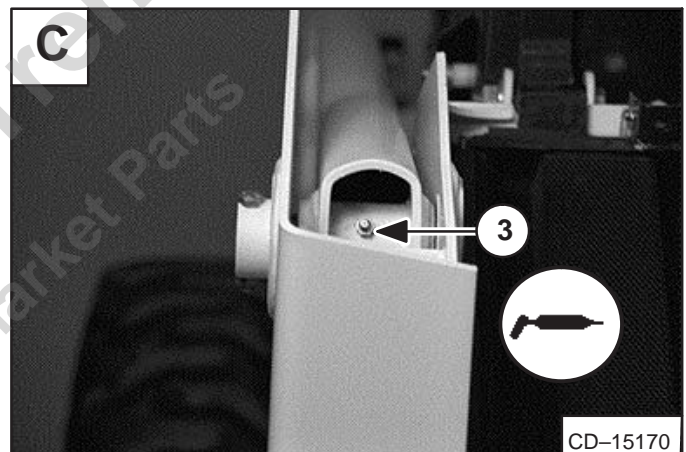
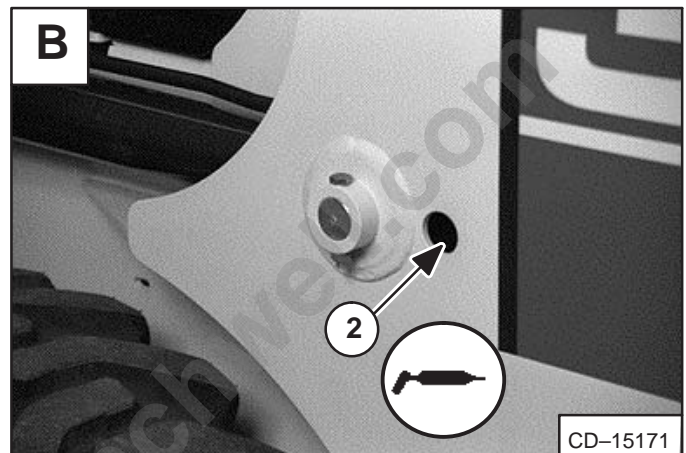
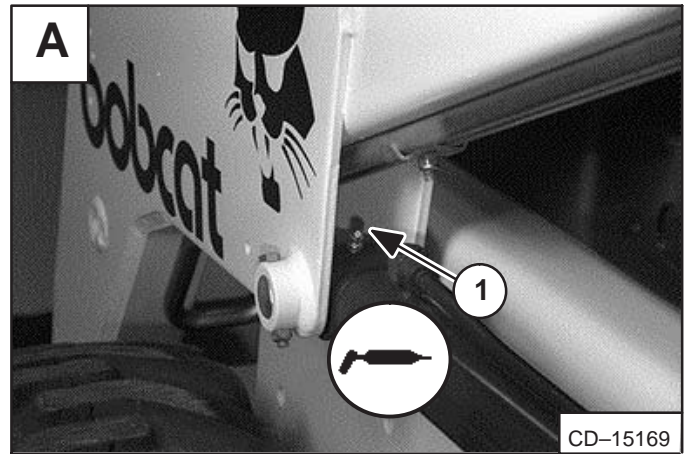

LUBRICATING THE LOADER (Cont'd)

Procedure (Cont'd)

5. Rod End Tilt Cylinder [A].

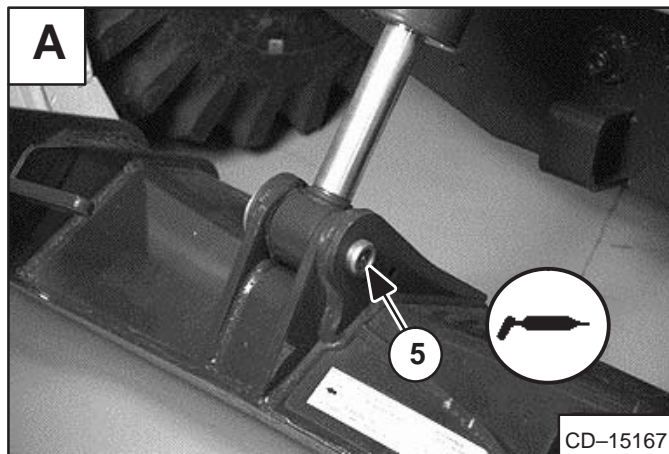

6. Bob-Tach Pivot Pin (Both Sides) [B].

7. Bob-Tach Wedge (Both Sides) [B].

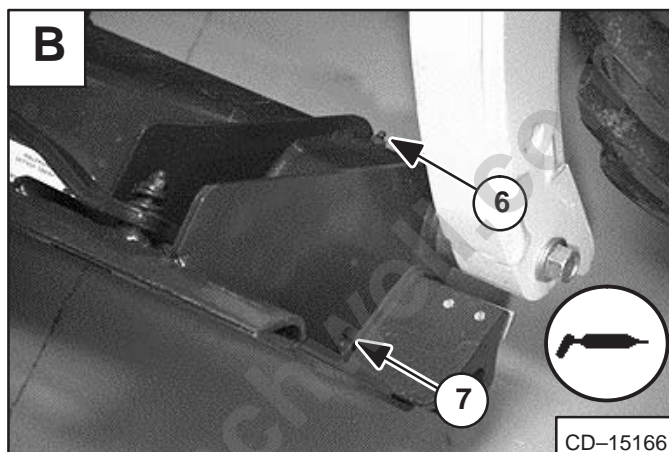

8. **250 Hours:** Steering Lever Shaft and Centering Mechanism [C].

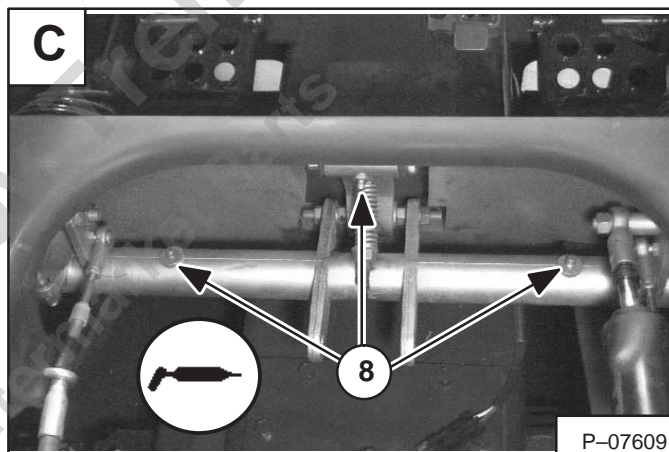

REMOTE START SWITCH

Procedure

The tool listed will be needed to do the following procedure:

MEL1398 – Remote Start Switch
MEL1416 – Adapter Harness (853 Base Only)

The remote start switch is required when the service technician is adjusting the steering linkage, checking the hydraulic/hydrostatic system.

Lift and block the loader. (See Page 1–4.)

Raise the operator cab. (See Page 1–8.)

Disconnect the operator cab wire harness from the engine wire harness.

Connect the remote start switch to the engine harness connectors (Item 1) [A].

853 Base Only: Use MEL1416 adapter harness (Item 1) [B]. Connect the adapter harness to the remote start switch.

Disconnect the operator cab wire harness from the engine wire harness.

Connect the adapter harness (Item 1) [C] to the engine harness connectors.

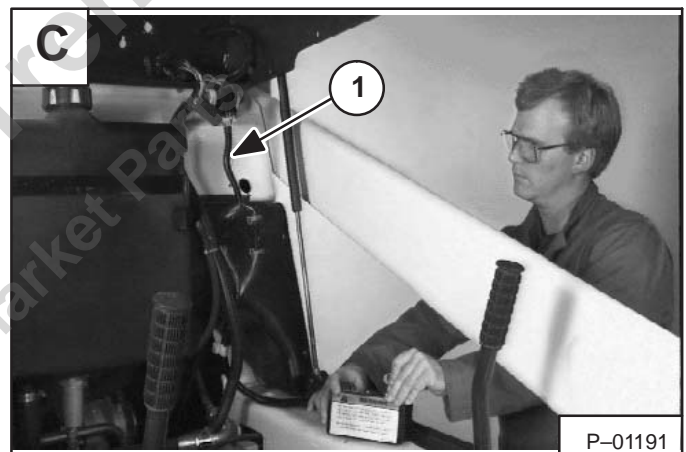
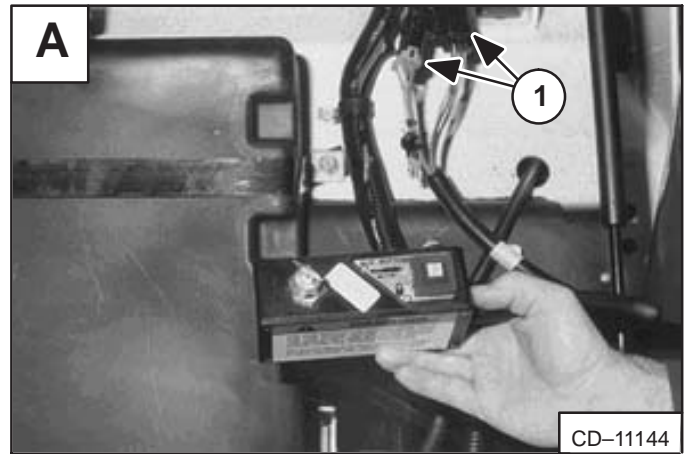



Provided for Free by www.youfixthis.com
Shop Aftermarket Parts at www.frenchwell.com

HYDRAULIC SYSTEM

	Page Number
BUCKET POSITION VALVE (S/N 5102) & (S/N 5103) Removal And Installation	2-40
CONTROL PEDALS	
Pedal Adjustment	2-42
Removal And Installation	2-42
DUAL PRESSURE MAIN RELIEF VALVE (S/N 512811001 & Above)	
W/Select Valve(JEM)	
Adjusting The Low Setting	2-26
Adjusting The High Setting	2-27
Checking The Low Setting	2-23
Checking The High Setting	2-24
FRONT AUXILIARY CONTROL VALVE (Apitech)	
Removal And Installation	2-41
HYDRAULIC CONTROL VALVE	
Removal And Installation	2-28
HYDRAULIC CYLINDER	
Assembly	2-17
Disassembly	2-15
Lift Cylinder Identification	2-13
Tilt Cylinder Identification	2-14
HYDRAULIC FLUID RESERVOIR	
Removal And Installation	2-38
HYDRAULIC PUMP	
Checking The Output Of The Pump	2-36
Removal And Installation	2-37
HYDRAULIC SYSTEM INFORMATION	
Tighten Procedure	2-7
HYDRAULIC FILTER HOUSING	
Removal And Installation	2-35
LIFT CYLINDER(S)	
Checking The Lift Cylinder	2-9
Removal And Installation	2-9
LOCK VALVE (S/N 5103)	
Removal And Installation	2-39
MAIN RELIEF VALVE	
Checking The Main Relief Valve	2-20
Checking The Main Relief Valve Without Auxiliaries	2-21
Removal And Installation	2-22
PEDAL INTERLOCK LINKAGE	
Pedal Interlock Linkage Adjustment	2-44
Removal And Installation	2-43

**HYDRAULIC
SYSTEM**



















HYDRAULIC SYSTEM (Cont'd)

	Page Number
SELECT VALVE (JEM) (S/N 512811001 & Above)	
Checking The Relief Valve	2-30
Disassembly And Assembly	2-33
Removal And Installation	2-32
Solenoid Testing	2-34
TILT CYLINDER	
Checking The Tilt Cylinder	2-11
Removal And Installation	2-11
Rod End Seal	2-12
TROUBLESHOOTING	
Chart	2-7

Provided for Free by Trenchwell.com
Shop Aftermarket Parts

HYDRAULIC SYSTEM INFORMATION

GLOSSARY OF HYDRAULIC/HYDROSTATIC SYMBOLS FOR LOADERS

SYMBOL	DESCRIPTION	SYMBOL	DESCRIPTION
FLOW LINES and CONNECTIONS		BASIC and MISCELLANEOUS SYMBOLS	
	WORKING CIRCUITS - Continuous. Solid Line - Working (Main) Line. Return Line (line conducting fluid from working devices to the reservoir) and Feed Line (main line conductor)		RESTRICTION - Line with Fixed Restriction - Affected by Viscosity (property of resistance to flowing fluid)
	PILOT PRESSURE - Dashed Line - Pilot Line (line which conducts control fluid)		VARIABLE ADJUSTMENT RESTRICTION - Regulated or Variable Restriction
	DRAIN CIRCUITS - Dotted Line - Drain Line (drain or bleed line - line conducting fluid from a component housing to the reservoir)		TEMPERATURE CONTROL - (indication of temperature)
	COMPONENTS - Long Chain Line - Enclosure outline for several components assembled in one unit		TEMPERATURE INDICATOR - (temperature measurement - thermometer)
	MECHANICAL CONNECTIONS - Double Line (Shaft, Lever, Piston Rod)		FILTER (strainer or screen) - For fluid conditioning
	CONNECTED JUNCTION OF OIL LINES (Flow Line Connection)		VENTED AND FILTERED RESERVOIR (reservoir open to atmosphere)
	OIL LINES CROSSING (NOT Connected)		OIL COOLER (heat exchanger) - The arrows in the diamond indicate the extraction of heat (heat dissipation)
	COUPLER - Quick-Acting Coupling (uncoupled, closed by non-return valve)		PRESSURE SENSOR - Varies electric signal with pressure
			DIFFERENTIAL PRESSURE SWITCH - Switch activates when pressure difference reaches specified level
			PRESSURE SWITCH - Switch activates when pressure reaches specified level
			MUFFLER (silencer) - Reduces noise

HYDRAULIC SYSTEM INFORMATION (Cont'd)

GLOSSARY OF HYDRAULIC/HYDROSTATIC SYMBOLS FOR LOADERS

SYMBOL DESCRIPTION

SYMBOL DESCRIPTION

CYLINDER: Equipment to convert hydraulic energy into linear energy and in which the fluid pressure operates alternately in both directions (forward and backward strokes)

CONTROL MECHANISMS



DOUBLE ACTING HYDRAULIC CYLINDER, UNEQUAL DISPLACEMENT - With single piston rod



CONTROL VALVE WITH DETENT (Holds Valve in Position) - device for maintaining a given position (mechanical)



DOUBLE ACTING HYDRAULIC CYLINDER, UNEQUAL DISPLACEMENT and CUSHION ON ONE END - With single piston rod



CONTROL VALVE ACTIVATED BY A PULL BUTTON (manual)



CONTROL VALVE ACTIVATED BY A PUSH-PULL BUTTON (manual)

PUMP: To convert mechanical energy into hydraulic energy



CONTROL VALVE ACTIVATED BY A LEVER (manual)



FIXED CAPACITY DISPLACEMENT HYDRAULIC PUMP - With one direction of flow



CONTROL VALVE ACTIVATED BY A PEDAL (manual)



VARIABLE CAPACITY DISPLACEMENT BIDIRECTIONAL HYDRAULIC PUMP - With two directions of flow (bidirectional)



CONTROL VALVE WITH SPRING RETURN (mechanical)

MOTOR: To convert hydraulic energy into rotary mechanical energy



CONTROL VALVE ACTIVATED BY AN ELECTRIC SOLENOID (electrical)



FIXED CAPACITY DISPLACEMENT BIDIRECTIONAL HYDRAULIC MOTOR - With two directions of flow (bidirectional)



CONTROL VALVE ACTIVATED BY PILOT PRESSURE (indirect control, pilot actuated by application of pressure)

HYDRAULIC SYSTEM INFORMATION (Cont'd)

GLOSSARY OF HYDRAULIC/HYDROSTATIC SYMBOLS FOR LOADERS

SYMBOL DESCRIPTION

SYMBOL DESCRIPTION

NON-RETURN VALVE, SHUTTLE VALVE: Valve which allows free flow in one direction only

PRESSURE CONTROL VALVE: Valve ensuring the control of pressure



NON-RETURN VALVE (Check Valve) - Used as Replenishing Valve, Load Check Valve or Anticavitation Valve - Opens if the Inlet pressure is higher than the Outlet pressure. Often contains internal spring which has NO significant pressure value

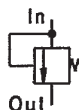

RELIEF VALVE - When the Inlet pressure overcomes the opposing force of the spring, the valve opens permitting flow from the Outlet port.

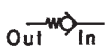

SPRING LOADED VALVE (Bypass Valve) - Opens if the Inlet pressure is greater than the Outlet pressure plus the spring pressure

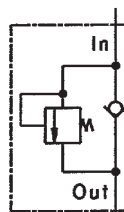

RELIEF/REPLENISHING VALVE or RELIEF/ANTICAVITATION VALVE - When the Inlet pressure overcomes the opposing force of the spring, the valve opens permitting flow from the Outlet port - Allows free flow in the opposite direction

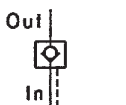

PILOT CONTROLLED NON-RETURN VALVE - It is possible to open the valve by pilot pressure

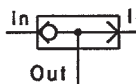

SHUTTLE VALVE - The Inlet port connected to the higher pressure is automatically connected to the Outlet port while the other Inlet port is closed



DUAL PRESSURE RELIEF VALVE - When the inlet pressure overcomes the opposing force of the spring, the valve opens permitting flow from the Outlet port. Pilot pressure provides a second pressure value.

DIRECTIONAL CONTROL VALVE: Valve providing for the opening (fully or restricted) or the closing of one or more flow paths (represented by several squares)

FLOW CONTROL VALVE: Valve controlling the flow in one or both directions



TWO PORTS and CLOSED FLOW PATHS

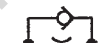

ONE WAY RESTRICTOR VALVE (Non-Return Valve with Restriction) - Unit allowing free flow in one direction but restricted flow in the other direction



SOLENOID ACTIVATED DIRECTIONAL CONTROL VALVE (Two Position) - controlled by an electric solenoid (with return spring)



TOW VALVE - Normally in closed position



PILOT ACTIVATED DIRECTIONAL CONTROL VALVE (Two Position) - controlled by pressure (with return spring)



bobcat[®]

Provided for Free by Trenchwell.com
Shop Aftermarket Parts



HYDRAULIC / HYDROSTATIC SYSTEM OPERATIONS

To Be Used With

HYDRAULIC / HYDROSTATIC FLOW CHART

For Model

853H

Chart #6720956 (Printed March 2003)

CHART LEGEND

- | | |
|---|---|
| ① RESERVOIR, Cap.: . . . 15.5 Qts. (14,7 L) | ③① LOAD CHECK VALVE (2) |
| ② BREATHER, 5 Micron | ③② RESTRICTOR |
| ③ FILL CAP | ③③ RELIEF VALVE (HIGH FLOW)
3250-3350 PSI (22409-23098 kPa) |
| ④ SCREEN, 60 Mesh | ③④ PORT RELIEF, . . . 3500 PSI (24132 kPa) |
| ⑤ REAR AUXILIARY QUICK COUPLERS
(OPTIONAL) | ③⑤ ELECTRICAL SOLENOID VALVE |
| ⑥ CHECK VALVE, 225-290 PSI
(1551-2000 kPa) | ③⑥ MAIN RELIEF VALVE, . . . 2550-2600 PSI
(17582-17927 kPa) |
| ⑦ HYDROSTATIC MOTOR | ③⑦ HYDRAULIC FILTER, #4 Media |
| ⑧ PORT RELIEF VALVE (OPTIONAL)
2550-2600 PSI (17582-17927 kPa) | ③⑧ CHECK VALVE, 1 PSI (7 kPa) |
| ⑨ FRONT AUXILIARY VALVE | ③⑨ DIFFERENTIAL PRESSURE SWITCH
(Normally Closed) 36-44 PSI
(248-303 kPa) |
| ⑩ OPEN CHECK PILOT VALVE (OPTIONAL)
30 PSI (207 kPa) | ③⑩ BY-PASS VALVE, 44-55 PSI
(310-379 kPa) |
| ⑪ ELECTRICAL VALVE SOLENOIDS | ④① CHARGE FILTER, #4Media |
| ⑫ RELIEF VALVE (HIGH FLOW)
3250-3350 PSI (22409-23098 kPa)
@ 18 GPM (68,1 L/min.) | ④② FLUID TEMPERATURE SENSOR |
| ⑬ ELECTRICAL SELECTIVE VALVE | ④③ LOCK VALVE (OPTIONAL) |
| ⑭ CHECK VALVE | ④④ PORT BLOCK |
| ⑮ CASE DRAIN COUPLER | ④⑤ COLD OIL BY-PASS VALVE, . . . 85 PSI
(586 kPa) |
| ⑯ FRONT AUXILIARY QUICK COUPLERS | ④⑥ HYDROSTATIC PUMP |
| ⑰ HIGH FLOW QUICK COUPLERS | ④⑦ DISPLACEMENT CONTROL VALVE |
| ⑱ SIDE SHIFT QUICK COUPLERS | ④⑧ CHARGE PRESSURE SENSOR |
| ⑲ TILT CYLINDER | ④⑨ CHARGE RELIEF VALVE
100° F. (38° C.) Fluid @ Full RPM
Neutral 310-330 PSI (2137-2275 kPa)
Stroked 300-320 PSI (2069-2206 kPa) |
| ⑳ LIFT CYLINDER | ⑤① HIGH PRESSURE RELIEF/REPLENISHING
VALVE, 5000 PSI (34475 kPa) |
| ㉑ BUCKET POSITION VALVE | ⑤② CHARGE PUMP, 11.0 GPM (41,6 L/min.) |
| ㉒ FLOW ADJUSTMENT VALVE | ⑤③ TOW VALVES |
| ㉓ FLOW CONTROL SPOOL | ⑤④ HYDRAULIC PUMP, . . . @ 2750 RPM
@ 1150 PSI (7929 kPa)
a. 18.0 GPM (68,1 L/min.)
b. 6.0 GPM (22,7 L/min.) |
| ㉔ CHECK VALVE | ⑤⑤ OIL COOLER |
| ㉕ UN-LOADING SPOOL/PRESS. RELIEF
VALVE | |
| ㉖ CONTROL VALVE POWER-BEYOND
OUTLET | |
| ㉗ AUXILIARY ELECTRICAL SOLENOIDS | |
| ㉘ ANTI-CAVITATION VALVE | |
| ㉙ HYDRAULIC CONTROL VALVE | |

FLUID FLOW EXPLANATION

The fluid flows by gravity from the reservoir ① to the "tee" fitting on the front of the hydrostatic pump ④⑤ . The tee fitting at the hydrostatic pump ④⑤ routes the fluid to the charge pump ⑤⑩ and to the hydraulic pump ⑤② , also return fluid comes from the right hydrostatic motor ⑦ , hydraulic filter ③⑥ and case drain coupler ⑬ .

The hydraulic pump ⑤② is a 2-stage "gear type" pump and is driven by a shaft through the hydrostatic pump ④⑤ . The fluid from the hydraulic pump ⑤② goes to the main relief valve ③⑤ and to the control valve ②⑨ . When all the spools of the control valve ②⑨ are in neutral position, the fluid goes through the control valve power beyond port ②⑥ to the front auxiliary valve ⑨ .

When the lift arms are being raised, the hydraulic pump ⑤② fluid flow is directed to the base end of the lift cylinders ②⑩ . The fluid from the rod end of the lift cylinders ②⑩ returns to the bucket position valve ②① and is directed to the center of the flow-control spool ②③ . The flow-control spool ②③ and flow adjustment valve ②② directs this flow. A percentage of the fluid is directed over the flow adjustment valve ②② to position the bucket. The rest of the fluid is directed through the orifice in the flow-control spool ②③ and on to the return port of the control valve ②⑨ (lift section).

The fluid from the flow-control spool ②③ and flow adjustment valve ②② are against the un-loading spool/pressure relief valve ②⑤ . The un-loading spool/pressure relief valve ②⑤ moves to allow extension of the tilt cylinder ①⑨ as the lift cylinders ②⑩ raise the lift arms. The un-loading spool/pressure relief valve ②⑤ is to relieve fluid from the base end of the tilt cylinder ①⑨ if the bucket is fully rolled out and the lift cylinders ②⑩ are still extending.

When the cylinders ①⑨ ②⑩ reach the end of the stroke, the fluid attains the setting of the main relief valve ③⑤ , which will open and let the fluid by-pass the circuit and go to the hydraulic filter ③⑥ which is joined by return fluid from the front auxiliary valve ⑨ when in use. When the spool goes back to neutral position, there is fluid available for the other sections of the control valve ②⑨ .

The return fluid goes through the hydraulic filter ③⑥ and joins the reservoir ① fluid at the tee fitting. The hydraulic filter ③⑥ has a by-pass valve ③⑨ to allow fluid flow when the fluid will not go through the filter element (plugged). The differential pressure switch ③⑧ is connected (electrically) to the operating system unit. The check valve ③⑦ is there to prevent the reservoir ① from draining when servicing the hydraulic filter ③⑥ .

The charge pump ⑤⑩ fluid is called "charge supply fluid". Charge fluid flows from the charge pump ⑤⑩ to the port block ④③ where it is against the cold oil by-pass valve ④④ . The cold oil by-pass valve ④④ will open when the fluid is cold and is too thick for fluid flow to go through the oil cooler ⑤③ . The charge fluid flows through the oil cooler ⑤③ and to the port block ④③ .

The charge fluid is routed from the port block ④③ to the front auxiliary control valve ⑨ and to the control valve ②⑨ . When the electrical solenoids ①① are energized, the charge pressure will shift the spool in the the front auxiliary control valve ⑨ allowing hydraulic pressure fluid to flow to either the male or female quick couplers ①⑥ . Return fluid from the quick couplers ①⑥ and control valve ②⑨ fluid returns to the hydraulic filter ③⑥ . Also when

the electrical solenoids 17 are energized, the charge pressure will shift the spool in the control valve 20 allowing pressure fluid to flow through the lock valve 42 and to the side shift quick couplers 18 or the optional rear auxiliary quick couplers 5. Return fluid from the side shift quick couplers 18 or rear auxiliary quick couplers 5 flows to the hydraulic filter 36.

NOTE: If equipped with the rear auxiliary hydraulics (Example: Rear Stabilizers), the rear auxiliary quick couplers 5 must be disconnected to make the side shift quick couplers 18 function (Example: Planer) or the side shift quick couplers 18 disconnected to make the rear auxiliary quick couplers 5 function.

Charge fluid flows through the port block 43 to the charge filter 40. The charge filter 40 has a by-pass valve 39 to allow fluid flow when the fluid will not go through the filter element (plugged). The differential pressure switch 38, fluid temperature sensor 41 and charge pressure sensor 38 are connected (electrically) to the operating system unit.

The fluid flows through the charge filter 40 to the charge relief valve 48 on the hydrostatic pumps 45. The charge fluid goes to the displacement control valve 46 and also supplies fluid for cooling and lubrication of the hydrostatic pumps 45 and motors 7.

The displacement control valves 46 angle the swash plates with charge pressure for forward and reverse travel. When the swash plates in the hydrostatic pumps 45 are angled, in either direction, the pumps 45 force fluid (drive pressure) to the hydrostatic motors 7. The motors 7 turn and push the low pressure fluid back to the pumps 45 to be used again.

The hydrostatic pumps 45 contain four high pressure relief/replenishing valves 49. The high pressure relief/replenishing valves 49 have a dual function. In neutral the valve cartridges 49 are pushed off their seats to allow fluid flow from the charge loop to cool, lubricate and replenish the pumps 45 and motors 7. In forward travel the fluid has a higher pressure than charge fluid. This pressure forces the high pressure relief/replenishing valves 49 to close to make the "drive pressure loop". The high pressure relief valves 49 will open allowing drive pressure to relieve into the charge loop to protect the system. The case drain from the hydrostatic pumps 45 goes internally to the hydraulic pump 52.

The hydrostatic motors 7 are a "roller-geroler" type. The case drain fluid from the right motor 7 goes to the tee fitting on the pump 45. Case drain fluid from the left motor 7 flows to the reservoir 1. The check valves 6 keep back pressure on the charge fluid for correct steering operation.

There are tow valves 51 located in the hydrostatic pumps 45. The tow valves 51 can be opened to move the loader a short distance, if the loader cannot move under its own power.

HIGH FLOW OPERATION

To use the high flow operation; first, engage the high flow switch which will energize the electrical solenoid 31. Then engage the front auxiliary controls which will energize the solenoids 11 and selective valve 13 and the following functions happen:

With the electrical solenoid 31 energized the relief valve 31, in the control valve 20, will

protect the hydraulic pump 52^a from high pressure. When the relief valve 32 is not open the fluid flow goes out the power-beyond port 16 to the front auxiliary valve 11. The hydraulic pump 52^b is protected from high pressure by the relief valve 12. With the selective valve 13 energized the fluid joins the fluid from the front auxiliary valve 9 and goes to the high flow quick couplers 17. Return fluid goes back to the front auxiliary valve 9 and to the hydraulic filter 36.

853H HYDRAULIC PRESSURE CHECK

NOTE: All flow and pressure checks to be made with the engine running at 2750-2850 RPM.

1. Lift and block the loader.
2. To check the hydraulic pump 52^a and main relief valve 35, connect the hydraulic tester to the quick couplers 16 or 17.
3. Engage the front auxiliary electrical switch.
4. The free flow should be 18.0 GPM (68,1 L/min.). When the free flow is restricted, the flow will drop to "0" GPM and the main relief valve 35 pressure should be 2550-2600 PSI (17582-17927 kPa). If not, adjust the main relief valve 35. If the relief valve can not be adjusted, do a direct check on the hydraulic pump 52^a.
5. While the hydraulic tester is connected to the quick couplers 16 or 17, check the high flow relief valve 32 as follows:
 - a. Disconnect the electric solenoid 13.
 - b. Engage the high flow electrical switch.
 - c. Repeat Step 3 & 4, but relief valve pressure should be 3250-3350 PSI (22409-23098 kPa). If not, adjust the relief valve 32.
6. To check the hydraulic pump 52^b and high flow relief valve 12, connect the hydraulic tester as follows:
 - a. Connect the hydraulic tester inlet to the small female coupler 16 and the outlet to the case drain quick coupler 15.
 - b. Disconnect the two electrical solenoids 11.
 - c. Reconnect the electric solenoid 13.
7. Engage the high flow electrical switch.
8. The free flow should be 6.0 GPM (22,7 L/min.). When the free flow is restricted, the flow will drop to "0" GPM and the high flow main relief 12 should be 3250-3350 PSI (22409-23098 kPa). If not, adjust the relief valve 12. If the relief valve can not be adjusted, do a direct check on the hydraulic pump 52^b.



HYDRAULIC / HYDROSTATIC FLOW CHART

For Model

853H

Chart #6720956 (Printed March 2003)

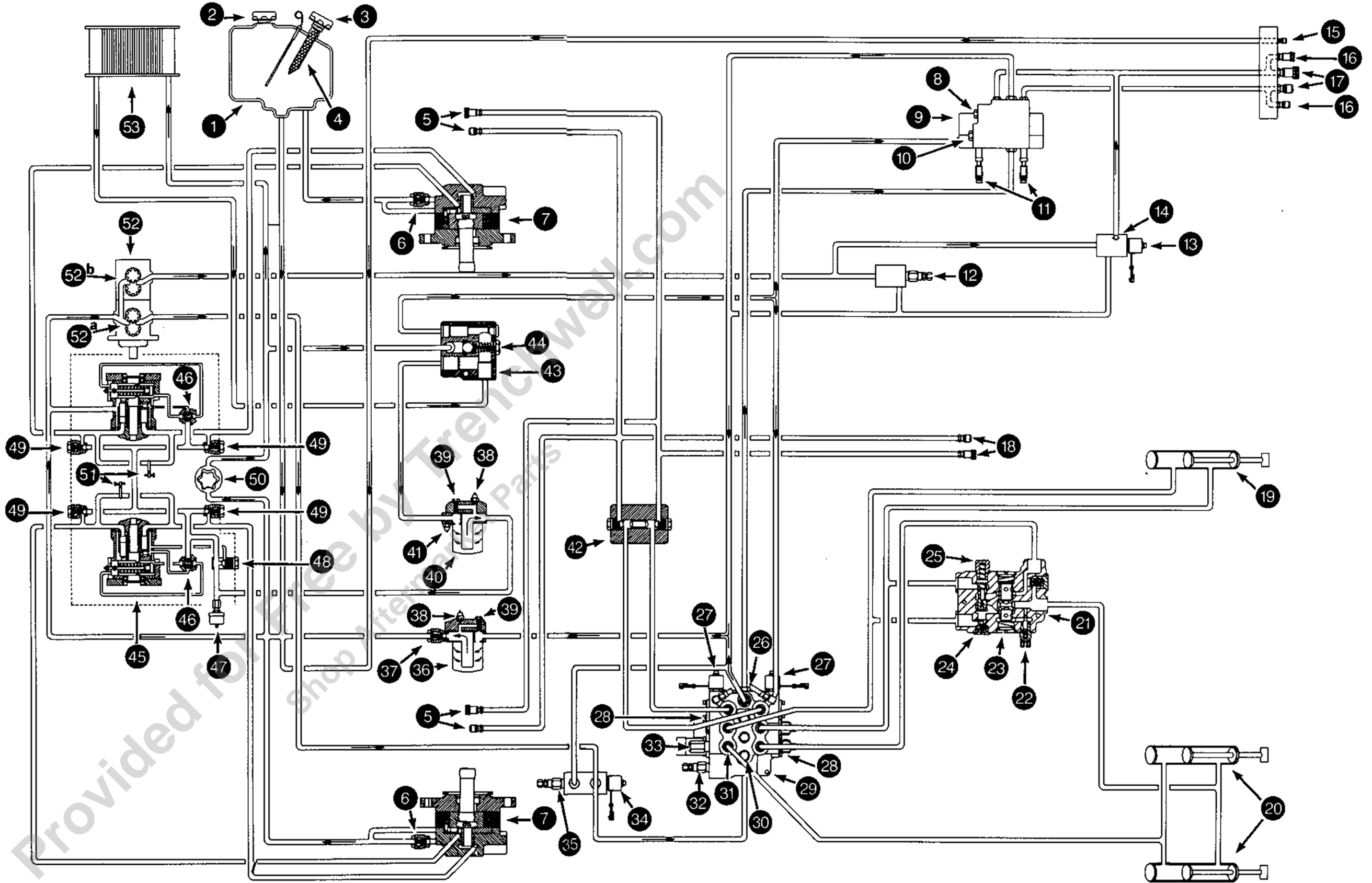

MC 1554

HYDRAULIC/HYDROSTATIC SCHEMATIC

853 (S/N 508411001-15215)

(S/N 510125001-26791)

(S/N 510250001-50691)

(Printed June 1999)

MC2396LU

LEGEND

- | | | | |
|--|---|--|---|
| ① RESERVOIR:
Capacity . . . 15.5 Qts (14,7 L) | ⑬ RELIEF VALVE - PORT:
3500 PSI (24132 kPa) | ⑳ FILTER | ㉟ FIXED CAPACITY DISPLACEMENT
BIDIRECTIONAL HYDROSTATIC
MOTOR |
| ② SPRING LOADED FILTER BYPASS
VALVE: 45-55 PSI (311-379 kPa) | ⑭ LOAD CHECK VALVE | ㉑ RELIEF VALVE - CHARGE:
140°F. (60°C.) Fluid at Full RPM
Neutral 310-330 PSI
(2137-2275 kPa) | ㉠ ANTICAVITATION VALVE |
| ③ DIFFERENTIAL PRESSURE SWITCH:
36-44 PSI (248-303 kPa)
853 PLUS - Normally Closed
853 BASE - Normally Closed | ⑮ ONE WAY RESTRICTOR VALVE | ㉒ Stroked 300-320 PSI
(2069-2206 kPa) | ㉡ PILOT TO OPEN CHECK VALVE |
| ④ CHECK VALVE - FILTER | ⑯ RELIEF VALVE - MAIN:
2550-2600 PSI (17582-17927 kPa)
at Front Quick Couplers | ㉓ MUFFLER (If Equipped) | ㉢ FILTER |
| ⑤ FLOW DIVIDER ADJUSTMENT VALVE | ⑰ SHUTTLE RELIEF VALVE:
225-290 PSI (1551-2000 kPa) | ㉔ CHARGE PRESSURE SENSOR | |
| ⑥ PILOT ACTIVATED DIRECTIONAL
CONTROL VALVE - FLOW CONTROL
SPOOL | ⑱ DRIVE MOTOR SHUTTLE VALVE | ㉕ FLUID TEMPERATURE SENSOR | |
| ⑦ PILOT ACTIVATED DIRECTIONAL
CONTROL VALVE - UNLOADING
SPOOL | ㉒ TOW VALVE | ㉖ BYPASS VALVE - COLD OIL
85 PSI (596 kPa) | |
| ⑧ CONTROL VALVE POWER-BEYOND
OUTLET | ㉓ RELIEF/REPLENISHING VALVE - HIGH
PRESSURE:
STANDARD . 4350 PSI (29990 kPa)
OPTIONAL . 5000 PSI (34475 kPa) | ㉗ SOLENOID ACTIVATED DIRECTIONAL
CONTROL VALVE - FRONT
AUXILIARY (OPTIONAL ON 853 BASE) | |
| ⑨ RELIEF VALVE - PORT: (OPTIONAL)
3100 PSI (21371 kPa) | ㉔ DISPLACEMENT CONTROL VALVE | ㉘ SOLENOID ACTIVATED DIRECTIONAL
CONTROL VALVE (TWO COIL) | |
| ⑩ SOLENOID ACTIVATED DIRECTIONAL
CONTROL VALVE - AUXILIARY
(OPTIONAL) | ㉕ CHARGE PUMP 11.0 GPM
(41,6 L./M in.) at 2850 RPM | ㉙ FILTER | |
| ⑪ CHECK VALVE - BUCKET POSITION
VALVE | ㉖ HYDRAULIC PUMP
18.0 GPM (68,1 L/min.)
at 2750 RPM | ㉚ RELIEF VALVE - FRONT AUXILIARY
2400-2600 PSI (16548-17927 kPa) | |
| ⑫ RELIEF/ANTICAVITATION VALVE -
PORT (TILT BASE END) (OPTIONAL):
2500 PSI (17238 kPa) | | ㉛ FILTER - HYDROSTATIC (CANISTER) | |
| | | ㉜ RESTRICTION | |
| | | ㉝ FILTER - HYDRAULIC (CANISTER) | |

NOTE: Unless otherwise specified
springs have NO significant
pressure value.

HYDRAULIC/HYDROSTATIC SCHEMATIC
853 (S/N 508411001-15215)
(S/N 510125001-26791)
(S/N 510250001-50691)
(Printed June 1999)
MC2396U

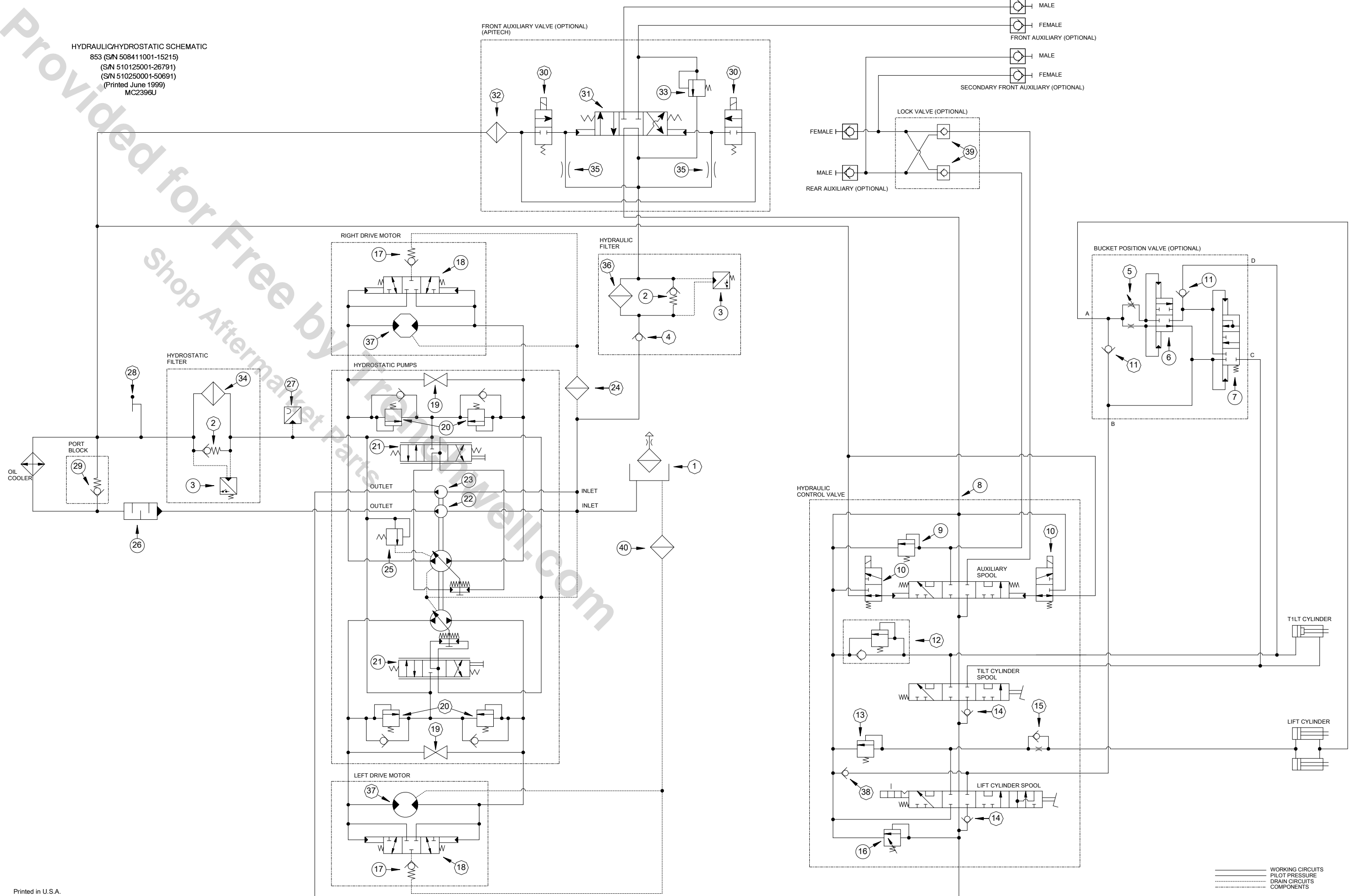

——— WORKING CIRCUITS
 - - - PILOT PRESSURE
 ····· DRAIN CIRCUITS
 □ COMPONENTS

HYDRAULIC/HYDROSTATIC SCHEMATIC

853 (S/N 508415216-17999)
 (S/N 510126792 AND ABOVE)
 (S/N 510250692 AND ABOVE)
 (S/N 512811001-15999)

(Printed June 1999)
 MC2397LU

LEGEND

- ① RESERVOIR:
C capacity . . . 15.5 Qts (14,7 L)
- ② SPRING LOADED FILTER BYPASS VALVE: 45-55 PSI (311-379 kPa)
- ③ DIFFERENTIAL PRESSURE SWITCH:
36-44 PSI (248-303 kPa)
853 PLUS - Normally Closed
853 BASE - Normally Closed
- ④ CHECK VALVE - FILTER
- ⑤ FLOW DIVIDER ADJUSTMENT VALVE
- ⑥ PILOT ACTIVATED DIRECTIONAL CONTROL VALVE - FLOW CONTROL SPOOL
- ⑦ PILOT ACTIVATED DIRECTIONAL CONTROL VALVE - UNLOADING SPOOL
- ⑧ PILOT ACTIVATED DIRECTIONAL CONTROL VALVE - FOR REAR AUXILIARY - NORMALLY OPEN ("D2")
- ⑨ RELIEF VALVE - PORT: (OPTIONAL)
3100 PSI (21371 kPa)
- ⑩ SOLENOID ACTIVATED DIRECTIONAL CONTROL VALVE - AUXILIARY (OPTIONAL)
- ⑪ CHECK VALVE - BUCKET POSITION VALVE
- ⑫ RELIEF/ANTICAVITATION VALVE - PORT (TILT BASE END):
2500 PSI (17238 kPa)
- ⑬ RELIEF VALVE - PORT:
3500 PSI (24132 kPa)
- ⑭ LOAD CHECK VALVE
- ⑮ ONE WAY RESTRICTOR VALVE
- ⑯ RELIEF VALVE - MAIN:
2550-2600 PSI (17582-17927 kPa)
at Front Quick Couplers
- ⑰ SHUTTLE RELIEF VALVE:
225-290 PSI (1551-2000 kPa)
- ⑱ DRIVE MOTOR SHUTTLE VALVE
- ⑲ TOW VALVE
- ⑳ RELIEF/REPLENISHING VALVE - HIGH PRESSURE:
STANDARD . 4350 PSI (29990 kPa)
OPTIONAL . 5000 PSI (34475 kPa)
- ㉑ DISPLACEMENT CONTROL VALVE
- ㉒ CHARGE PUMP 11.0 GPM (41,6 L./M in.) at 2850 RPM
- ㉓ HYDRAULIC PUMP
18.0 GPM (68,1 L/min.)
at 2750 RPM
- ㉔ FILTER
- ㉕ RELIEF VALVE - CHARGE:
140°F. (60°C.) Fluid at Full RPM
Neutral 310-330 PSI (2137-2275 kPa)
Stroked 300-320 PSI (2069-2206 kPa)
- ㉖ MUFFLER (if Equipped)
- ㉗ CHARGE PRESSURE SENSOR
- ㉘ FLUID TEMPERATURE SENSOR
- ㉙ PILOT ACTIVATED DIRECTIONAL CONTROL VALVE - FOR REAR AUXILIARY - NORMALLY OPEN ("D1")
- ㉚ SOLENOID ACTIVATED DIRECTIONAL CONTROL VALVE - FRONT AUXILIARY (OPTIONAL ON 853 BASE)
- ㉛ PILOT ACTIVATED DIRECTIONAL CONTROL VALVE - FOR REAR AUXILIARY - NORMALLY CLOSED ("P1" and "F1")
- ㉜ FILTER
- ㉝ SOLENOID ACTIVATED DIRECTIONAL CONTROL VALVE
- ㉞ FILTER - HYDROSTATIC (CANISTER)
- ㉟ PILOT ACTIVATED DIRECTIONAL CONTROL VALVE - FOR REAR AUXILIARY - NORMALLY CLOSED ("P2" and "F2")
- ㊱ FILTER - HYDRAULIC (CANISTER)
- ㊲ FILTER
- ㊳ FIXED CAPACITY DISPLACEMENT BIDIRECTIONAL HYDROSTATIC MOTOR
- ㊴ ANTICAVITATION VALVE

NOTE: Unless otherwise specified, springs have NO significant pressure value.

HYDRAULIC/HYDROSTATIC SCHEMATIC
 853 (S/N 508415216-17999)
 (S/N 510126792 AND ABOVE)
 (S/N 510250692 AND ABOVE)
 (S/N 512811001-15999)
 (Printed June 1999)
 MC2397U

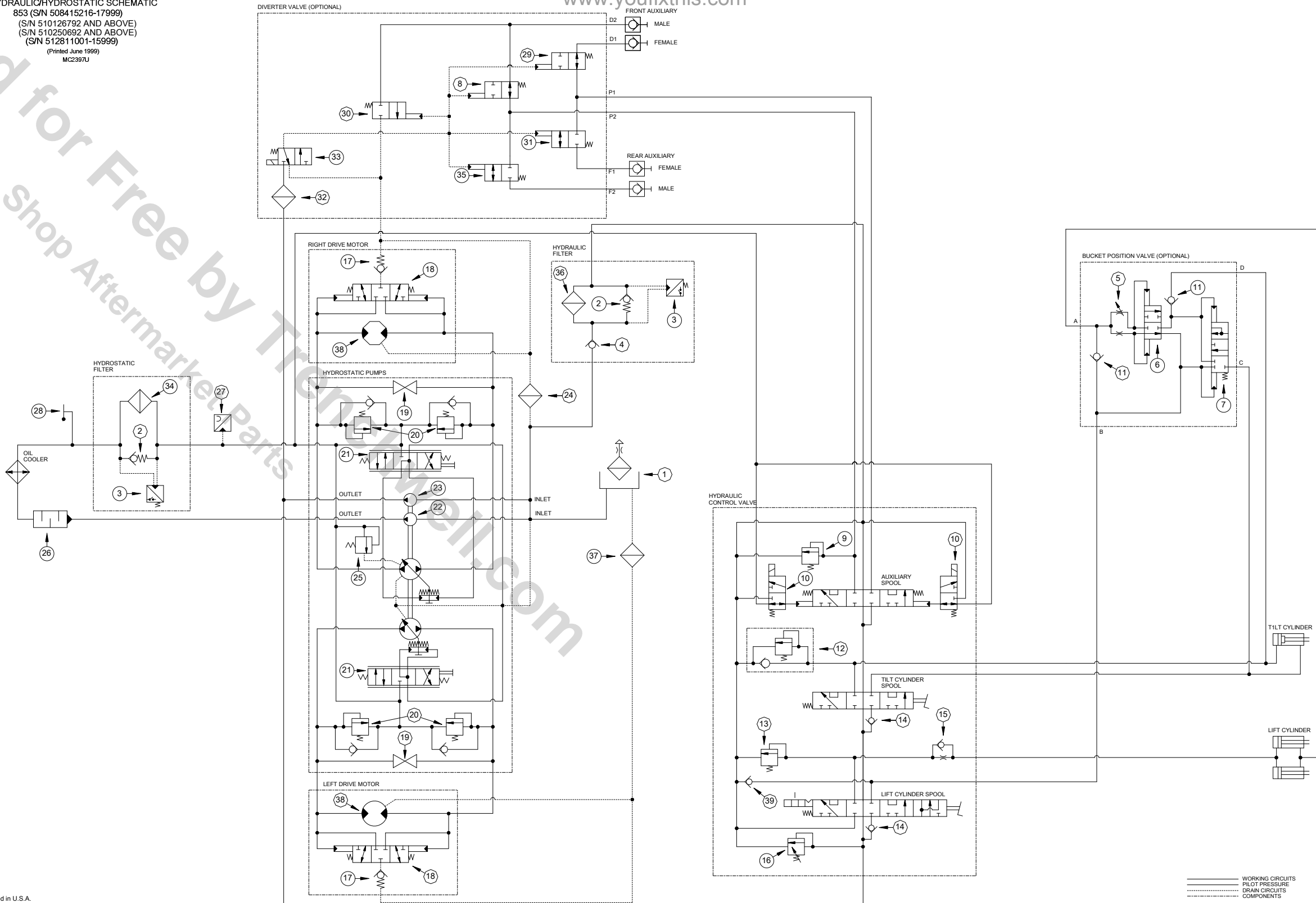

————— WORKING CIRCUITS
 - - - - - PILOT PRESSURE
 ······ DRAIN CIRCUITS
 ······ COMPONENTS

HYDRAULIC/HYDROSTATIC SCHEMATIC

HI-FLOW MACHINE

853 (S/N 510375001 AND ABOVE)

(S/N 509711001-17999)

(S/N 512811001-15999 WITH APITECH AUXILIARY VALVE)

(Printed June 1999)

MC2398LU

LEGEND

- | | | | |
|--|---|--|--|
| ① RESERVOIR:
Capacity . . . 15.5 Qts (14,7 L) | ⑬ RELIEF VALVE - PORT:
3500 PSI (24132 kPa) | ⑳ FILTER - HYDRAULIC (CANISTER) | ㉟ FIXED CAPACITY DISPLACEMENT
BIDIRECTIONAL HYDROSTATIC
MOTOR |
| ② SPRING LOADED FILTER BYPASS
VALVE: 45-55 PSI (311-379 kPa) | ⑭ LOAD CHECK VALVE | ㉑ RELIEF VALVE - CHARGE:
140°F. (60°C.) Fluid at Full RPM
Neutral 310-330 PSI
(2137-2275 kPa) | ㉒ ANTICAVITATION VALVE |
| ③ DIFFERENTIAL PRESSURE SWITCH:
36-44 PSI (248-303 kPa)
853 PLUS - Normally Closed
853 BASE - Normally Closed | ⑮ ONE WAY RESTRICTOR VALVE | ㉒ Stroked 300-320 PSI
(2069-2206 kPa) | ㉓ HYDRAULIC PUMP
6.0 GPM (22,7 L/ min.)
2750 RPM at
1150 PSI (7929 kPa) |
| ④ CHECK VALVE - FILTER | ⑯ RELIEF VALVE - MAIN:
3300 PSI (22750 kPa)
at 18 GPM (68,1 L/ min.) | ㉔ MUFFLER (If Equipped) | ㉔ SOLENOID ACTIVATED DIRECTIONAL
CONTROL VALVE - FLOW
SELECTIVE VALVE |
| ⑤ FLOW DIVIDER ADJUSTMENT VALVE | ⑰ SHUTTLE RELIEF VALVE:
225-290 PSI (1551-2000 kPa) | ㉕ CHARGE PRESSURE SENSOR | ㉕ CHECK VALVE - FLOW SELECTIVE
VALVE |
| ⑥ PILOT ACTIVATED DIRECTIONAL
CONTROL VALVE - FLOW CONTROL
SPOOL | ⑱ DRIVE MOTOR SHUTTLE VALVE | ㉖ FLUID TEMPERATURE SENSOR | ㉖ RELIEF VALVE
3200-3400 PSI (22061-23439 kPa) |
| ⑦ PILOT ACTIVATED DIRECTIONAL
CONTROL VALVE - UNLOADING
SPOOL | ⑲ TOW VALVE | ㉗ BYPASS VALVE - COLD OIL
85 PSI (596 kPa) | ㉗ SOLENOID ACTIVATED DIRECTIONAL
CONTROL VALVE - RELIEF
SELECTIVE VALVE |
| ⑧ CONTROL VALVE POWER-BEYOND
OUTLET | ㉘ RELIEF/REPLENISHING VALVE - HIGH
PRESSURE:
STANDARD . 4350 PSI (29990 kPa)
OPTIONAL . 5000 PSI (34475 kPa) | ㉘ SOLENOID ACTIVATED DIRECTIONAL
CONTROL VALVE - FRONT
AUXILIARY (OPTIONAL ON 853 BASE) | ㉘ RELIEF VALVE
2750-2850 PSI (18958-19648 kPa) |
| ⑨ RELIEF VALVE - PORT: (OPTIONAL)
3100 PSI (21371 kPa) | ㉙ DISPLACEMENT CONTROL VALVE | ㉙ SOLENOID ACTIVATED DIRECTIONAL
CONTROL VALVE (TWO COIL) | ㉙ PILOT TO OPEN CHECK VALVE |
| ⑩ SOLENOID ACTIVATED DIRECTIONAL
CONTROL VALVE - REAR
AUXILIARY (OPTIONAL) | ㉚ CHARGE PUMP 11.0 GPM
(41,6 L/M in.) at 2850 RPM | ㉚ FILTER | ㉚ FILTER |
| ⑪ CHECK VALVE - BUCKET POSITION
VALVE | ㉛ HYDRAULIC PUMP
18.0 GPM (68,1 L/ min.)
2750 RPM at
1150 PSI (7929 kPa) | ㉛ RELIEF VALVE - FRONT AUXILIARY
(OPTIONAL) . 2500 PSI (17235 kPa) | |
| ⑫ RELIEF/ANTICAVITATION VALVE -
PORT (TILT BASE END) (OPTIONAL)
2500 PSI (17238 kPa) | | ㉛ FILTER - HYDROSTATIC (CANISTER) | |
| | | ㉜ RESTRICTION | |

NOTE: Unless otherwise specified
springs have NO significant
pressure value.

HYDRAULIC/HYDROSTATIC SCHEMATIC
HI-FLOW MACHINE
853 (S/N 510375001 AND ABOVE)
(S/N 509711001-17999)
(S/N 512811001-15999 WITH APITECH AUXILIARY VALVE)
(Printed June 1999)
MC2398U

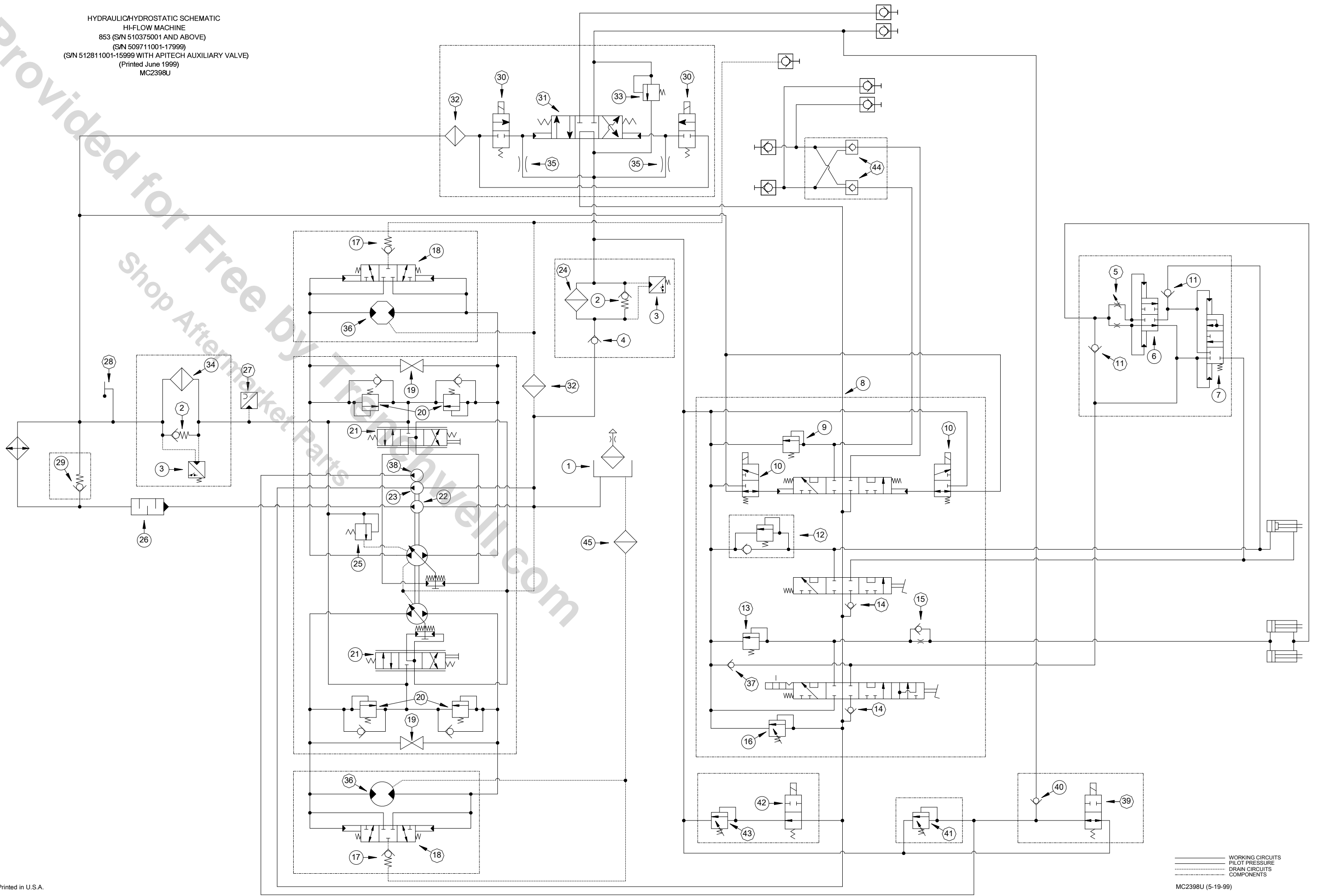

WORKING CIRCUITS
PILOT PRESSURE
DRAIN CIRCUITS
COMPONENTS

MC2398U (5-19-99)

HYDRAULIC/HYDROSTATIC SCHEMATIC

HI-FLOW MACHINE

853 (S/N 512811001-15999 WITH JEM AUXILIARY VALVE)

(Printed June 1999)

MC2399LU

LEGEND

- | | | | |
|--|--|--|---|
| ① RESERVOIR:
Capacity . . . 16.0 Qts (15,1 L) | ⑫ RELIEF VALVE - PORT:
3500 PSI (24132 kPa) | ⑳ CHARGE PUMP . 14.0-15.0 GPM
(52,9-56,7 L/ min.) at 2700 RPM | ㉔ FIXED CAPACITY DISPLACEMENT
BIDIRECTIONAL HYDROSTATIC
MOTOR |
| ② SPRING LOADED FILTER BYPASS
VALVE: 45-55 PSI (311-379 kPa) | ⑬ LOAD CHECK VALVE | ㉕ FILTER | ㉕ ANTICAVITATION VALVE |
| ③ DIFFERENTIAL PRESSURE SWITCH:
36-44 PSI (248-303 kPa)
Standard Loader - Normally Open
B.O.S.S. Loader - Normally Closed | ⑭ ONE WAY RESTRICTOR VALVE | ㉖ RELIEF VALVE - CHARGE:
140°F. (60°C.) Fluid at Full RPM
Neutral 310-330 PSI
(2137-2275 kPa)
Stroked 300-320 PSI
(2069-2206 kPa) | ㉖ FILTER |
| ④ CHECK VALVE - FILTER | ⑮ RELIEF VALVE - MAIN:
at Front Quick Couplers
SYSTEM MAIN RELIEF:
2800 PSI (19306 kPa)
HI FLOW MAIN RELIEF:
3300 PSI (22754 kPa) | ㉗ MUFFLER (If Equipped) | |
| ⑤ FLOW DIVIDER ADJUSTMENT VALVE | ⑯ SHUTTLE RELIEF VALVE:
290 PSI (2000 kPa) | ㉘ CHARGE PRESSURE SENSOR | |
| ⑥ PILOT ACTIVATED DIRECTIONAL
CONTROL VALVE - FLOW CONTROL
SPOOL | ⑰ DRIVE MOTOR SHUTTLE VALVE | ㉙ FLUID TEMPERATURE SENSOR | |
| ⑦ PILOT ACTIVATED DIRECTIONAL
CONTROL VALVE - UNLOADING
SPOOL | ⑱ TOW VALVE | ㉚ PILOT TO OPEN CHECK VALVE | |
| ⑧ RELIEF VALVE - PORT: (OPTIONAL)
2500 PSI (17238 kPa) | ⑲ RELIEF/REPLENISHING VALVE - HIGH
PRESSURE:
STANDARD . 4350 PSI (29990 kPa)
OPTIONAL . 5000 PSI (34475 kPa) | ㉛ SOLENOID ACTIVATED DIRECTIONAL
CONTROL VALVE - FRONT
AUXILIARY | |
| ⑨ SOLENOID ACTIVATED DIRECTIONAL
CONTROL VALVE - AUXILIARY | ㉔ DISPLACEMENT CONTROL VALVE | ㉜ RELIEF VALVE - MAIN HIGH FLOW
3000 PSI (20685 kPa) | |
| ⑩ CHECK VALVE - BUCKET POSITION
VALVE | ㉕ AUXILIARY HYDRAULIC PUMP:
6.0 GPM (22,7 L/ min.)
at 2750 RPM
at 1150 PSI (7929 kPa) | ㉝ RESTRICTION | |
| ⑪ RELIEF/ANTICAVITATION VALVE -
PORT (TILT BASE END) (OPTIONAL)
2500 PSI (17238 kPa) | ㉖ HYDRAULIC PUMP . . . Gear Type
PUMP CAPACITY:
18.0 GPM (68,1 L/min.)
HI FLOW CAPACITY: (Includes ㉗)
24.0 GPM (90,8 L/ min.)
at 2750 RPM
at 1150 PSI (7929 kPa) | ㉞ SOLENOID ACTIVATED DIRECTIONAL
CONTROL VALVE | |
| | | ㉞ SOLENOID ACTIVATED DIRECTIONAL
CONTROL VALVE (TWO COIL) | |
| | | ㉟ FILTER - HYDROSTATIC (CANISTER) | |
| | | ㊱ FILTER - HYDRAULIC (CANISTER) | |
| | | ㊲ COLD OIL BYPASS VALVE | |

NOTE: Unless otherwise specified
springs have NO significant
pressure value.

HYDRAULIC/HYDROSTATIC SCHEMATIC
HI-FLOW MACHINE
853 (S/N 512811001 AND ABOVE WITH JEM AUXILIARY VALVE)
(Printed June 1999)
MC2399U

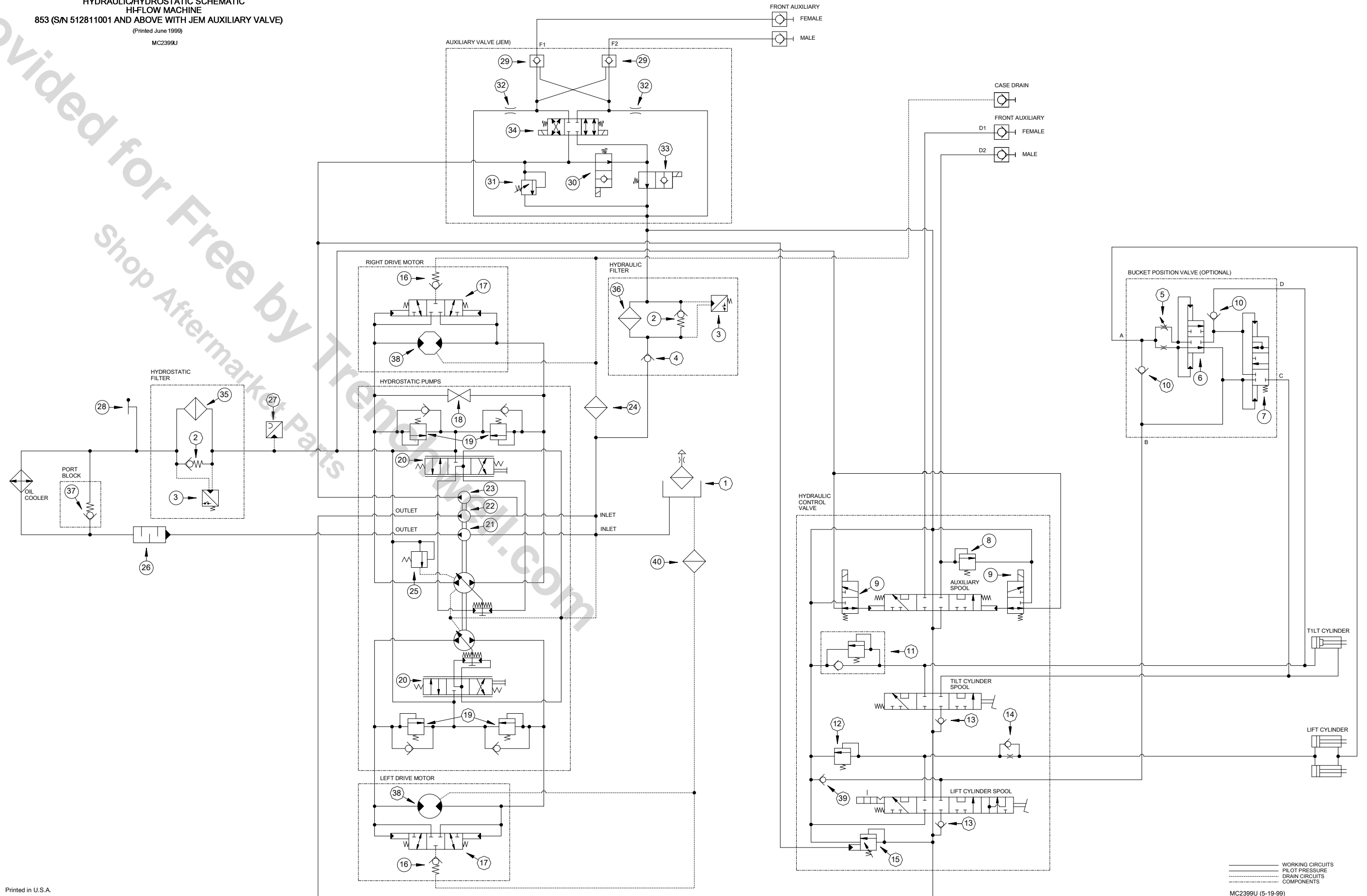

——— WORKING CIRCUITS
 - - - PILOT PRESSURE
 ····· DRAIN CIRCUITS
 - - - COMPONENTS

TROUBLESHOOTING**Chart**

The following troubleshooting chart is provided for assistance in locating and correcting problems which are most common. Many of the recommended procedures must be done by authorized Bobcat Service Personnel only.

**WARNING**

Check for correct function after adjustments, repairs or service. Failure to make correct repairs or adjustments can cause injury or death.

W-2004-1285

PROBLEM	CAUSE
The hydraulic system will not operate.	1, 2, 3, 5
The transmission warning light comes ON when hydraulics are operating. (853 Base)	1, 3
Slow hydraulic system action.	1, 3, 4, 5, 6, 8
Hydraulic action is not smooth.	1, 4, 5, 6, 7
Lift arms go up slowly at full engine RPM.	1, 3, 4, 5, 6, 7, 8, 9
The lift arms or Bob-Tach will move the pedal in neutral position.	4
The lift arms come down with the pedal in the neutral position.	4, 9, 10, 11

KEY TO CORRECT THE CAUSE

1. The fluid level is not correct.
2. The pedal linkage is disconnected.
3. The hydraulic pump has damage.
4. The pedal linkage is not adjusted correctly.
5. Relief valve is not at the correct pressure.
6. Suction leak on the inlet side of the hydraulic pump.
7. Fluid is cold. Wrong viscosity fluid. (See Section 9.)
8. Using the loader for more than its rated capacity.
9. Internal leak in the lift cylinder(s).
10. External leak from the lift cylinder(s).
11. Damaged lift spool.

HYDRAULIC SYSTEM INFORMATION

IMPORTANT

When repairing hydrostatic and hydraulic systems, clean the work area before disassembly and keep all parts clean. Always use caps and plugs on hoses, tubelines and ports to keep dirt out. Dirt can quickly damage the system.

I-2003-0888

Tighten Procedures

For tightening torques for hydraulic fittings, tubelines etc., See Section 9. – *Hydraulic Connection Specifications*.

WARNING

Hydraulic fluid escaping under pressure can have sufficient force to enter a person's body by penetrating the skin. This can cause serious injury and possibly death if proper medical treatment by a physician familiar with this injury is not received immediately.

W-2145-0290

LIFT CYLINDER(S)**Checking The Lift Cylinder**

Lower the lift arms. Stop the engine. Raise the seat bar.

**WARNING**

Diesel fuel or hydraulic fluid under pressure can penetrate skin or eyes, causing serious injury or death. Fluid leaks under pressure may not be visible. Use a piece of cardboard or wood to find leaks. Do not use your bare hand. Wear safety goggles. If fluid enters skin or eyes, get immediate medical attention from a physician familiar with this injury.

W-2072-0496

Check only one cylinder at a time. Disconnect the hose (Item 1) [A] which goes to the base end of the lift cylinder.

Install a plug (Item 1) [B] in the hose and tighten.

Engage the parking brake. Lower the seat bar. Start the engine and push the top (toe) of the lift pedal.

If there is any leakage from the open port, remove the lift cylinder for repair. Repeat the procedure to check the other lift cylinder.

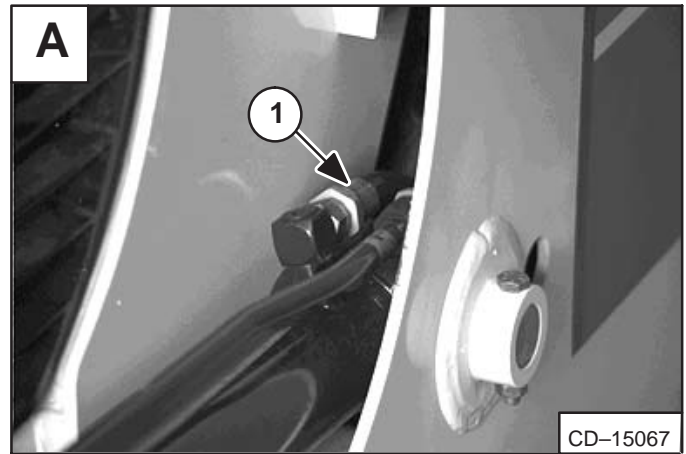

CD-15067

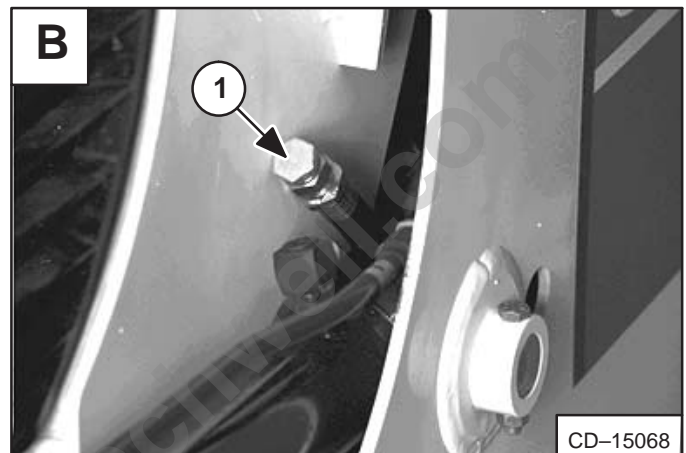

CD-15068

Removal And Installation

Engage the parking brake.

Raise the lift arms so the rod end retaining pin will clear the loader frame for removal.

Have a second person put jackstands under the Bob-Tach to support the lift arms [C]. Stop the engine.

Raise the operator cab. (See Page 1-1.)

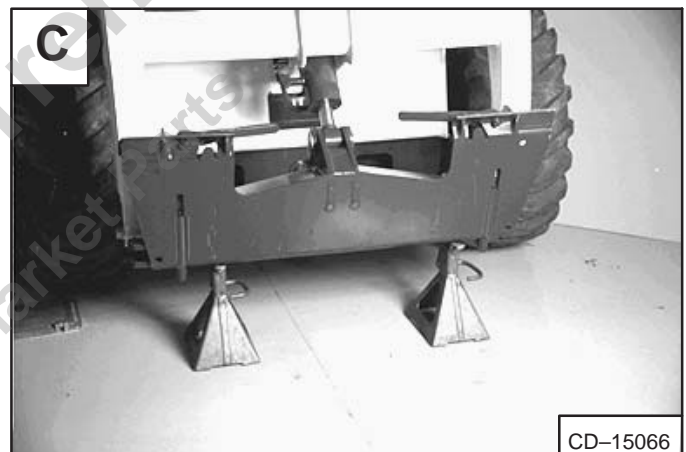

CD-15066

Remove the retaining bolt and nut (Item 1) [D] from the retaining pin on the rod end of the cylinder.

Installation: Tighten the retainer bolt and nut to 18–20 ft.-lbs. (24–27 Nm) torque.

Remove the retaining pin from the rod end of the cylinder.

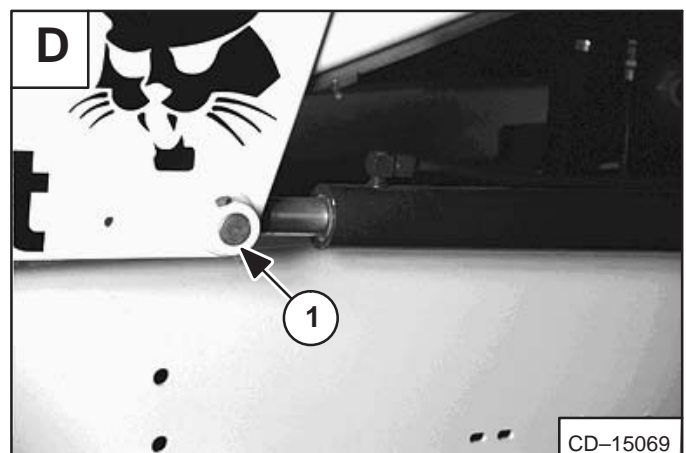

CD-15069

LIFT CYLINDER(S) (Cont'd)**Removal And Installation (Cont'd)**

Remove the retaining bolt and nut (Item 1) [A] from the retaining pin on the base end of the cylinder.

Installation: Tighten the retainer bolt and nut to 18–20 ft.-lbs. (24–27 Nm) torque.

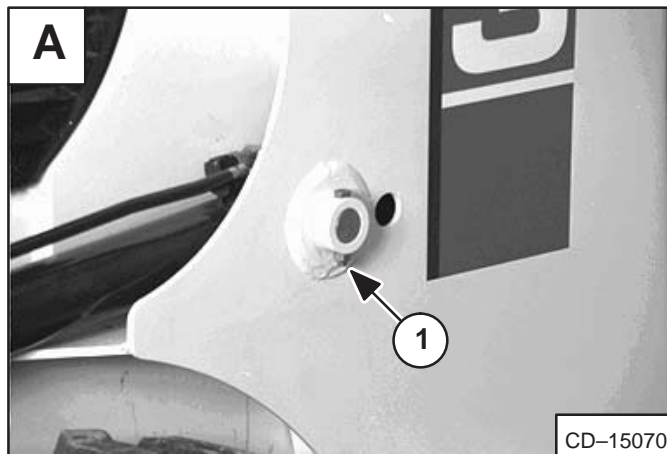

Remove the retaining pin from the base end of the cylinder [B].

Slide the cylinder forward for clearance to disconnect the hoses.



Mark the hoses for correct installation.

Disconnect the two hoses (Item 1) [C] from the lift cylinder.

Remove the lift cylinder.

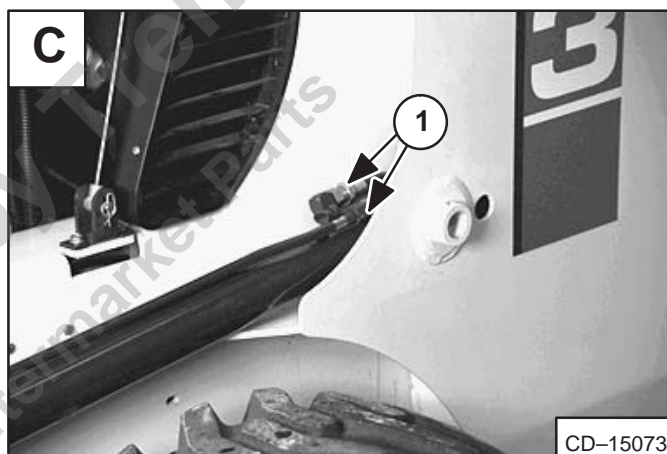
**WARNING**

Always clean up spilled fuel or oil. Keep heat, flames, sparks or lighted tobacco away from fuel and oil. Failure to use care around combustibles can cause explosion or fire which can result in injury or death.

W-2103-1285

TILT CYLINDER

Checking The Tilt Cylinder

Remove the attachment. Roll the Bob-Tach fully back. Stop the engine. Raise the seat bar.

! WARNING

Diesel fuel or hydraulic fluid under pressure can penetrate skin or eyes, causing serious injury or death. Fluid leaks under pressure may not be visible. Use a piece of cardboard or wood to find leaks. Do not use your bare hand. Wear safety goggles. If fluid enters skin or eyes, get immediate medical attention from a physician familiar with this injury.

W-2072-0496

Disconnect the hose (Item 1) [A] which goes to the base end of the tilt cylinder.

Put a plug in the hose and tighten.

Connect a hose between cylinder port and into a drain pan.

Engage the parking brake. Lower the seat bar. Start the engine and push the bottom (heel) of the tilt pedal. If there is leakage from the open port, remove the tilt cylinder for repair.

Removal And Installation

Remove the attachment. Roll the Bob-Tach fully forward [B].

Stop the engine. Raise the seat bar.

Disconnect both hydraulic hoses (Items 1 & 2) [A].

Remove the retainer bolt and nut (Item 1) [C] from the rod end pivot pin.

Installation: Tighten the retainer nut to 18–20 ft.-lbs. (24–27 Nm) torque.

Remove the grease fitting from the rod end pivot pin.

Remove the rod end pivot pin (Item 1) [D].

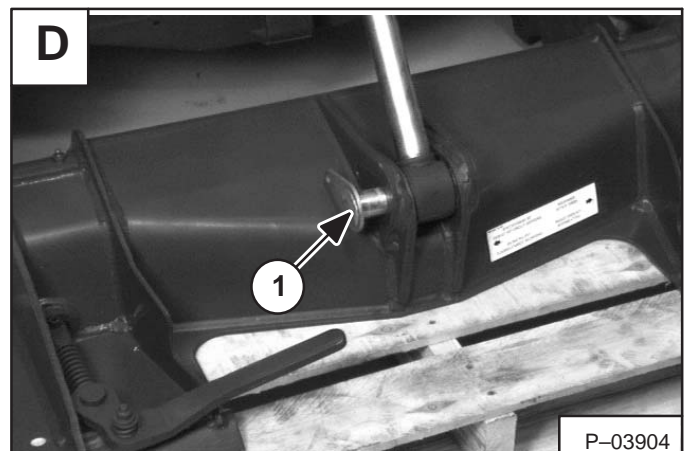
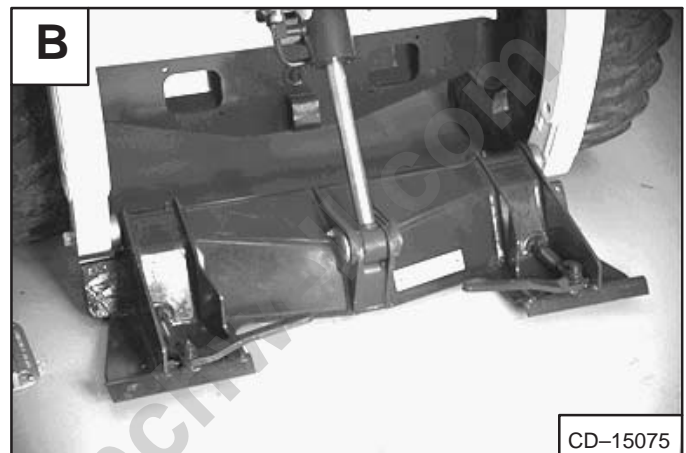
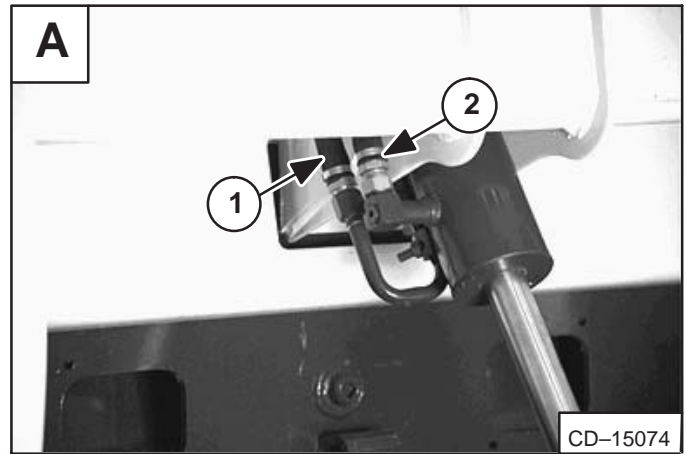

TILT CYLINDER (Cont'd)**Removal And Installation (Cont'd)**

Remove the retainer bolt and nut (Item 1) [A] from the base end pivot pin.

Installation: Tighten the retainer nut and bolt to 18–20 ft.-lbs. (24–27 Nm) torque.

**WARNING**

Always clean up spilled fuel or oil. Keep heat, flames, sparks or lighted tobacco away from fuel and oil. Failure to use care around combustibles can cause explosion or fire which can result in injury or death.

W-2103-1285

Remove the base end pivot pin (Item 1) [B].

Remove the tilt cylinder from the loader.

Rod End Seal

Remove the old seal (both sides) from the rod end of the tilt cylinder.

Install the new seals with the lip facing out [C].

Use two pieces of shim stock to protect the new seals during installation.

Install the rod end of the tilt cylinder into the Bob-Tach [D].

Be careful not to damage the new seals during installation.

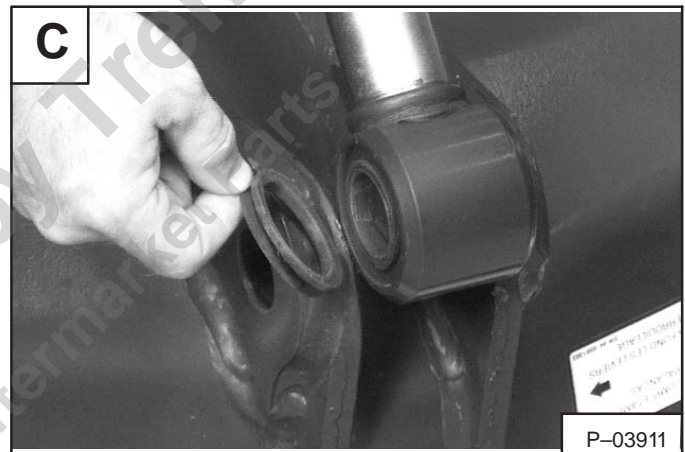
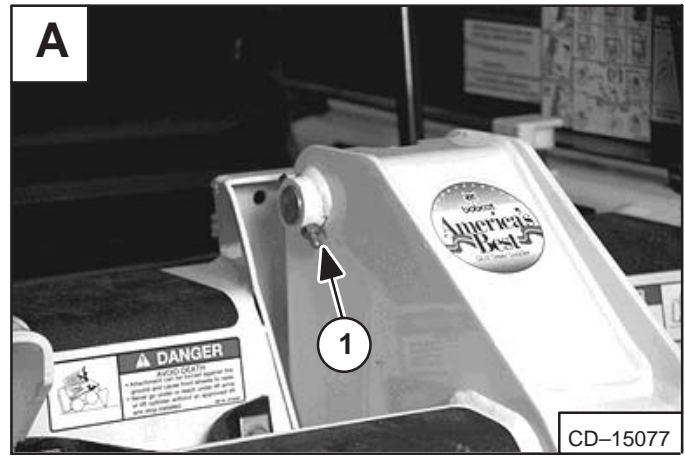

HYDRAULIC CYLINDER

Lift Cylinder Identification

- | | |
|-----------|------------|
| 1. Tube | 9. O-ring |
| 2. O-ring | 10. Spacer |
| 3. Plug | 11. O-ring |
| 4. Case | 12. Washer |
| 5. O-ring | 13. Head |
| 6. Nut | 14. Seal |
| 7. Piston | 15. Seal |
| 8. Ring | 16. Rod |

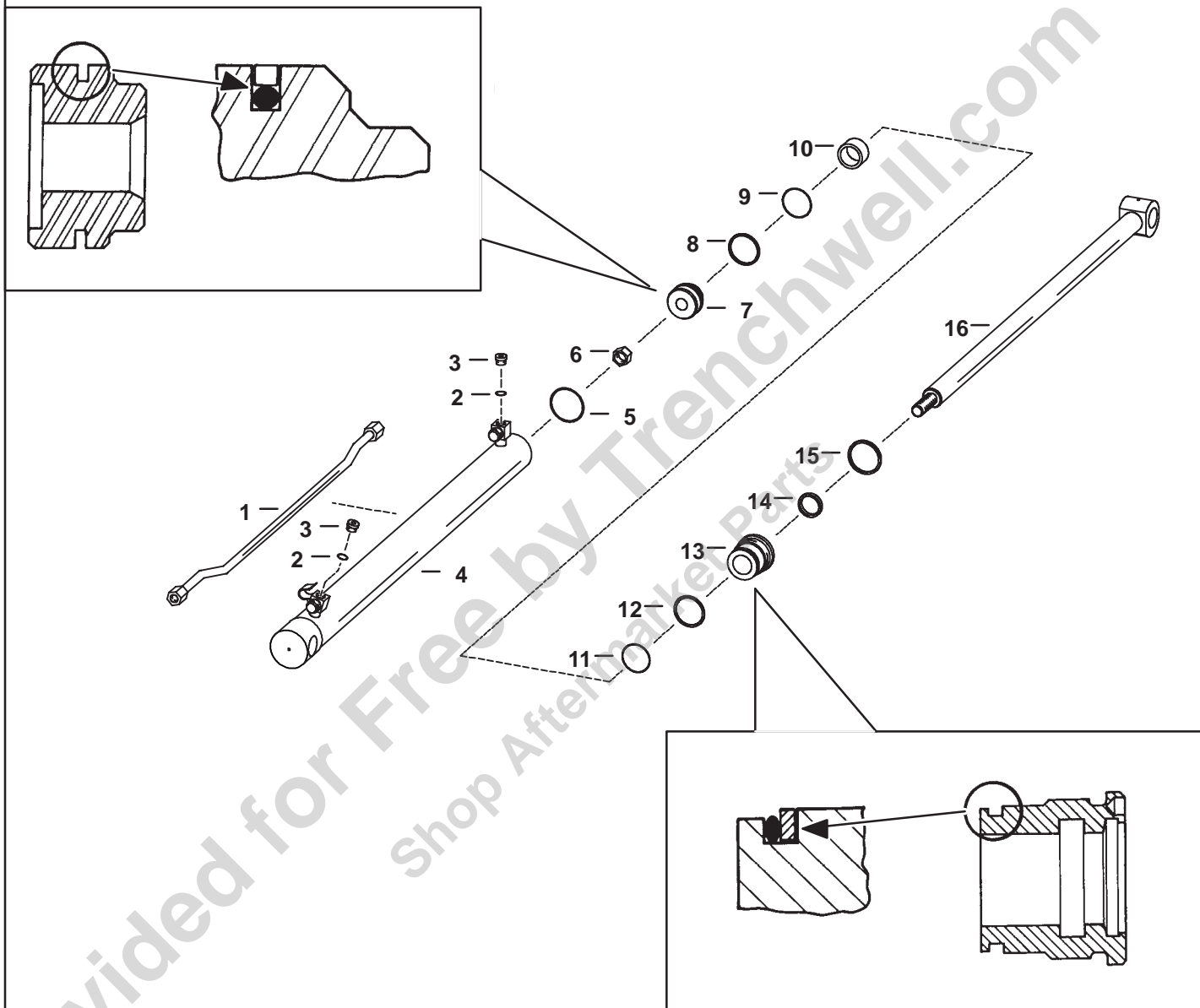

TS-01060

HYDRAULIC CYLINDER (Cont'd)

Tilt Cylinder Identification

- | | |
|------------|-------------|
| 1. Case | 11. Seal |
| 2. Tube | 12. Washer |
| 3. Plug | 13. O-ring |
| 4. O-ring | 14. Head |
| 5. Clamp | 15. Seal |
| 6. Nut | 16. Seal |
| 7. Nut | 17. Rod |
| 8. Piston | 18. Bushing |
| 9. Seal | |
| 10. O-ring | |

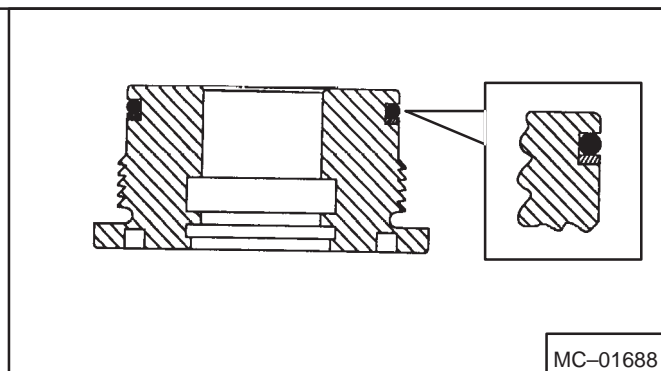

MC-01688

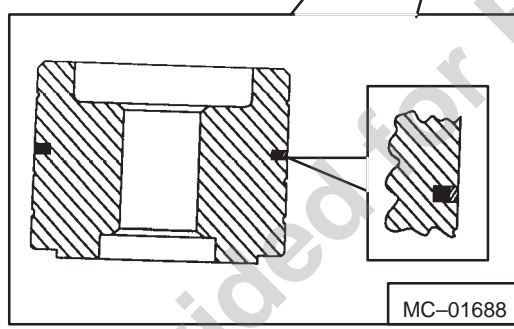
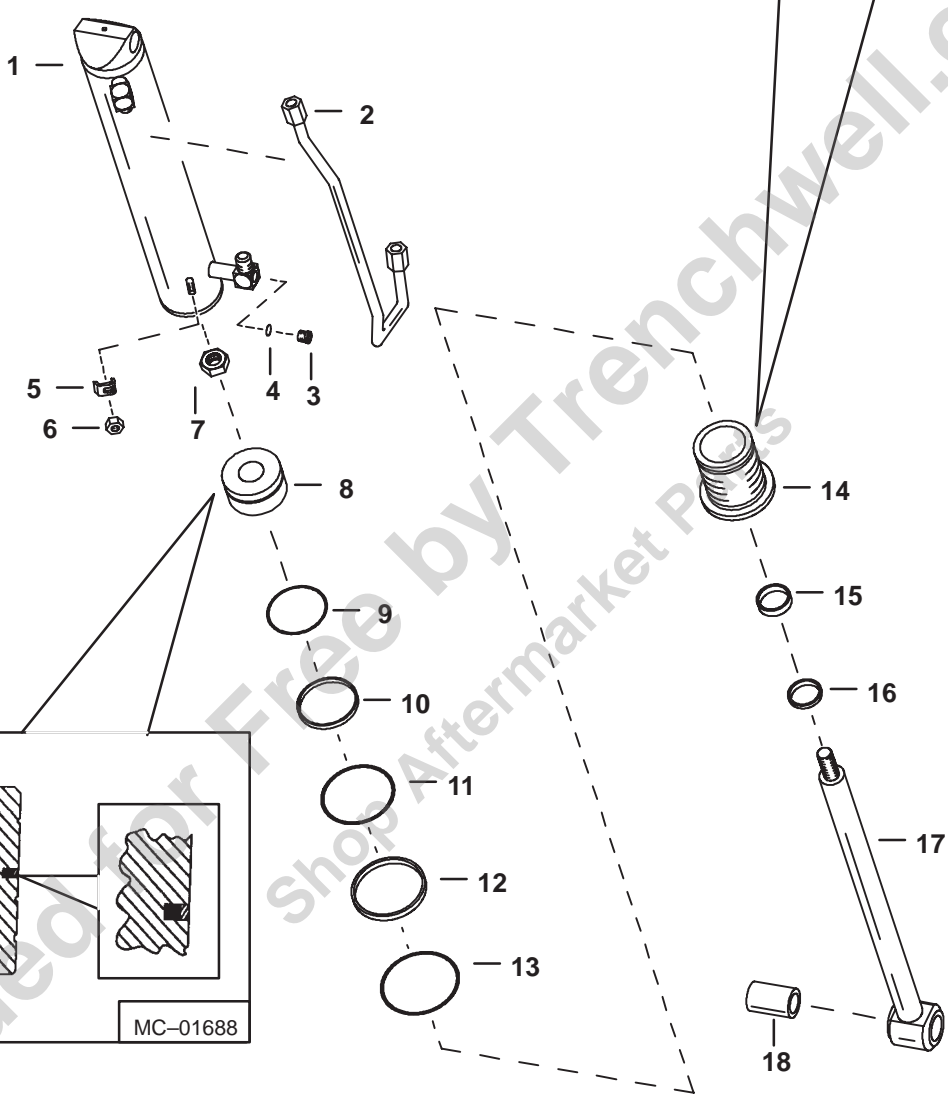

MC-01688

TS-01098

HYDRAULIC CYLINDERS (Cont'd)**Disassembly**

Use the following tools to disassemble the cylinder:

MEL1074 – O-ring Seal Hook
Spanner Wrench

The lift and tilt cylinders internal components are similar, the differences are listed below:

- Tilt rod diameter is larger.
- Piston relief area is slightly different.
- No spacer in the tilt cylinder.

Hold the hydraulic cylinder over a drain pan and move the rod in and out slowly to remove the fluid from the cylinder.

Put the base end of the cylinder in a vise.

Use a spanner wrench to loosen the head [A] & [B].

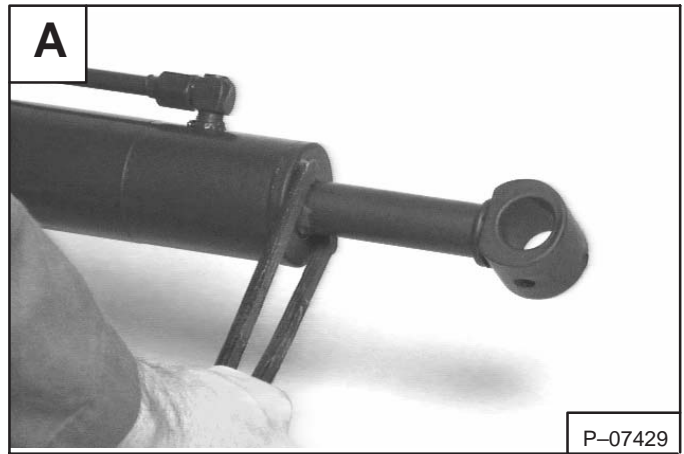

Lift Cylinder: Remove the head and the rod assembly from the cylinder [C]. Put the rod end in a vise.

Lift Cylinder: Remove the nut (Item 1) [C], piston (Item 2) [C], spacer (Item 3) [C] (if so equipped) and head (Item 4) [C].

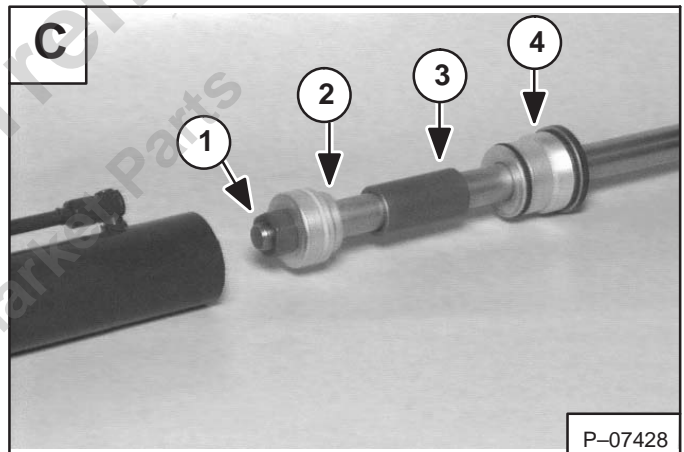

Tilt Cylinder: Remove the head and rod assembly from the cylinder [D]. Put the rod end in a vise.

Tilt Cylinder: Remove the nut (Item 1) [D], piston (Item 2) [D] and head (Item 3) [D].

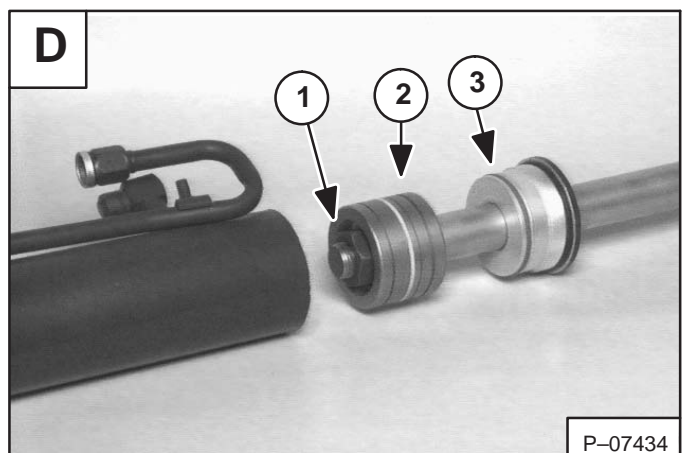

HYDRAULIC CYLINDERS (Cont'd)

Disassembly (Cont'd)

Standard Piston: Remove the seal (Item 1) [A], and O-ring (Item 2) [A] from the piston (Item 3) [A].

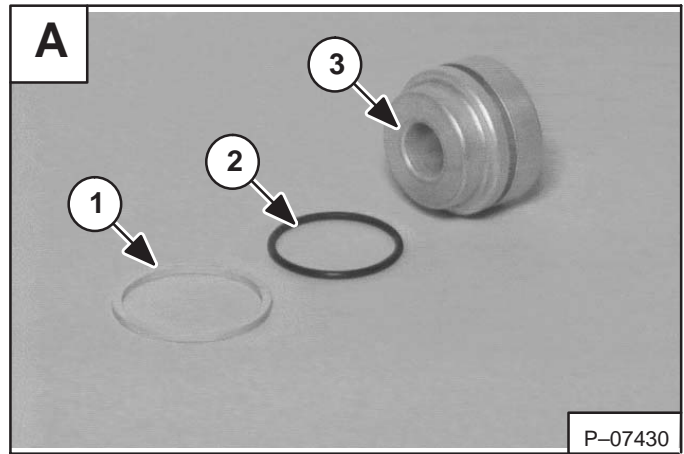

P-07430

Cushion Piston: Remove the seal (Item 1) [B], and O-ring (Item 2) [B] from the piston (Item 3) [B].

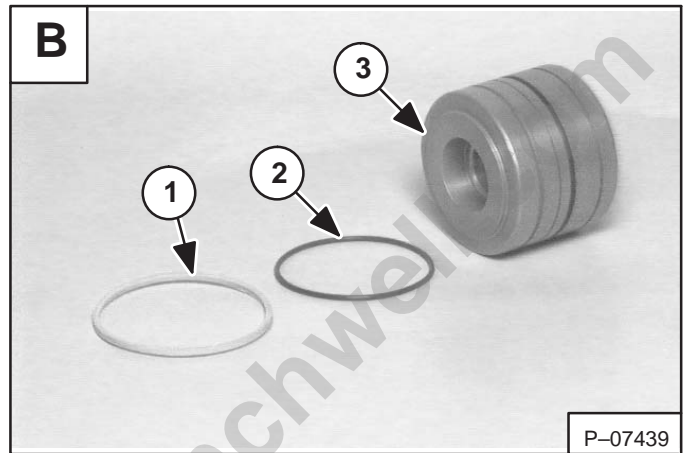

P-07439

Remove the thick O-ring (Item 1) [C], and the back-up washer (Item 2) [C] from the groove in the head. Remove the thin O-ring (Item 3) [C].

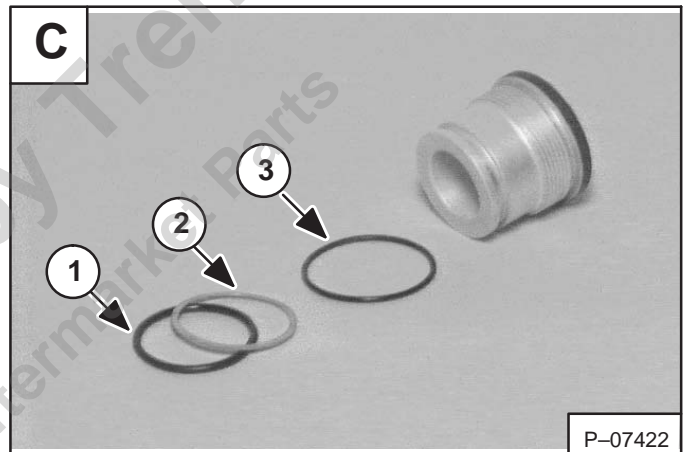

P-07422

Remove the wiper seat (Item 1) [D], and rod seal (Item 2) [D].

Remove the O-ring (Item 3) [D] from the rod seal.

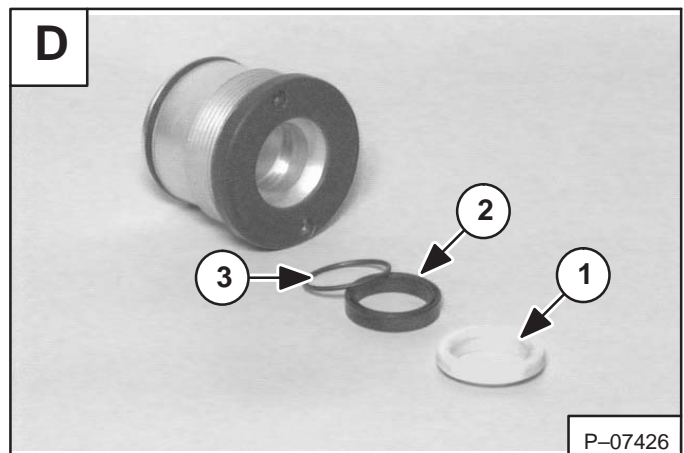

P-07426

HYDRAULIC CYLINDERS (Cont'd)**Assembly**

Use the following tools to assembly the cylinder:

MEL1396 – Seal Installation Tool
 MEL1033 – Rod Seal Installation Tool
 Piston Ring Compressor
 Spanner Wrench

Wash the cylinder parts in solvent and air dry them.

Inspect the cylinder parts for nicks, scratches or other damage. Replace any damaged parts.

Always install new O-rings and seals during assembly.

Lubricate all O-rings and seals with hydraulic oil during installation.

Install the new seal on the tool and slowly stretch it until it fits the piston **[A]**.

Allow the seal to stretch for 30 seconds before installing it on the piston.

Standard Piston: Install the seal (Item 1) **[B]** and O-ring (Item 2) **[B]** on the piston (Item 3) **[B]**.

Cushion Piston: Install the seal and O-ring on the piston (Item 1) **[C]**.

Use a ring compressor to compress the seal to the correct size. Leave the piston in the compressor for about three minutes.

Install the rod seal on the rod seal tool **[D]**.

NOTE: During installation the O-ring side of the seal must be toward the inside of the cylinder.

Rotate the handles to collapse the rod seal **[D]**.

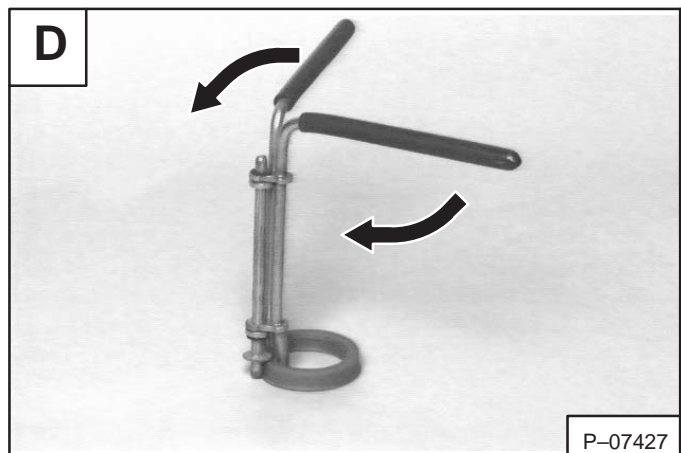
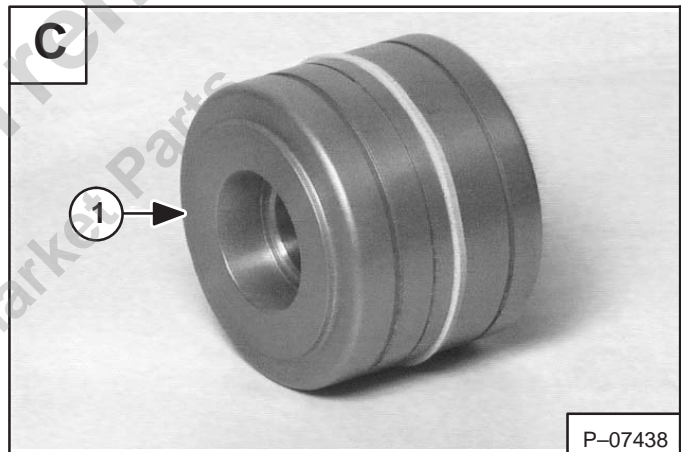
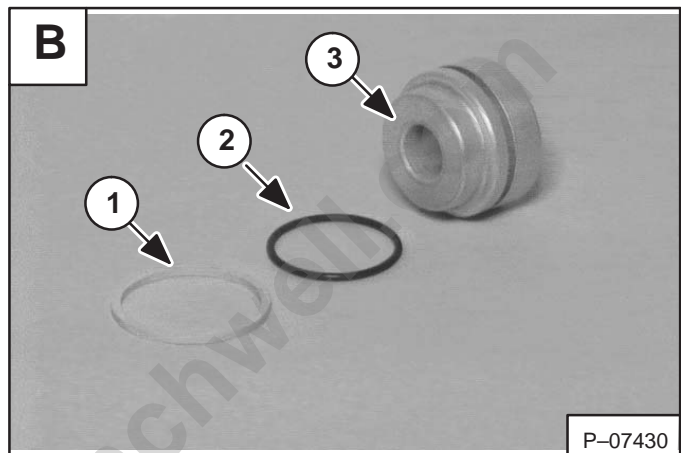
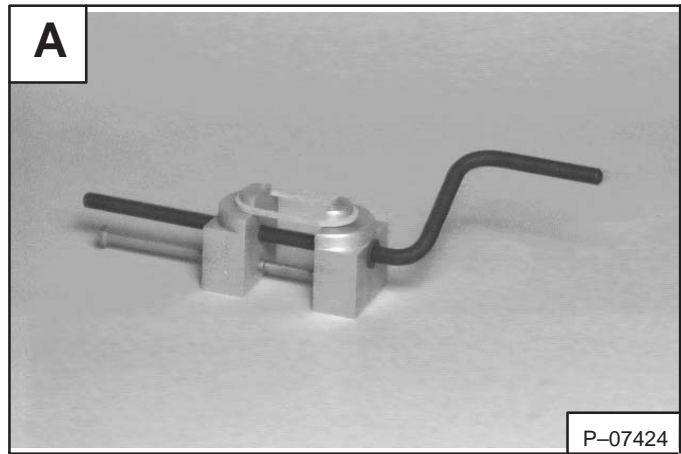

HYDRAULIC CYLINDERS (Cont'd)

Assembly (Cont'd)

Install the rod seal in the head **[A]**.

Install the wiper seal with the wiper toward the outside of the head.



Install the thin O-ring (Item 1) **[B]**.

Install the back-up washer (Item 2) **[B]** and thick O-ring (Item 3) **[B]** into the groove on the head.

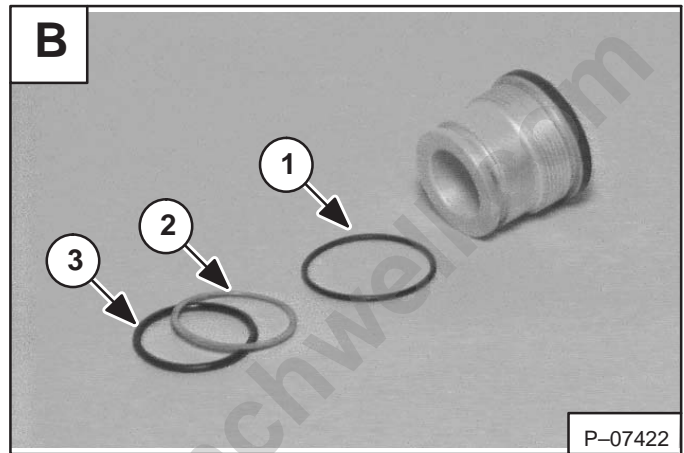

NOTE: Clean and dry the threads before install the nut. Install the new nut from the kit.

Tilt Cylinder: Install the head (Item 1) **[C]**, and the piston (Item 2) **[C]**. The small diameter of the piston goes into the cylinder tube first.

Tilt Cylinder: Grease the piston where the nut contacts the piston. Do not get grease on the threads.

Tilt Cylinder: Install the nut (Item 3) **[C]**.

Tilt Cylinder: Tighten the nut to 100 ft.-lbs. (136 Nm) torque.

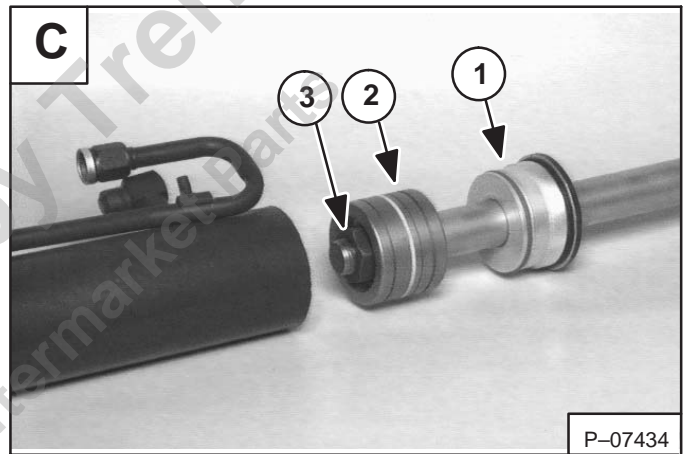

Tilt Cylinder: Mark the end of the shaft and nut **[D]**. Tighten the nut an additional 135 degrees or 2-1/4 flats **[D]**.

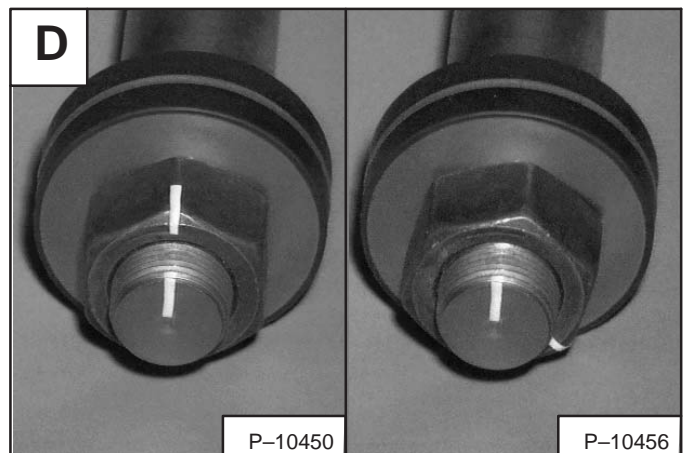

HYDRAULIC CYLINDERS (Cont'd)

Assembly (Cont'd)

NOTE: Clean and dry the threads before install the nut. Install the new nut from the kit.

Lift Cylinder: Install the head (Item 1) [A], and spacer (Item 2) [A].

Lift Cylinder: Install the piston (Item 3) [A], and the nut (Item 4) [A].

Lift Cylinder: Tighten the nut (Item 4) [A] to 600 ft.-lbs. (814 Nm) torque.

Put the base end of the hydraulic cylinder in a vise.

Tighten the head using a spanner wrench [B] & [C].

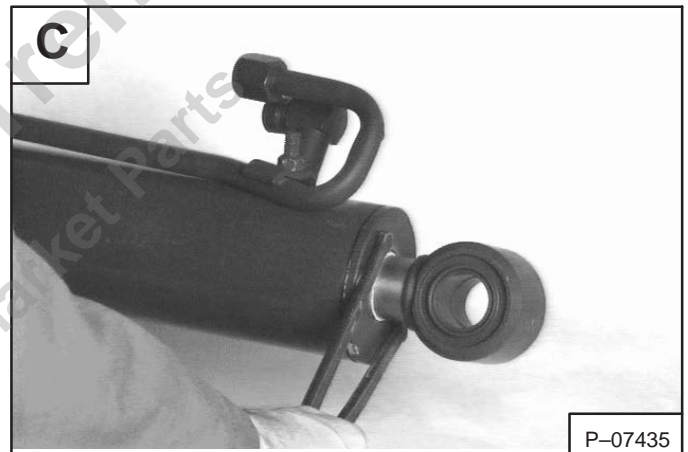
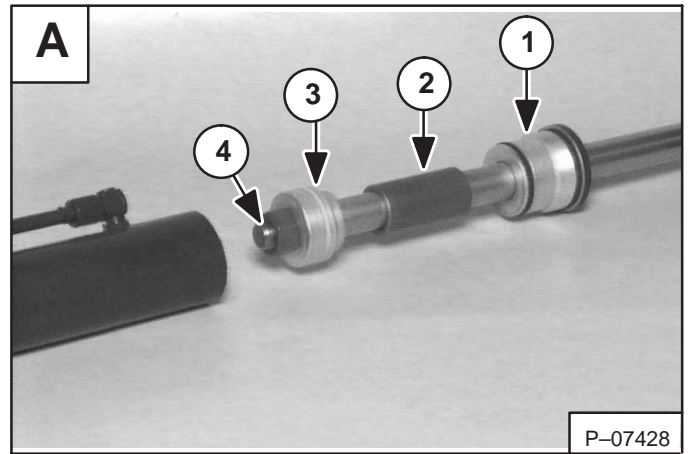

MAIN RELIEF VALVE

Checking The Main Relief Valve

The tools listed will be needed to do the following procedure:

- MEL10003 – Hydraulic Tester
- MEL10006 – Hydraulic Test Kit

Turn the key switch to the OFF position, as the engine stops running, turn the key switch all the way to the left to release the hydraulic pressure at the front auxiliary quick couplers.

Lift and block the loader. (See Page 1–1.)

Connect the IN port of the hydraulic tester to the female quick coupler on the loader [A].

Connect the OUT port of the hydraulic tester to the male quick coupler on the loader [A].

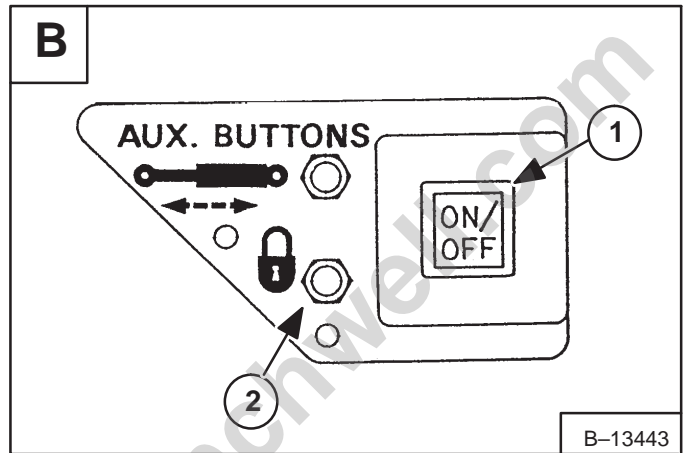
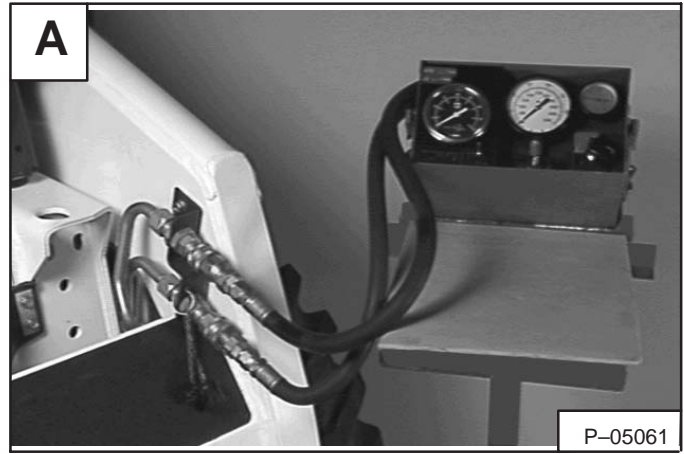

IMPORTANT

The hydraulic tester must be in the fully open position before you start the engine.

I-2024-0284

!

WARNING

Put jackstands under the front axles and rear corners of the frame before running the engine for service. Failure to use jackstands can allow the machine to fall or move and cause injury or death.

W-2017-0286

Start the engine and run at low engine idle RPM. Push the mode switch (Item 1) [B] two times (on the instrument panel) to engage the front auxiliary hydraulics, the light (Item 2) [B] will come ON.

Push the button (Item 1) [C] for fluid pressure to the quick couplers.

Watch the flow meter on the hydraulic tester to make sure the flow is correct. Increase the engine speed to full RPM.

There should be 18.0 GPM (68 L/min.) free flow. Turn the restrictor control, on the tester, until the main relief valve opens. The correct pressure for the main relief is 2700–2750 PSI (18617–18961 kPa).

If the relief pressure is not correct, stop the engine. Replace or adjust the main relief valve. (See Page 2–15.)

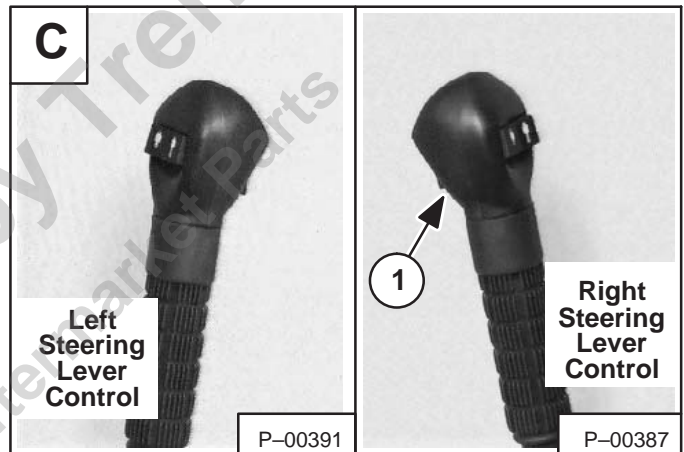

!

WARNING

When the engine is running during service, the steering levers must be in neutral and the parking brake engaged. Failure to do so can cause injury or death.

W-2006-0284

MAIN RELIEF VALVE (Cont'd)**Checking The Main Relief Valve Without Auxiliaries**

The tools listed will be needed to do the following procedure:

MEL10003 – Hydraulic Tester
MEL10006 – Hydraulic Test Kit

Stop the engine.

Lift and block the loader. (See Page 1–1.)

Disconnect the hydraulic hoses (Item 1) **[A]** at the tilt cylinder.

Connect the hydraulic tester to the tilt cylinder hoses **[B]**.

Have a second person in the operator seat, with seat bar in down position.

IMPORTANT

The hydraulic tester must be in the fully open position before you start the engine.

I-2024-0284

Start the engine and run at idle RPM.

Push the tilt pedal at the top (toe) or bottom (heel) until the hydraulic tester shows the correct fluid flow through the flow meter.

Increase the engine RPM to maximum.

There should be 18.0 GPM (68,1 L/min.) free flow.

Turn the restrictor control, at the tester, to increase the pressure until the main relief valve opens.

The correct pressure is 2700–2750 PSI (18617–18961 kPa).

If not, stop the engine.

Replace or adjust the main relief valve. (See Page 2–15.)

! WARNING

When an engine is running in an enclosed area, fresh air must be added to avoid concentration of exhaust fumes. If the engine is stationary, vent the exhaust outside. Exhaust fumes contain odorless, invisible gases which can kill without warning.

W-2050-1285

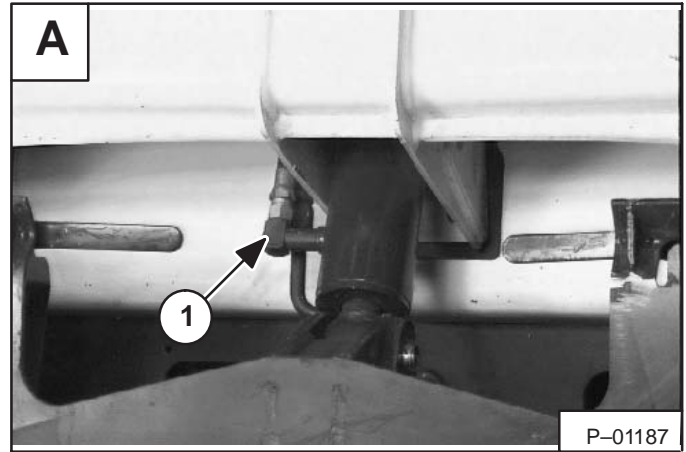

P-01187



P-01193

MAIN RELIEF VALVE (Cont'd)**Removal And Installation**

Raise the operator cab. (See Page 1-1.)

IMPORTANT

When making repairs on hydrostatic and hydraulic systems, clean the work area before disassembly and keep all parts clean. Always use caps and plugs on hoses, tubelines and ports to keep dirt out. Dirt can quickly damage the system.

I-2003-0284

The main relief valve (Item 1) [A] is located at the right rear of the control valve.

Clean the area around the control valve.

Loosen and remove the main relief valve [B].

Installation: Tighten the main relief valve to 35-40 ft.-lbs. (47-54 Nm) torque.

Remove the O-rings and back-up washers.

Clean the main relief valve in clean solvent. Use air pressure to dry the valve.

Install new O-rings and backup washers. Install the main relief valve and tighten [A]. Check the pressure again. (See Page 2-20.)

If the pressure is not correct, adjust the main relief valve. Remove the end cap (Item 1) [C].

Loosen the locking nut (Item 2) [C].

Turn the adjusting screw in or out until the pressure is correct.

Tighten the locking nut (Item 2) [C].

Reinstall the end cap (Item 1) [C].

NOTE: If the correct pressure can not be reached, replace the main relief valve. Check the pressure setting of the new relief valve.

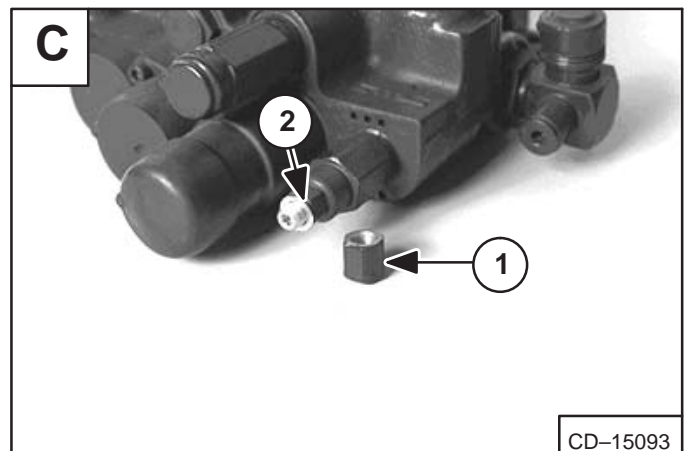
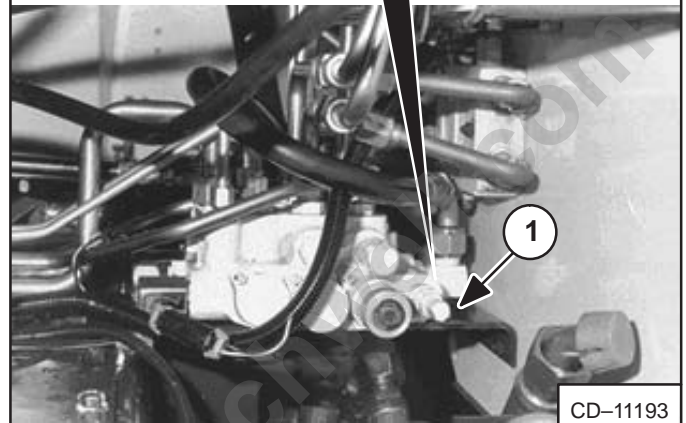
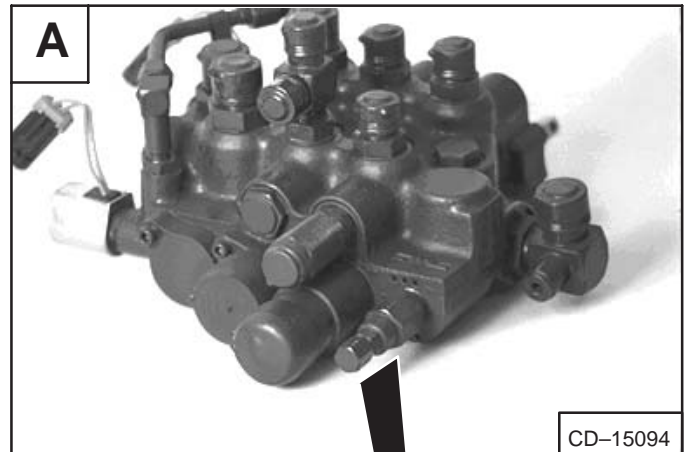

DUAL PRESSURE MAIN RELIEF VALVE (S/N 512811001 & Above) W/ Select Valve (JEM)

Checking The Low Setting

The tools listed will be needed to do the following procedure:

MEL10003 – Hydraulic Tester
MEL10006 – Hydraulic Test Kit

Turn the key switch to the OFF position. Before the engine stops running, turn the key switch all the way to the left to release the hydraulic pressure at the front auxiliary quick couplers.

Lift and block the loader. (See Page 1–1.)

Connect the IN port of the hydraulic tester to the female quick coupler on the loader [A].

Connect the OUT port of the hydraulic tester to the male quick coupler on the loader [A].

NOTE: Flow will be out from the female coupler on the loader.

IMPORTANT

The hydraulic tester must be in the fully open position before you start the engine.

I-2024-0284

Start the engine and run at low idle RPM. Push the mode switch (Item 1) [B] twice (on the instrument panel) to engage the front auxiliary hydraulics *detent*, both lights (Items 2 & 3) [B] will come ON.

NOTE: High horsepower switch should be in the OFF position.

Push the button (Item 1) [C] for fluid flow to the quick couplers.

Watch the flow meter on the hydraulic tester to make sure the flow is correct. Increase the engine speed to full RPM.

There should be approximately 18.0 GPM (68,1 L/min.) free flow. Turn the restrictor control, on the tester, until the main relief valve opens. The correct pressure for the main relief is 2700–2750 PSI (18617–18961 kPa).

Push the button (Item 1) [C] to disengage the *detent* flow to the front quick couplers.

If the relief pressure is not correct, stop the engine. Adjust or replace the main relief valve. (See Page 2–26.)

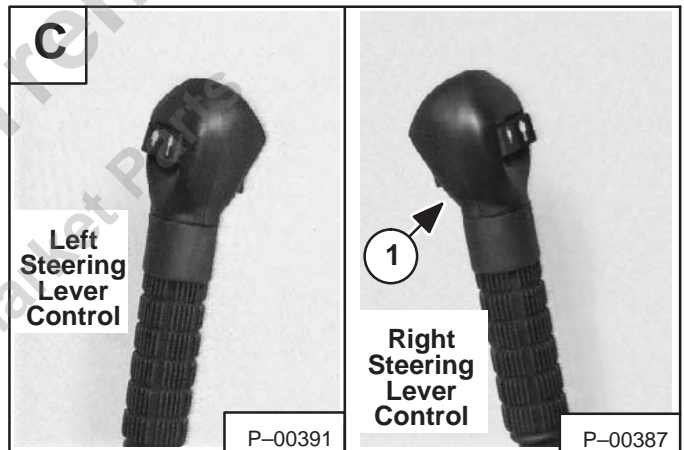
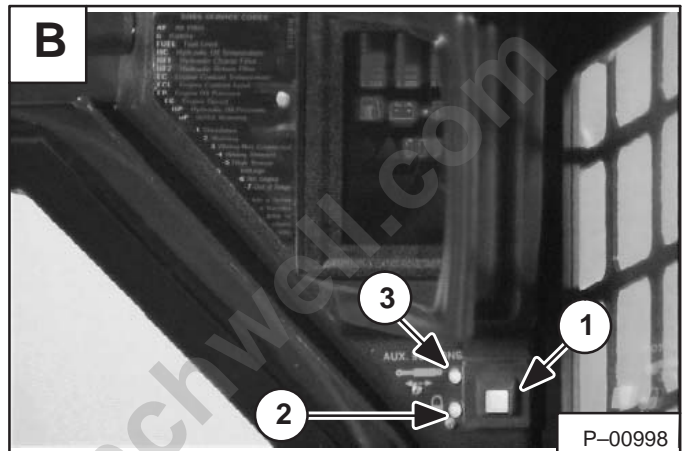
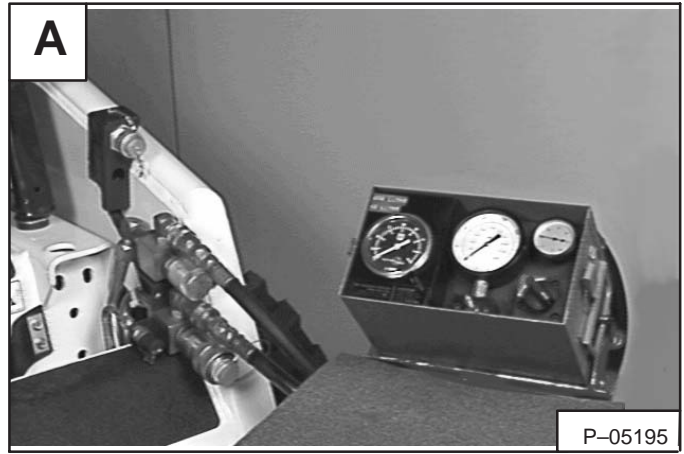

WARNING

Put jackstands under the front axles and rear corners of the frame before running the engine for service. Failure to use jackstands can allow the machine to fall or move and cause injury or death.

W-2017-0286

DUAL PRESSURE MAIN RELIEF VALVE (S/N 512811001 & Above) W/Select Valve (JEM) (Cont'd)**Checking The High Setting**

The tools listed will be needed to do the following procedure:

MEL10003 – Hydraulic Tester
MEL10006 – Hydraulic Test Kit

Turn the key switch to the OFF position. Before the engine stops running, turn the key switch all the way to the left to release the hydraulic pressure at the front auxiliary quick couplers.

Lift and block the loader. (See Page 1–1.).

Connect the hydraulic tester to the auxiliary quick coupler **[A]**.

The IN port on the tester connects to the female coupler on the loader.

The OUT port from the tester connects to the male coupler on the loader.

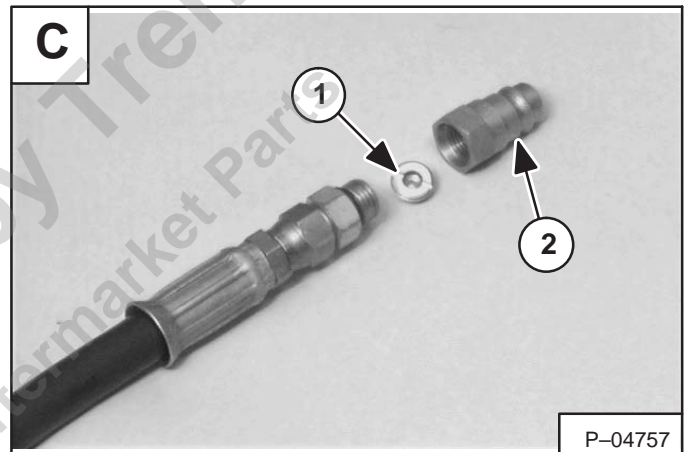
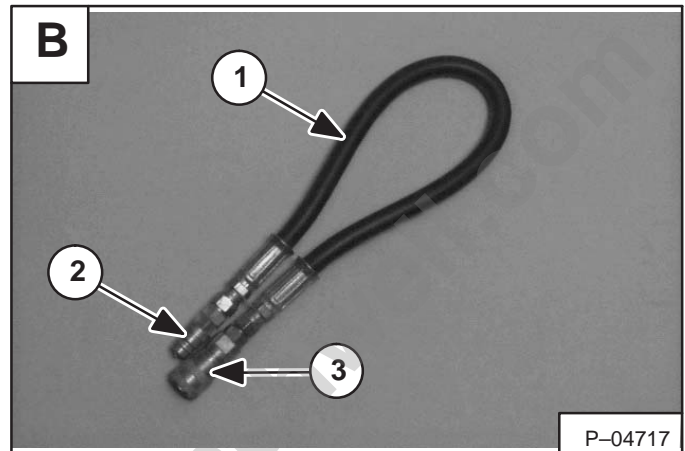
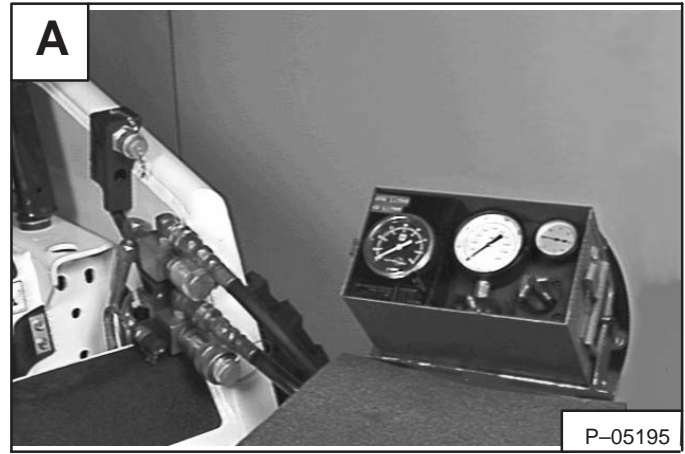
**IMPORTANT**

The hydraulic tester must be in the fully open position before you start the engine.

I-2024-0284

**WARNING**

Put jackstands under the front axles and rear corners of the frame before running the engine for service. Failure to use jackstands can allow the machine to fall or move and cause injury or death.

W-2017-0286

Obtain a 3/8 inch (9,5 mm) I.D. hose (Item 1) **[B]** with a 3000 PSI (20685 kPa) rating or greater.

The hose loop (Item 1) **[B]** should be approximately of 28 inches (711 mm) in length (including quick couplers).

A small male coupler (Item 2) **[B]** is needed for one end of the hose, and a small female coupler (Item 3) **[B]** is needed for the other end of the hose.

Use the correct fittings and O-rings to connect the couplers to the hose.

Drill orifice (Item 1) **[C]** size to 0.070 inch (1,8 mm). Install the threaded orifice (Item 1) **[C]** in the male coupler (Item 2) **[C]** and install the coupler on the fitting.

DUAL PRESSURE MAIN RELIEF VALVE (S/N 512811001 & Above) W/Select Valve (JEM) (Cont'd)

Checking The High Setting (Cont'd)

Install the hose (Item 1) [A] on the secondary auxiliary quick couplers as shown.

NOTE: The hose loop (Item 1) [A] (with .070 inch orifice), provides restriction and pilot pressure necessary to shift the dual stage main relief valve to the high pressure setting.



WARNING

When the engine is running during service, the steering levers must be in neutral and the parking brake engaged. Failure to do so can cause injury or death.

W-2006-0284

Start the engine and run at low idle RPM. Increase the engine speed to full RPM. Push the mode switch (Item 1) [B] twice (on the instrument panel) to engage the front auxiliary hydraulics *detent*, the lights (Items 2 & 3) [B] will come ON.

NOTE: The High Horsepower switch should be in the OFF position.

Push the button (Item 1) [C] to engage the *detent* position to the front auxiliary quick couplers.

Push and hold the button (Item 2) [C] for fluid flow through the secondary auxiliary couplers and hose loop.

Watch the flow meter on the hydraulic tester to be sure the flow is correct.

There should be approximately 18.0 GPM (68,1 L/min.) free flow. Turn the restrictor control on the tester, until the main relief valve opens. The correct pressure for the main relief is 3000 PSI (20685 kPa).

Release the button (Item 2) [C] and push the button (Item 1) [C] to disengage the *detent* position to the front auxiliary quick couplers.

If the relief pressure is not correct, stop the engine. Replace or adjust the main relief valve. (See Page 2-27.)

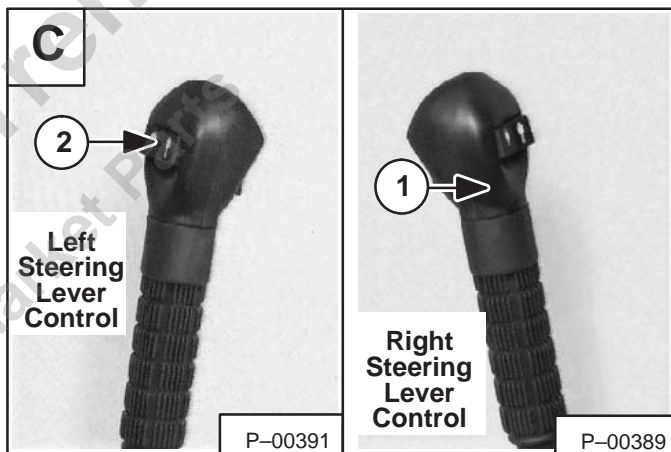
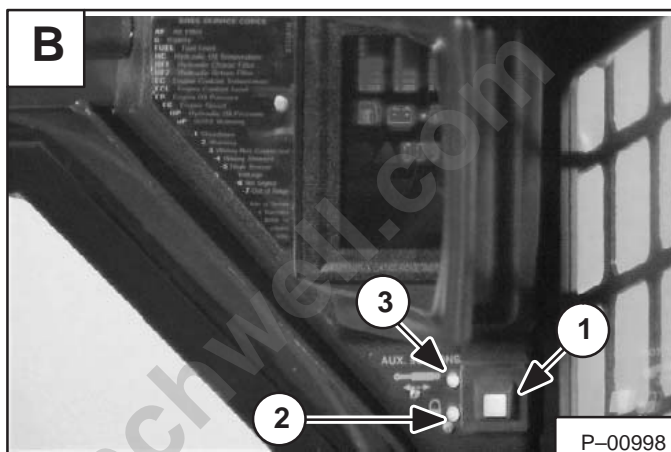
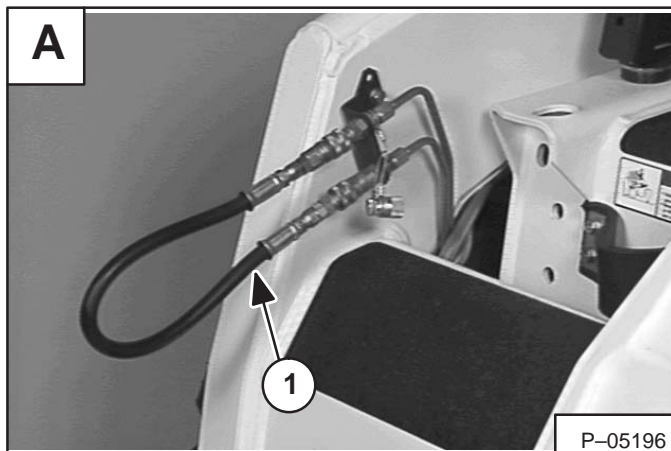

DUAL PRESSURE MAIN RELIEF VALVE (S/N 512811001 & Above) W/Select Valve (JEM) (Cont'd)

Adjusting The Low Setting

NOTE: Adjust the low pressure setting before adjusting the high pressure setting.

Correct pressure for the low setting is 2700–2750 PSI (18617–18961 kPa). (See Page 2–23 for the correct procedure to check the setting.)

To adjust the low pressure setting on the main relief valve, (Item 1) [A] disconnect the pilot hose (Item 2) [A] from the adapter fitting (Item 3) [A].

Remove the adapter fitting (Item 3) [A].

Remove the high pressure adjustment housing (Item 1) [B] from the main relief valve.

Use a 1/4" allen wrench (Item 1) [C] to turn the adjusting screw (Item 2) [C] in to increase pressure or out to decrease pressure.

One turn is equal to approximately 490 PSI (3379 kPa).

Reinstall the high pressure adjustment housing and adapter.

Reconnect the pilot hose.

Start the engine and increase the engine speed to full RPM. Check for the correct pressure setting.

Repeat the procedure until the pressure setting is approximately 2700–2750 PSI (18617–18961 kPa).

When the correct pressure setting is reached, the next step is to set the high pressure adjustment on the main relief valve. (See Page 2–24 for the correct procedure.)

Stop the engine.

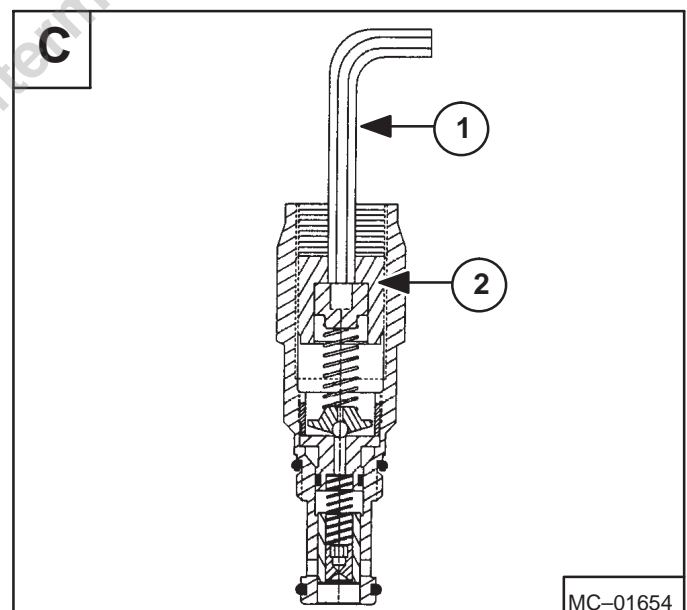
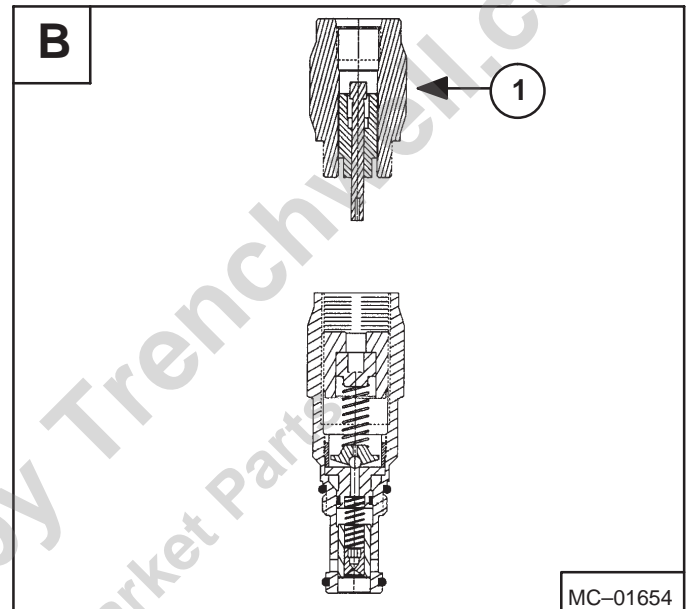
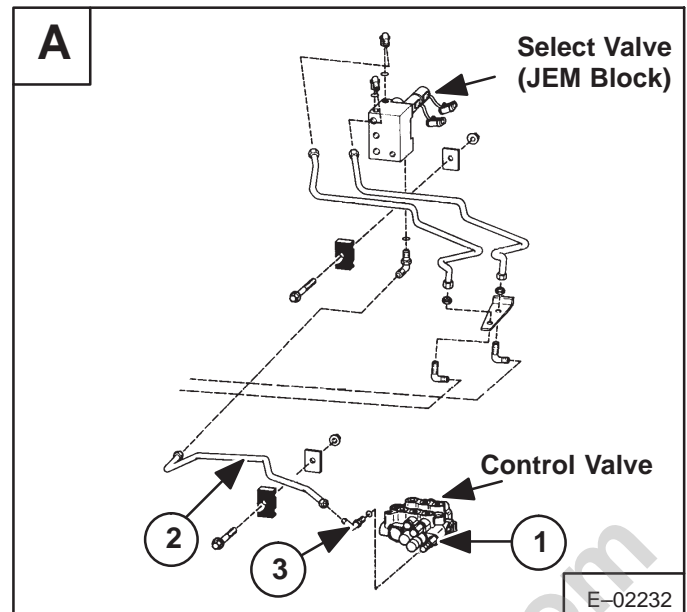

DUAL PRESSURE MAIN RELIEF VALVE (S/N 512811001 & Above) W/Select Valve (JEM) (Cont'd)

Adjusting The High Setting

NOTE: Adjust the low pressure setting before adjusting the high pressure setting.

Correct pressure for the high setting is 3000 PSI (20685 kPa). (See Page 2-24 for the correct procedure to check the setting.)

To adjust the high pressure setting on the main relief valve (Item 1) [A] disconnect the pilot hose (Item 2) [A] from the adapter fitting (Item 3) [A].

Remove the adapter fitting (Item 3) [A].

Use a 1/4" allen wrench (Item 1) [B] to press the push pin (Item 2) [B] in until it bottoms out.

Turn the adjusting guide (Item 3) [B] in to increase pressure or out to decrease pressure.

One turn is equal to approximately 390 PSI (2689 kPa).

Reinstall the adapter fitting and pilot hose.

Check for the high pressure setting.

Reconfirm the correct adjustment.

Repeat the adjustment procedure if necessary.

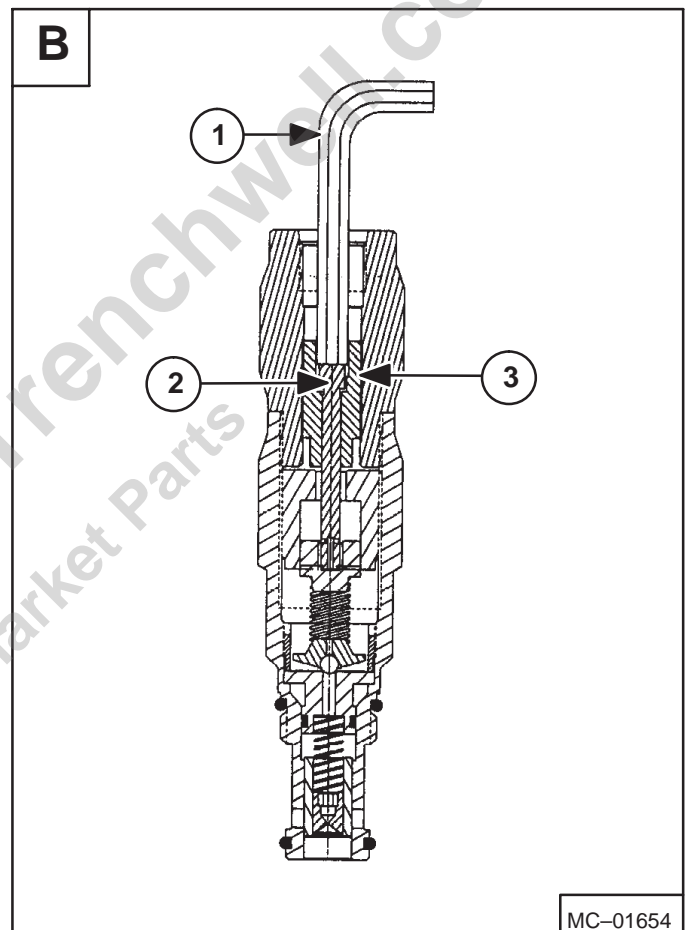
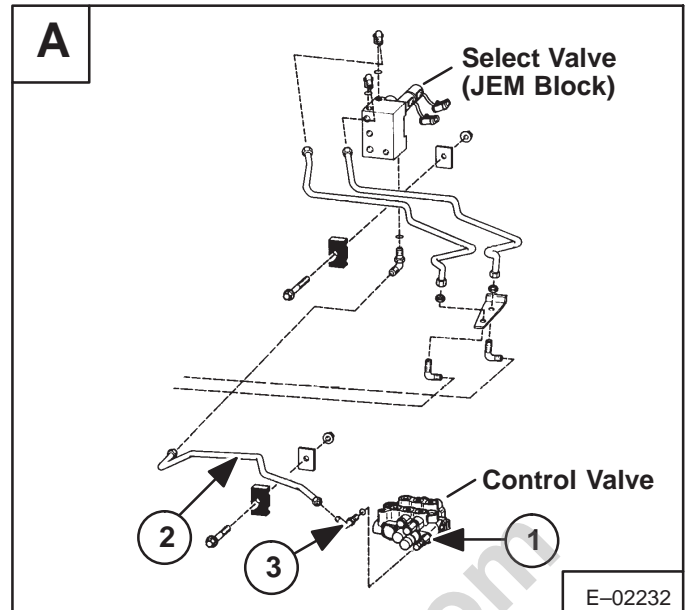

HYDRAULIC CONTROL VALVE

Removal And Installation (Cont'd)

⚠ WARNING

Never work on a machine with the lift arms up unless the lift arms are secured by an approved lift arm support device. Failure to use an approved lift arm support device can allow the lift arms or attachment to fall and cause injury or death.

W-2059-0598

⚠ DANGER

AVOID DEATH

- Disconnecting or loosening any hydraulic tubeline, hose, fitting, component or a part failure can cause lift arms to drop.
- Keep out of this area when lift arms are raised unless supported by an approved lift arm support. Replace if damaged.

53145

SW 98 6717343

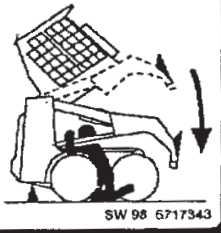

Stop the engine. Move the hydraulic controls to release the hydraulic pressure. Raise the seat bar.

Lift and block the loader. (See Page 1-1.)

Raise the operator cab. (See Page 1-1.)

Clean the area around the control valve.

Remove both cotter pins from the clevis pins connecting the linkages to the valve spools [A].

Remove the clevis pins (Item 1) [A] from the linkages.

Remove the two tubelines (Item 1) [B] from the auxiliary section of the control valve.

Disconnect the front auxiliary control valve return hose (Item 2) [B].

Remove the two tubelines (Item 1) [C] from the tilt section on the control valve.

Remove the three tubelines (Item 1) [D] from the lift section on the control valve.

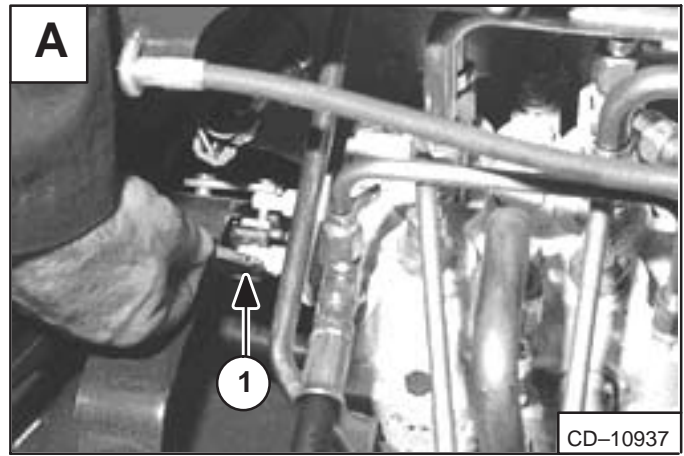

CD-10937

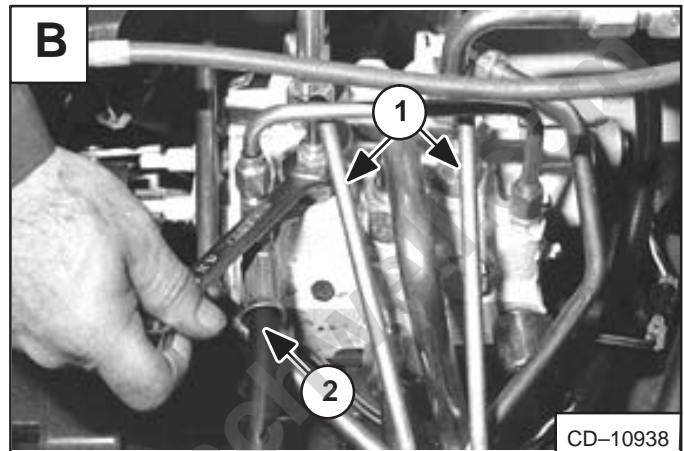

CD-10938

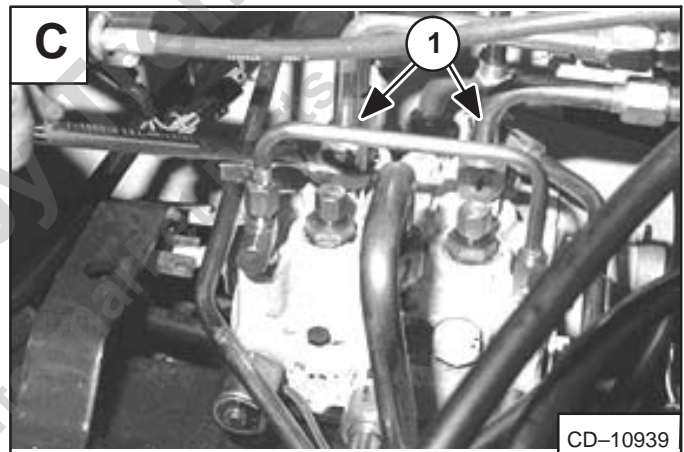

CD-10939

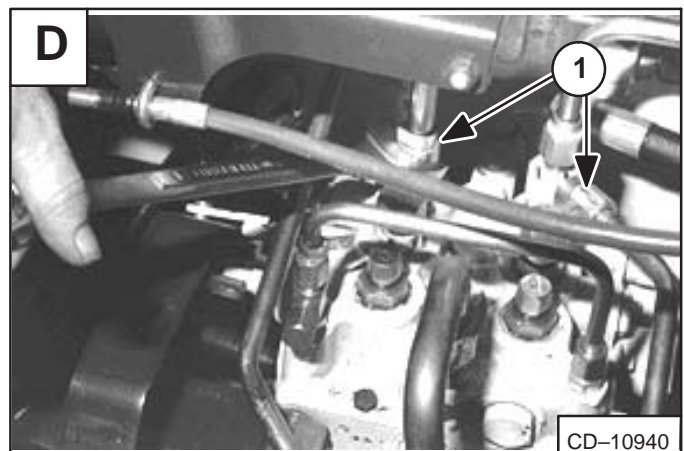

CD-10940

HYDRAULIC CONTROL VALVE (Cont'd)**Removal And Installation (Cont'd)**

Remove the control valve outlet tubeline (Item 1) [A] from the control valve.

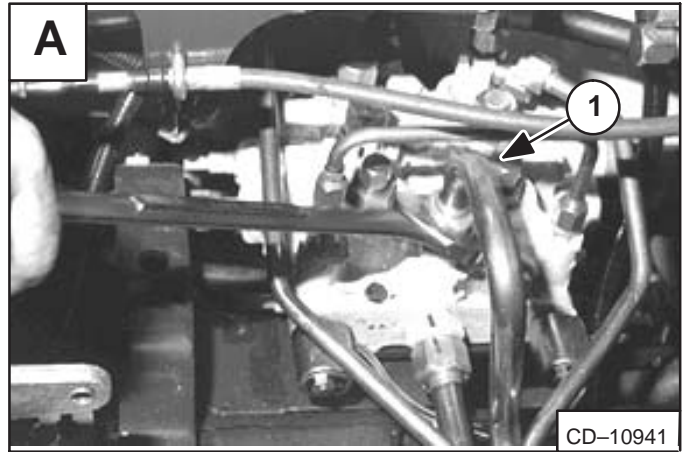

Remove the power beyond tubeline which goes to the auxiliary control valve inlet [B].

Disconnect the control valve inlet hose (Item 1) [B] which comes from the outlet of the hydraulic pump.

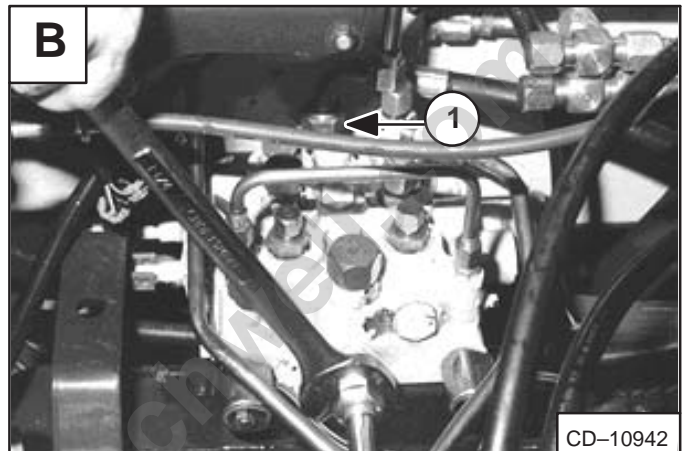

Disconnect the two connectors from the solenoids on the auxiliary section of the control valve [C].

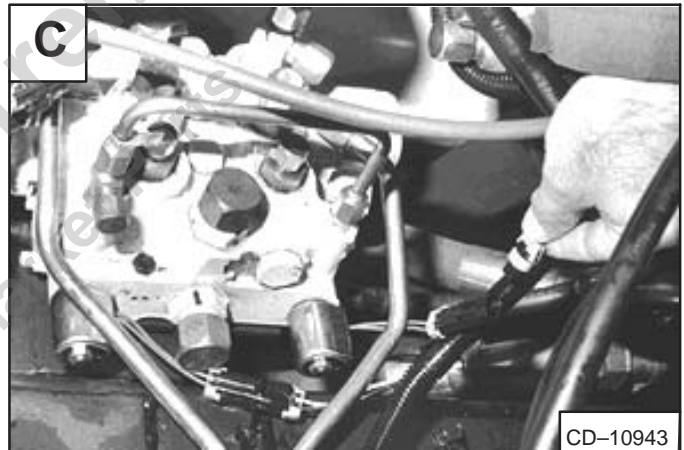

Remove the two mounting bolts and remove the control valve [D].

Installation: Tighten the mounting bolts to 25 ft.-lbs. (34 Nm) torque.

SEE THE COMPONENT REPAIR MANUAL FOR THE HYDRAULIC CONTROL VALVE FOR THE DISASSEMBLY AND ASSEMBLY PROCEDURE.

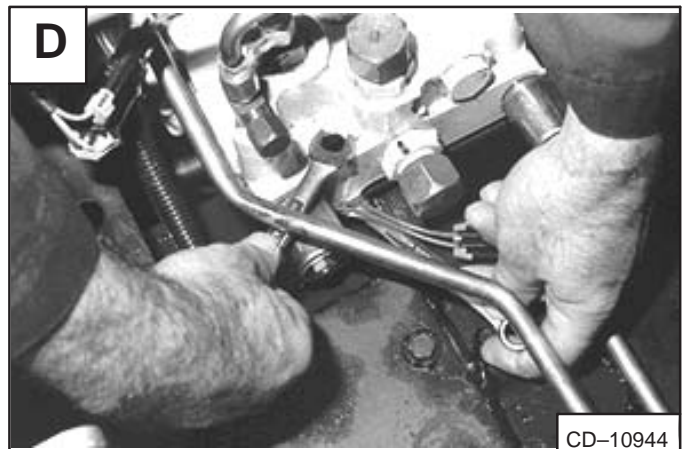

SELECT VALVE (S/N 512811001 & Above) W/Select Valve (JEM)**Checking The Relief Valve**

The tools listed will be needed to do the following procedure:

MEL10003 – Hydraulic Tester
MEL10006 – Hydraulic Test Kit

Lift and block the loader. (See Page 1–1.)

Connect the IN port of the hydraulic tester to the female quick couplers (Item 1) **[A]** on the loader.

Connect the OUT port of the hydraulic tester to the male quick coupler (Item 2) **[A]** on the loader.

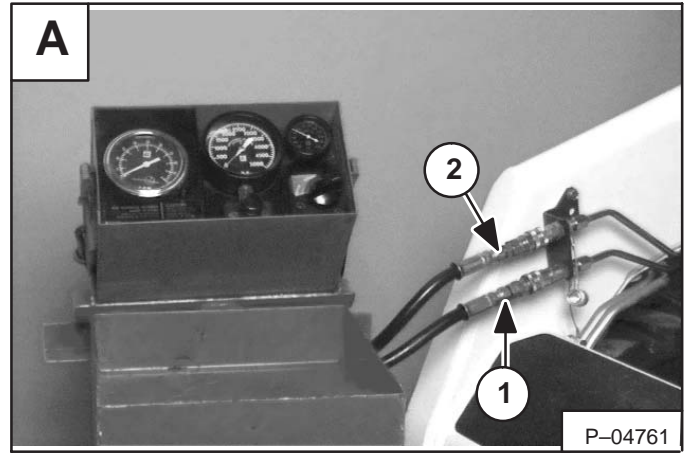

IMPORTANT

The hydraulic tester must be in the fully open position before you start the engine.

I-2024-0284

! WARNING

Put jackstands under the front axles and rear corners of the frame before running the engine for service. Failure to use jackstands can allow the machine to fall or move and cause injury or death.

W-2017-0286

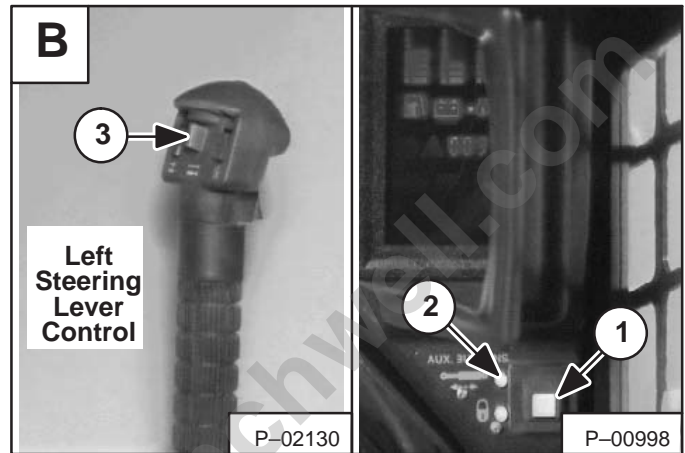

Start the engine and run at low idle RPM. Push the mode switch (Item 1) **[B]** once (on the instrument panel) to engage the front auxiliary hydraulics momentary, the light (Item 2) **[B]** will come ON.

Push the rocker switch (Item 3) **[B]** for fluid pressure to the secondary quick couplers.

Watch the flow meter on the hydraulic tester to make sure the flow is correct. Increase the engine speed to full RPM.

The free flow should be approximately 8.0 GPM (30,3 L/min.). Turn the restrictor control, on the tester, until the main relief valve opens. The correct pressure for the main relief is approximately 3000 PSI (20685 kPa).

Release the rocker switch (Item 3) **[B]** to disengage the flow to the secondary quick couplers.

SELECT VALVE (S/N 512811001 & Above) W/Select Valve (JEM) (Cont'd)

Checking The Relief Valve (Cont'd)

If the relief pressure is not correct, stop the engine. Adjust the relief valve in the select valve (Item 1) [A]. The select valve is located at the left side under the control panel.

Remove the cap from the relief valve (Item 1) [B]. Loosen the locking nut (Item 2) [B]. Turn the adjusting screw (Item 3) [B] in or out until the correct pressure is reached. If the correct pressure is not reached remove the relief valve and inspect the O-rings and back-up rings (Item 4) [B]. Replace the relief valve if required.

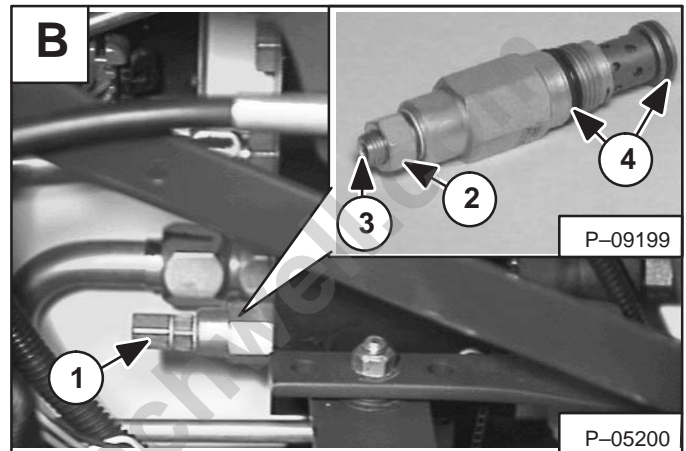
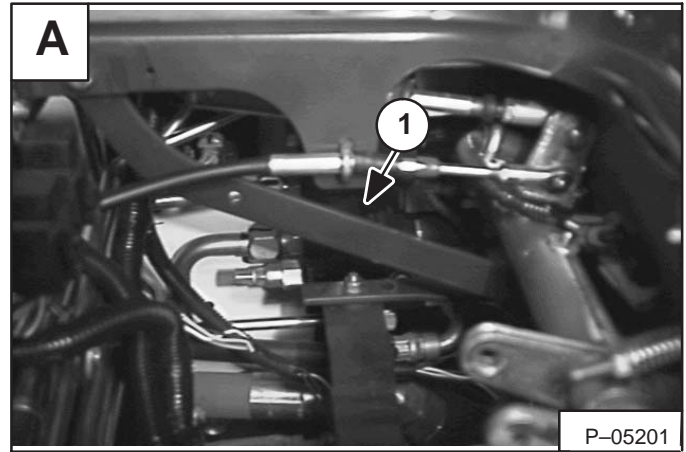

Provided for Free by Trendright
Shop Aftermarket Parts

SELECT VALVE (S/N 512811001 & Above) W/Select Valve (JEM) (Cont'd)

Removal And Installation

Raise the operator cab. (See Page 1-1.)

Remove the bolt (Item 1) [A].

Disconnect the controls harness at the left side steering lever connectors (Item 2) [A].

If so equipped disconnect the attachment harness from the controls harness and the left side steering lever connectors. Put the relay assembly (Item 3) [A] and attachment harness aside.

Remove the front mount nut and steering panel brace (Item 4) [A].

Disconnect the controls harness from the select valve connectors (Item 1) [B].

Remove the rear bolt (Item 2) [B] on the left side pedal link (Item 3) [B].

Remove the link front bolt and push the link (Item 3) [B] forward.

Disconnect and remove the tubeline (Item 1) [C].

Disconnect and lower the tubeline (Item 2) [C].

Disconnect the tubeline (Item 3) [C].

Disconnect the hose (Item 4) [C].

Disconnect the tubelines (Item 1) [D] at the select valve.

Install caps and plugs on open connections.

Remove the select valve.

Installation: Connect controls harness to select valve solenoids. Refer to the Electrical Wiring Diagram for the correct controls harness wire colors.

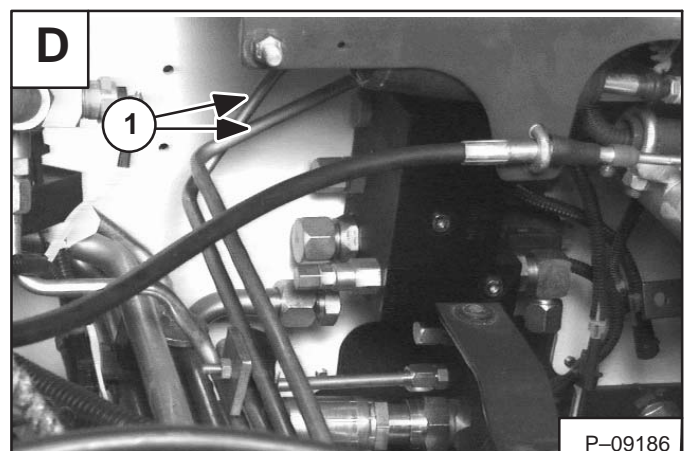
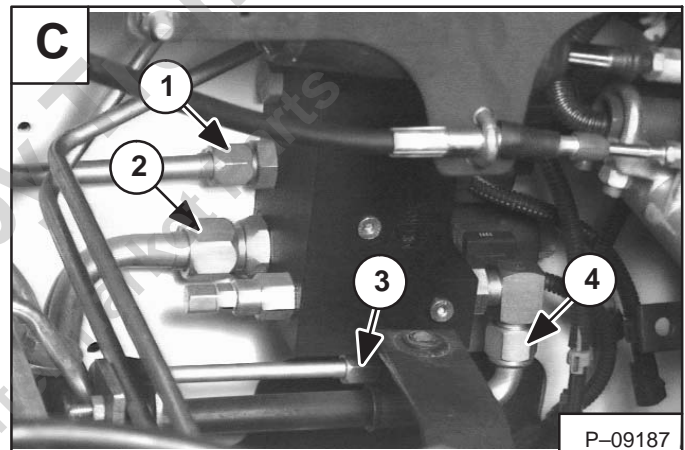
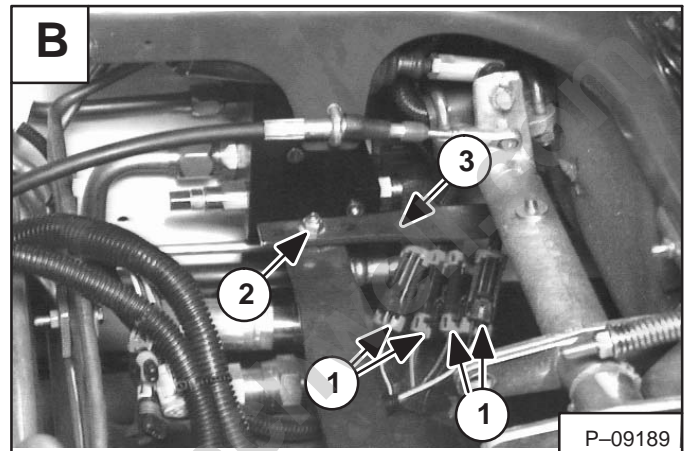
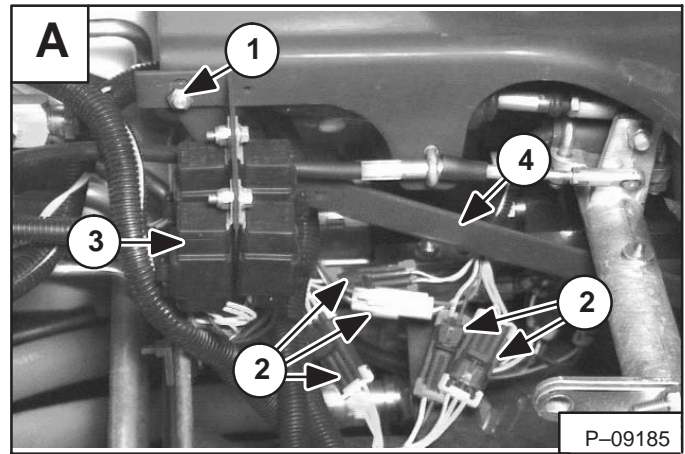

SELECT VALVE (S/N 512811001 & Above) W/Select Valve (JEM) (Cont'd)

Removal And Installation (Cont'd)

Remove the mounting bolts (Item 1) [A] located on the outside left frame.

Remove the select valve.

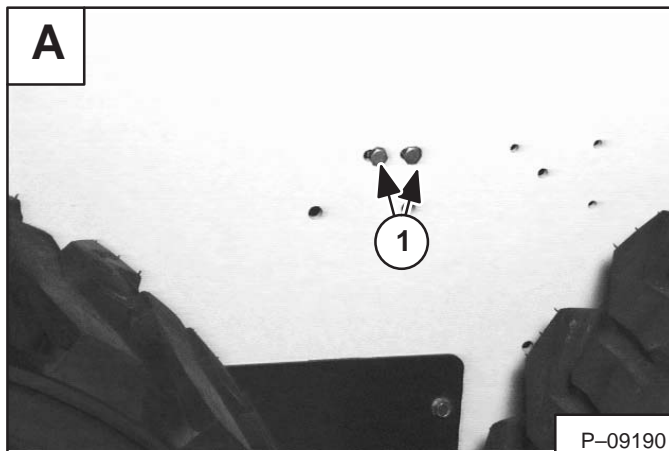

Disassembly And Assembly

Clean the select valve to remove dirt before disassembly.

IMPORTANT

When repairing hydrostatic and hydraulic systems, clean the work area before disassembly and keep all parts clean. Always use caps and plugs on hoses, tubelines and ports to keep dirt out. Dirt can quickly damage the system.

I-2003-0888

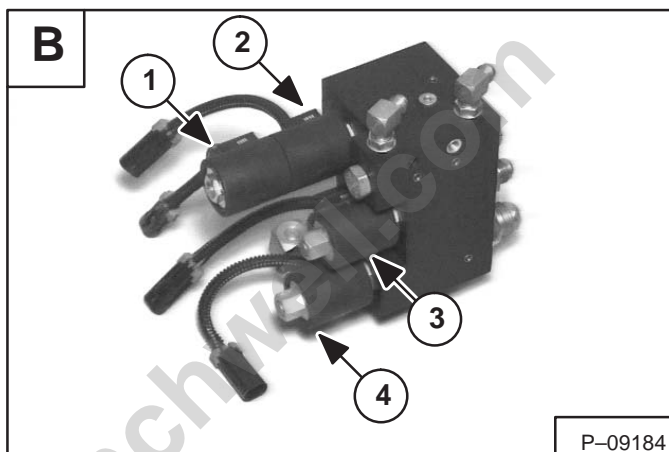

Remove the solenoid valve coils in Fig. [B].

NOTE: The controls wiring harness colors are listed below for identification during select valve assembly installation.

- Second aux. male coupler (Item 1) [B] Yellow/Brown
- Second aux. female coupler (Item 2) [B] Yellow/Lt. Green
- High Flow (Item 3) [B] Lt. Blue/Red
- Second aux. diverter (Item 4) [B] Yellow

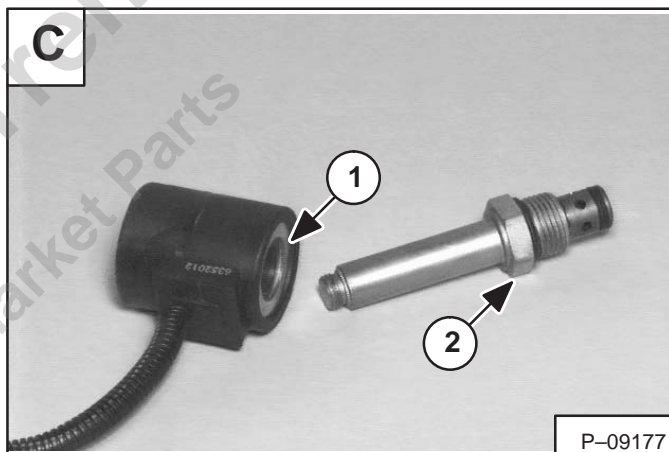

Assembly: The coils largest opening (Item 1) [C] must position on the valve shoulder (Item 2) [C]. Install the washer (Item 1) [D] between the double coils. Install the coils and tighten the nuts (Item 2) [D] to 5 ft.-lbs. (6,7 Nm) torque.

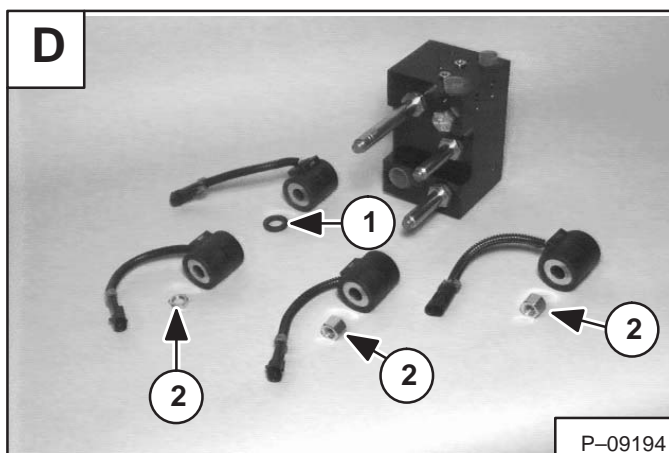

SELECT VALVE (S/N 512811001 & Above) W/Select Valve (JEM) (Cont'd)**Disassembly And Assembly (Cont'd)**

Remove the 4-way solenoid valve (Item 1) [A].

Remove the check valve (Item 2) [A].

Remove the pilot piston (Item 3) [A] located between the check valves (Item 2) [A] & [B].

Remove the 2-way solenoid valves (Item 4) [A].

Inspect the solenoid valves for contamination or damage. Wash all parts in clean solvent. Use air pressure to dry them. Install new O-rings and back-up washers.

Remove the fitting (Item 1) [B]. Remove the check valve (Item 2) [B].

Remove the relief valve (Item 3) [B].

Inspect the relief valve, check valves, pilot piston, and fitting for contamination or damage. Wash all parts in clean solvent. Use air pressure to dry them. Install new O-rings and back-up washers.

The fitting (Item 1) [B] and fig. [C] has a poppet valve. The poppet valve allows flow out of the select valve only. Inspect the poppet (Item 1) [C] for smooth opening and closing.

Assembly: Put oil on O-rings and back-up washers. Install and tighten the solenoid valves (Items 1 & 4) [A] to 25 ft.-lbs. (33,9 Nm) torque. Install the pilot piston (Item 3) [A] in the port between the check valves (Item 2) [A] & [B]. Install the check valves and tighten to 20 ft.-lbs. (27,1 Nm) torque.

Install the fitting (Item 1) [B] and tighten to 20 ft.-lbs. (27 Nm) torque. Install the relief valve (Item 3) [B] and tighten to 25 ft.-lbs. (33,9 Nm) torque.

Solenoid Testing

Use a test meter to measure coil resistance [D]. Coil wires do not have polarity. Correct resistance for the coils is 5–8 ohms.

Replace the test meter with 12 volt power. You can see and hear the spool shift.

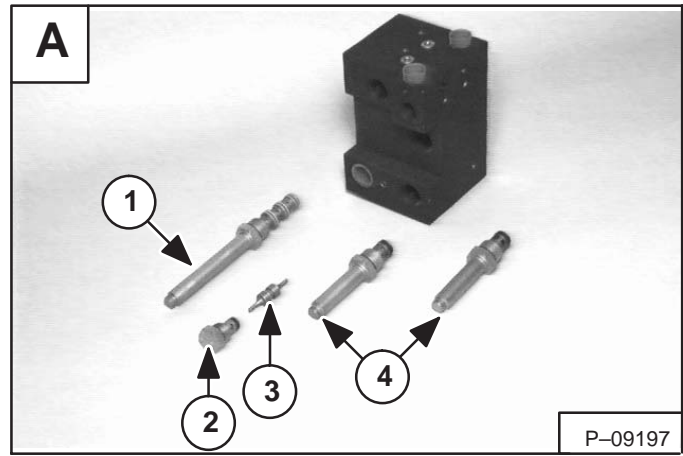

P-09197

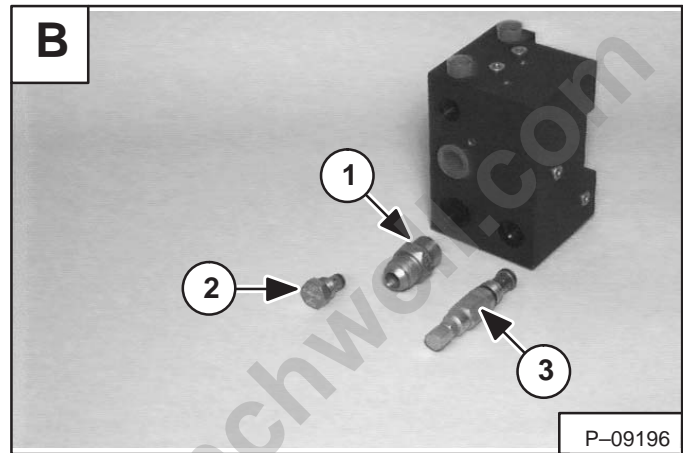

P-09196

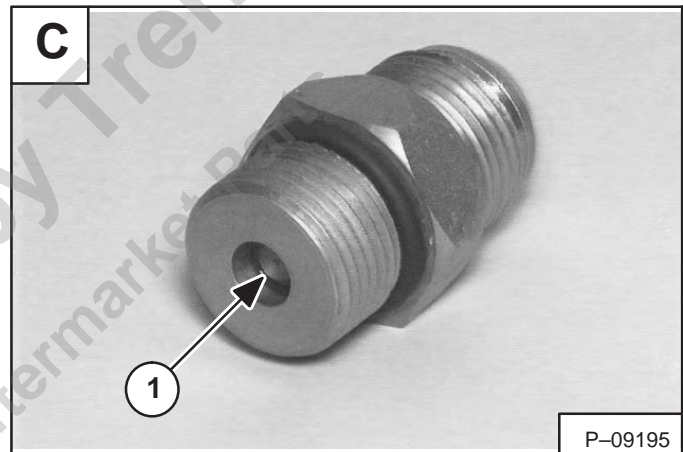

P-09195



P-09175

HYDRAULIC FILTER HOUSING

Removal And Installation

 **WARNING**

Never work on a machine with the lift arms up unless the lift arms are secured by an approved lift arm support device. Failure to use an approved lift arm support device can allow the lift arms or attachment to fall and cause injury or death.

W-2059-0598

 **DANGER**
AVOID DEATH

- Disconnecting or loosening any hydraulic tubeline, hose, fitting, component or a part failure can cause lift arms to drop.
- Keep out of this area when lift arms are raised unless supported by an approved lift arm support. Replace if damaged. 531 45

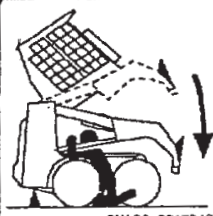

SW 98 6717343

Disconnect the tubelines from the inlet of the hydraulic filter [A].

Disconnect the hose (Item 1) [B] from the outlet of the filter.

Remove the two mounting bolts and remove the hydraulic filter and housing [C].

Installation: Tighten the mounting bolts to 25 ft.-lbs. (34 Nm) torque.

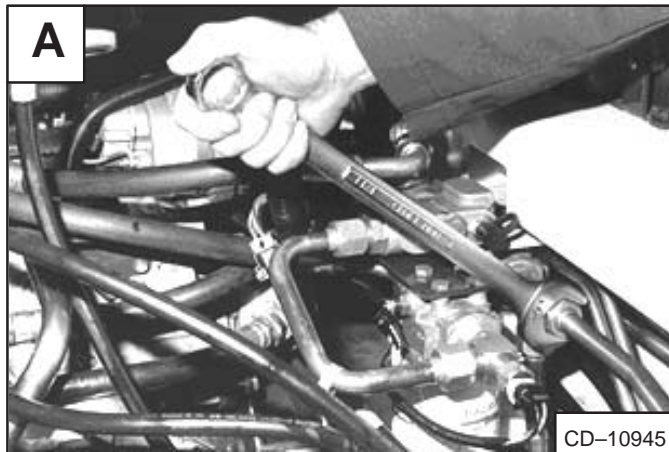

CD-10945

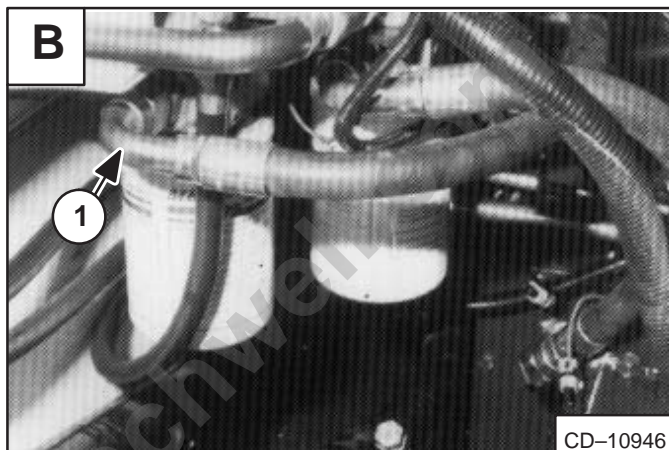

CD-10946

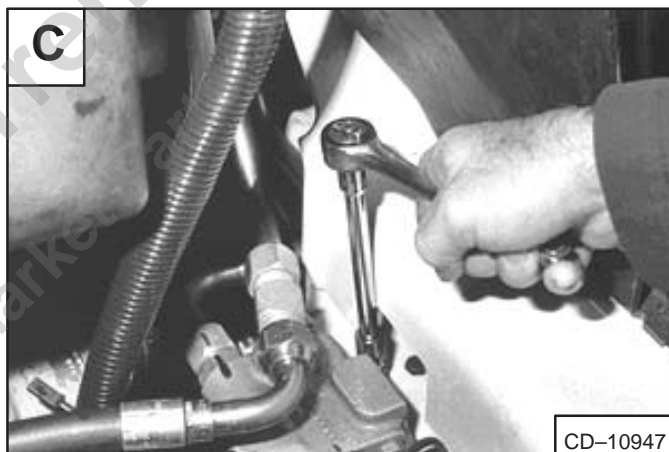

CD-10947

HYDRAULIC PUMP

Checking The Output Of The Pump

The tools listed will be needed to do the following procedure:

MEL10003 – Hydraulic Tester
MEL10006 – Hydraulic Test Kit

NOTE: Make sure all the air is removed from the hydraulic system before beginning the test. Air in the system can give an inaccurate test.

***Relief pressure must be per specification before the test is done.**

Lift and block the loader. (See Page 1–1.)

Raise the operator cab. (See Page 1–1.)

Connect the remote start switch. (See Page 1–1.)

Disconnect the OUTLET hose from the pump [A].

Connect the INLET hose from the tester to the OUTLET of the pump. Connect the OUTLET hose from the tester to the hose which was disconnected from the pump [B].

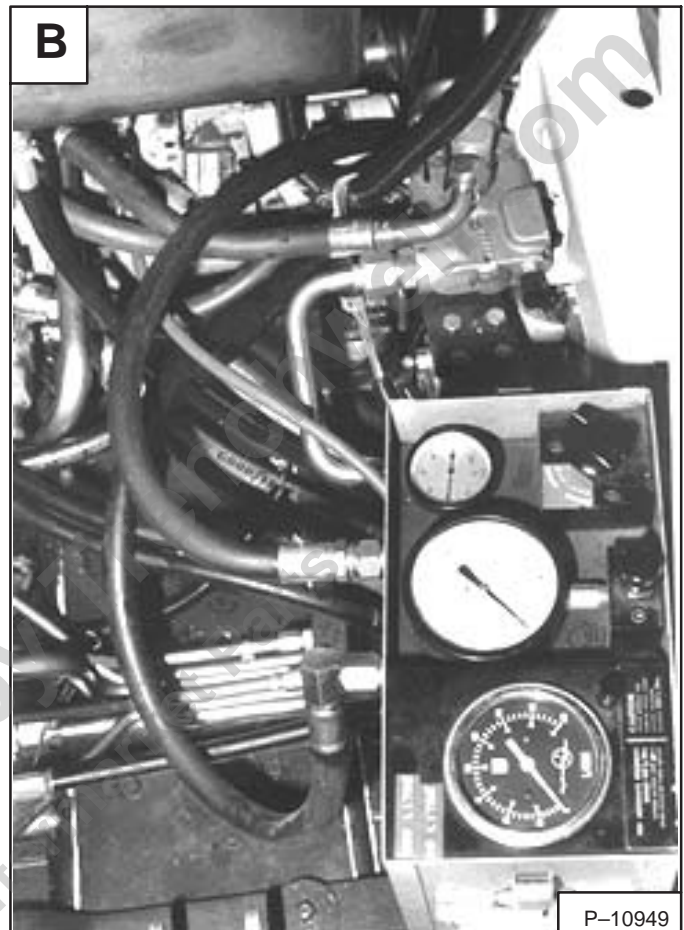
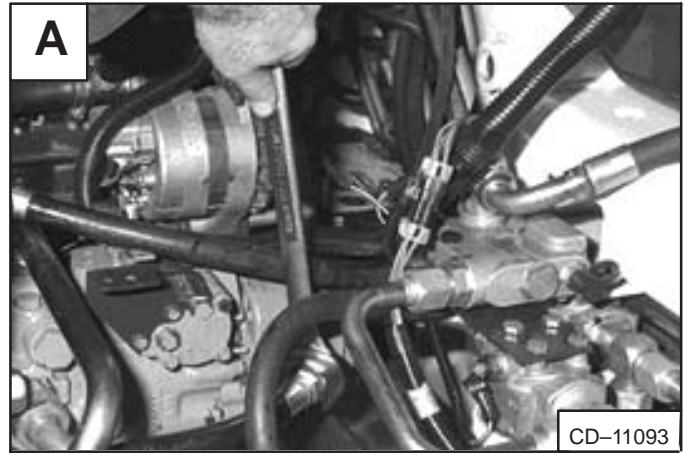

WARNING

Put jackstands under the front axles and rear corners of the frame before running the engine for service. Failure to use jackstands can allow the machine to fall or move and cause injury or death.

W-2017-0286

Start the engine and run at low idle RPM. Make sure the tester is connected correctly. If no flow is indicated on the tester, the hoses are connected wrong. With the hoses connected correctly, increase the engine speed to full RPM.

Warm the fluid to 140°F. (60°C.) by turning the restrictor control on the tester to about 1000 PSI (6895 kPa). DO NOT exceed system relief pressure. Open the restrictor control and record the free flow (GPM) at full RPM.

Push the mode switch (on the remote start switch) to engage the front auxiliary hydraulics, the light will come ON. Push the button (on the right steering lever) for fluid pressure to the quick coupler (fluid pressure will go over main relief). Record the highest pressure (PSI) and flow (GPM). The high pressure flow must be at least 80% of free flow.

$$\% = \frac{\text{HIGH PRESSURE FLOW (GPM)}}{\text{FREE FLOW (GPM)}} \times 100$$

A low percentage may indicate a pump problem.

HYDRAULIC PUMP (Cont'd)**Removal And Installation**

NOTE: The hydraulic pump is shown being removed with the hydrostatic pump/engine assembly out of the loader for photo clarity. It can be removed in the loader.

IMPORTANT

When making repairs on hydrostatic and hydraulic systems, clean the work area before disassembly and keep all parts clean. Always use caps and plugs on hoses, tubelines and ports to keep dirt out. Dirt can quickly damage the system.

I-2003-0284

! WARNING

Never work on a machine with the lift arms up unless the lift arms are secured by an approved lift arm support device. Failure to use an approved lift arm support device can allow the lift arms or attachment to fall and cause injury or death.

W-2059-0598

Raise the operator cab. (See Page 1-1.)

Drain the hydraulic reservoir. (See Page 1-1.)

Disconnect the hose (Item 1) [A] from the pump outlet. Install a cap on the fitting.

Disconnect the tubeline from the inlet of the pump [A].

Remove the pump mounting bolts [B].

Remove the hydraulic pump [C].

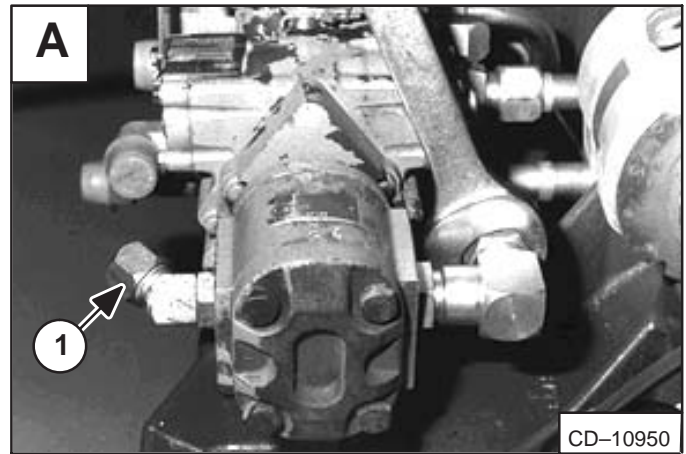

CD-10950



CD-10951

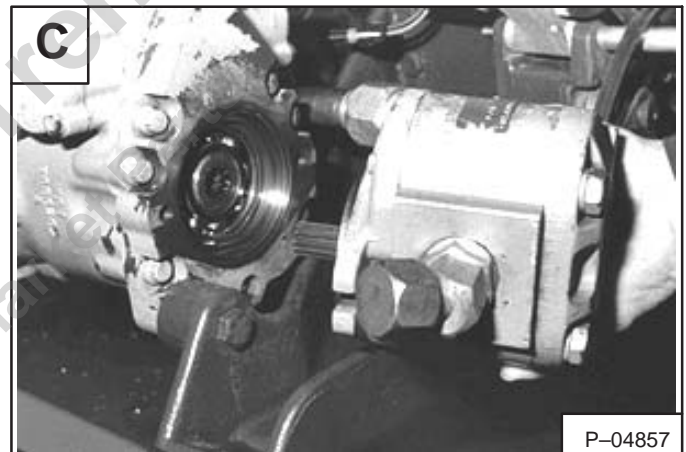

P-04857

! WARNING

Always clean up spilled fuel or oil. Keep heat, flames, sparks or lighted tobacco away from fuel and oil. Failure to use care around combustibles can cause explosion or fire which can result in injury or death.

W-2103-1285

HYDRAULIC FLUID RESERVOIR

Removal And Installation

Raise the operator cab. (See Page 1-1.)

Disconnect the motor case drain hose from the case drain filter (Item 1) **[A]**.

Cap and plug the filter and hose. Remove the case drain filter (Item 1) **[A]** (if so equipped) and drain the fluid into a container.

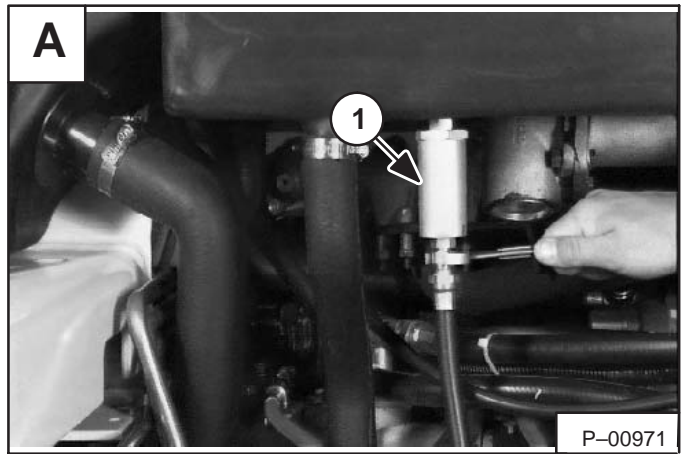

Loosen and disconnect the reservoir outlet hose **[B]**.

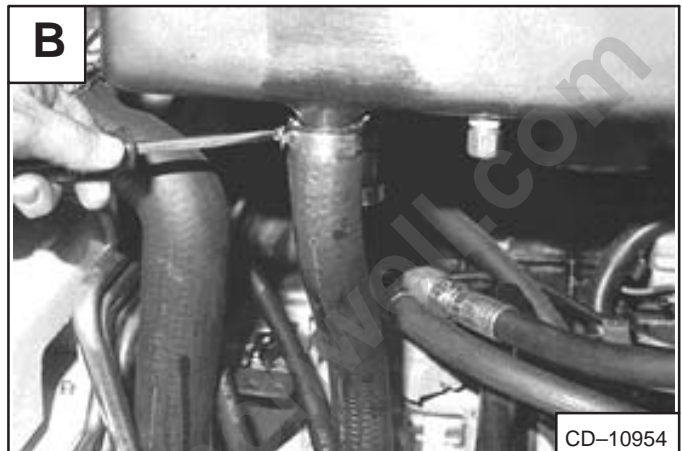

Remove the bolt and plate (Item 1) **[C]** from the mounting strap.

Installation: Tighten the bolt to 16–20 ft.-lbs. (21–27 Nm) torque.

Remove the hydraulic reservoir from the loader.

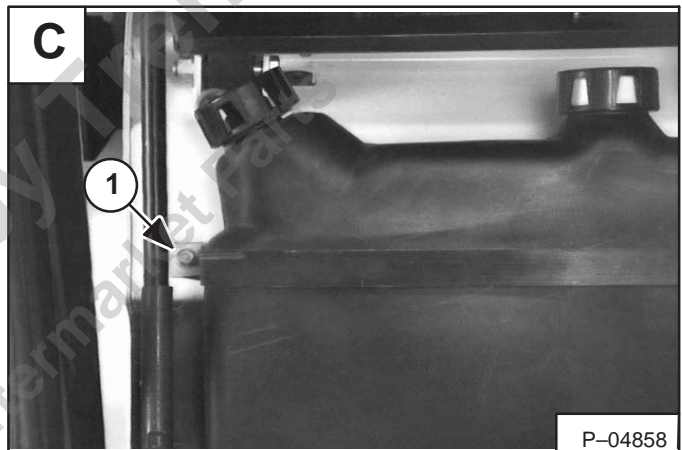

LOCK VALVE (S/N 5103)

Removal And Installation

NOTE: The lock valve is optional for the (S/N 5102) & the (S/N 5101) loaders.



WARNING

Never work on a machine with the lift arms up unless the lift arms are secured by an approved lift arm support device. Failure to use an approved lift arm support device can allow the lift arms or attachment to fall and cause injury or death.

W-2059-0598



DANGER

AVOID DEATH

- Disconnecting or loosening any hydraulic tubeline, hose, fitting, component or a part failure can cause lift arms to drop.
- Keep out of this area when lift arms are raised unless supported by an approved lift arm support. Replace if damaged.

53145

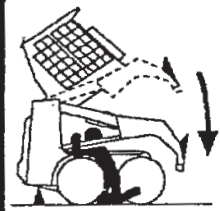

SW 98 6717343

Disconnect the two tubelines on the lock valve [A].

Remove the two (right) rear auxiliary hoses from the valve [B].

Remove the two (left) rear auxiliary hoses from the lock valve [C].

Remove the mounting bolt (Item 1) [C] and remove the lock valve.

Installation: Tighten the mounting bolt to 25 ft.-lbs. (34 Nm) torque.



WARNING

Always clean up spilled fuel or oil. Keep heat, flames, sparks or lighted tobacco away from fuel and oil. Failure to use care around combustibles can cause explosion or fire which can result in injury or death.

W-2103-1285

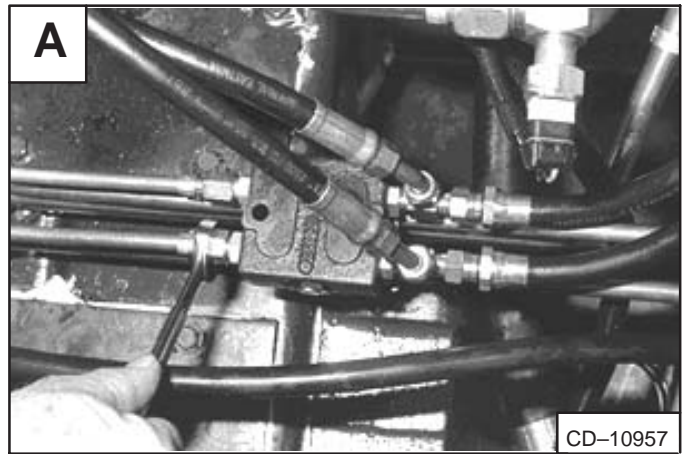

CD-10957

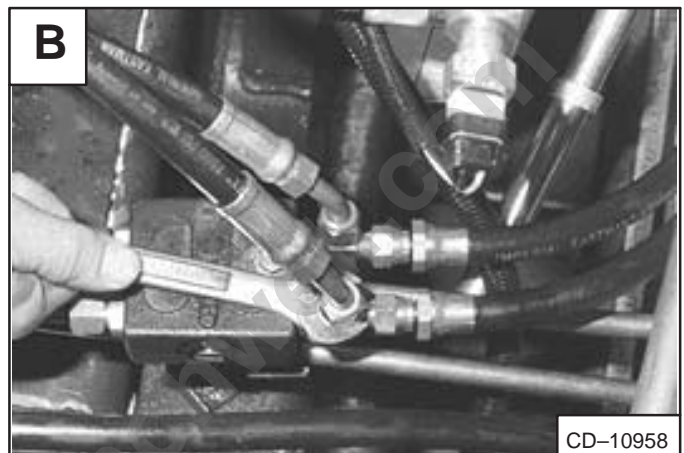

CD-10958

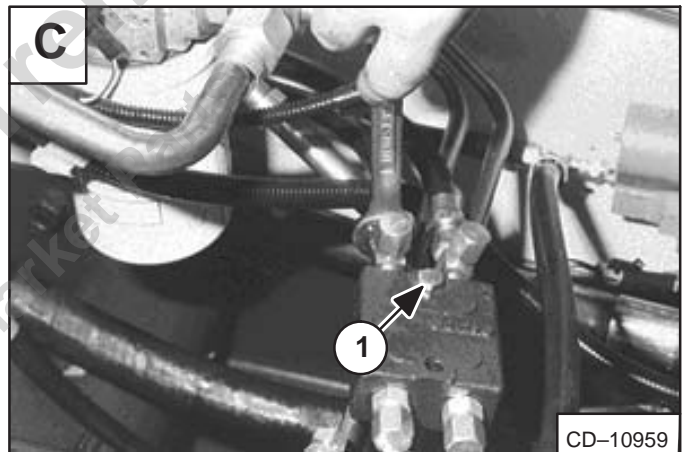

CD-10959

BUCKET POSITION VALVE (S/N 5102) & (S/N 5103)**Removal And Installation**

NOTE: The bucket position valve is optional for the (S/N 5101) loader.

WARNING

Never work on a machine with the lift arms up unless the lift arms are secured by an approved lift arm support device. Failure to use an approved lift arm support device can allow the lift arms or attachment to fall and cause injury or death.

W-2059-0598

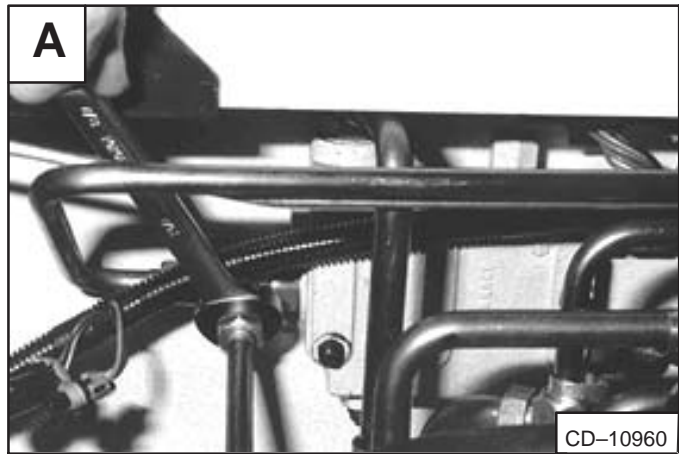

CD-10960

DANGER

AVOID DEATH

- Disconnecting or loosening any hydraulic tubeline, hose, fitting, component or a part failure can cause lift arms to drop.
- Keep out of this area when lift arms are raised unless supported by an approved lift arm support. Replace if damaged.

53145

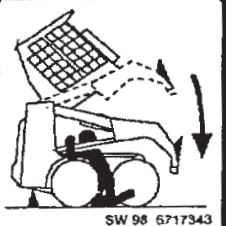

SW 98 6717343

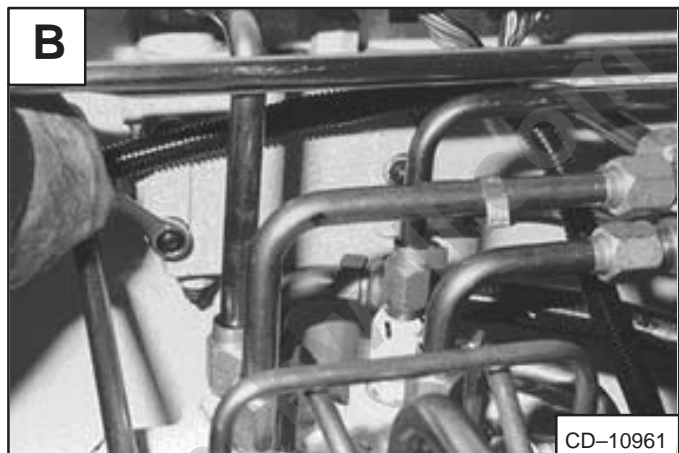

CD-10961

Remove all the tubelines connected to the valve [A].

Remove the two mounting bolts and remove the valve [B].

Installation: Tighten the mounting bolts to 15–16 ft.-lbs. (20–22 Nm) torque.

WARNING

Always clean up spilled fuel or oil. Keep heat, flames, sparks or lighted tobacco away from fuel and oil. Failure to use care around combustibles can cause explosion or fire which can result in injury or death.

W-2103-1285

FRONT AUXILIARY CONTROL VALVE (Apitech)

Removal And Installation

(S/N 508411001 – 15215)
 (S/N 509711001 & Above)
 (S/N 510375001 & Above)
 (S/N 510125001 – 16791) (W/Front Aux. Opt.)
 (S/N 510250001 – 50691)
 (S/N 512811001 & Above) (Ww/Apitech)

!
WARNING

Never work on a machine with the lift arms up unless the lift arms are secured by an approved lift arm support device. Failure to use an approved lift arm support device can allow the lift arms or attachment to fall and cause injury or death.

W-2059-0598

!
DANGER

AVOID DEATH

- Disconnecting or loosening any hydraulic tubeline, hose, fitting, component or a part failure can cause lift arms to drop.
- Keep out of this area when lift arms are raised unless supported by an approved lift arm support. Replace if damaged. 531 45

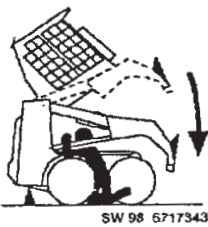

SW 98 6717343

Disconnect the outlet tubeline which returns to the hydraulic filter [B].

Disconnect the two auxiliary tubelines [B].

Disconnect the solenoid connector [C].

Remove the two mounting bolts and remove the auxiliary control valve [D].

Installation: Tighten the mounting bolts to 64–70 ft.-lbs. (88–95 Nm) torque.

!
WARNING

Always clean up spilled fuel or oil. Keep heat, flames, sparks or lighted tobacco away from fuel and oil. Failure to use care around combustibles can cause explosion or fire which can result in injury or death.

W-2103-1285

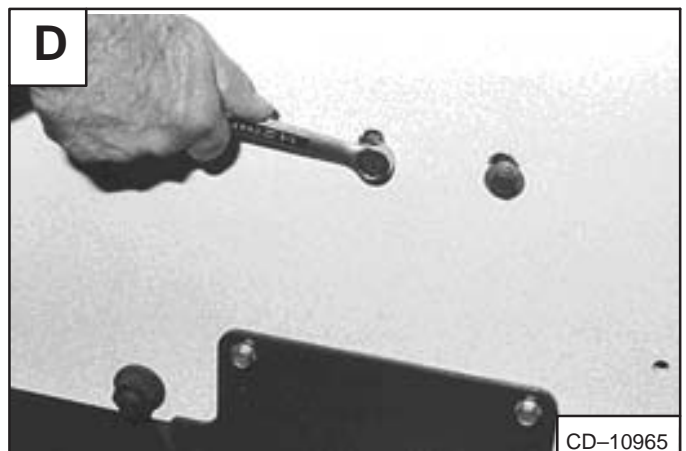
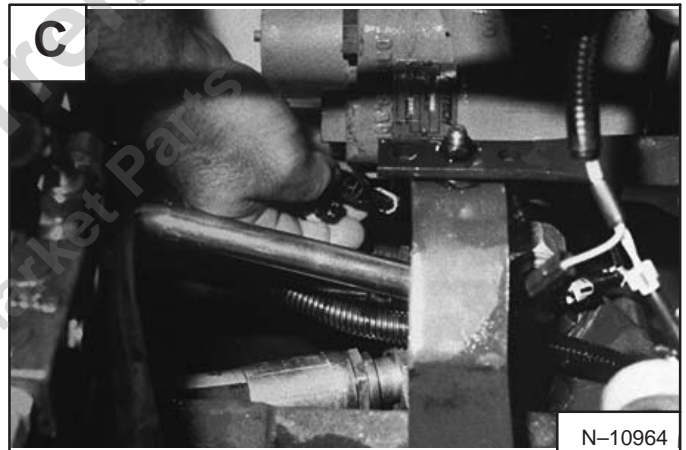
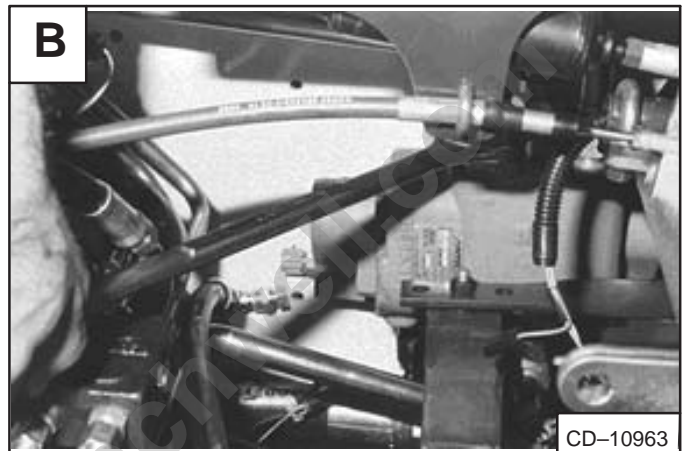
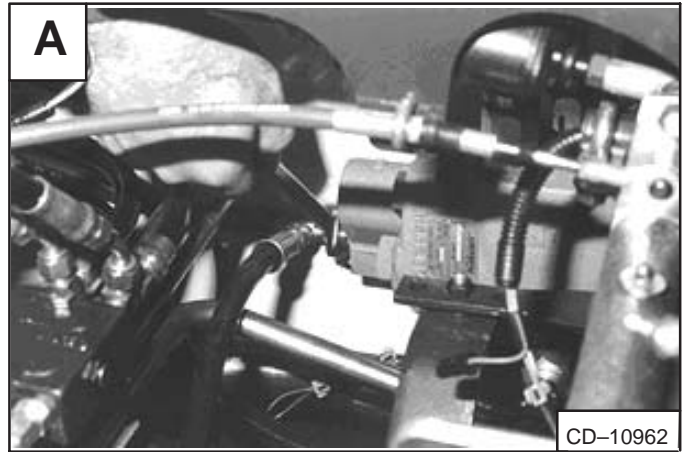

CONTROL PEDALS

Removal And Installation

Remove the bolt and nut (Item 1) [A] from the pedal linkage.

Installation: Tighten the bolt and nut to 21–25 ft.-lbs. (28–34 Nm) torque.

Check the rubber bushing in the pedal for wear and replace as needed.

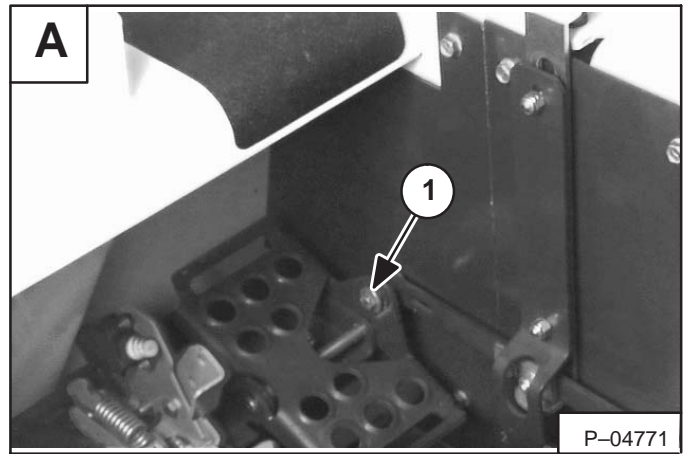

Remove the two mounting bolts (Item 1) [B].

Remove the pedal assembly from the loader.

Pedal Adjustment

After installing the pedal, adjust the pedal so that there is clearance under the rear of the pedal and the valve spool must travel full stroke without hitting the floor panel.

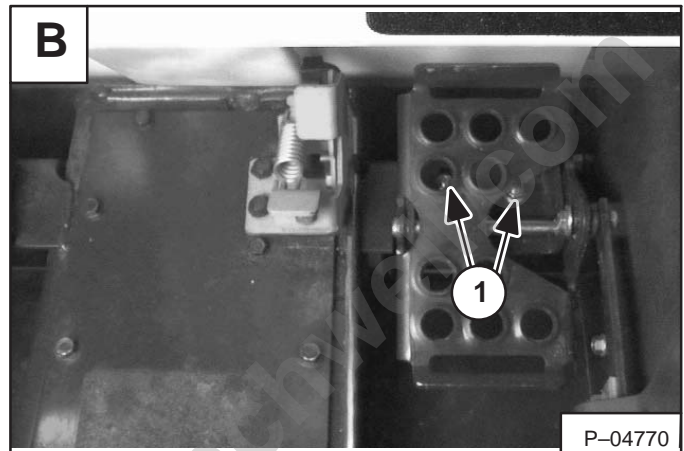

WARNING

AVOID INJURY OR DEATH

Adjust locking tabs on pedal control linkage so that lift and tilt control pedals are locked in neutral when the seat bar is up.

W-2104-1285

NOTE: See Page 2-44 for correct procedure to adjust the pedal interlock linkage.

PEDAL INTERLOCK LINKAGE

Removal And Installation

Raise the lift arms and install an approved lift arm support device. (See Page 1-1.)

Raise the operator cab. (See Page 1-1.)

Remove the interlock shield mounting nuts (Item 1) [A].

Installation: Tighten the shield mounting nuts to 25–28 ft.-lbs. (34–38 Nm) torque.

Remove the interlock shield (Item 2) [A].

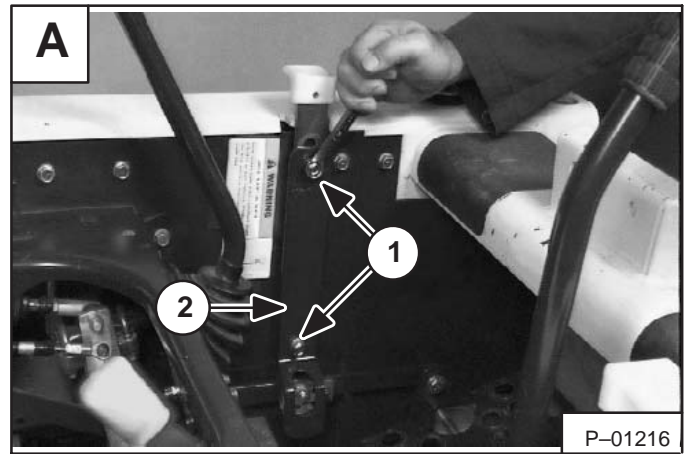

Remove the interlock mounting nuts and plastic washers from behind the nuts [B].

Remove the interlock (Item 1) [B] and plastic washers from behind the interlock.

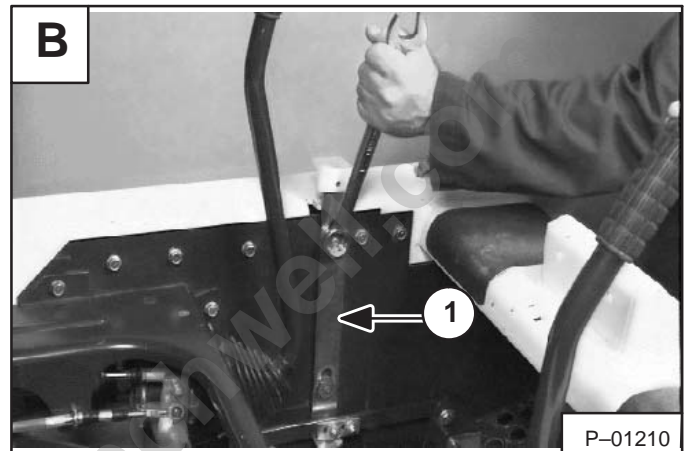

Installation: Hold the inside plastic washer up with an O-ring pick or a small screwdriver so the plastic washer does not become wedged between the side panel and the interlock nut [C].

Installation: Tighten the interlock mounting nuts to 84–95 in.-lbs. (9,5–10,8 Nm) torque.

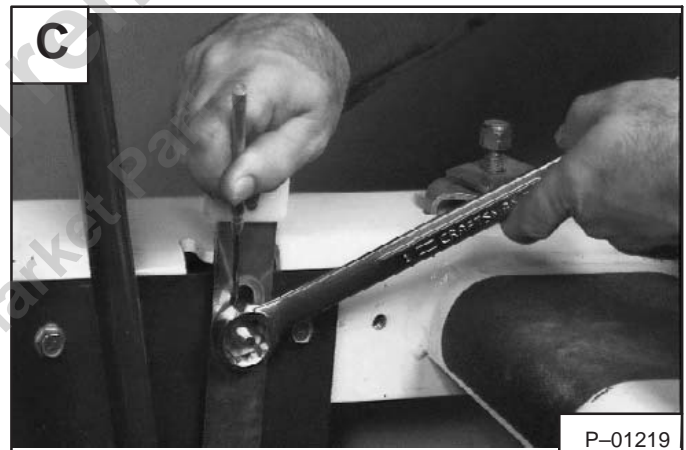

To install new interlock mounting bolts, remove the top bolt from the front panel and loosen the two bolts at the bottom of the panel [D].



PEDAL INTERLOCK LINKAGE (Cont'd)**Removal And Installation (Cont'd)**

Remove the panel from the loader frame [A].

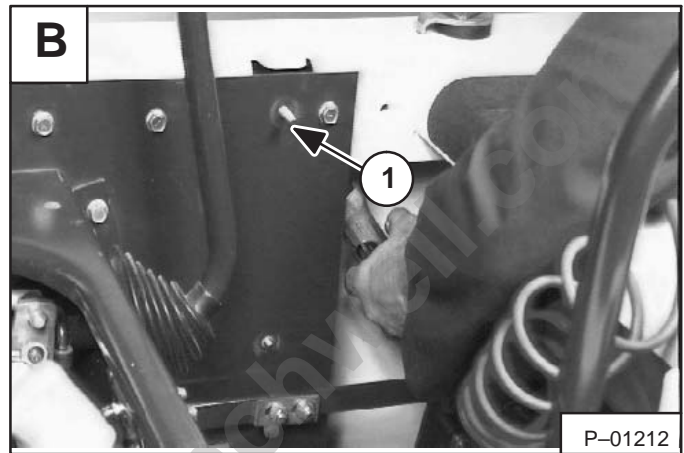

Install the mounting bolts (Item 1) [B] through the back of the panel as shown.

**Pedal Interlock Linkage Adjustment**

Check the pedal interlock linkage so it is free and locks both pedals.

Check that the tab (Item 1) [C] on the linkage, slides into the slot on the interlock and holds the pedal in locked position.

If not, loosen the bolts and adjust the tab for correct engagement.

Tighten the bolts to 25–28 ft.-lbs. (34–38 Nm) torque.

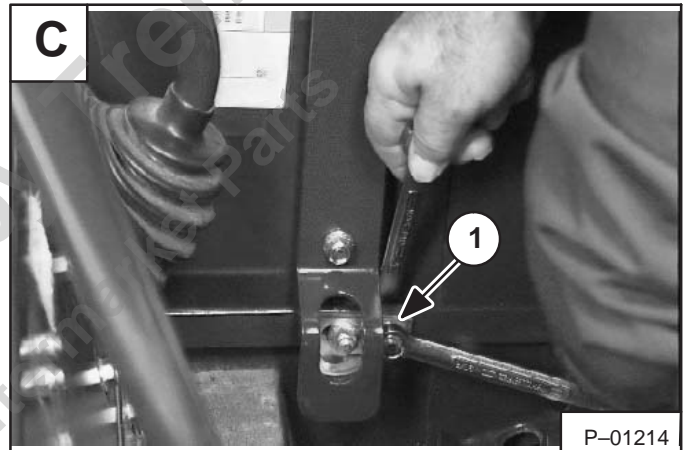

⚠ WARNING

AVOID INJURY OR DEATH

Adjust locking tabs on pedal control linkage so that lift and tilt control pedals are locked in neutral when the seat bar is up.

W-2104-1285

The locking tab should fit into the slot of the interlock as shown in figure [D], when adjusted correctly.

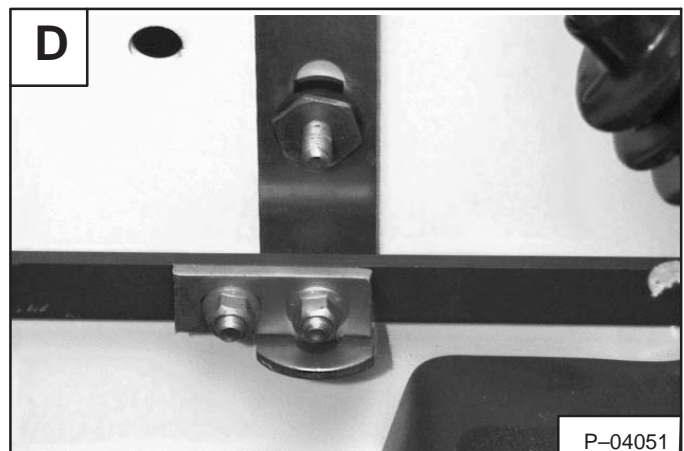

HYDROSTATIC SYSTEM

	Page Number
COLD OIL BY-PASS VALVE Removal And Installation	3-21
DRIVE BELT Replacing The Drive Belt	3-27
DRIVE BELT SHIELD Removal And Installation	3-26
FIXED TENSIONER PULLEY Adjusting The Drive Belt	3-41
Assembly	3-36
Checking Pulley End Play	3-40
Disassembly	3-34
Removal And Installation	3-33
FRONT PANEL Removal And Installation	3-5
HYDROSTATIC CHARGE OIL FILTER Removal And Installation	3-19
HYDROSTATIC MOTOR Removal And Installation	3-17
HYDROSTATIC PUMP Removal And Installation	3-23
Replenishing/High Pressure Relief Valve	3-25
HYDROSTATIC SYSTEM INFORMATION Replenishing Valve Function	3-4
Tow Valves	3-4
OIL COOLER Removal And Installation	3-42
SPRING LOADED TENSIONER PULLEY Adjusting The Drive Belt	3-32
Assembly	3-30
Disassembly	3-29
Parts Identification	3-28
STEERING LEVERS Adjusting Lever Freeplay	3-10
Adjusting The Steering Neutral Setting	3-13
Adjusting The Wheel RPM Forward Compared To Reverse Travel ...	3-11
Adjusting The Wheel RPM Left Compared To Right Side	3-14
Disassembly And Assembly	3-7
Neutral Pre-Adjustment Checks	3-9
Hydrostatic Pump Neutral Adjustment	3-15
TROUBLESHOOTING Chart	3-3

HYDROSTATIC
SYSTEM



TROUBLESHOOTING**Chart**

The following troubleshooting chart is provided for assistance in locating and correcting problems which are most common. Many of the recommended procedures must be done by authorized Bobcat Service Personnel only.

**WARNING**

Check for correct function after adjustments, repairs or service. Failure to make correct repairs or adjustments can cause injury or death.

W-2004-1285

PROBLEM	CAUSE
No drive on one side, in one direction.	1, 2
No drive on one side in both directions.	2, 3, 4, 5
The loader does not move in a straight line.	2, 3, 5, 6, 7
The hydrostatic system is overheating.	8, 9, 10, 11
Service code HP 2 appears (Warnings, low charge pressure) or the warning light comes ON (853 Base).	8, 11, 12, 13, 14

KEY TO CORRECT THE CAUSE

1. The hydrostatic pump replenishing valves not seating.
2. The steering linkage needs adjustment.
3. The hydrostatic pump has damage.
4. The final drive chains are broken.
5. The hydrostatic motor has damage.
6. The tires do not have the correct tire pressure.
7. The tires are not the same size.
8. The hydrostatic fluid is not at the correct level.
9. The oil cooler has a restriction.
10. The temperature sending switch is not operating correctly.
11. The loader is not being operated at the correct RPM.
12. The sender is defective.
13. Pump is defective or worn hydrostatics.
14. Hydraulic filter is plugged.

HYDROSTATIC SYSTEM INFORMATION

IMPORTANT

When making repairs on hydrostatic and hydraulic systems, clean the work area before disassembly and keep all parts clean. Always use caps and plugs on hoses, tubelines and ports to keep dirt out. Dirt can quickly damage the system.

I-2003-0284

Replenishing Valve Function

The functions of the replenishing valves are:

1. To give replacement fluid to the low pressure side of the hydrostatic circuit. Replacement fluid is needed because of normal internal leakage and the controlled flow to the oil cooler for cooling; Function 1 [A].
2. To keep high pressure fluid out of the low pressure side of the hydrostatic circuitry; Function 2 [A].

Tow Valves

The loader can be moved for a short distance when the tow valves are open.

Turn the two valves open one half turn before moving the loader [B] [C].

NOTE: After moving the loader with the tow valves open, make sure the two valves are completely closed and tight because they have a direct effect on the operation of the loader drive system.

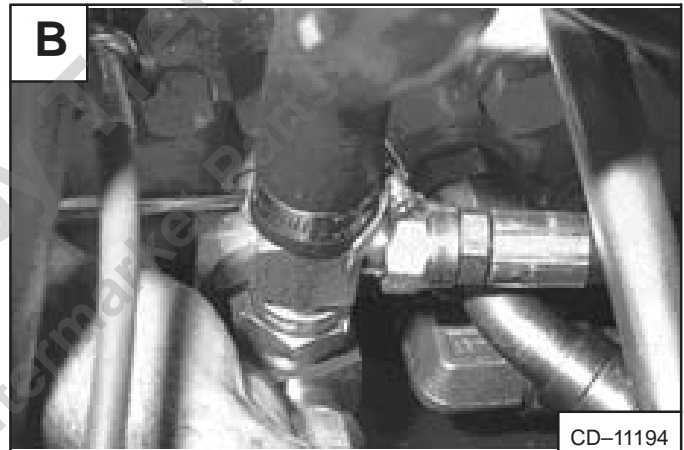
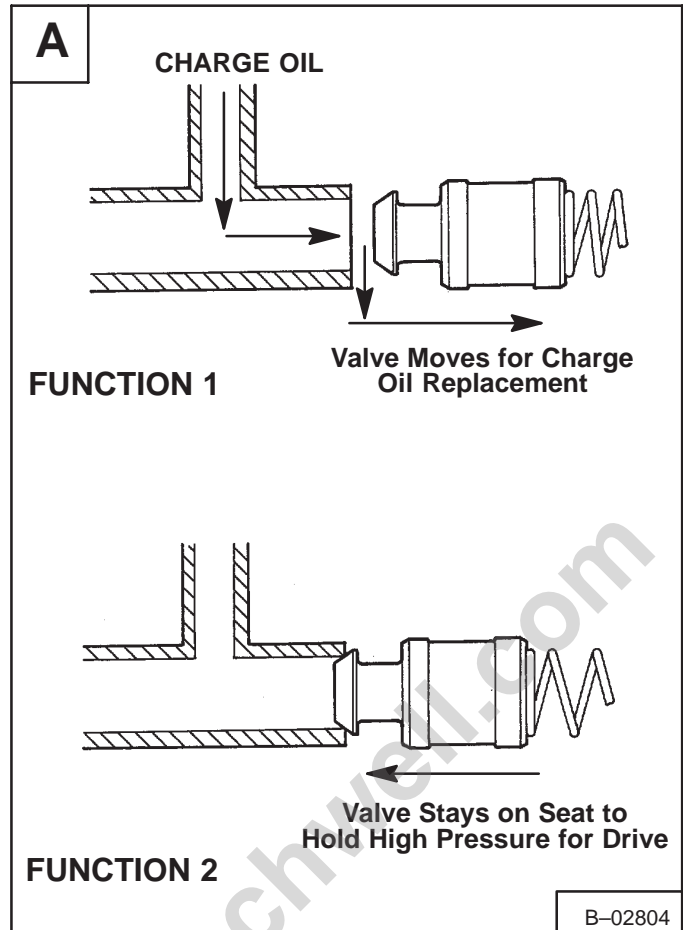

FRONT PANEL

Removal And Installation

**WARNING**

Put jackstands under the front axles and rear corners of the frame before running the engine for service. Failure to use jackstands can allow the machine to fall or move and cause injury or death.

W-2017-0286

**WARNING**

Never work on a machine with the lift arms up unless the lift arms are secured by an approved lift arm support device. Failure to use an approved lift arm support device can allow the lift arms or attachment to fall and cause injury or death.

W-2059-0598

Raise the operator cab. (See Page 1-1.)

Remove the mounting bolts (Item 1) [A] from the throttle lever.

Disconnect the linkage rod (Item 1) [B] from the throttle lever.

Disconnect the wire harness connectors (Item 1) [C] from the steering lever wire harness.

NOTE: The 853 without front auxiliary hydraulics does not have electric control handle.

Remove the right side steering shock (Item 2) [D].

NOTE: Early S/N loaders do not have steering panel braces (Item 3) [C]. The right side steering shock is mounted inside the steering panel.

Remove the steering panel brace bolts (Item 1) [D].

NOTE: Bolts have a nut on rear side holding panel brace.

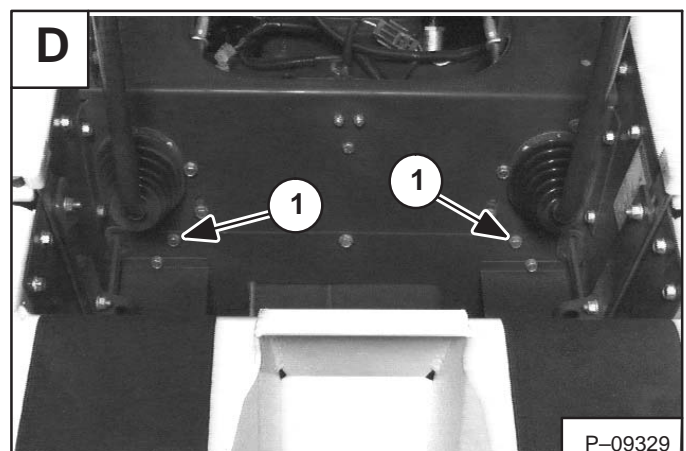
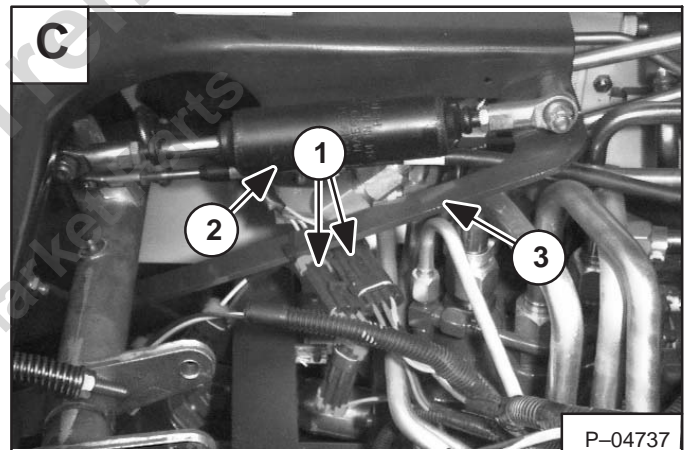
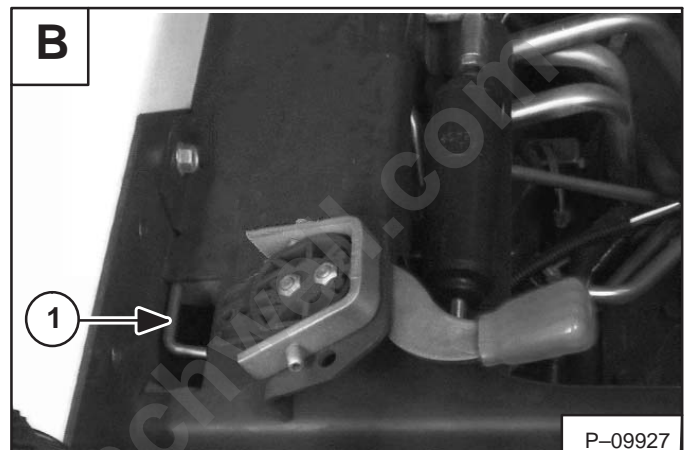
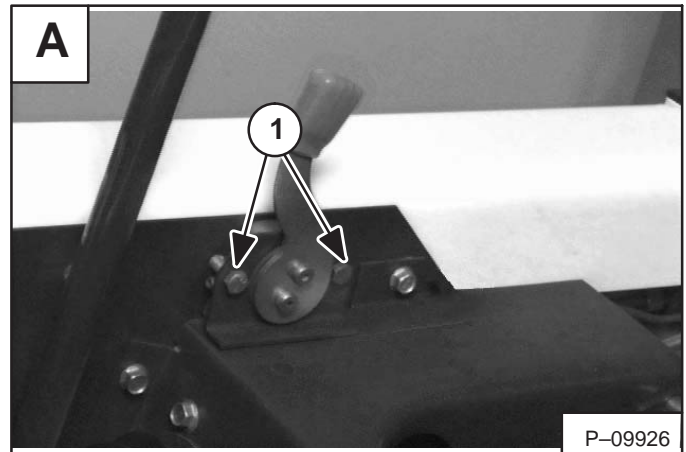

FRONT PANEL (Cont'd)**Removal And Installation (Cont'd)**

Remove the steering cable U-bolt (Item 1) [A].

Disconnect the steering cable ball joint (Item 2) [A].

Remove the steering panel brace (Item 3) [A].

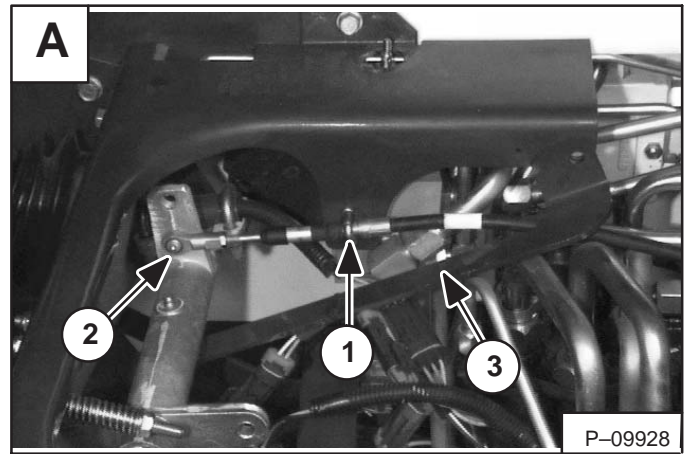

Remove the top mounting bolts (Item 1) [B] (both sides).

Remove the shock absorber mounting bolt (Item 2) [B].

Disconnect the shock absorber panel brace bolt (Item 3) [B]. Remove panel brace and shock.

Installation: Connect the bottom panel brace (both sides) prior to connecting shock absorber/panel brace bolt (Item 3) [B]. Lift upward on rear edge of panel to align panel and brace.

Remove the steering cable U-bolt (Item 4) [B].

Disconnect the steering cable ball joint (Item 5) [B].

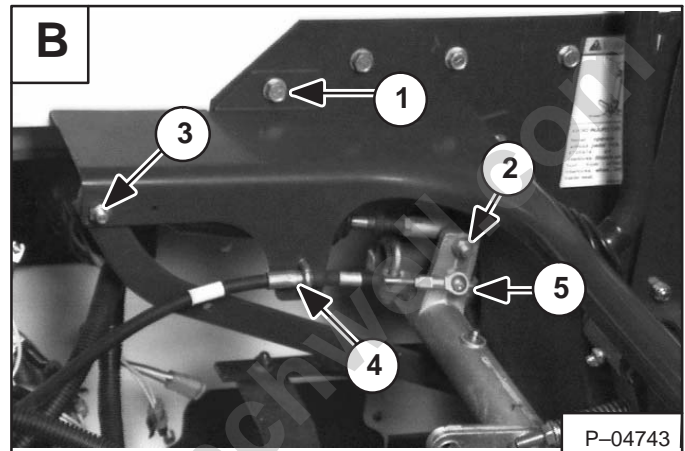

Remove the two mounting bolts (Item 1) [C] at the side of the front panel (both sides).

Remove the mounting bolt (Item 2) [C] on the bottom of the front panel.

Remove the front panel.

Installation: Align pedal link grommets in steering panel and lower cover slots (Item 3) [C].

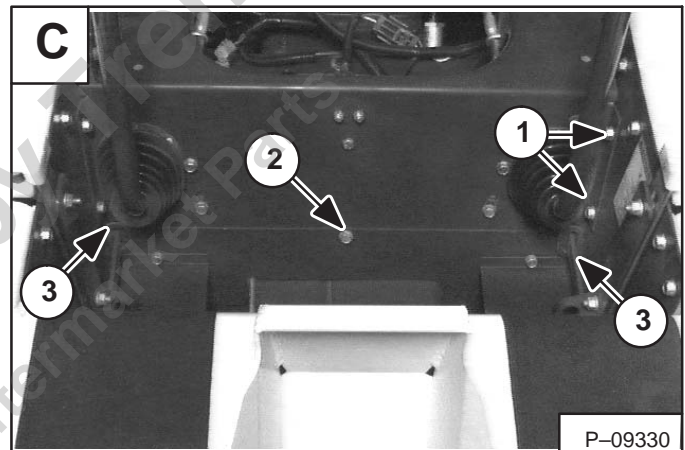

STEERING LEVERS

Disassembly And Assembly

Remove the front panel/steering lever assembly. (See Page 3–5.)

Remove the steering shaft centering mechanism bolt and nut (Item 1) [A] and spring.

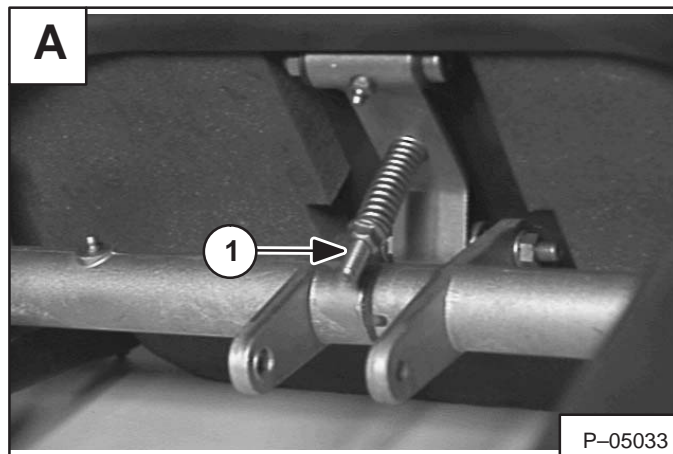

Disconnect the steering shock (Item 1) [B].

Loosen both U-bolts (Item 2) [B] at the steering lever.

Remove the steering lever.

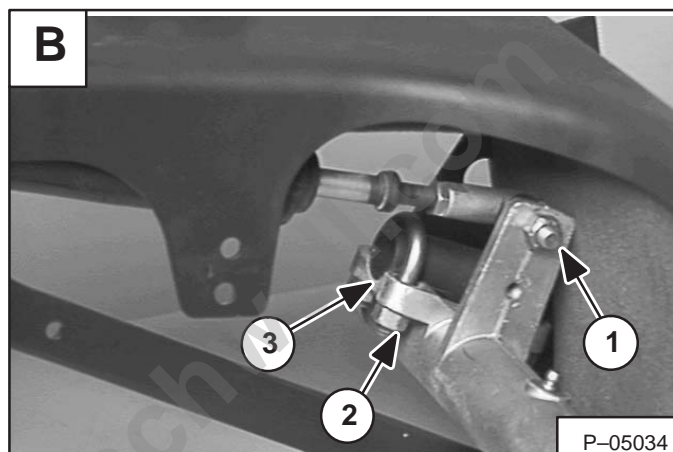

Loosen both U-bolts (Item 1) [C] at the steering lever.

Remove the steering lever.

Assembly: The steering levers must be mounted flush with the back of the mounting plate (Item 3) [B].

Remove the steering shaft assembly bolts (Item 2) [C] (both sides).

Remove the steering shaft.

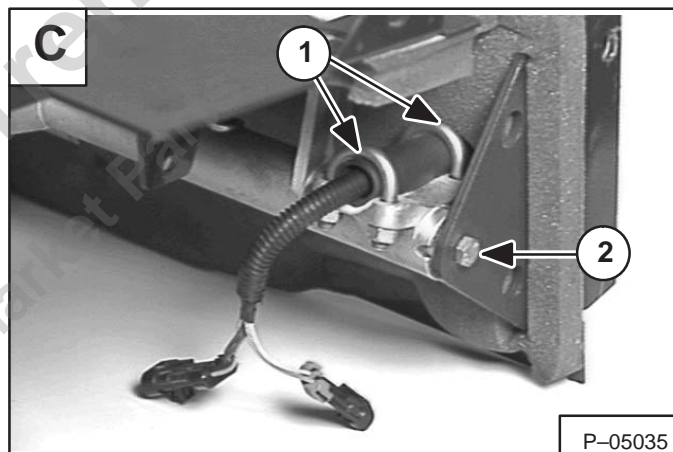

Disassemble the right and left steering shaft from the cross shaft [D].

Install new nylon bushings (Item 1) [D] as needed at the ends of the steering shaft.

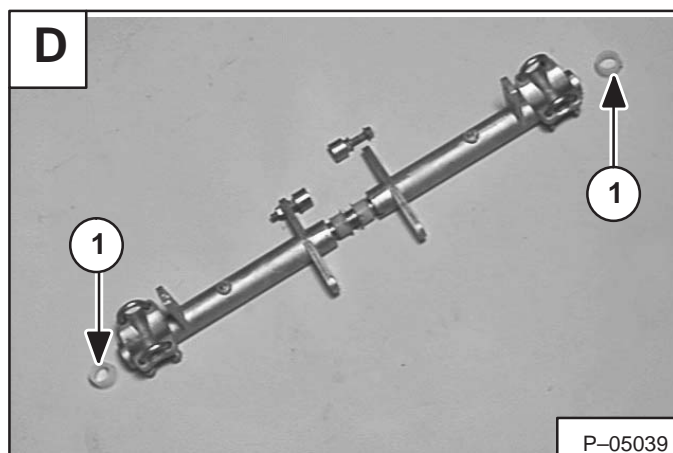

STEERING LEVERS (Cont'd)

Disassembly And Assembly (Cont'd)

Check the nylon bushing (Item 1) [A] and replace as needed.

Assembly: Make sure the wave washer (Item 2) [A] is between the nylon bushings.

Check and replace the cams (Item 3) [A] if worn or damaged.

NOTE: The cams must not rotate on the mounting bolts.

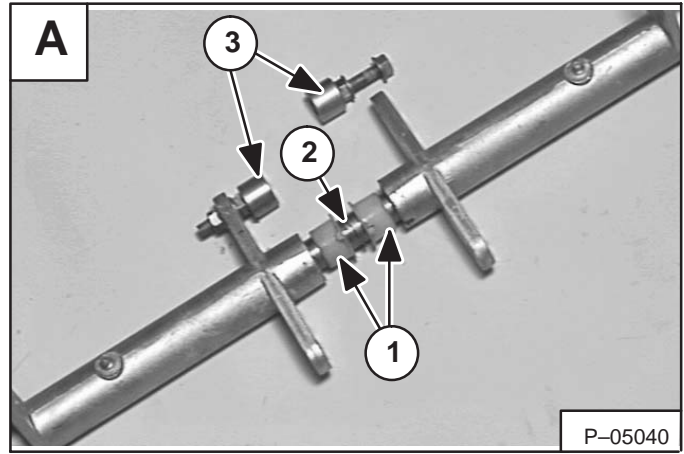

Remove the bolts (Item 1) [B] to remove the steering shaft mounting bracket (Item 1) [C] and the steering lever stop plate (Item 2) [C].

NOTE: Early S/N loaders do not have the stop plate (Item 2) [C].

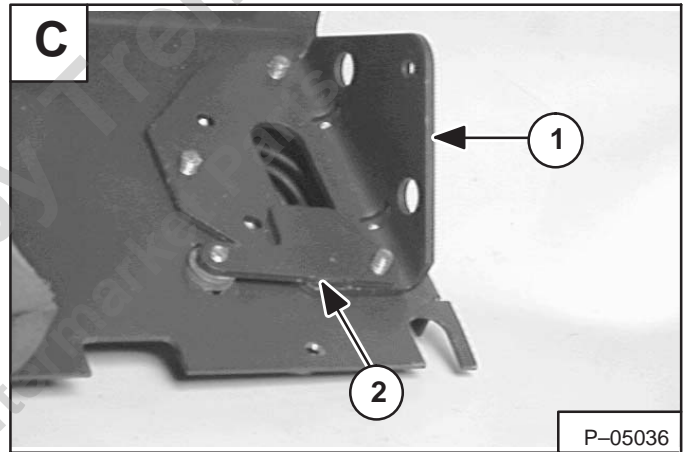
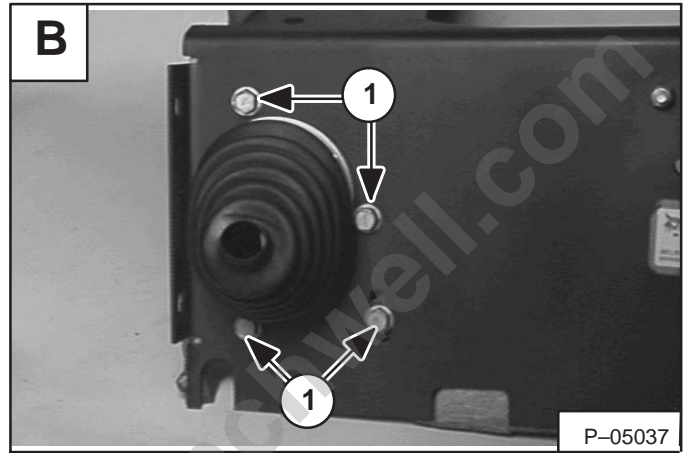

To remove the centering mechanism bracket from the front panel, remove the two nuts and bolts (Item 1) [D].

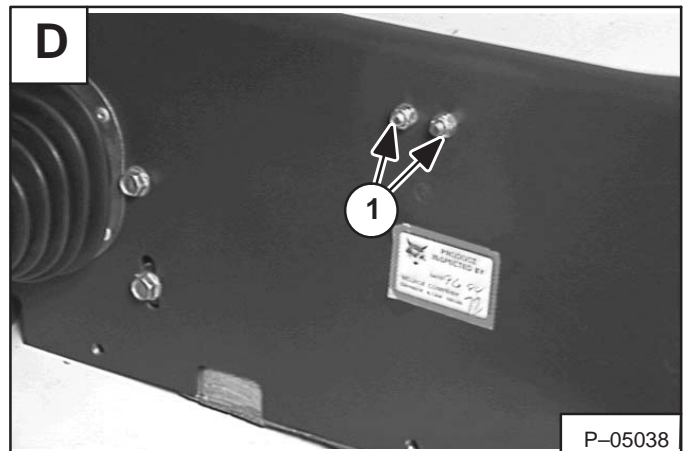

STEERING LEVERS (Cont'd)**Neutral Pre-Adjustment Checks**

Read this adjustment completely to become familiar with the procedure before beginning the adjustment.

The loader should not creep (slow wheel movement) when the steering levers are at rest in the neutral position.

The following special tool will be needed to do the following procedure:

MEL1429A – Remote Start Switch

Lift and block the loader. (See Page 1-1.)

Raise the operator cab. (See Page 1-1.)

Connect the remote start switch. (See Page 1-1.)



WARNING

When working on the left side of the hydrostatic pump, BE CAREFUL to keep your fingers and tools clear of the cooling fan belt.

W-2184-0395

Check the following items (Steps 1, 2 & 3) before making any adjustments on the steering linkage:

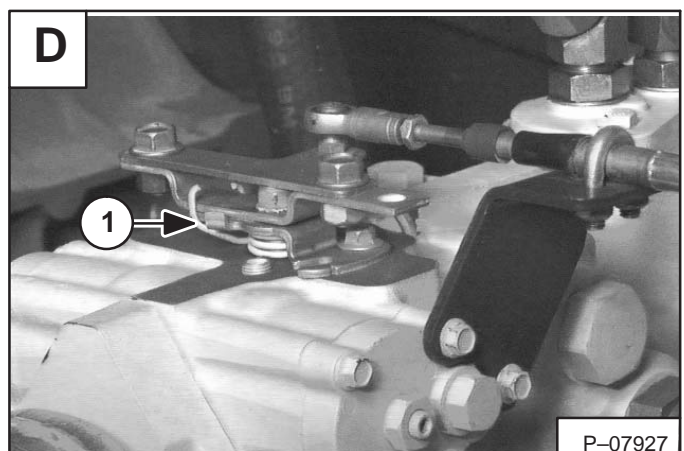
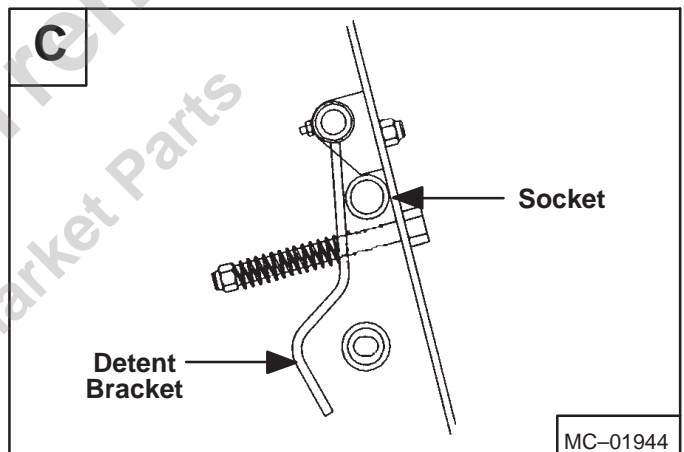
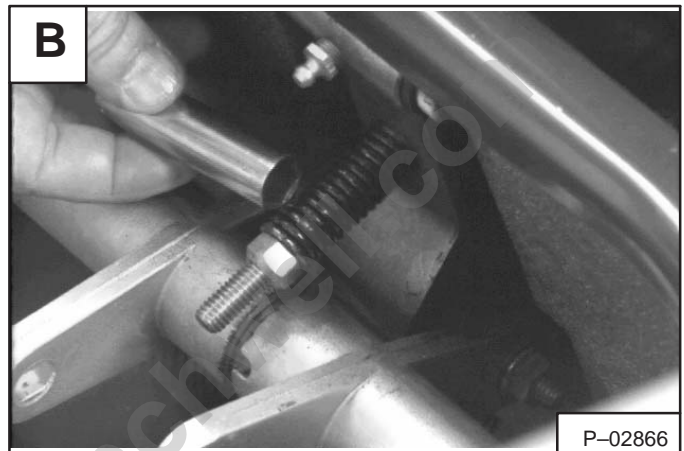
1. Always check tire pressure and tire size before making any adjustments. Inflate tires to maximum pressure shown on the sidewall of the tire. Be sure the tires do not vary more than 1 inch (25,4 mm) in circumference [A] which could cause different rate of travel and the loader drifting to one side with both steering levers at equal travel.
2. To be sure the hydrostatic pump is in neutral, block the neutral spring bracket out with a deep socket (approximately 7/16 inch) so you can no longer feel the linkage neutral setting [B] & [C].
3. Start the engine. Move the levers while observing the neutral position on the pump servo spool valve. You can feel and see the spring (Item 1) [D] of the pump neutral adjustment. If the wheels do not move when the pump is in the neutral position, then the pump is correctly adjusted. Only linkage adjustment will be necessary for neutral position. If the wheels move when the pump levers are in neutral position, see Page 3-15 for the pump neutral adjustment.
4. Stop the engine. Remove the socket [B].



STEERING LEVERS (Cont'd)**Adjusting Lever Freeplay**

Read this adjustment completely to become familiar with the procedure before beginning the adjustment.

Use the following procedure to adjust the steering linkage so both steering levers have no **free play** against the cam. To remove the **free play**, move the right cam to match the left cam so there is no **free play** between the two cams in the pocket of the detent bracket [C]. Use the following procedure to adjust the the cam free play.

1. Only the right side cam is adjustable in slotted hole in bellcrank (Item 1) [B]. The left side cam is fixed and will not require adjustment. The cam should not rotate on the mounting bolt. If cam rotates, tighten the jam nut (Item 1) [A] against the cam while holding cam mounting bolt (Item 3) [A].
2. Loose the cam mounting bolt nut (Item 2) [A] and move the cam to the rear to get free play in the left hand lever.
3. Tighten the cam bolt. Use a punch and hammer, hit the cam nut (cam mounting bolt is still tight) until the **free play** is removed from the left hand lever [B]. The cam must be centered in the detent bracket pocket [C].
4. Recheck the torque at the cam bolt to be sure it is still tight. Check again to be sure there is no free play in the cams. **If there is any free play the neutral setting can not be obtained.**

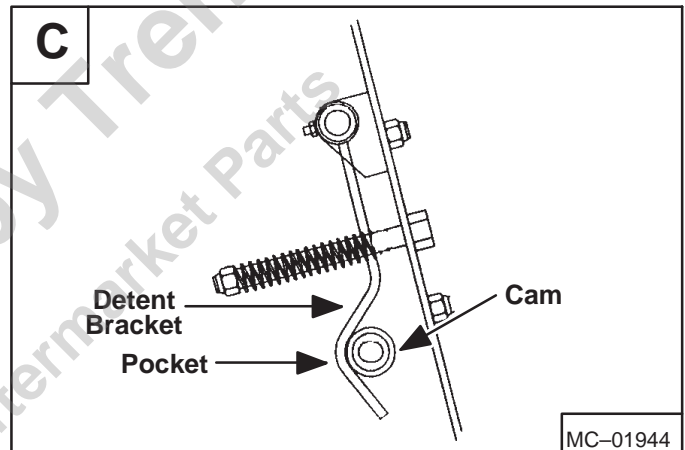
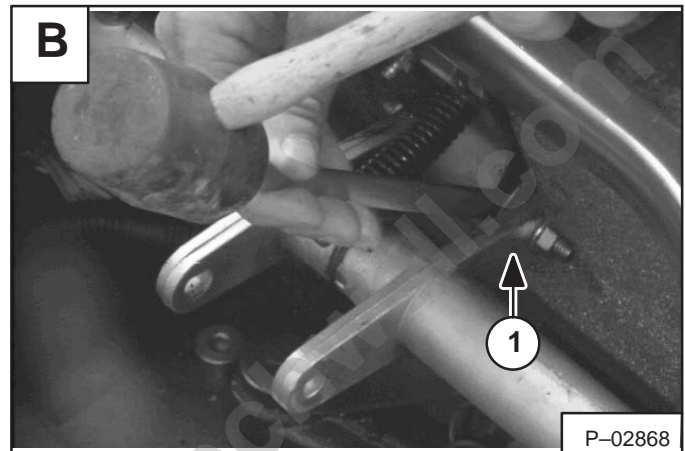
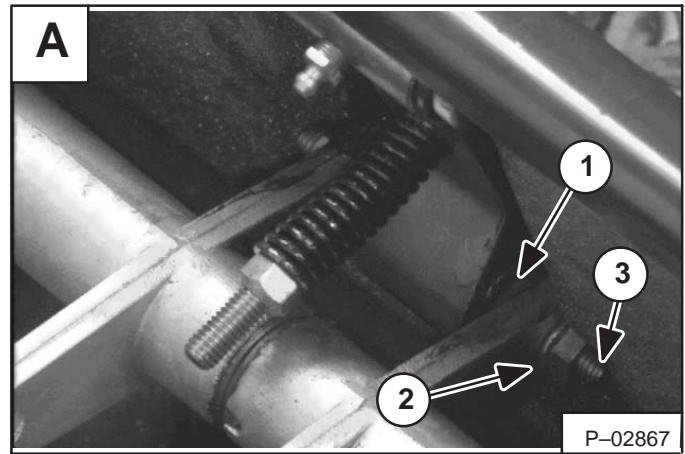

STEERING LEVERS (Cont'd)**Adjusting The Wheel RPM Forward Compared To Reverse Travel**

Read this adjustment completely to become familiar with the procedure before beginning the adjustment.

NOTE: This procedure adjusts the position of the steering levers in the panel when in neutral. Levers centered in steering panel give equal travel forward compared to reverse.

1. Disconnect the two bolts of the pintle links (both sides) (Item 1) [A].
2. Fully lower steering lever stop and tighten (both sides) (Item 1) [B].

NOTE: Before measuring, move the steering lever a small amount to be sure the cam is in the detent pocket with no freeplay.

3. Move the lever to full forward, measure the distance from the U-bolt to the lock nut. Record this measurement [C].

EXAMPLE ONLY: 3.66 inch (82,0 mm)

4. Move the lever to full reverse, measure the distance from the U-bolt to the lock nut. Make a record of this measurement [D].

EXAMPLE ONLY: 2.76 inch (70,0 mm)

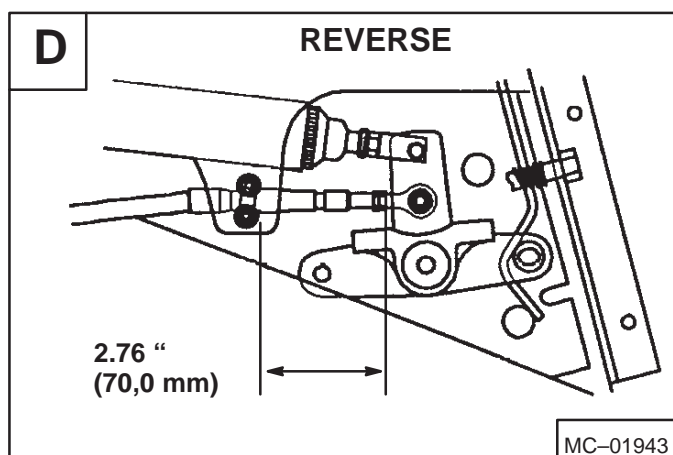
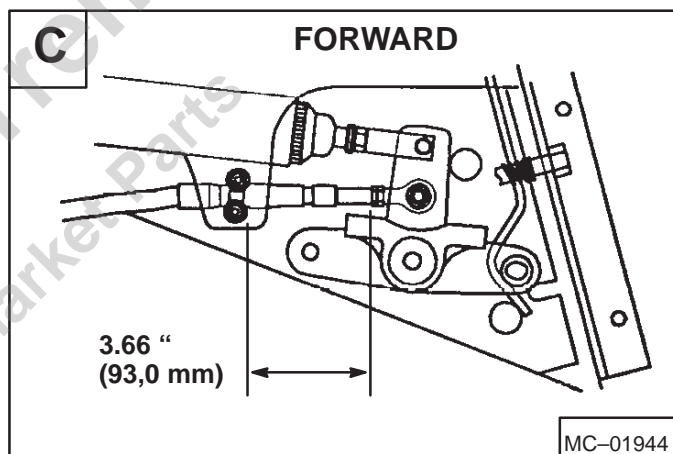
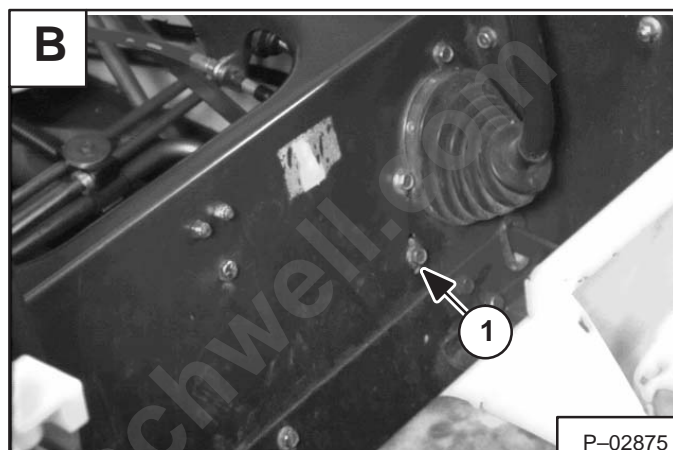
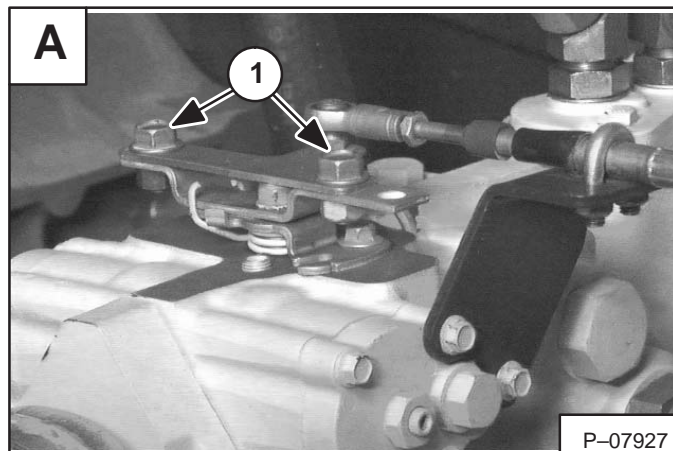

STEERING LEVERS (Cont'd)

Adjusting The Wheel RPM Forward Compared To Reverse Travel (Cont'd)

5. Move the lever to the neutral position. Measure the distance from the U-bolt to the lock nut [A]. Neutral must be adjusted to 3.21 inch (82 mm) per example.

EXAMPLE:

Forward	3.66 inch (93,0 mm)
Reverse	- 2.76 inch (70,0 mm)
	0.90 inch (23,0 mm) Total Travel*

Divided by Two = 0.45 inch (11,0 mm) Half the Travel
 + 2.76 inch (70,0 mm) Reverse Travel
 3.21 inch (82,0 mm) Is Neutral

If adjustment is required, loosen the mounting bolts (Item 1) [B].

Moving the neutral spring bracket up will allow more forward stroke and more forward wheel RPM. Moving it down will allow more rearward stroke and more reverse wheel RPM.

Use a screwdriver to move the neutral spring bracket (Item 1) [C] down or a large pliers to move it up in its slotted holes.

NOTE: Keep the bracket vertical to be sure that the cams make full contact in the pocket of the detent bracket.

Tighten the mounting bolts on the spring bracket (Item 1) [B].

Neutral to forward cable travel must be within 0.010 inch (0,25 mm) left compared to right side.

Install pintle link bolts (Item 1) [D] (both sides).

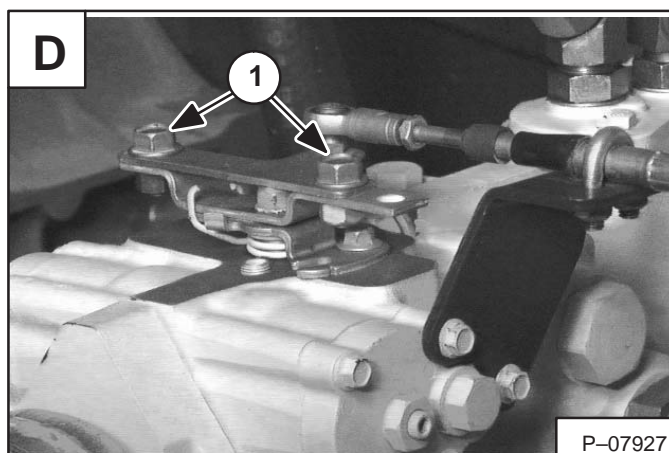
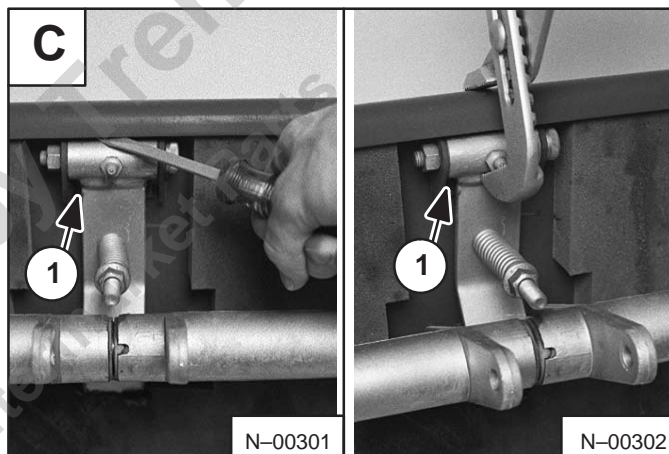
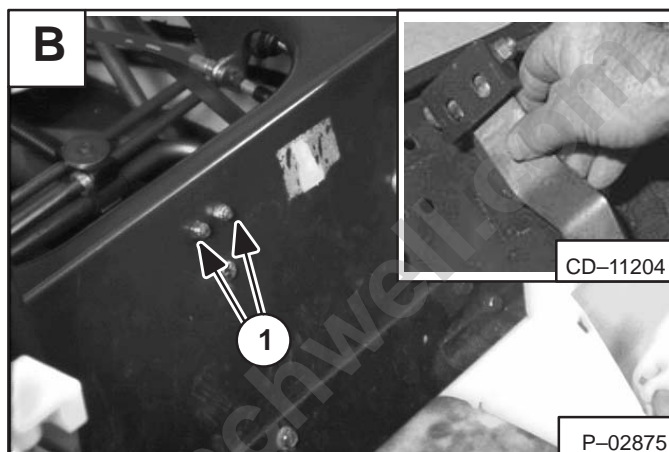
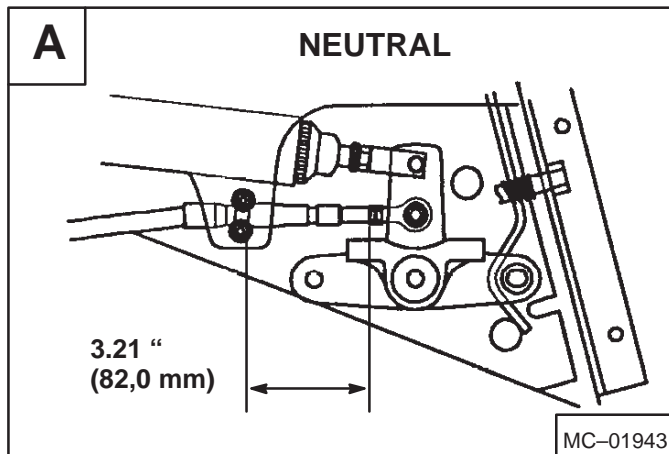

STEERING LEVERS (Cont'd)**Adjusting The Steering Neutral Setting**

Read this adjustment completely to become familiar with the procedure before beginning the adjustment.

NOTE: This procedure adjusts the creep (wheel movement in neutral) and dead-band (lever travel before wheels start to turn). Adjusting steering cable length will match lever neutral and pump neutral.

NOTE: The following adjustments (Steps a, b, c & d) are not necessary if the thread engagement in the ball joint is equal on both ends of the cable (Item 1) [A] & [B].

- a. Disconnect the cable ball joint from the steering lever shaft (Item 2) [A].
 - b. Loosen the jam nut and turn the ball joint all the way to the end of the threads (toward cable housing).
 - c. At the pumps, loosen the jam nut and turn the inner cable until the ball joint is all the way to the end of the threads (toward the cable housing).
 - d. Connect the steering cable ball joint.
1. Start the engine. WHEN THE ENGINE IS RUNNING, THE WHEELS WILL BE TURNING.

! WARNING

Put jackstands under the front axles and rear corners of the frame before running the engine for service. Failure to use jackstands can allow the machine to fall or move and cause injury or death.

W-2017-0286

2. The steering cable ends have right and left hand threads. By turning the inner cable, it will shorten or lengthen the cable. Turn the inner cable until the wheels stop turning [C].

NOTE: Before measuring, move the steering lever a small amount to be sure the cam is in the detent pocket with no freeplay.

3. Use a straight edge for a measuring reference point positioned against the pedal lock links (Item 1) [D]. Put a ruler between reference and steering lever to measure lever travel from neutral until wheel starts to travel forward. Then measure from neutral until wheel starts to travel reverse [D].
4. Adjust cable length by turning the inner cable until the two measurements are equal [C]. Tighten the jam nut (both ends).
5. Repeat the procedure for the other side of the loader.

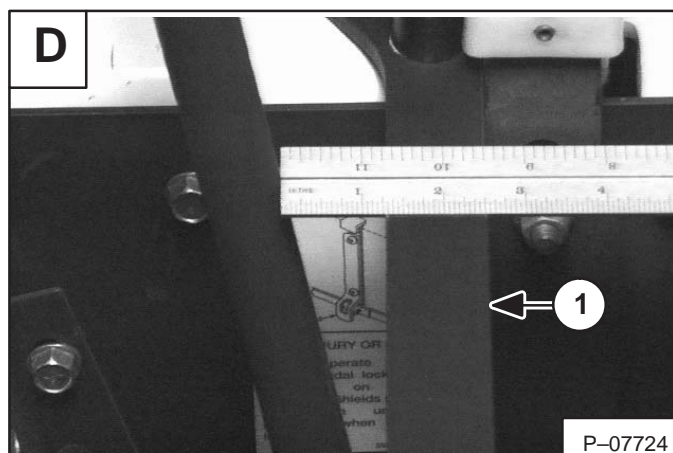
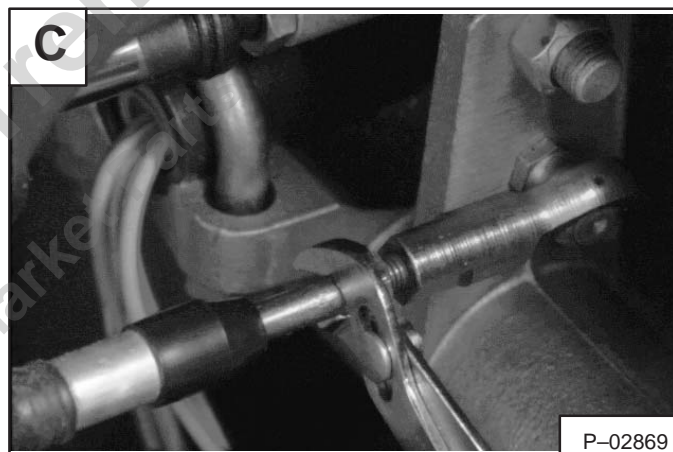
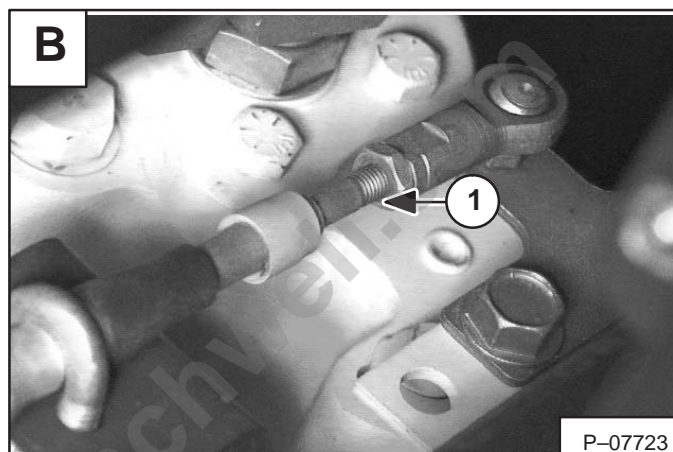
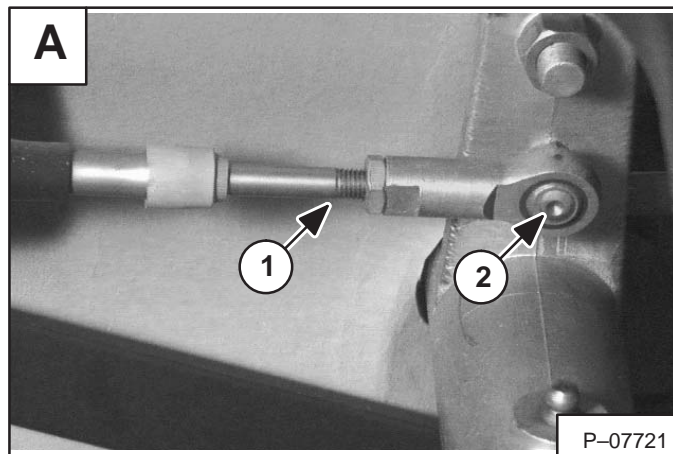

STEERING LEVERS (Cont'd)**Adjusting The Wheel RPM Left Compared To Right Side**

NOTE: This procedure is for **MINOR** adjustment in full forward travel only. Steering neutral setting must be correctly adjusted before this procedure. Early S/N loaders do not have this adjustment.

1. Loosen the bolts at the stop (Item 1) [A] and lower the lever stops (both sides).
2. Start the engine.

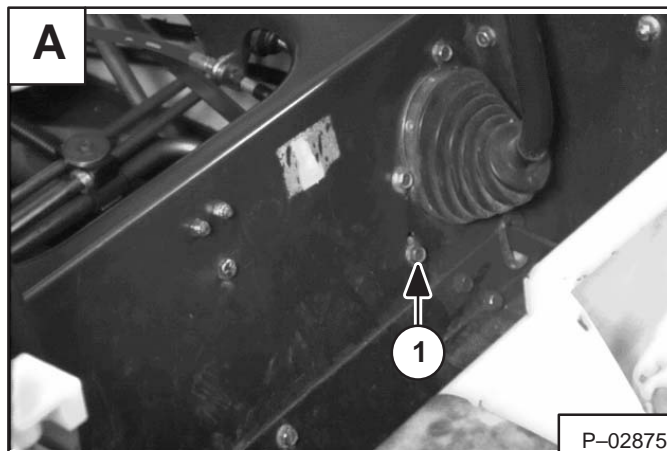
**WARNING**

Put jackstands under the front axles and rear corners of the frame before running the engine for service. Failure to use jackstands can allow the machine to fall or move and cause injury or death.

W-2017-0286

3. Check wheel RPM left and right side [B]. They should be the same. If not, the stop (Item 1) [A] can be used for MINOR adjustment. Bring the stop up on the faster side until RPM is equal. (Tighten stop before re-checking) tighten remaining side in down position.

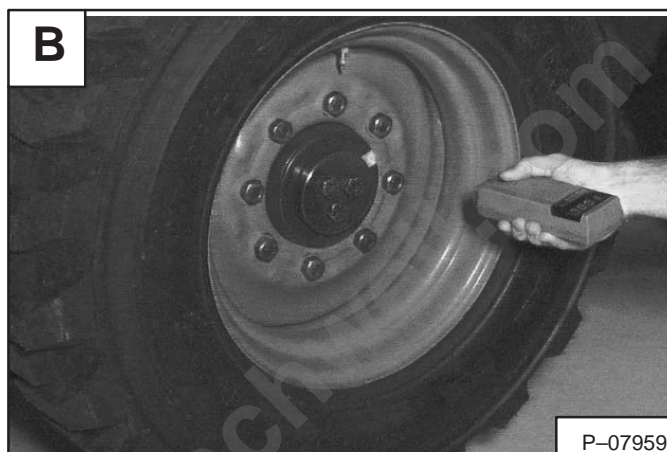

STEERING LEVERS (Cont'd)

Hydrostatic Pump Neutral Adjustment

WARNING

When working on the left side of the hydrostatic pump, Be Careful to keep your fingers and tools clear of the cooling fan belt.

W-2185-0395

After the hydrostatic pump has been rebuilt, the neutral for the servo valve spool will have to be adjusted. Use the following procedure:

NOTE: The hydrostatic pump must be installed in the loader for this procedure.

WARNING

Never work on a machine with the lift arms up unless the lift arms are secured by an approved lift arm support device. Failure to use an approved lift arm support device can allow the lift arms or attachment to fall and cause injury or death.

W-2059-0598

The following tool will be needed to do the following procedure:

MEL1429A – Remote Start Switch

Lift and block the loader. (See Page 1–1.)

Raise the operator cab. (See Page 1–1.)

Connect the remote start switch. (See Page 1–1.)

1. Block the neutral spring bracket out with a large socket (1–1/8 inch) so you can feel and see the linkage neutral setting [A] & [B].

The pump neutral adjustment bracket (Item 1) [C] controls the position of the spool lever arm (Item 2) [C] with a centering spring (Item 1) [D].

Inspect centering spring ends for damage or wear. Replace the spring if there is excessive freeplay between spool lever arm (Item 2) [C] and spring ends (Item 1) [D].

2. Loosen the bolt (Item 2) [D] for the neutral adjustment bracket.

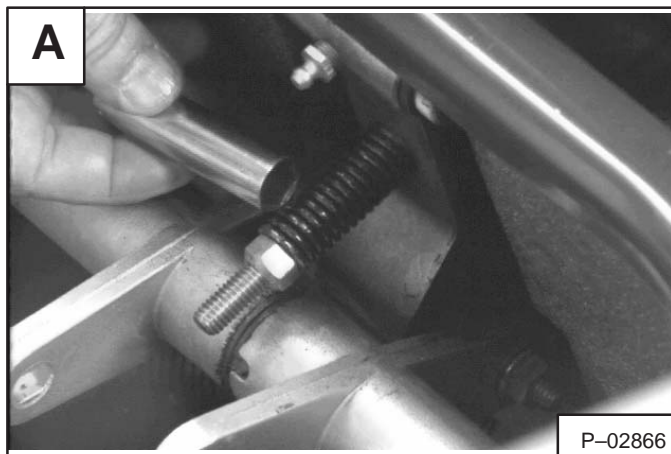

P-02866

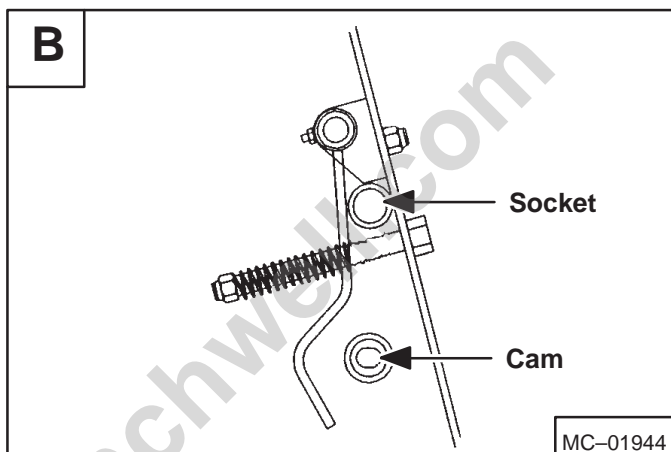

MC-01944

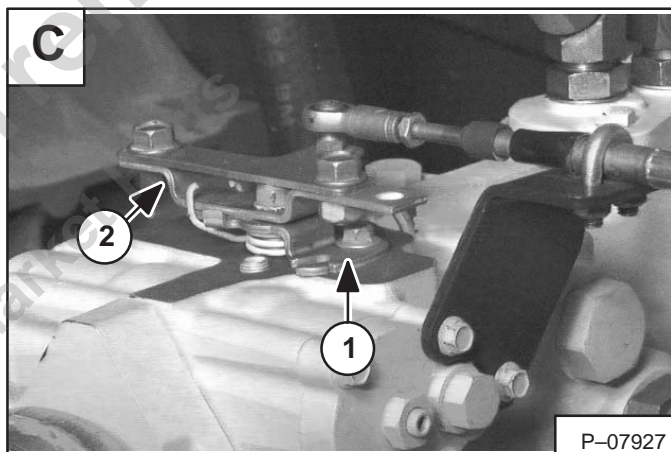

P-07927

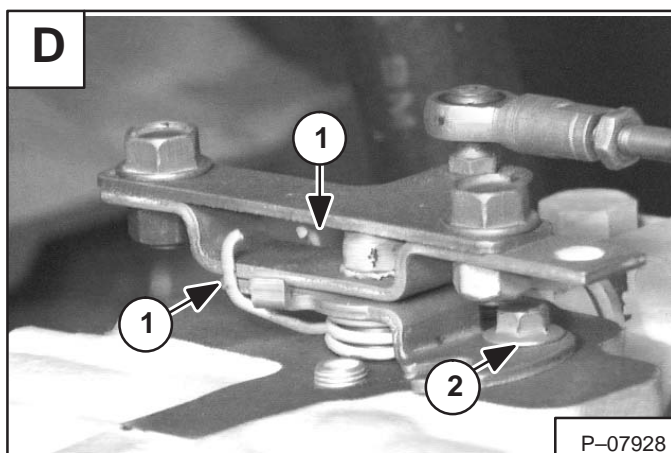

P-07928

STEERING LEVERS (Cont'd)**Hydrostatic Pump Neutral Adjustment (Cont'd)**

3. Clamp the control lever to the neutral adjustment bracket with a small locking pliers **[A]**.

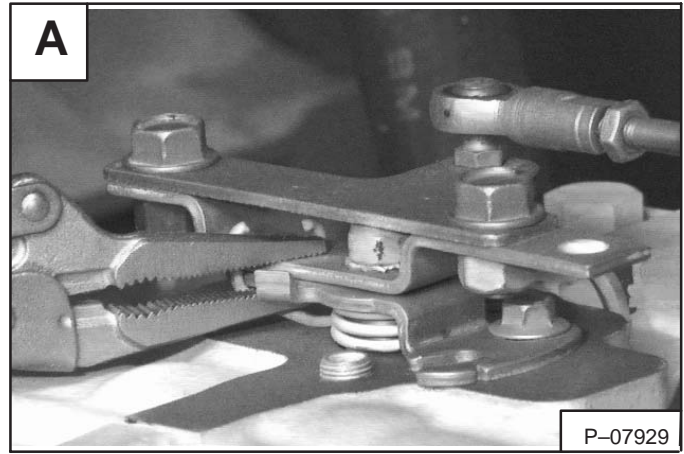

4. Start the engine. With the engine running at full RPM, move the control lever forward until the wheels just begin to move. Mark the position on the bracket (felt tip pen) **[B]**.
5. Move the control lever in reverse until the wheels just begin to move. Mark this position.
6. Stop the engine.



7. Position the neutral adjustment bracket between the two marks and tighten the hold-down bolt **[C]**. Remove the locking pliers. Start the engine and check in both directions to be sure the pump will return to neutral.



8. Remove the socket from blocking the neutral spring bracket **[D]**.
9. Adjust the steering neutral setting. (See Page 3-12.)

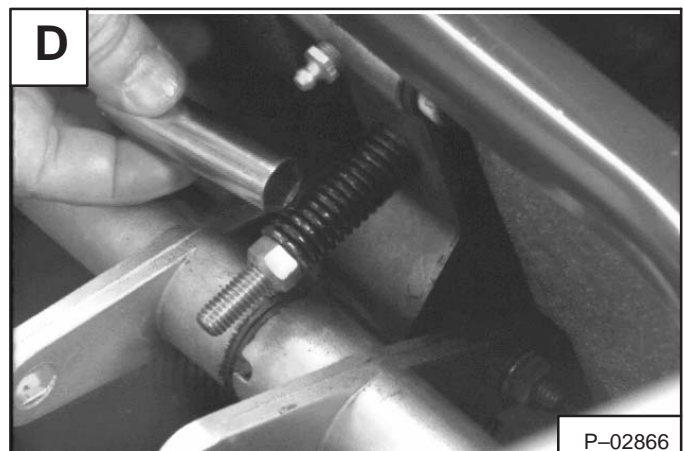

HYDROSTATIC MOTOR

Removal And Installation

IMPORTANT

When making repairs on hydrostatic and hydraulic systems, clean the work area before disassembly and keep all parts clean. Always use caps and plugs on hoses, tubelines and ports to keep dirt out. Dirt can quickly damage the system.

I-2003-0284

! WARNING

Never work on a machine with the lift arms up unless the lift arms are secured by an approved lift arm support device. Failure to use an approved lift arm support device can allow the lift arms or attachment to fall and cause injury or death.

W-2059-0598

Lift and block the loader. (See Page 1-1.)

Raise the operator cab. (See Page 1-1.)

Remove the front tire/wheel assembly.

Remove the four mounting bolts for the motor cover (Item 1) [A].

Remove the motor cover.

Mark the hoses for correct installation.

Disconnect the case drain hose (Item 1) [B].

Disconnect the high pressure hoses (Item 2) [B].

Remove the four mounting bolts (Item 1) [C] from the motor.

Installation: Tighten the bolts to 65-70 ft.-lbs. (88-95 Nm) torque.

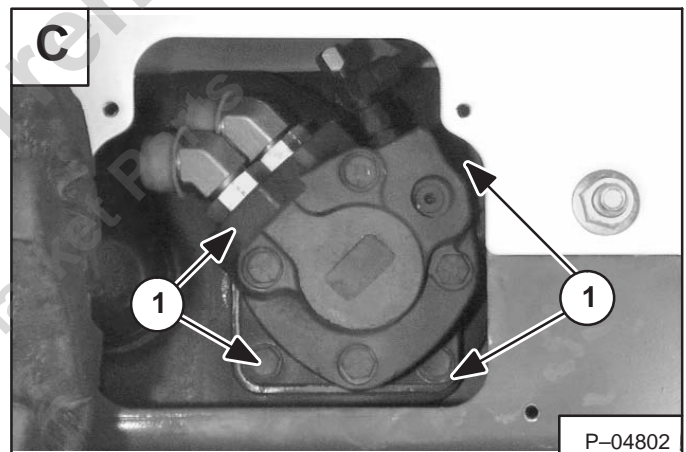
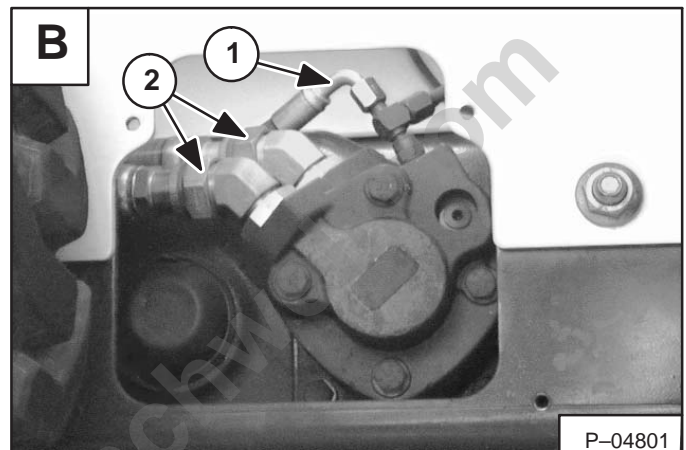
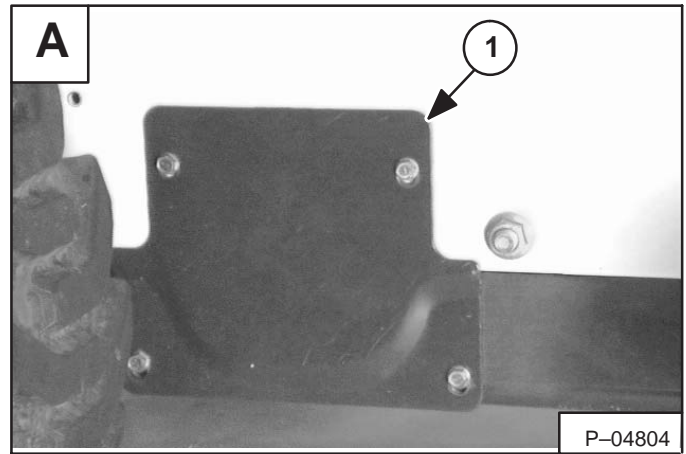

HYDROSTATIC MOTOR (Cont'd)

Removal And Installation (Cont'd)

Remove the hydrostatic motor from the gearcase.

Installation: Replace the large O-ring (Item 1) [A] and face seals on the motor fittings before installing the motor. Inspect and clean or replace case drain filters (Item 1) [B] & [C] during motor repair or replacement.

NOTE: The case drain filters were added at (S/N 510125001 & Above), (S/N 510250001 & Above) and (S/N 510370001 & Above) on the loaders.

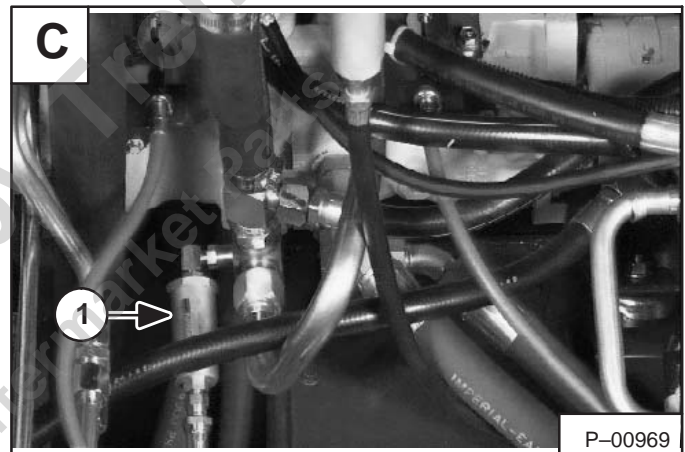
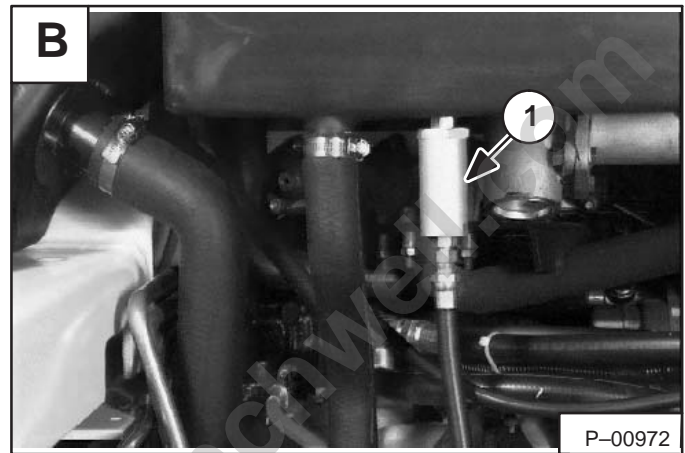
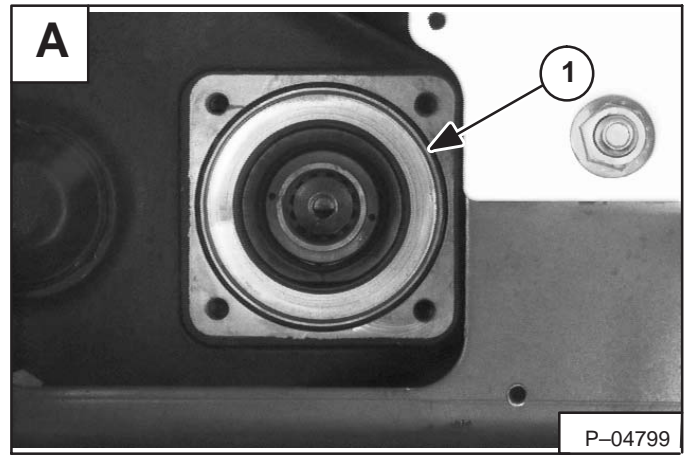

SEE THE COMPONENT REPAIR MANUAL FOR HYDROSTATIC MOTORS FOR DISASSEMBLY AND ASSEMBLY PROCEDURE.

HYDROSTATIC CHARGE OIL FILTER

Removal And Installation

 **WARNING**

Never work on a machine with the lift arms up unless the lift arms are secured by an approved lift arm support device. Failure to use an approved lift arm support device can allow the lift arms or attachment to fall and cause injury or death.

W-2059-0598

 **DANGER**
AVOID DEATH

- Disconnecting or loosening any hydraulic tubeline, hose, fitting, component or a part failure can cause lift arms to drop.
- Keep out of this area when lift arms are raised unless supported by an approved lift arm support. Replace if damaged. 531 45

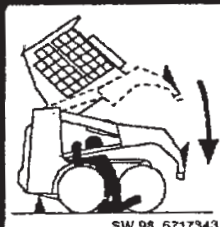

SW 98 6717343

Disconnect the temperature switch wire from the hydrostatic filter [A].

Disconnect the differential pressure switch wire from the filter [B].

Remove the inlet tubeline from the hydrostatic filter [C].

Disconnect the charge pump inlet hose from the filter [D].

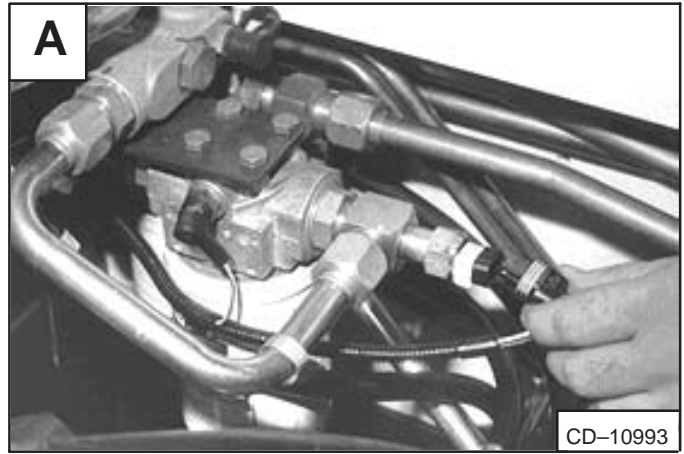

CD-10993

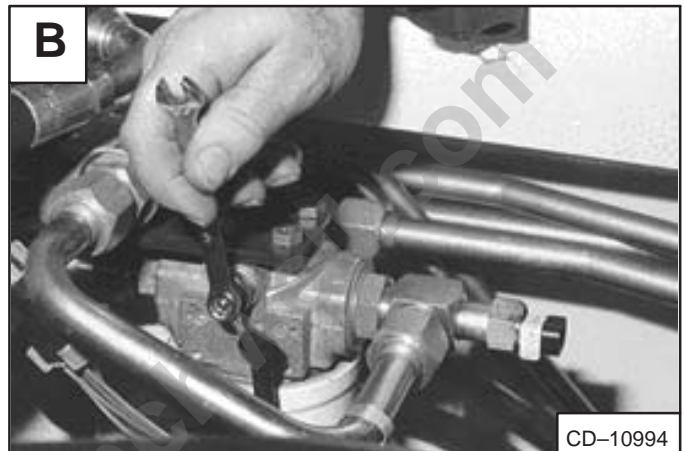

CD-10994

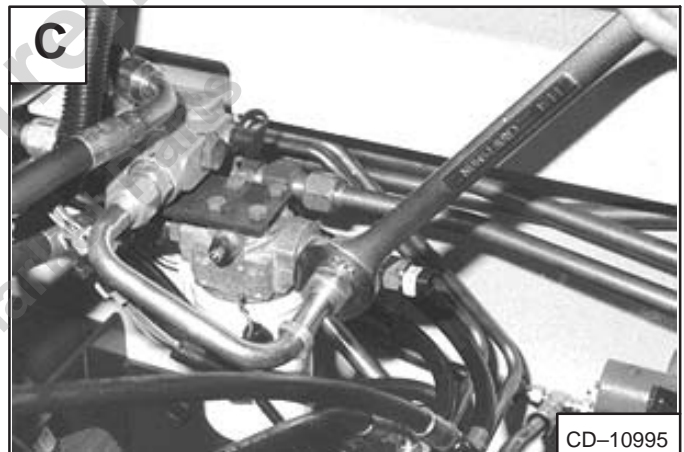

CD-10995



CD-10996

HYDROSTATIC CHARGE OIL FILTER (Cont'd)

Removal And Installation (Cont'd)

Remove the four mounting bolts [A].

Installation: Tighten the mounting bolts to 25 ft.-lbs. (34 Nm) torque.



Remove the hydrostatic filter and housing [B].

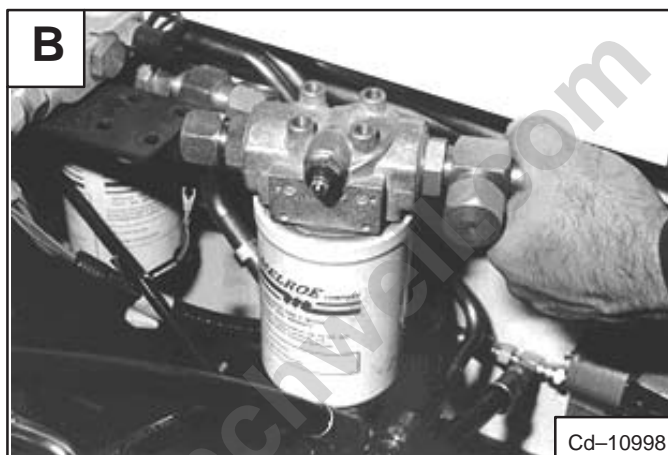

Provided for Free by Trencher.com
Shop Aftermarket Parts

COLD OIL BY-PASS VALVE**Removal And Installation**

WARNING

Never work on a machine with the lift arms up unless the lift arms are secured by an approved lift arm support device. Failure to use an approved lift arm support device can allow the lift arms or attachment to fall and cause injury or death.

W-2059-0598

DANGER
AVOID DEATH

- Disconnecting or loosening any hydraulic tubeline, hose, fitting, component or a part failure can cause lift arms to drop.
- Keep out of this area when lift arms are raised unless supported by an approved lift arm support. Replace if damaged.

531 45

6W 98 6717343

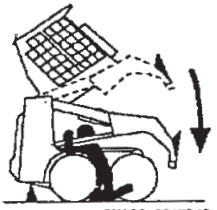

Remove the cold oil by-pass valve plug, spring and poppet to check for damage [A].

Replace the plug, spring and poppet if necessary.

Disconnect the cold oil by-pass valve outlet tubeline [B].

Disconnect the charge pump outlet hose from the tee on the by-pass valve [C].

Disconnect the oil cooler inlet tubeline from the tee fitting [D].

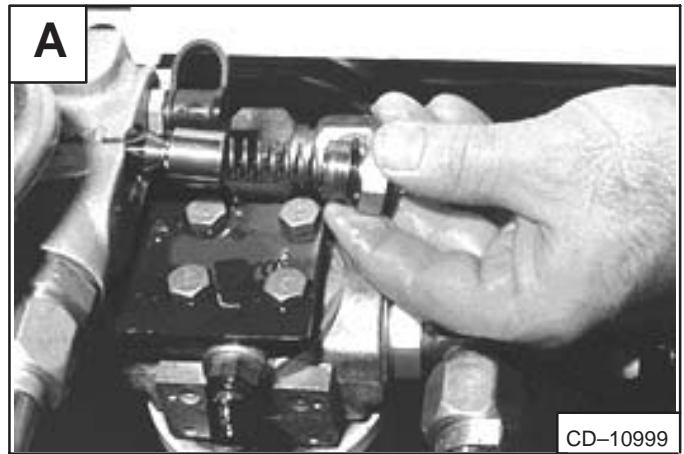

CD-10999

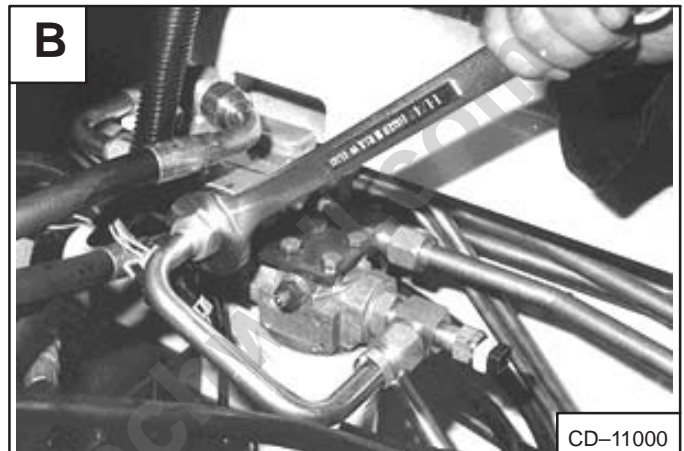

CD-11000

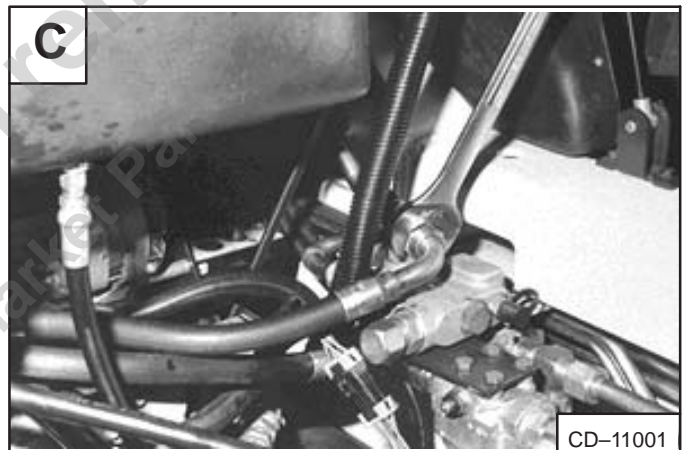

CD-11001

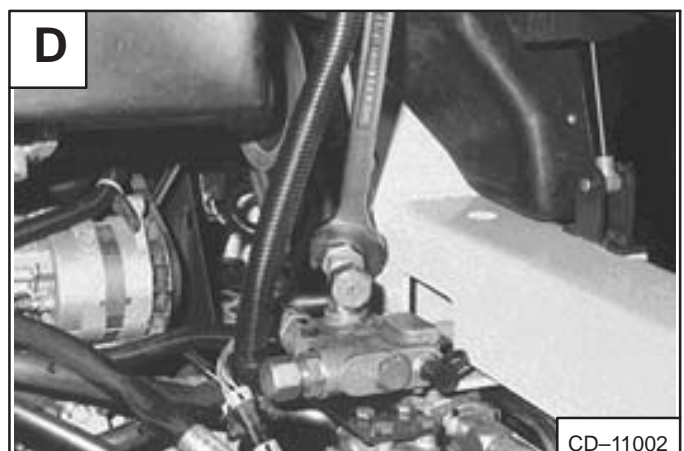

CD-11002

COLD OIL BY-PASS VALVE (Cont'd)

Removal And Installation (Cont'd)

Disconnect the oil cooler outlet tubeline (shown) and the front auxiliary valve charge hose (not shown) from by-pass valve [A].

NOTE: The auxiliary valve charge hose is next to the oil cooler outlet tubeline on the by-pass valve. The (S/N 5101) loader without front auxiliary hydraulics does not have the auxiliary valve charge hose.

Remove the by-pass valve mounting bolt and remove the valve [B].

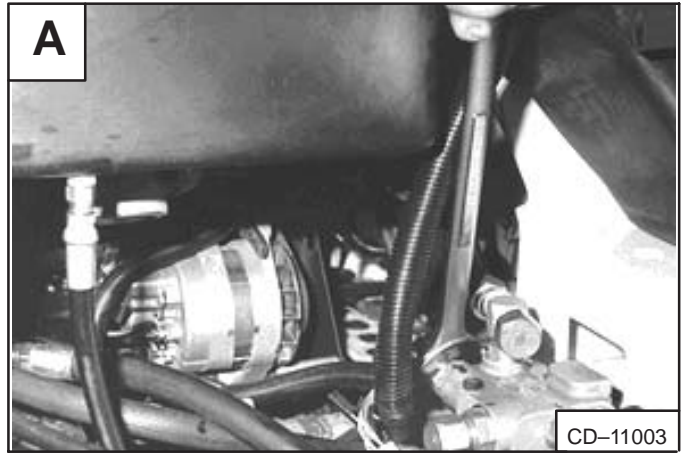

Provided for Free by Trendwe.com
Shop Aftermarket Parts

HYDROSTATIC PUMP**Removal And Installation**

Remove the hydrostatic pump/engine assembly from the loader. (See Page 7-1.)

Remove the belt shield clips (Item 1) **[A]** and belt shield (Item 2) **[A]**.

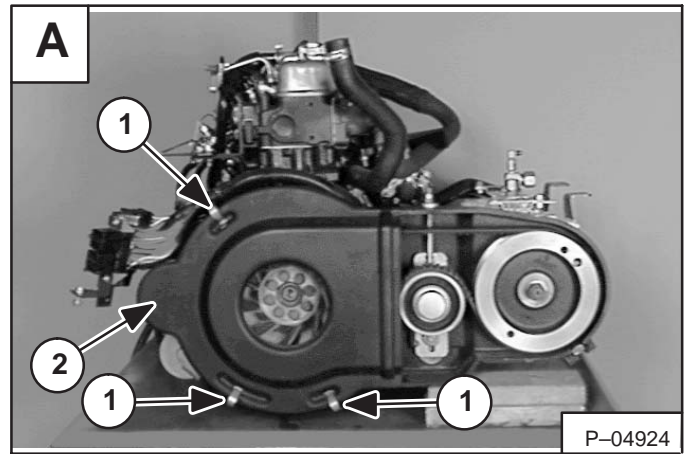

Loosen the tensioner pulley nut (Item 1) **[B]**.

Remove the drive belt (Item 2) **[B]**.

Installation: Tighten the drive belt to the correct specifications. (See Page 3-32 or 3-41.)

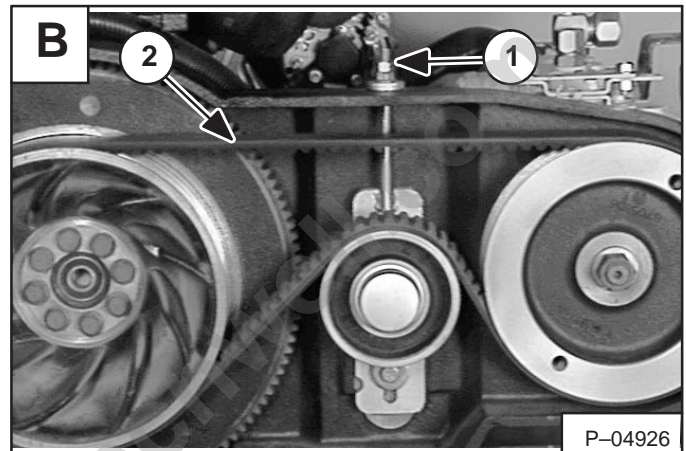

Remove the washer and nut (Item 1) **[C]** from the hydrostatic pump drive shaft.

Installation: Tighten the nut to 175-200 ft.-lbs. (237-271 Nm) torque.

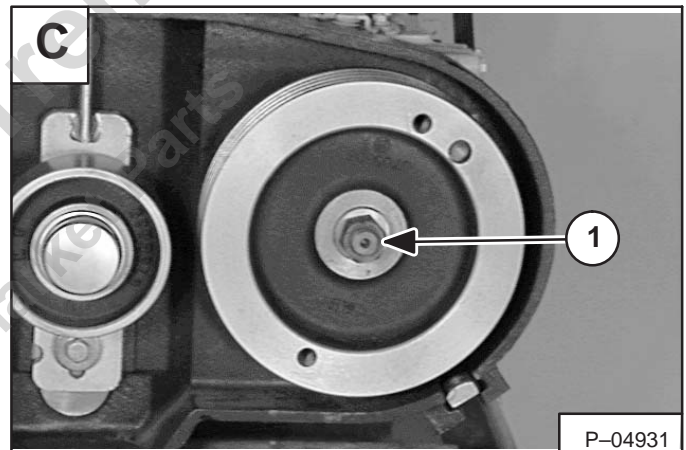

Install the nut on the end of the pump drive shaft (without washer).

Use a puller (Item 1) **[D]** to remove the pulley from the pump drive shaft.

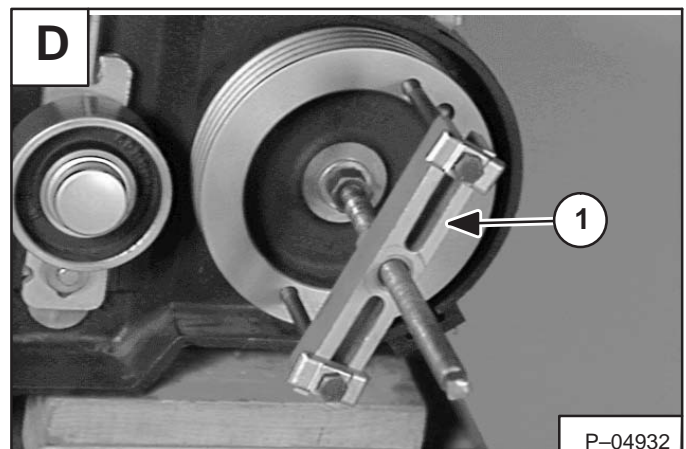

HYDROSTATIC PUMP (Cont'd)**Removal And Installation (Cont'd)**

Remove the two mounting bolts (Item 1) [A] and nuts (Item 1) [B].

Installation: Tighten the mounting bolts and nuts to 65–70 ft.-lbs. (88–95 Nm) torque. Make sure the key (Item 2) [A] is installed.

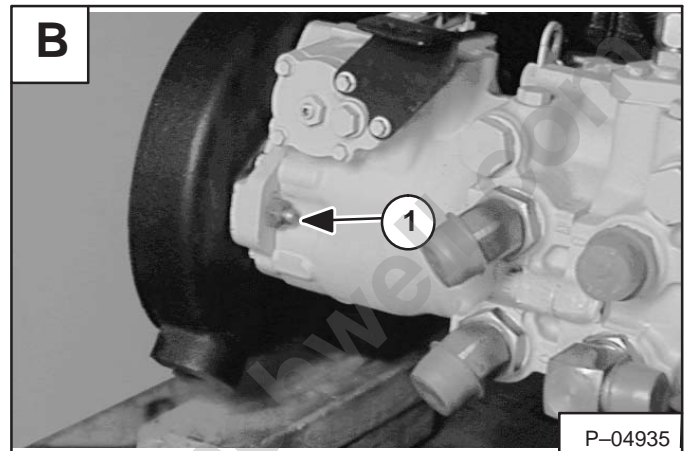
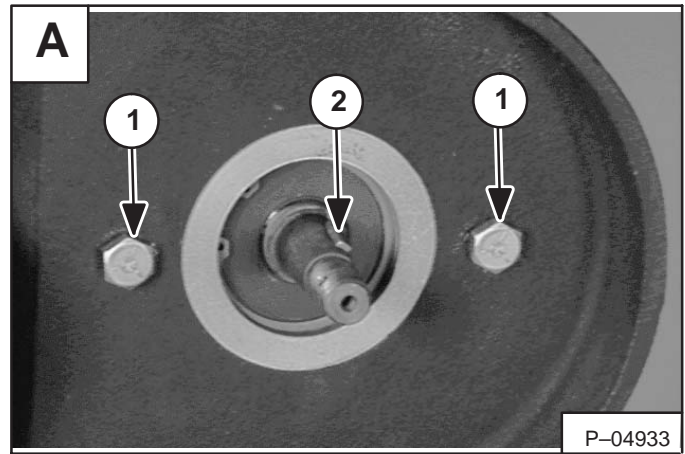

Remove the mounting bolt (Item 1) [C] at the hydraulic pump end of the pump.

Remove the hydrostatic pump from the mounting bracket and drive belt housing.

SEE THE COMPONENT REPAIR MANUAL FOR HYDROSTATIC PUMPS FOR DISASSEMBLY AND ASSEMBLY PROCEDURE.

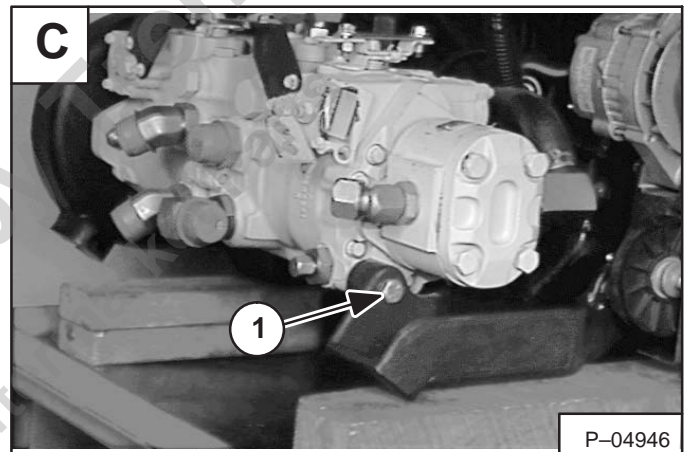

HYDROSTATIC PUMP (Cont'd)**Replenishing/High Pressure Relief Valve**

There are four replenishing/high pressure relief valves (Item 1) [A] in the hydrostatic pump. Two are located at the front of the pump and two at the rear of the pump.

See Page 3–4 for valve function.

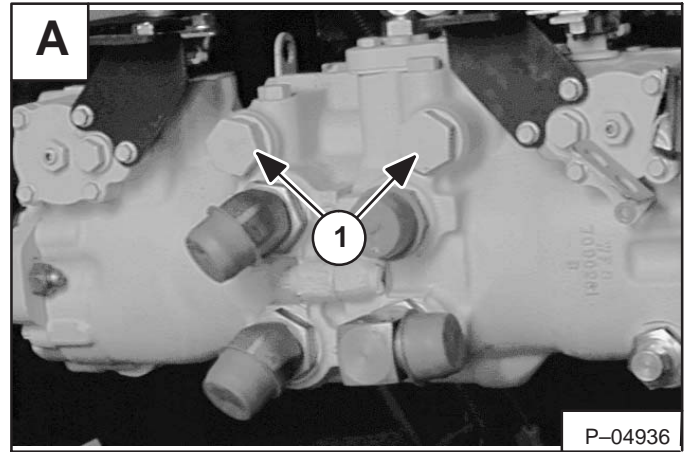

P-04936

Remove the plug spring and high pressure relief valve from the pump [B].

Check for damage and replace as needed.

Ref.	Description
1.	PLUG
2.	O-RING
3.	SPRING
4.	HIGH PRESSURE RELIEF

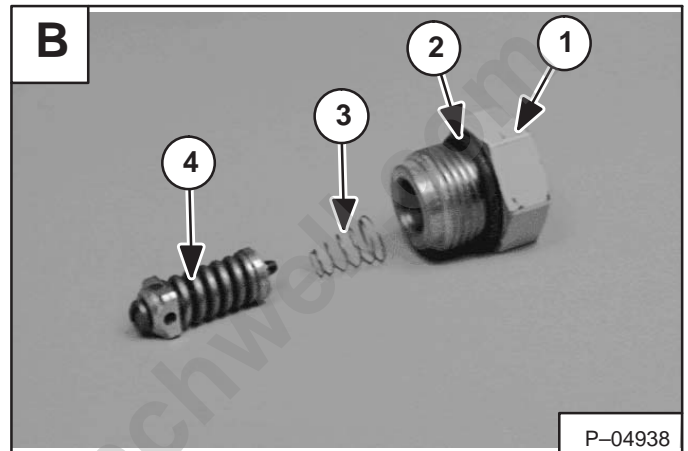

P-04938

Provided for Free by Trenchwell
Shop Aftermarket Parts

DRIVE BELT SHIELD

Removal And Installation

Stop the engine.

Open the rear door.

Remove the three belt shield holddown clips (Item 1) [A].

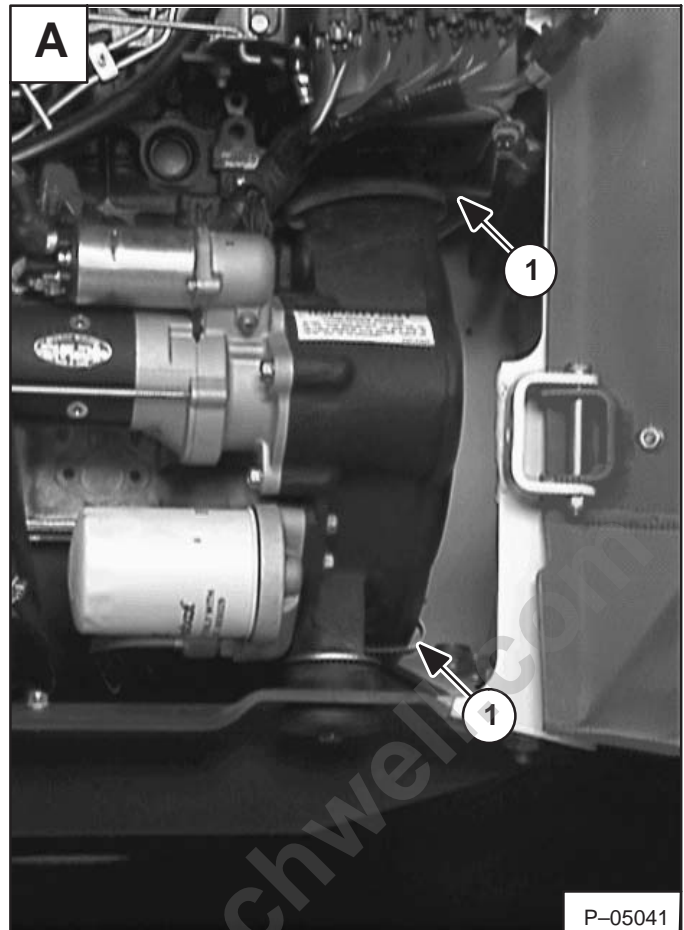

Remove the belt shield (Item 1) [B] from the drive belt housing.

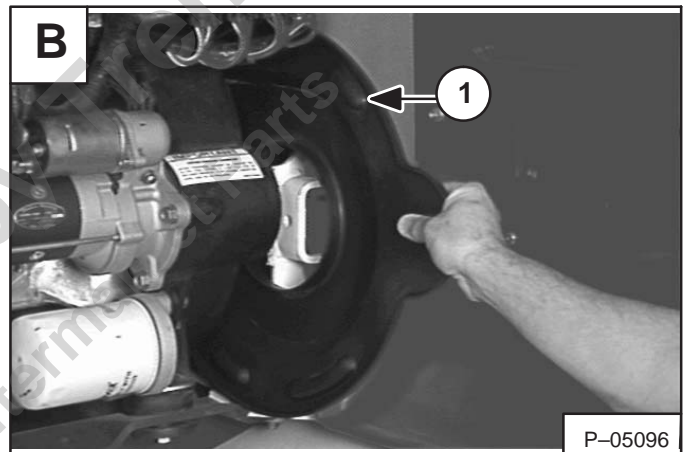

DRIVE BELT**Replacing The Drive Belt**

Raise the operator cab. (See Page 1–1.)

Remove the belt shield. (See Page 3–26.)

Loosen the bolt (Item 1) **[A]** on the idler pulley tensioner mounting bracket.

Loosen the jam nut (Item 2) **[A]** and turn the nut (Item 3) **[A]** to release the belt tension.

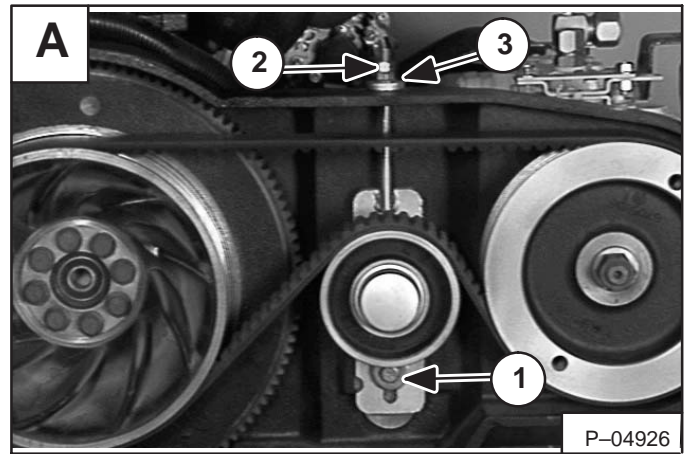

Remove the drive belt from the hydrostatic pump pulley and flywheel pulley.

Remove the drive belt **[B]**.

Installation: Install the new drive belt and adjust. (See Page 3–32 or 3–41.)



Provided for Free by Trend
Shop Aftermarket Parts

SPRING LOADED TENSIONER PULLEY

Parts Identification

1. Cover
2. Bolt
3. Washer
4. Pins
5. Washer
6. Spring
7. Snap Ring
8. Snap Ring
9. Bearing
10. Dust Shield
11. Pulley
12. Bushing
13. Hub
14. Washer
15. Seal
16. Arrow Indicator Plate
17. Locating Pin
18. Spring
19. Shaft
20. Bracket

NOTE: Drive idler parts are not available individually. Consult parts catalog for available sub-assemblies.

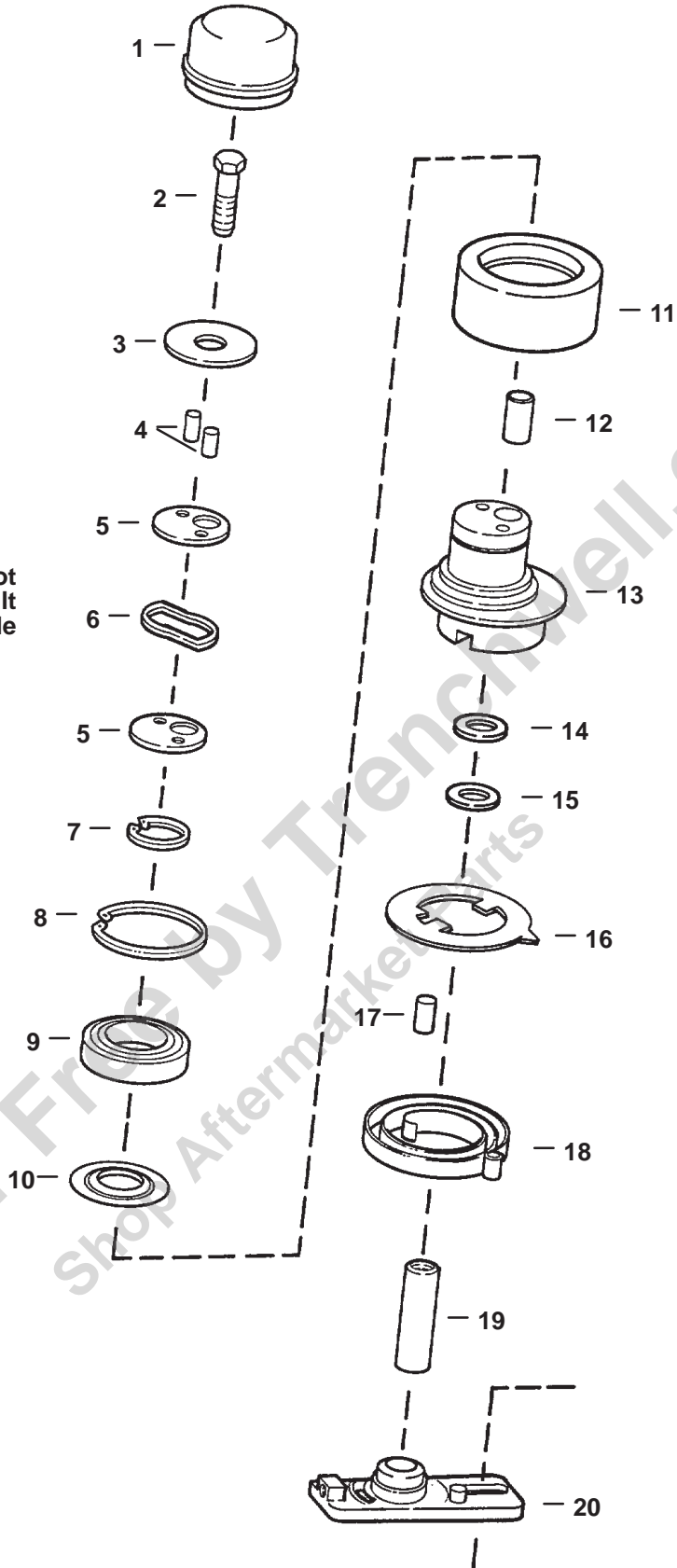

E-02296

SPRING LOADED TENSIONER PULLEY (Cont'd)**Disassembly**

Remove the grease cover (Item 1) [A].

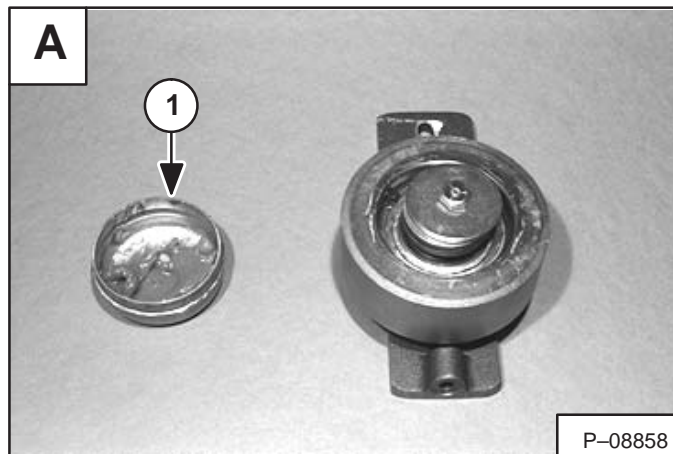

Remove the bolt (Item 1) [B], the flat washer (Item 2) [B], the retainer washer (Item 3) [B], the spring washer (Item 4) [B] and the second retainer washer (Item 3) [B] from the pulley assembly (Item 5) [B].

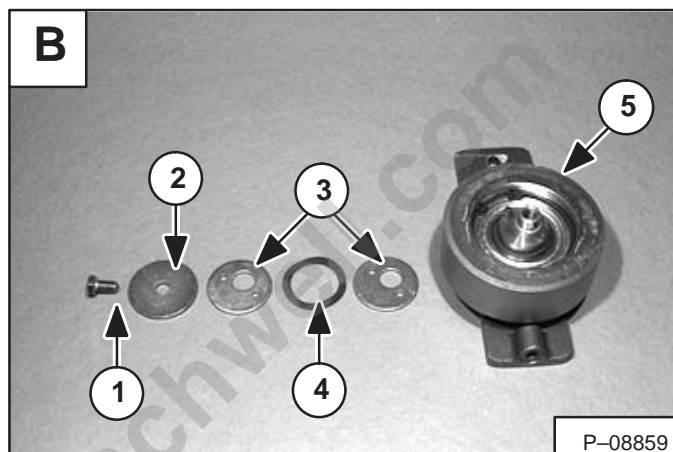

Remove the two pins (Item 1) [C] from the hub assembly (Item 2) [C] only if they have been damaged.

Remove the bracket assembly (Item 3) [C] by tapping on the shaft (Item 4) [C] with a plastic hammer.

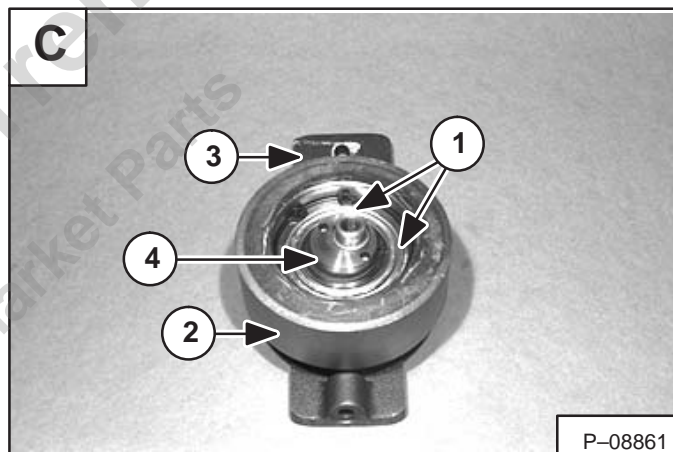

Remove the spring (Item 1) [D] from the bracket (Item 2) [D].

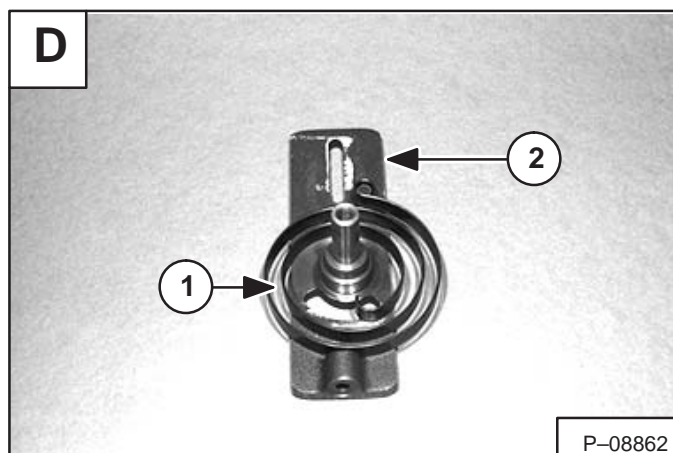

SPRING LOADED TENSIONER PULLEY (Cont'd)**Assembly**

Install the spring (Item 1) [A] on the pulley (Item 2) [A] as shown.

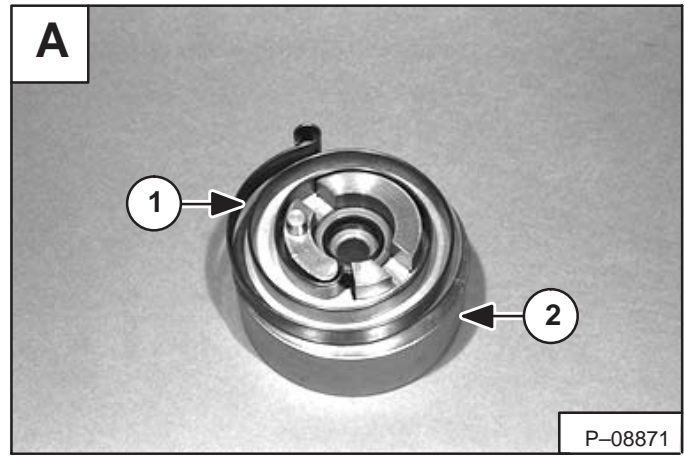

Install the shaft from the bracket assembly (Item 1) [B] into the pulley assembly (Item 2) [B] and align the spring (Item 3) [B] over the alignment pin on the bracket.

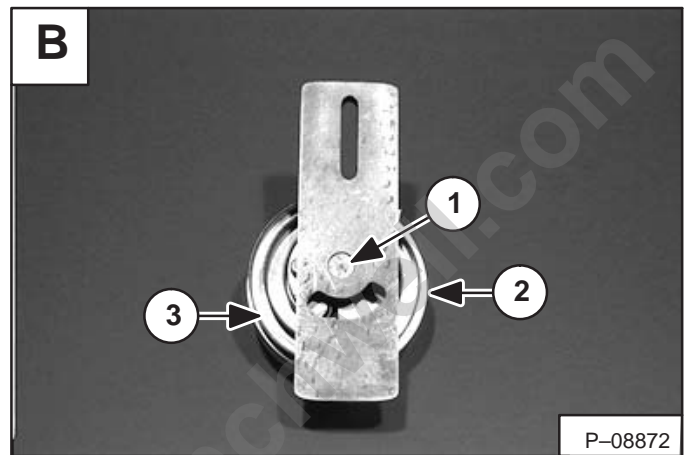

Turn the pulley assembly over and install the two pins (Item 1) [C] into the hub.

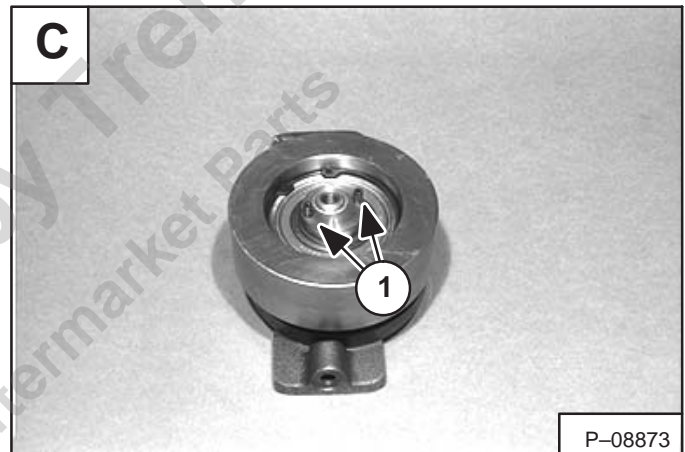

Install a punch as shown and turn clockwise while applying down pressure on the pulley.

Turn until the pulley snaps down into place; this procedure winds the spring and retains the end of the spring in proper location [D].

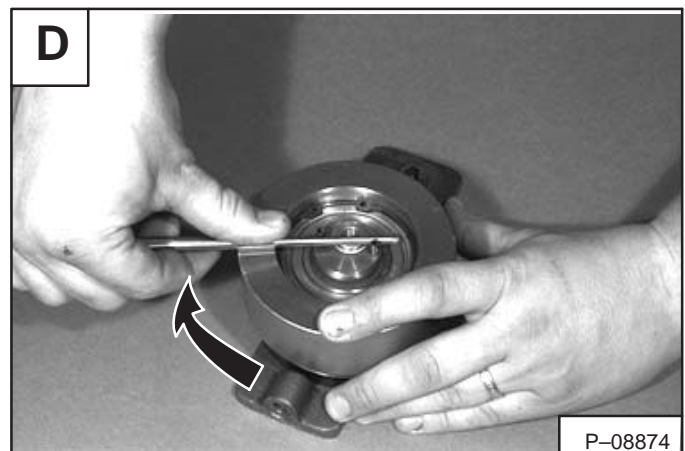

SPRING LOADED DRIVE BELT TENSIONER PULLEY (Cont'd)

Assembly (Cont'd)

Install the first retainer washer (Item 1) [A] and spring washer (Item 2) [A] over the roll pins.

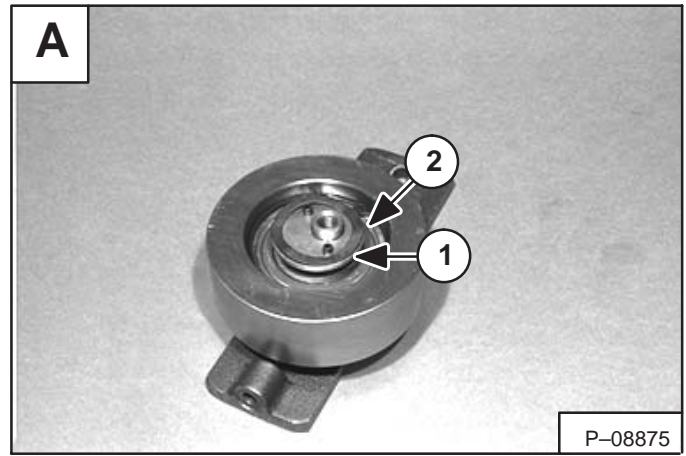

Install the second retainer washer (Item 1) [B], the washer (Item 2) [B] and the bolt (Item 3) [B]. Tighten the bolt to 28–32 ft.-lbs. (38–45 Nm) torque.

Fill the grease cap 1/4 full (approximately 1/2–3/4 oz.) of grease.

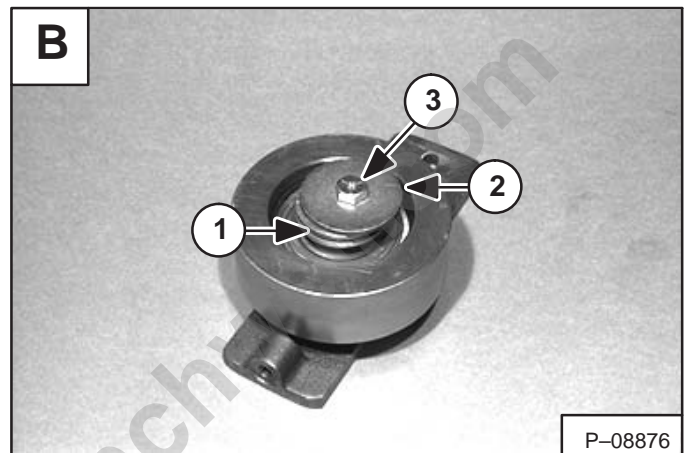

Press the grease cap (Item 1) [C] onto the pulley assembly (Item 2) [C]. Press on the outer formed edge of the grease cap.

NOTE: When pressing the grease cap onto the pulley assembly, do not press down on the arrow indicator plate. Support the hub assembly so that it contacts only the hub and not the arrow indicator plate.

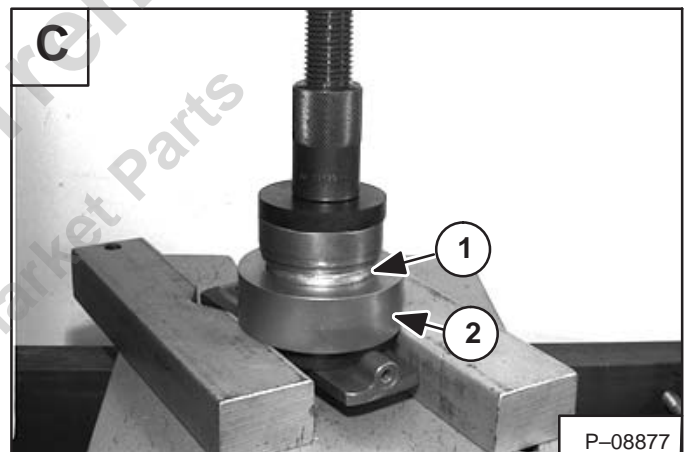

SPRING LOADED TENSIONER PULLEY (Cont'd)**Adjusting The Drive Belt**

When adjusted correctly the spring loaded idler assembly will increase the service life of the drive belt.

To adjust the spring loaded tensioner pulley, use the following procedure:

Loosen the mounting bolt (Item 1) **[A]** on the idler bracket. The pointer (Item 1) **[B]** will be at the seven o'clock position when the belt tensioner is not under spring pressure.

Pull the idler pulley against the drive belt, with the adjusting nut (Item 2) **[A]**, until the pointer is at the nine o'clock position (Item 2) **[B]**, lower the idler assembly a small amount so that the idler is operating on spring tension.

Tighten the mounting bolt (Item 1) **[A]** to 25–28 ft.-lbs. (34–38 Nm) torque.

Run the engine for a few minutes. Stop the engine and check the pointer position.

Adjust the idler assembly as needed.

After the spring loaded tensioner pulley has been in service, readjust when the pointer reaches the seven o'clock position.

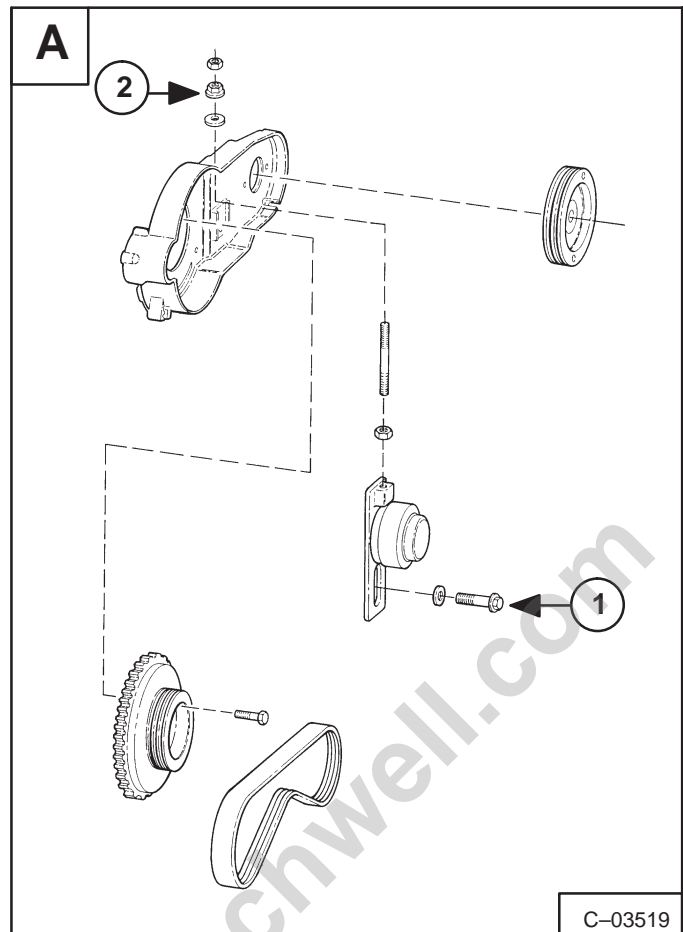

C-03519

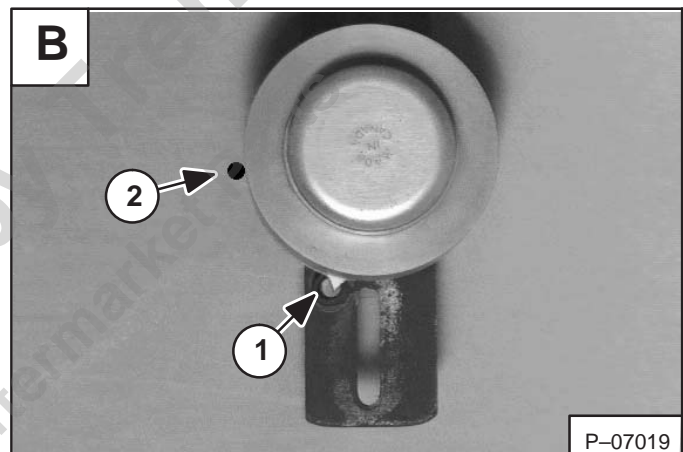

P-07019

FIXED TENSIONER PULLEY**Removal And Installation**

Remove the three belt shield holddown clips (Item 1) [A].

Remove the belt shield.

Loosen the tensioner pulley mounting bolt (Item 1) [B].

Loosen the jam nut and lock nut (Item 2) [B].

Remove the drive belt.

Installation: Tighten the drive belt to the correct specifications. (See Page 3-41.)

Remove the jam nut and lock nut (Item 1) [C].

Remove the mounting bolt (Item 2) [C].

Remove the tensioner pulley assembly.

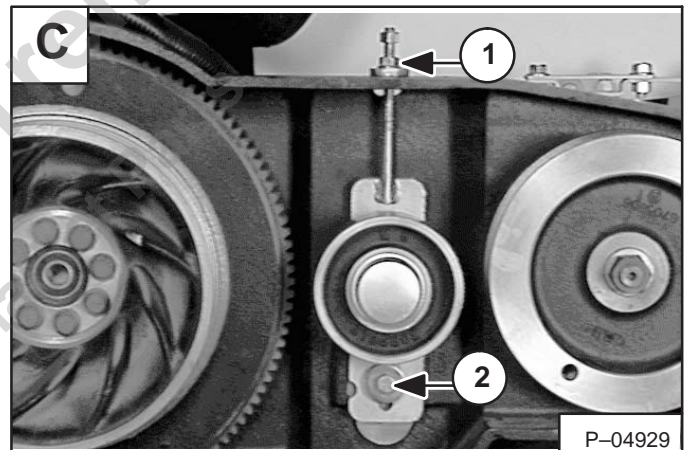
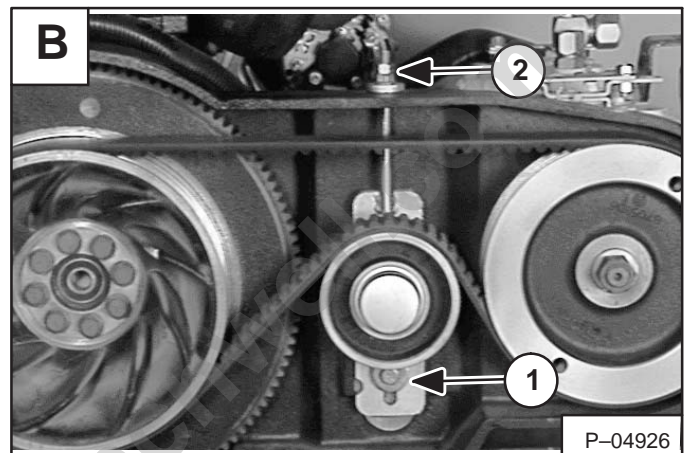
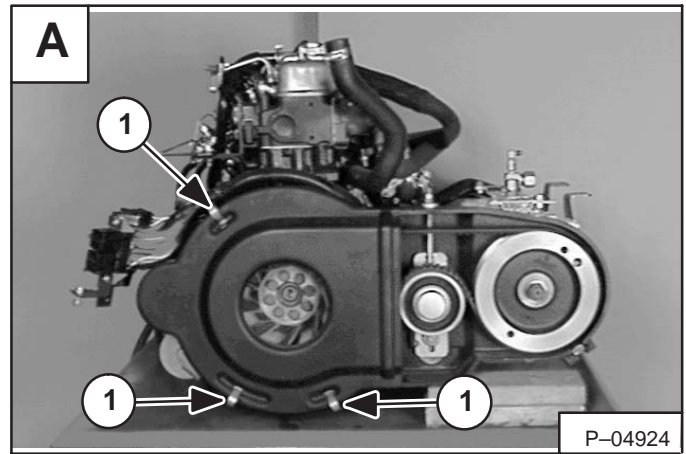

FIXED TENSIONER PULLEY (Cont'd)

Disassembly

NOTE: Be careful, the pulley hub is full of oil.

Remove the cap [A].



Remove the bolt and washer [B].



Install a long bolt into the shaft [C].



Remove the idler pulley and bearing from the shaft using a press [D].



FIXED TENSIONER PULLEY (Cont'd)

Disassembly (Cont'd)

Install a bearing puller behind the seal and wear sleeve [A].

PHOTO CLARITY ONLY: If the bearing puller is installed behind the bearing, seal and wear sleeve, the wear sleeve will also be removed [B].

Remove the bearing, seal and wear sleeve using the press [C].

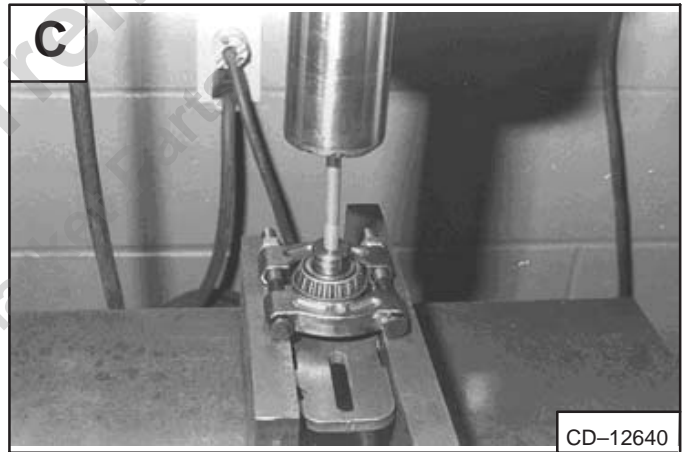
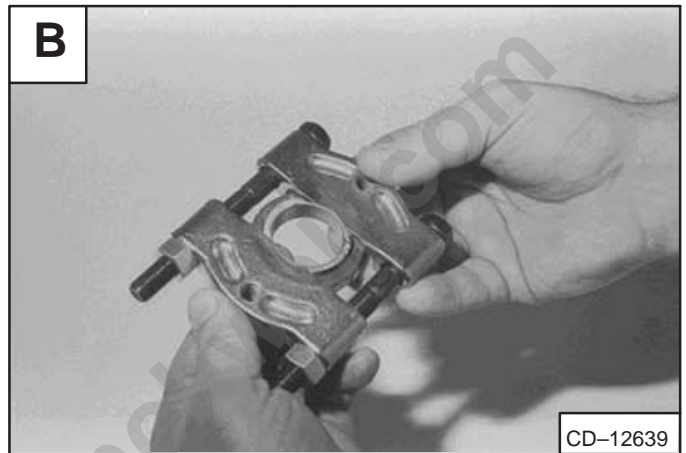
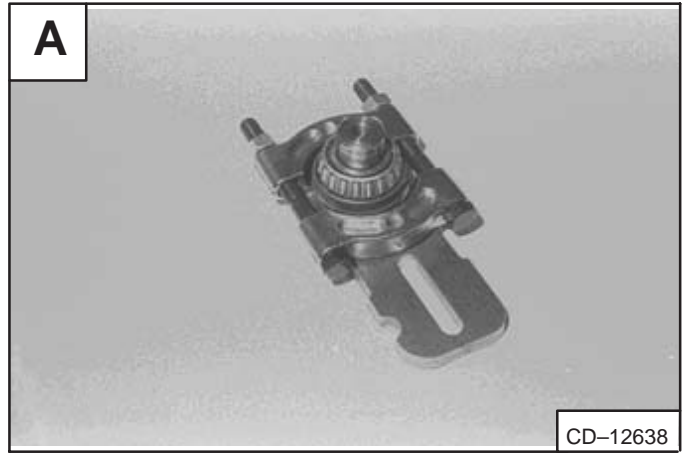

Provided for Free by www.youfixthis.com
Shop Aftermarket Parts

FIXED TENSIONER PULLEY (Cont'd)

Assembly

NOTE: The bearings, cups and spacers are a matched set and must be replaced as a unit.

If the spacer is replaced, compress the new spacer and install into the pulley [A].



Use a driver tool (1-5/16" diameter) and push the spacer into the machined groove [B].

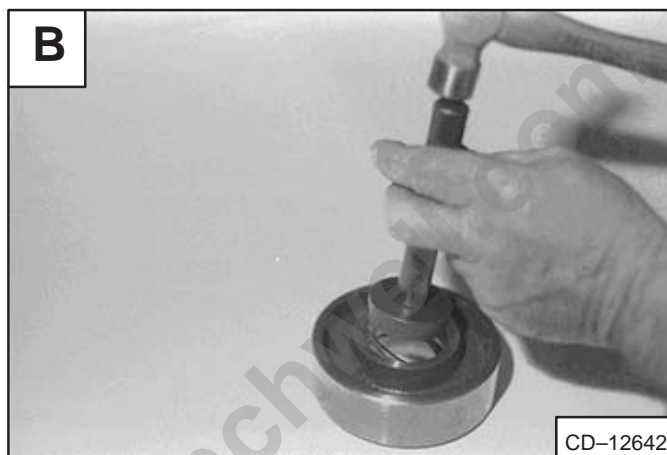

Install the bearing cup using the driver tool (both sides) [C].

NOTE: The seal side of the pulley hub has the larger I.D. diameter.



Install the taper roller bearing to the pulley (seal side) [D].



FIXED TENSIONER PULLEY (Cont'd)**Assembly (Cont'd)**

Put sealant (P/N 6633538) around the diameter of the shaft where the wear sleeve is installed [A].

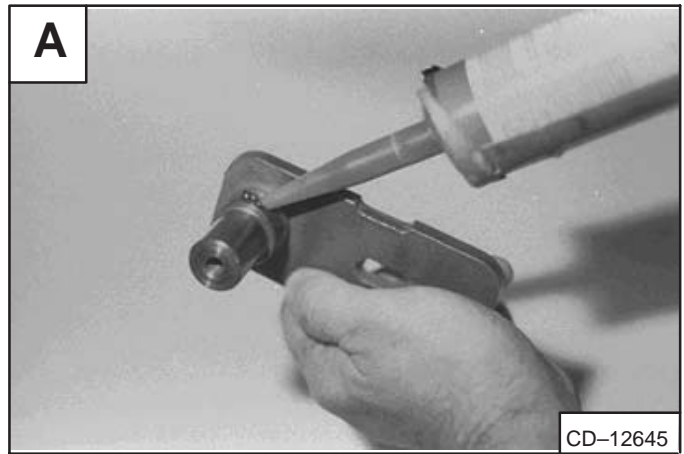

Put grease (P/N 6599719) on the seal lips (Item 1) [B]. Make sure the grease is between the outside and inside lips and all the way around the seal.

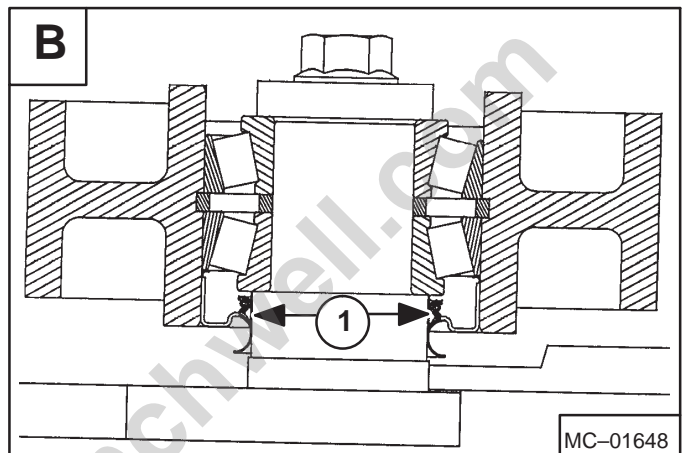

Press the seal into the pulley hub larger diameter using a press [C].

NOTE: The wear sleeve and the seal must be replaced as a unit.

DO NOT damage the seal lips with the sharp edge of the wear sleeve. Install the wear sleeve into the seal.



Use a spacer tube which goes over the shaft and pushes on the inside diameter of the taper bearing, install the pulley, seal and wear sleeve onto the shaft [D].



FIXED TENSIONER PULLEY (Cont'd)

Assembly (Cont'd)

Install the small bearing spacer [A].



Install the taper roller bearing pushing on the I.D. of the bearing [B].



Put LOCTITE (P/N 6540410) on the bolt threads [C].



Install the bolt and washer into the shaft [D].

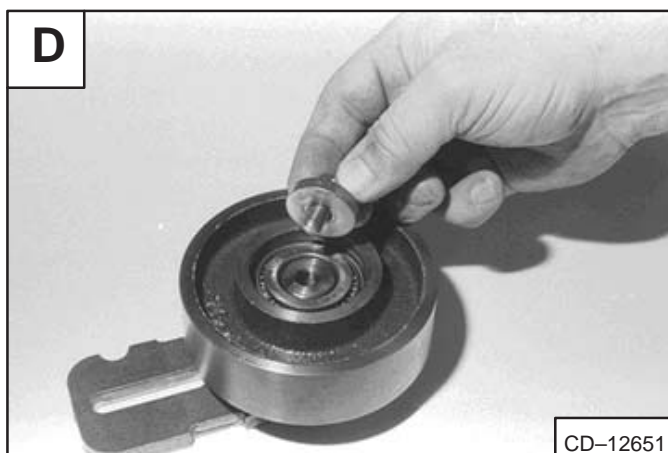

FIXED TENSIONER PULLEY (Cont'd)**Assembly (Cont'd)**

Tighten the bolt to 25–28 ft.-lbs. (43–38 Nm) torque [A].



Use only 15W/50 synthetic oil (Example: Mobil One) for the bearings. Use the cap and add oil until it is at the 0.50" (12,7 mm) mark on the scale, which should be 0.75 oz. (20 C.C.) of oil [B].

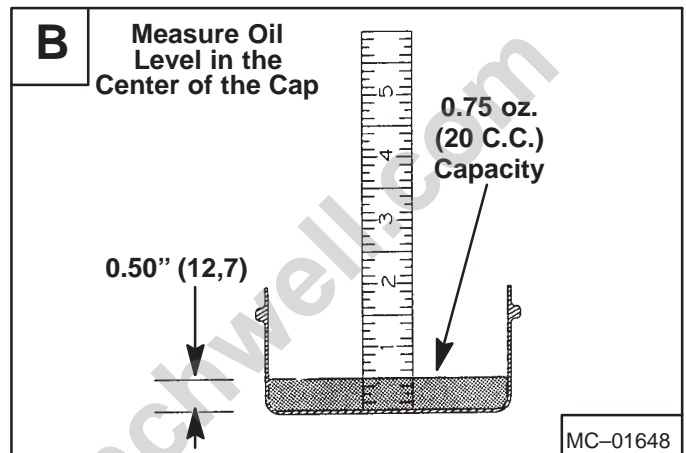

Add the oil slowly, at one location of the bearing which will allow the trapped air to escape from the other side [C].

NOTE: Oil capacity is very critical, do not add any more and/or any less oil to the idler pulley.

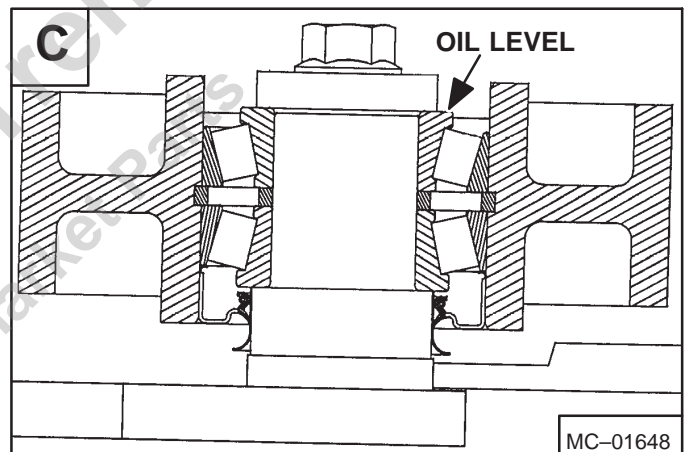

Check the cap sealing edge to make sure it is not damaged. Replace the cap as needed.

Make sure the sealing edge on the hub bore and cap sealing edge is clean and free of oil, put a bead of sealant (P/N 6633538) on the cap [D].

Install the cap.



FIXED TENSIONER PULLEY (Cont'd)

Checking Pulley End Play

Install the pulley/mounting bracket assembly in to vise.

Install a dial indicator on the pulley hub [A].

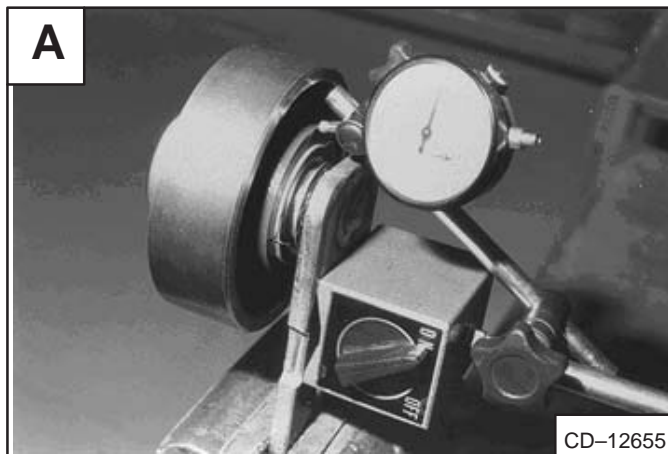

Move the pulley by hand, back and forth. The correct end play is 0.005–0.013 inch (0,13–0,33 mm) [B].

If the end play is not correct, there is no adjustment. Replace the hub, pulley and/or bearings.

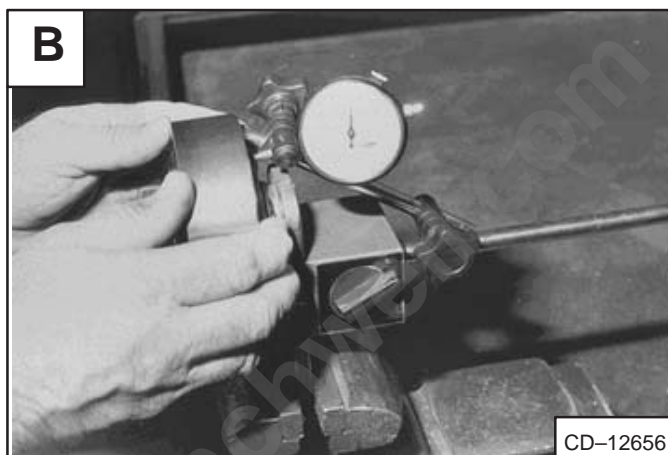

Provided for Free by Trench.com
Shop Aftermarket Parts

FIXED TENSIONER PULLEY (Cont'd)**Adjusting The Drive Belt**

See the *SERVICE SCHEDULE* Page 1-1 for the service interval.

To adjust the drive belt between the engine flywheel and the hydrostatic pump pulley, use the following procedure:

Raise the operator cab. (See Page 1-1.)

Remove the belt shield. (See Page 3-26.)

Use the following tools to check the belt tension:

MEL1404 – Bar
MEL1406 – Spring Scale

1. Install the tool on the drive belt. The pin (Item 1) [A] must be pulled tight against the engine drive pulley.
2. Make a mark (Item 2) [A] on the cast flange just above the tool handle.
3. Install the spring scale on the tool handle. The line of pull (Item 3) [A] on the spring scale must be at approximately 90° from the tool handle.
4. Loosen bolt (Item 4) [A] and jam nut (Item 5) [A].
5. Tighten adjustment nut (Item 6) [A] to increase belt tension; loosen to decrease belt tension.
6. Tighten bolt (Item 4) [A] and jam nut (Item 5) [A].

NEW BELT: (less than .5 hours use): With 14 lbs. (62 N) for force, the tool should move 1.25 inches (32,0 mm) (the width of the tool handle). Run the engine approximately 5 minutes and readjust the tension.

USED BELT: (more than .5 hours use): With 12 lbs. (52 N) of force, the tool should move 1.25 inches (32,0 mm) (the width of the tool handle).

Always readjust if a tension check results in a reading of less than 10 lbs. (44N) of force.

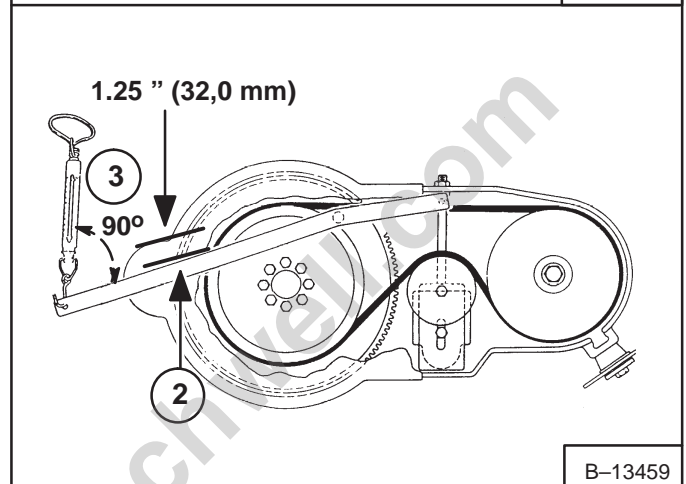
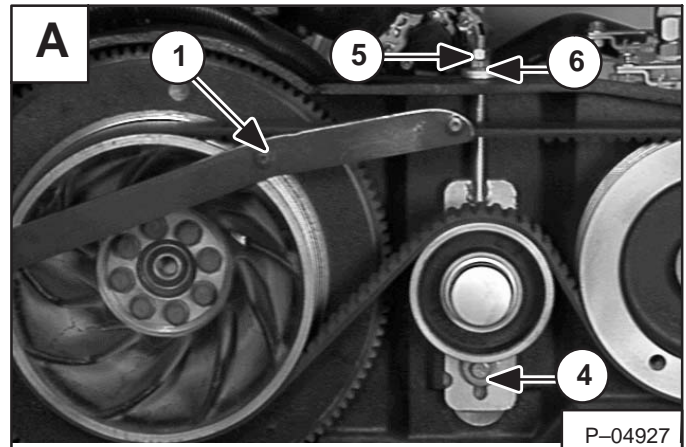

OIL COOLER

Removal And Installation

Disconnect the tubeline (Item 1) **[A]** from the oil cooler.

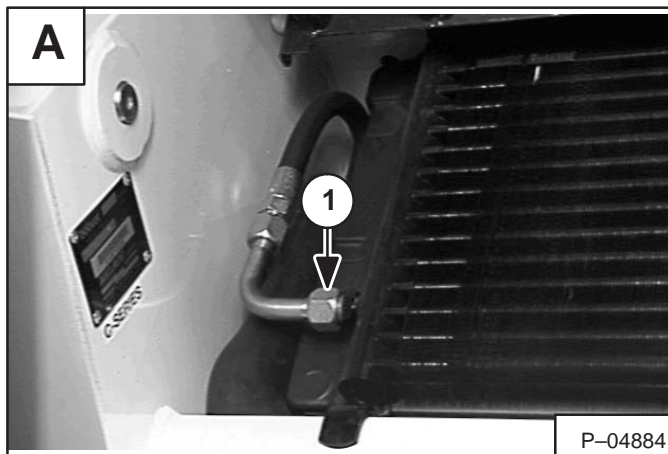

Disconnect the tubeline (Item 1) **[B]** from the oil cooler.

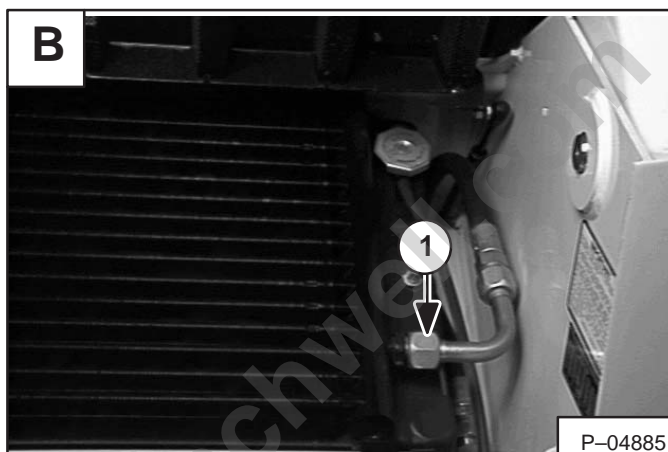

Install caps and plugs on open connections.

Remove the oil cooler **[C]**.



DRIVE SYSTEM

	Page Number
AXLE SEAL	
Removal And Installation	4-9
AXLE, SPROCKET AND BEARINGS	
Removal And Installation	4-11
CHAINCASE FLUID	
Removing The Fluid From The Chaincase	4-27
DRIVE CHAIN	
Removal And Installation	4-26
FRONT CHAINCASE COVER	
Removal And Installation	4-8
PARKING BRAKE	
Brake Block And Pads	4-6
Brake Discs	4-7
Removal And Installation	4-4
PARKING BRAKE PEDAL	
Adjustment	4-3
REAR CHAINCASE COVER	
Removal And Installation	4-8
REDUCTION GEARCASE	
Assembly	4-22
Checking Reduction Gearcase	4-17
Disassembly	4-17
Reduction Gearcase Seal	4-15
Removal And Installation	4-15

**DRIVE
SYSTEM**



bobcat[®]

Provided for Free by [franchwell.com](http://www.franchwell.com)
Shop Aftermarket Parts

PARKING BRAKE PEDAL

Adjustment

When the parking brake is in good condition and adjusted correctly, it will keep the loader from moving when the steering levers are moved.

Raise the operator cab. (See Page 1-1.)

Loosen the lock nut and turn the nut (Item 1) **[A]** to adjust the parking brake linkage.

With the brake released, lift the pedal to remove linkage end play.

Adjust the pedal so there is 2.0 inch (51 mm) from the top of the pedal to the top of the chaincase cover **[B]**.

Tighten the lock nut against the adjustment nut when the adjustment is correct.

NOTE: If the correct brake adjustment can not be obtained by turning the nut, the brake lever must be adjusted using the following procedure.

Loosen the nut (Item 1) **[A]**.

Disconnect the spring (Item 1) **[C]** from the brake lever.

Loosen the bolt (Item 2) **[C]** on the brake lever. Do not remove the bolt.

Use a pry bar and hammer, pry up on the lever and hit the bolt with a hammer until the brake lever is loose **[D]**.

Remove the bolt and brake lever.

Turn the brake block shaft counterclockwise until the brake pads make contact with the brake discs.

Install the brake lever. Install the bolt and tighten to 65–70 ft.-lbs. (88–95 Nm) torque.

Re-adjust the parking brake.

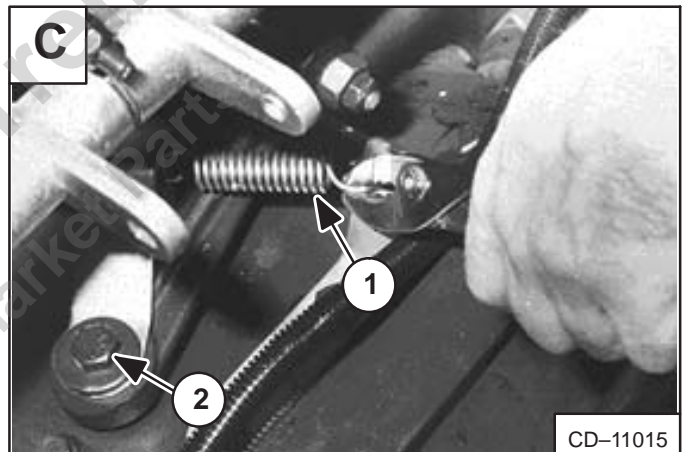
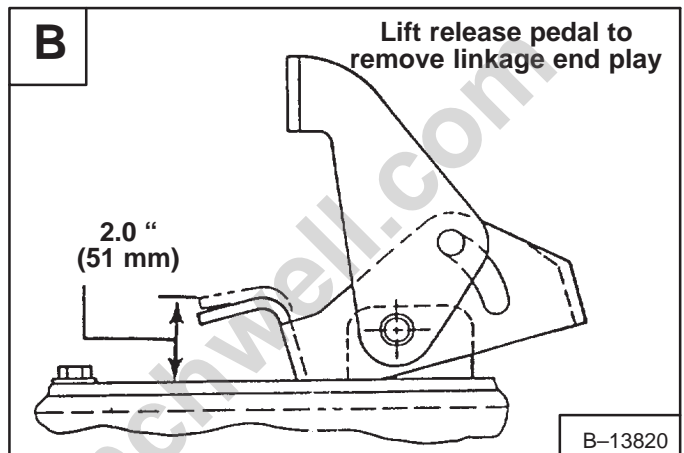
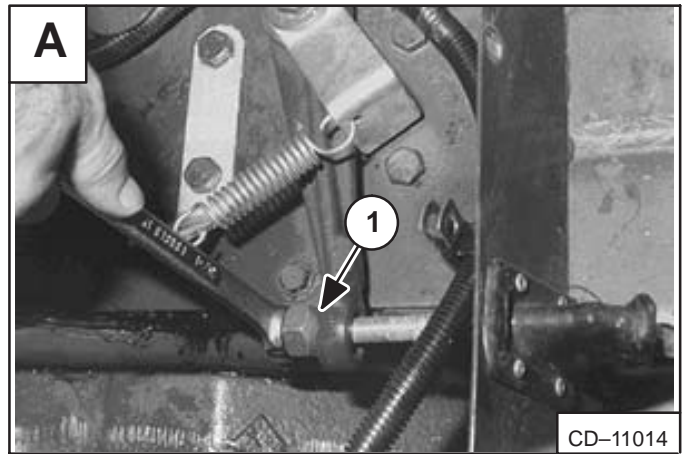

PARKING BRAKE**Removal And Installation**

WARNING

Never work on a machine with the lift arms up unless the lift arms are secured by an approved lift arm support device. Failure to use an approved lift arm support device can allow the lift arms or attachment to fall and cause injury or death.

W-2059-0598

Raise the operator cab. (See Page 1-1.)

Remove the bolt and nut from the lift pedal linkage [A].

Disconnect the lift linkage from the control valve spool [B].

Remove the pivot bolt from the lift linkage cross-member and remove the cross-member linkage (Item 1) [C].

Remove the nylon washer (Item 1) [D].

Installation: Check the nylon washer and bushing (Item 2) [D] for wear and replace as needed.

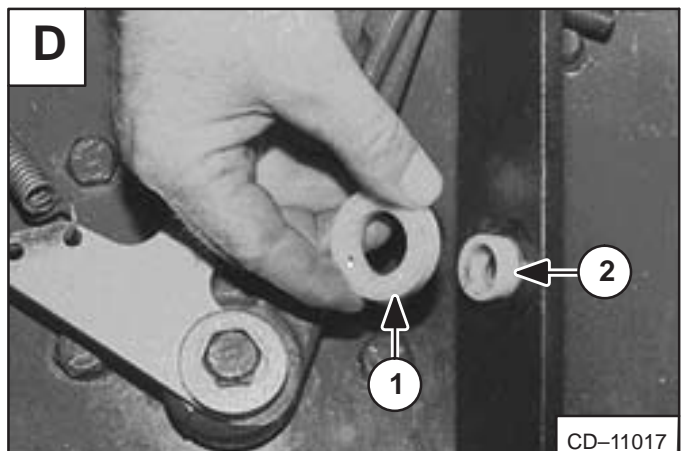
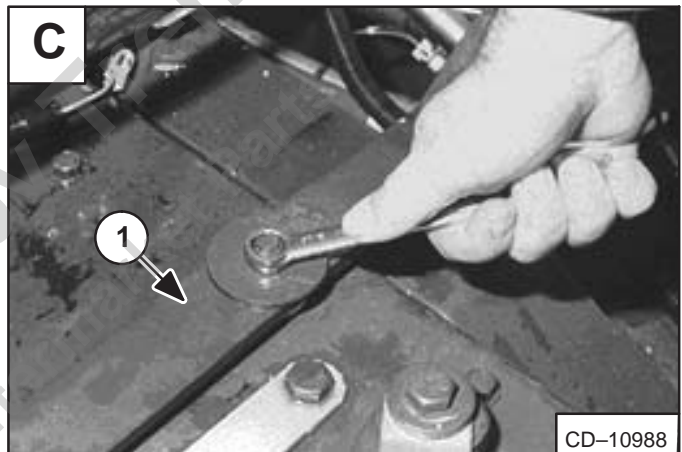
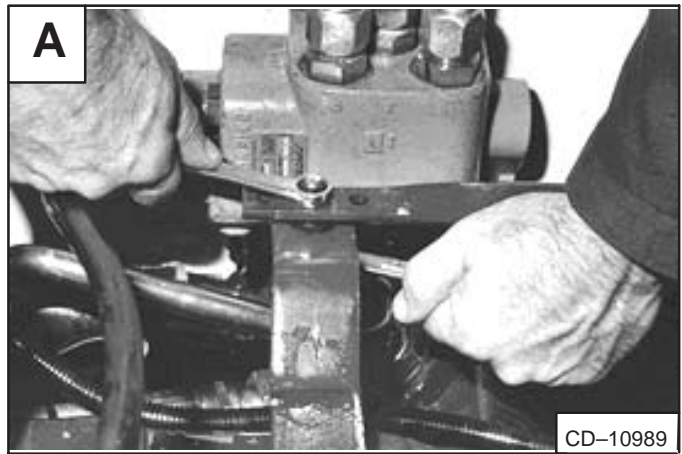

PARKING BRAKE (Cont'd)

Removal And Installation (Cont'd)

Remove the nuts from the brake linkage rod [A].

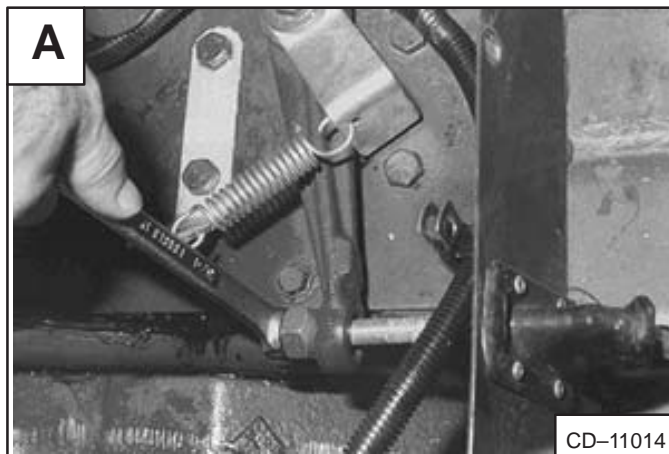

Disconnect the brake lever spring and remove the spring (Item 1) [B], retainer plate (Item 2) [B] and bolt (Item 3) [B].

Installation: Tighten the brake lever bolt to 65–70 ft.-lbs. (88–95 Nm) torque.

Remove the cover bolts [B].

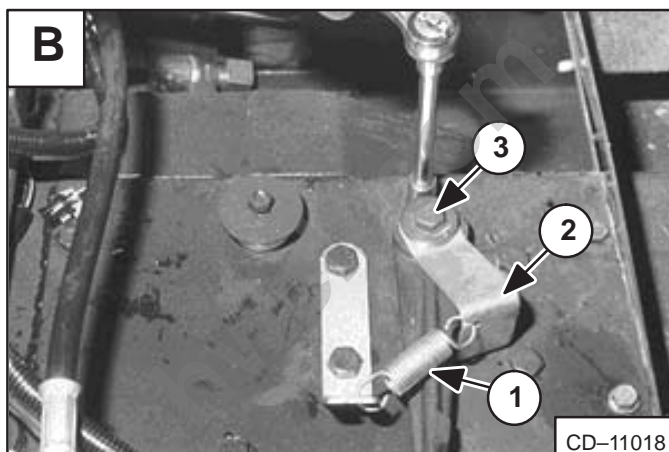

Remove the cover/brake block assembly [C].

Installation: Clean and dry the cover. Clean the surface on the chaincase where the cover sets.

Install a new gasket on the cover/brake block assembly.

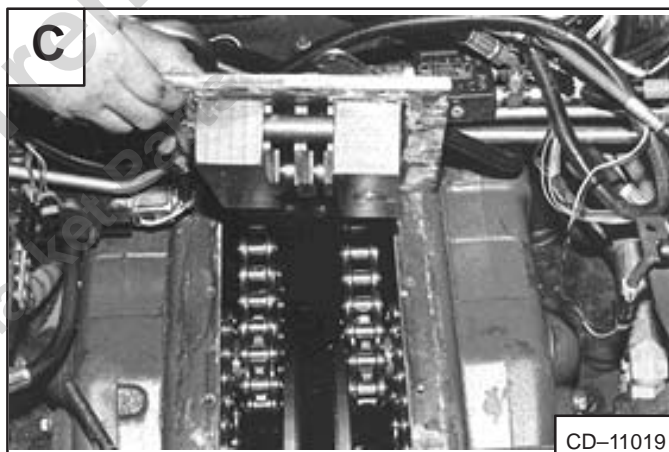

PARKING BRAKE (Cont'd)

Brake Block And Pads

Remove the brake lever [A].

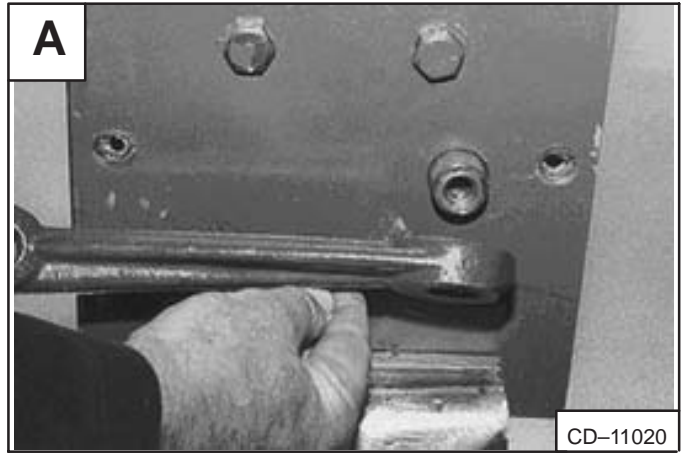

Loosen the brake pad bolts and remove the bolts [B].

Installation: Tighten the bolts to 65–70 ft.-lbs. (88–95 Nm) torque.

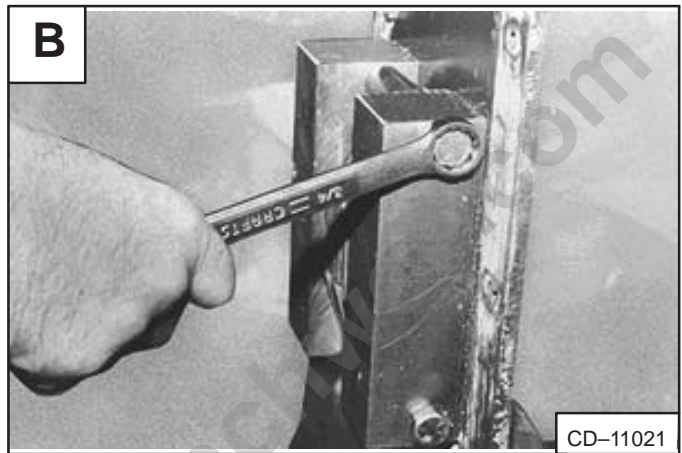

Remove the guide and pads [C].

Check the pads for wear and replace them as needed.

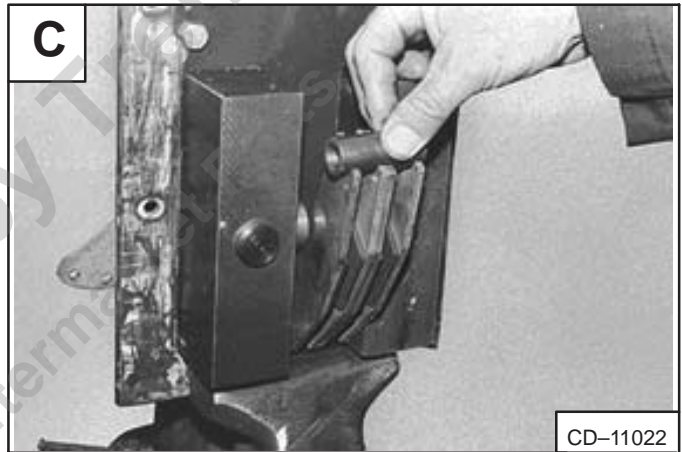

Remove the bolts which fasten the brake block to the cover [D].

Installation: Tighten the bolts to 65–70 ft.-lbs. (88–95 Nm) torque.

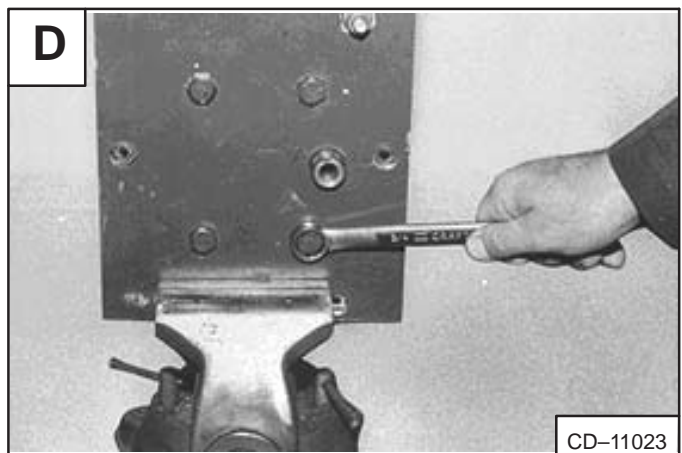

PARKING BRAKE (Cont'd)**Brake Block And Pads (Cont'd)**

Remove the brake block [A].

Installation: Clean and dry the brake block. Put a bead of R.T.V. sealant on the brake block.

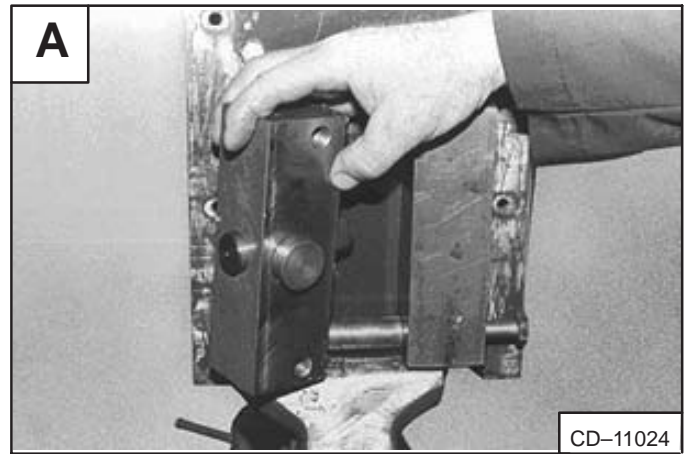

Remove the shaft from the brake block [B].

Installation: Always install a new O-ring (Item 1) [B] when the shaft is installed. Make sure the shaft rotates in the cover.

Check the parts for wear or damage and replace as needed.

Brake Discs

To remove the parking brake discs [C], use the following procedure:

MEL1242 – Port-a-Power tool is needed for the removal procedure.

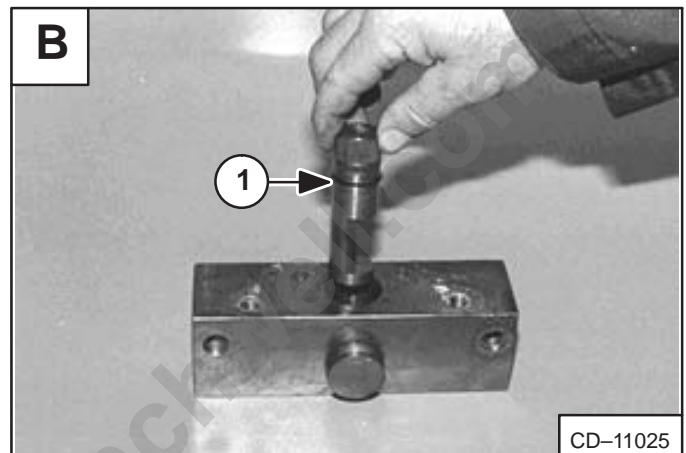

! WARNING

Never work on a machine with the lift arms up unless the lift arms are secured by an approved lift arm support device. Failure to use an approved lift arm support device can allow the lift arms or attachment to fall and cause injury or death.

W-2059-0598

Lift and block the loader. (See Page 1-1.)

Raise the operator cab. (See Page 1-1.)

Remove the front panel/steering levers assembly. (See Page 3-1.)

Remove the parking brake/cover assembly. (See Page 4-4.)

Remove the front and rear covers. (See Page 4-8.)

Remove the fluid from the chaincase. (See page 4-27.)

Remove the hydrostatic motor. (See Page 3-1.)

Remove the rear and front axles. (See Page 4-11.)

Disconnect the rear and front drive chains.

Move the gearcase away from the chaincase to slide the brake discs off.

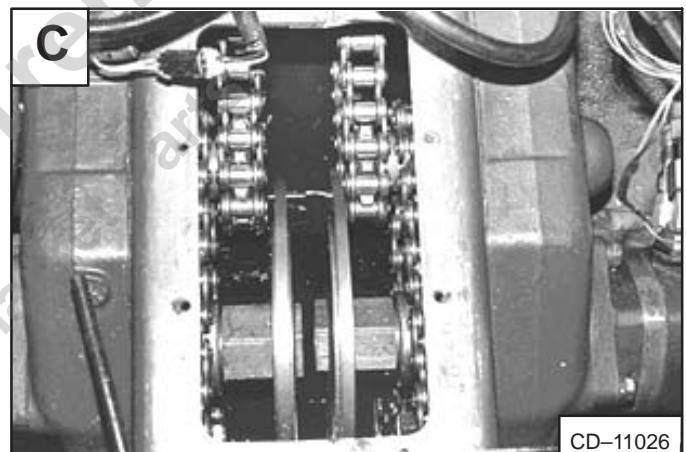

FRONT CHAINCASE COVER

Removal And Installation

Disconnect the brake pedal/linkage rod assembly [A].

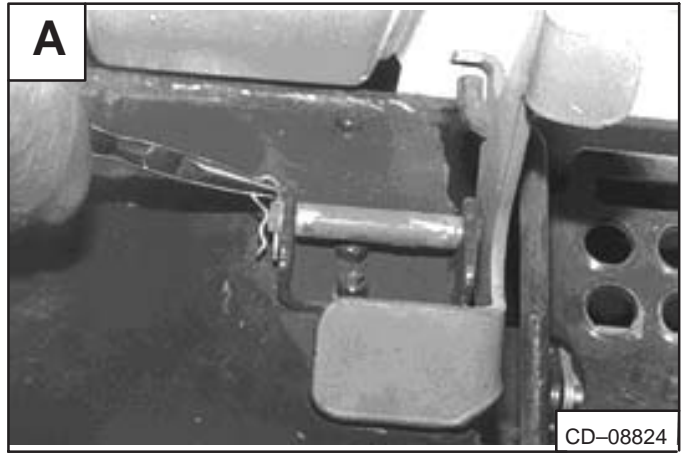

Remove the front cover mounting bolts [B].

Remove the front cover plate from the chaincase.

Installation: Clean and dry the cover. Clean the surface on the chaincase. Install a new gasket on the front cover.

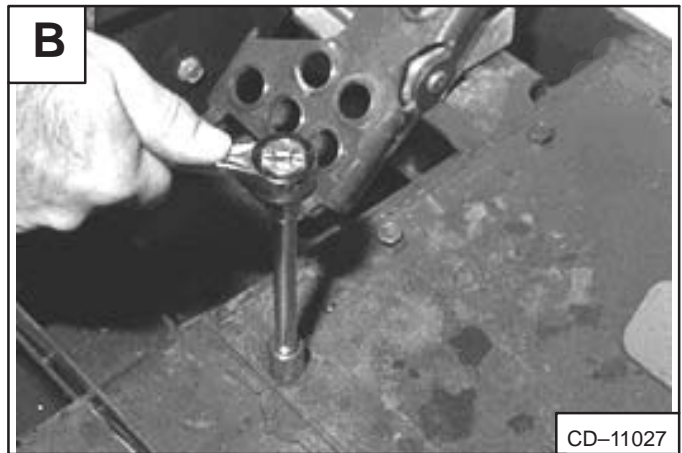

REAR CHAINCASE COVER

Removal And Installation

Remove the rear cover mounting bolts and remove the rear cover plate from the chaincase [C].

Installation: Clean and dry the cover. Clean the surface on the chaincase. Install a new gasket on the rear cover.

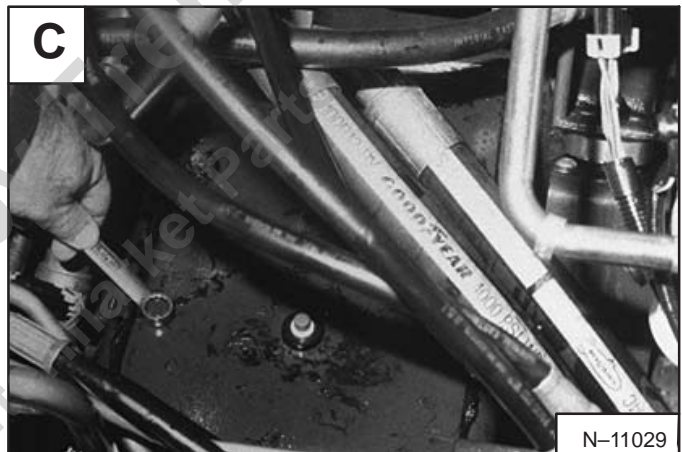

AXLE SEAL**Removal And Installation**

Lift and block the loader. (See Page 1–1.)

Remove the tire/wheel assembly.

Installation: Tighten the wheel nuts to 105–115 ft.-lbs. (142–155 Nm) torque.

Remove the bolts (Item 1) [A] and plate.

Installation: Tighten the bolts to 175–190 ft.-lbs. (240–260 Nm) torque.

Remove the two wheel studs (Item 2) [A] across from each other.

Install puller (Item 1) [B] on the wheel hub.

**WARNING**

NEVER STAND IN-LINE OF THE HUB WHEN REMOVING A HUB FROM AN AXLE. The hub has a tapered fit on the axle end and can come off the axle with great force and cause serious injury.

W-2186-0395

Remove the hub from the axle.

Remove the key (Item 1) [C] from the axle.

Drill a hole into the axle seal [D].

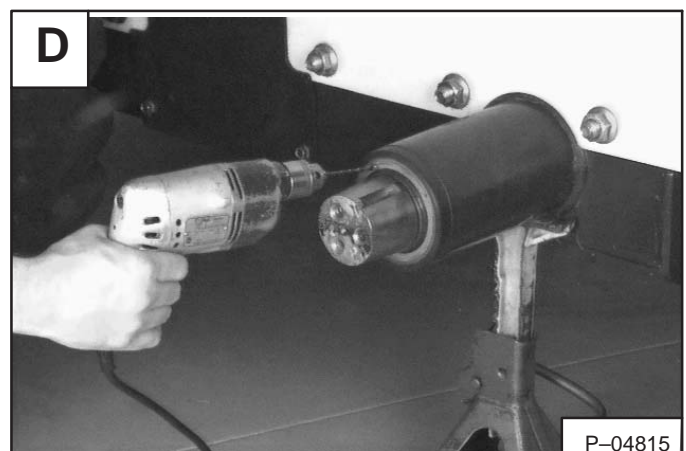
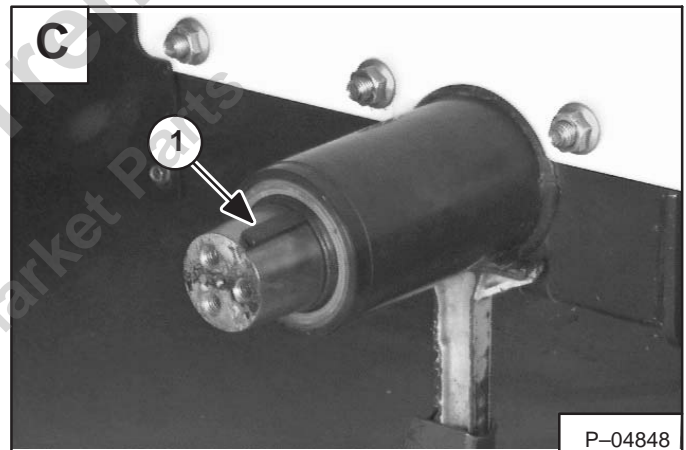
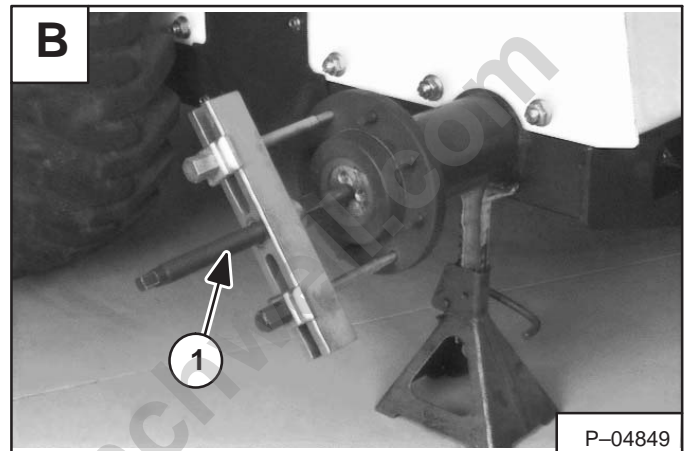
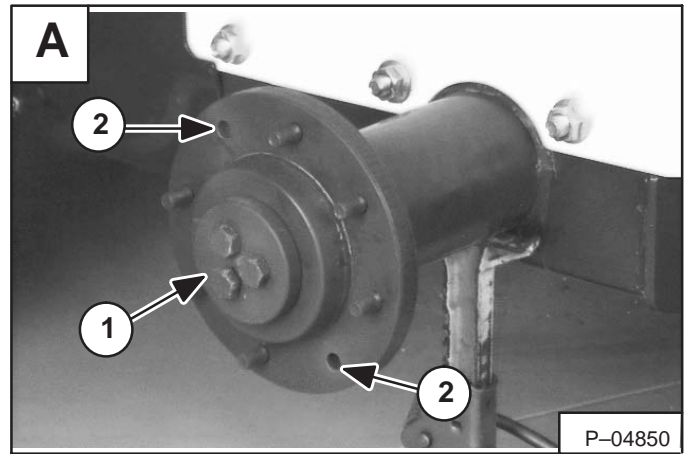

AXLE SEAL (Cont'd)**Removal And Installation (Cont'd)**

Install a slide hammer (Item 1) [A] with a screw tip end into the axle seal.

Remove the axle seal.

The tool listed will be needed to do the following procedure:

MEL1407 – Seal Installation Tool

If the axle is damaged or worn, an axle repair sleeve kit is available from Melroe Parts Sales in Chicago.

NOTE: If a new wear ring is being installed with new seal, put LOCTITE sealant on the inside diameter of the wear ring.

Place the taper on the wear ring so it faces the outside [B].

Place the seal with the lip facing in [B].

Use a hammer, install the new axle seal until the tool is flush with the edge of the axle tube [C].

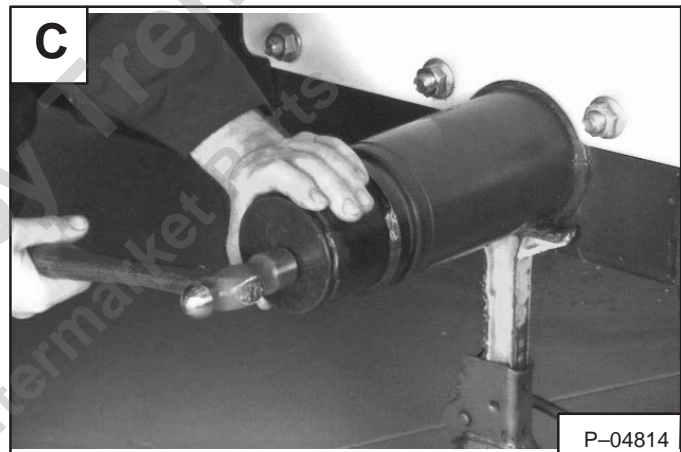
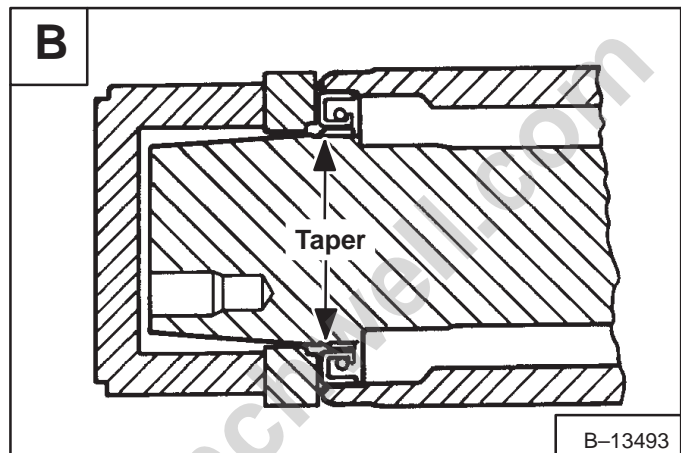
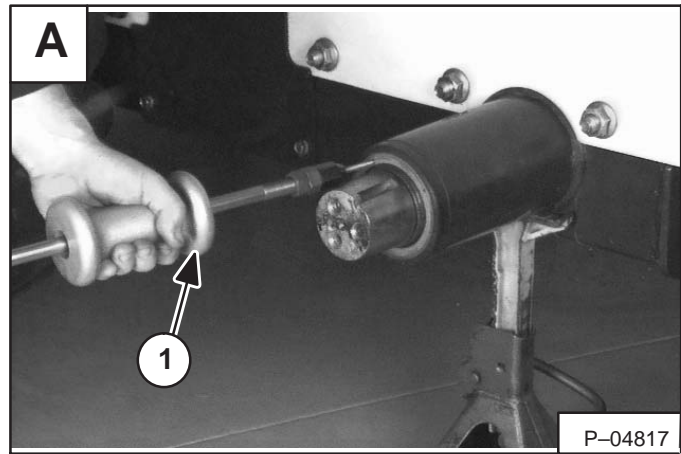

AXLE, SPROCKET AND BEARINGS

Removal And Installation

The tools listed will be needed to do the following procedure:

MEL1242 – Port-a-Power

MEL1202B – Axle Bearing Service Set

NOTE: The procedure shown for removal and installation of the axle, sprocket and bearings is for a front axle. This procedure will be the same for the rear axle also (See Page 4–8 for rear chaincase cover removal).

WARNING

Never work on a machine with the lift arms up unless the lift arms are secured by an approved lift arm support device. Failure to use an approved lift arm support device can allow the lift arms or attachment to fall and cause injury or death.

W-2059-0598

Lift and block the loader. (See Page 1–1)

Remove the front panel/steering lever assembly. (See Page 3–1.)

Remove the front cover. (See Page 4–8.)

Remove the fluid from the chaincase. (See Page 4–27.)

Loosen the axle sprocket bolt (Item 1) [A].

Installation: Tighten the axle sprocket bolt to 475–525 ft.-lbs. (644–710 Nm) torque.

Remove the bolts (Item 1) [B] and plate.

Installation: Tighten the bolts to 175–190 ft.-lbs. (240–260 Nm) torque.

Remove the two wheel studs (Item 2) [B] across from each other.

Install a puller (Item 1) [C] on the wheel hub.

WARNING

NEVER STAND IN-LINE OF THE HUB WHEN REMOVING A HUB FROM AN AXLE. The hub has a tapered fit on the axle end and can come off the axle with great force and cause serious injury.

W-2186-0395

Remove the hub from the axle.

Install a Port-a-Power ram between the two sprockets [D].

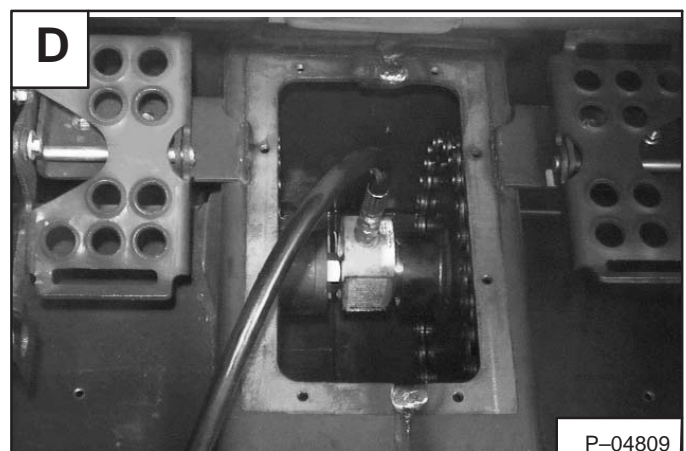
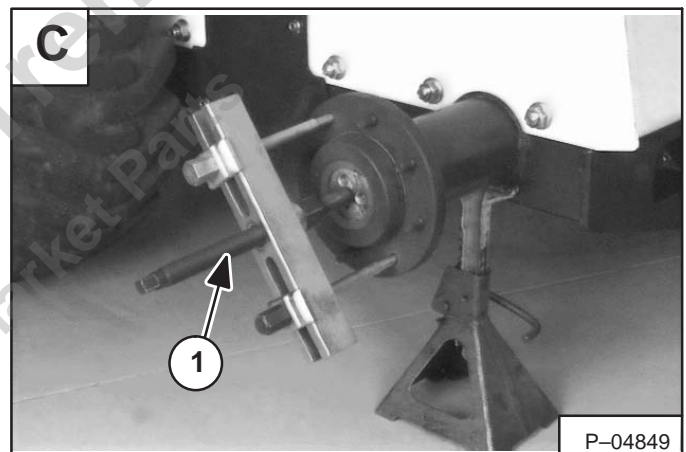
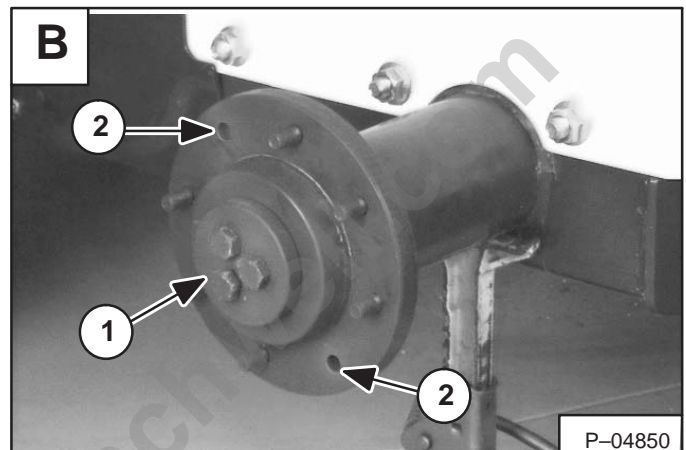
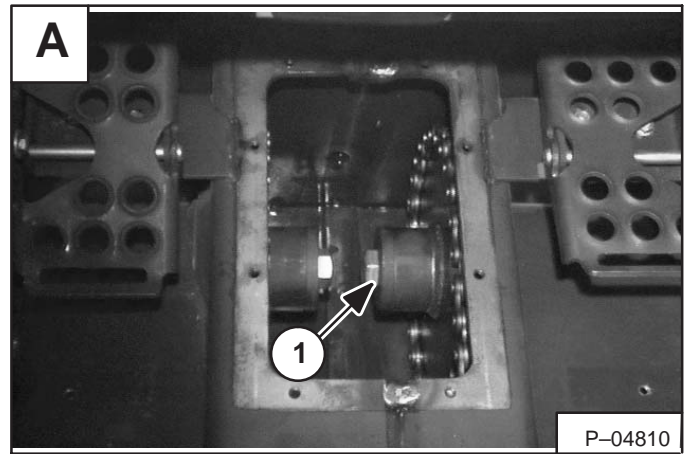

AXLE, BEARINGS AND SPROCKET (Cont'd)**Removal And Installation (Cont'd)**

Push the axle out until the ram is at the end of the stroke. Add a spacer and push the axle out again. Repeat this procedure until the axle is out of the sprocket.

Remove the drive chain from the sprocket.

Remove the sprocket (Item 1) [A] and inner bearing (Item 2) [A].

Installation: Pack the inner and outer bearing with grease before installing them.

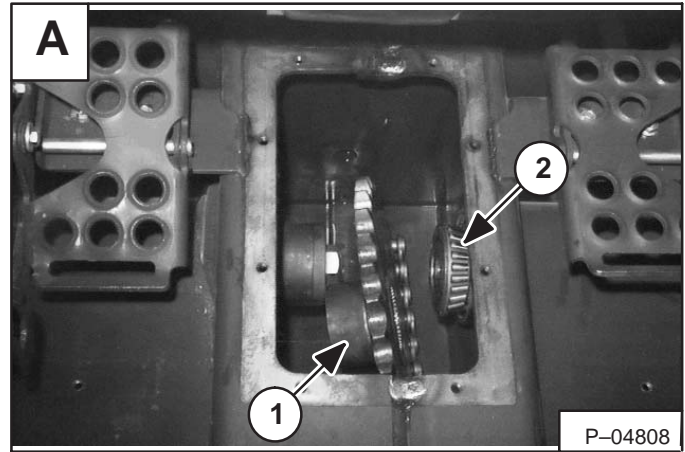

A bearing puller (Item 1) [B] is needed to do the following procedure:

Be sure the bearing puller makes good contact with the inner race and press the bearing off the mounting surface of the axle [B].

NOTE: Hold onto the axle during removal as it will slide freely after the bearing is removed from the mounting surface.

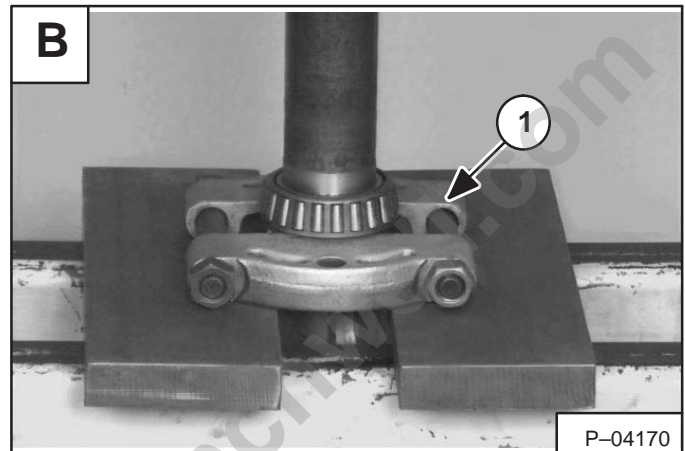

Press the splined end of the axle free from the bearing [C].



Installation: Put the spline end of the axle shaft into the bearing and press the bearing onto the axle.

NOTE: Hold onto the axle during installation as it will slide freely after the bearing is pressed over the splined end of the shaft.

Put a piece of tubing (Item 1) [D] that contacts inner race of the bearing only.

Press the bearing onto the mounting surface until the bearing is fully seated [D].

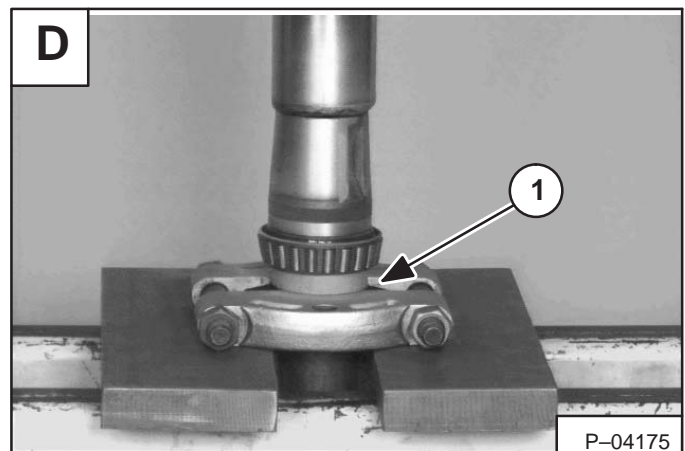

AXLE, BEARINGS AND SPROCKET (Cont'd)

Removal And Installation (Cont'd)

Use the tools provided in the (MEL1202B) Axle Bearing Service Set for bearing cup removal and installation. A slide hammer is also needed.

Use the long rod and bearing cup tool to remove the inner bearing cup [A].

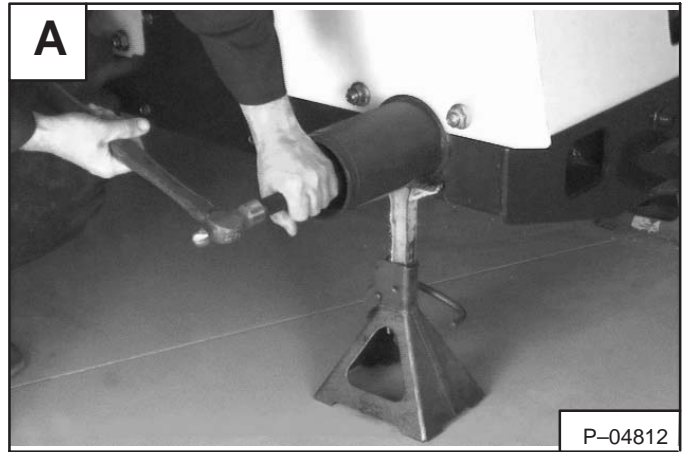

To remove the outer bearing cup, install a bearing cup tool on the slide hammer.

Leave the bearing cup tool loose until the tool is installed inside the tube [B].

Pull the tool against the bearing cup and tighten the nut.



Use the slide hammer and remove the bearing cup from the axle tube [C].

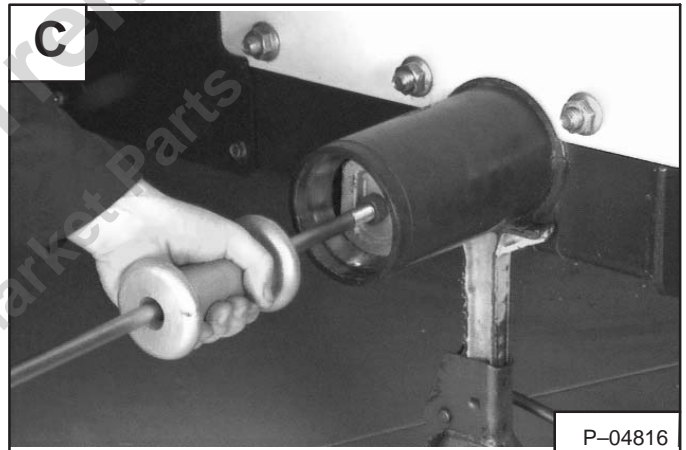

Provided for Free by Trenchless.com
Shop Aftermarket Parts

AXLE, BEARING AND SPROCKET (Cont'd)**Removal And Installation (Cont'd)**

Use the bearing cup installation tools (Item 1) **[A]** & (Item 1) **[B]**.

Put the inner cup (Item 2) **[A]** in the axle tube.

Install the long threaded rod (Item 2) **[B]** into the axle tube and through the installation tool (Item 1) **[A]**.

Install the nut (Item 3) **[A]**.

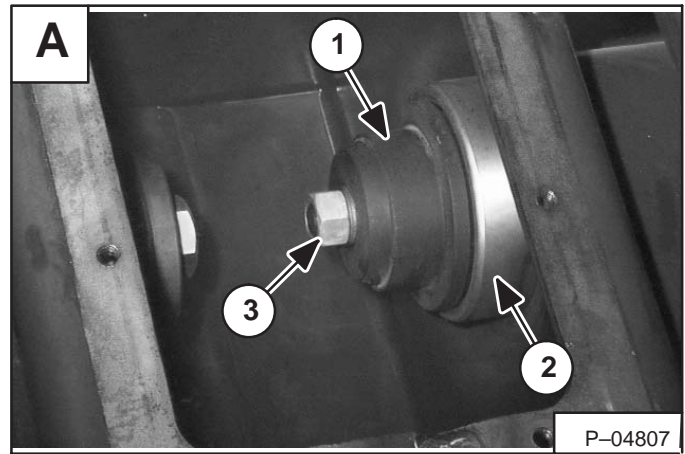

Install the installation tool (Item 1) **[B]** on the threaded rod. Install the nut.

Hold the inside nut (Item 3) **[A]** with a wrench and tighten the outside nut **[B]**.

Tighten the nut until the bearing cup is installed inside the axle tube.

Remove the installation tools and threaded rod.

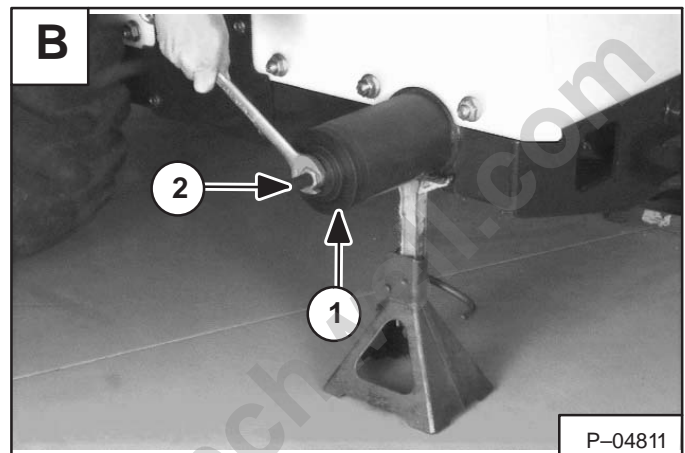

To install the outer bearing cup, install the bearing cup tool on the driver handle.

Install the bearing cup into the axle tube, and put the tool into the bearing cup.

Hit the driver handle with a hammer until the bearing cup is installed inside the axle tube **[C]**.

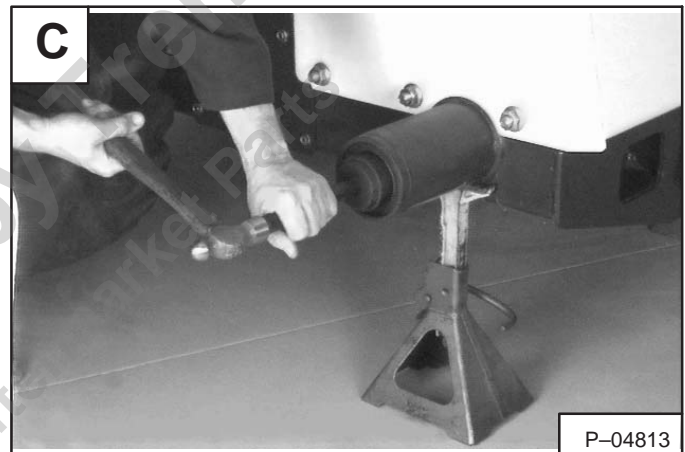

REDUCTION GEARCASE

Reduction Gearcase Seal

The tool listed will be needed to do the following procedure:

MEL1047 – Seal Installation Tool

Lift and block the loader. (See Page 1–1.)

Remove the hydrostatic motor. (See Page 3–1.)

Drill a hole into the reduction gearcase seal **[A]**.

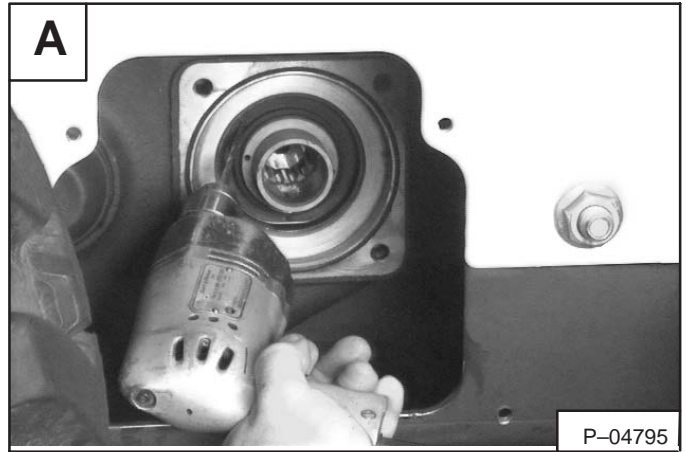

Install a slide hammer with a screw tip end into the seal **[B]**.

Remove the reduction gearcase seal.



Install the new quad ring on the installation tool.

Install the backup washer.

Use a hammer, hit the installation tool until the quad ring is fully seated **[C]**.



REDUCTION GEARCASE (Cont'd)

Removal And Installation

**WARNING**

Never work on a machine with the lift arms up unless the lift arms are secured by an approved lift arm support device. Failure to use an approved lift arm support device can allow the lift arms or attachment to fall and cause injury or death.

W-2059-0598

Lift and block the loader. (See Page 1-1.)

Raise the operator cab. (See Page 1-1.)

Remove the front panel/steering levers assembly. (See Page 3-1.)

Remove the hydraulic control valve if the right side reduction gearcase is removed. (See Page 2-1.)

Remove the center cover. (See Page 4-4.)

Remove the front cover. (See Page 4-7.)

Remove the fluid from the chaincase. (See Page 4-27.)

Remove the hydrostatic motor. (See Page 3-1.)

Remove the front axle. (See Page 4-11.)

Remove the reduction gearcase mounting bolts (Item 1) [A].

Installation: Tighten the mounting bolts to the following torque:

3/4 inch Bolt – 220–245 ft.-lbs. (300–330 Nm)
1/2 inch Bolt – 65–70 ft.-lbs. (88–95 Nm)

Remove the front and the rear drive chains from the cluster sprocket.

Connect a chain hoist as shown in figure [B].

Remove the reduction gearcase from the chaincase [B].

Installation: Make sure the large ring (Item 1) [C] and the O-ring (Item 2) [C] are in position before tightening the bolts.

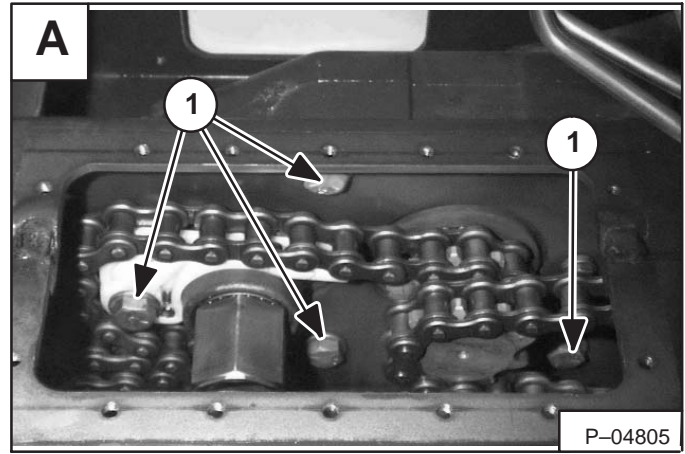

P-04805

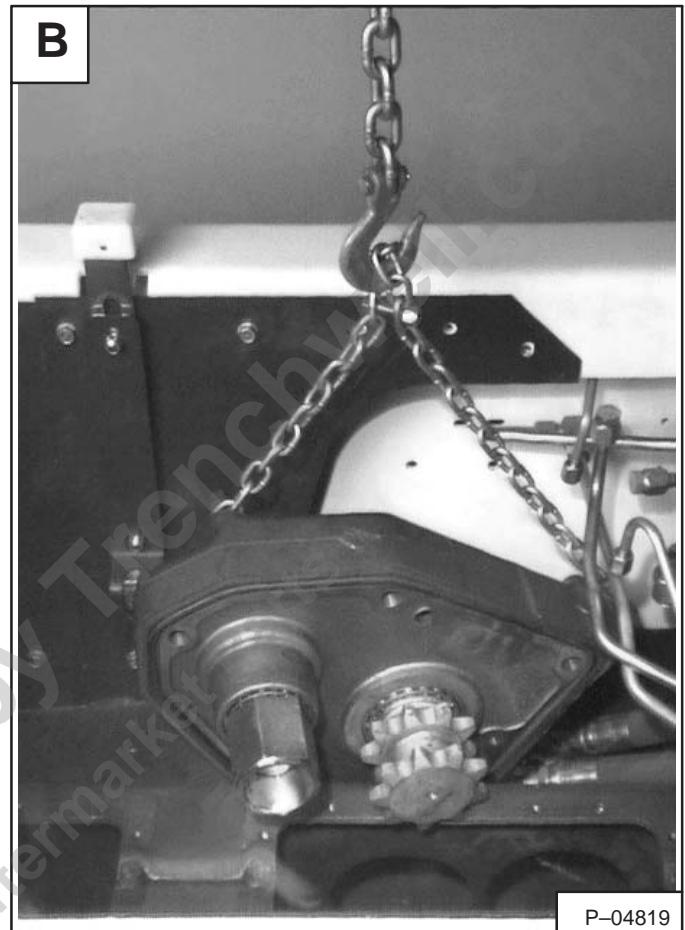

P-04819

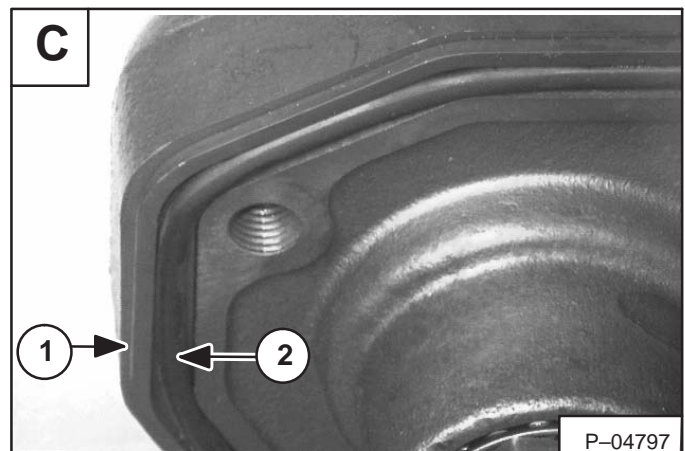

P-04797

REDUCTION GEARCASE (Cont'd)**Checking Reduction Gearcase**

Before disassembly of the gearcase do the following checks:

Install a dial indicator on the input shaft **[A]**. The end play must be between 0.00–0.010 inch (0,0254 mm.) If not, the following parts may need replacing: Bearing, bearing cups, gear or gearcase housing.

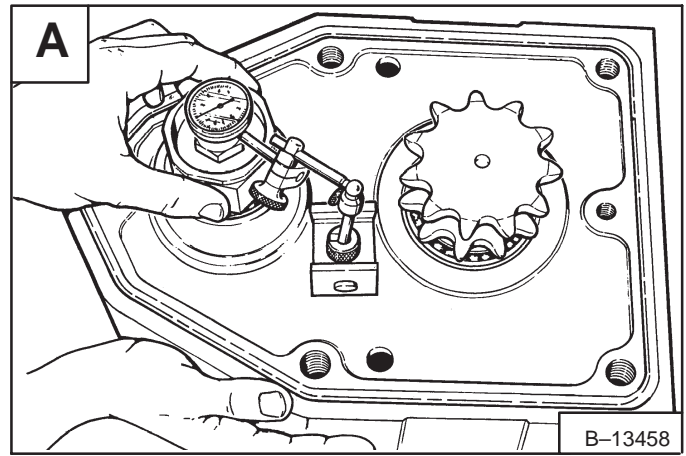

Install the dial indicator on the output shaft **[B]**. The end play must be between 0.00–0.010 inch (0,0254 mm.) If not, the following parts may need replacing: Bearing, bearing cups, gear or gearcase housing.

Remove the seal (See Page 4–15.)

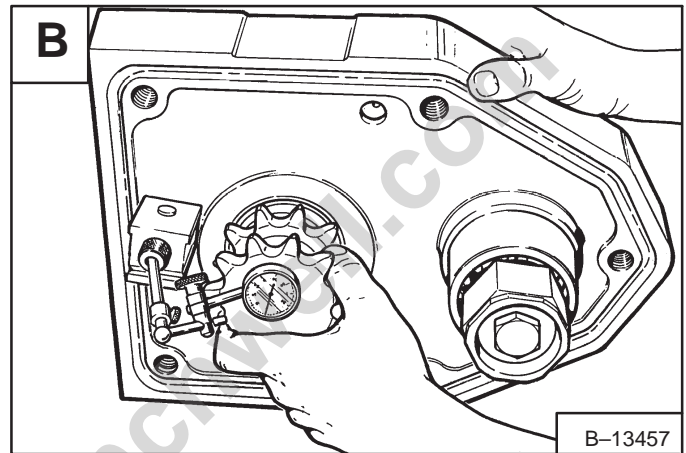

Install a feeler gauge between the teeth of the gears **[C]**.

The back lash must be between 0.003–0.009 inch (0,076–0,228 mm.) If not, the following parts may need replacing: Large gear or the shaft.

Measure the bore diameter for the seal. Correct diameter is 3.750 ± 0.001 inch ($95,25 \pm 0,025$ mm.) Install a dial indicator on the input shaft. Set the indicator so the stylus is against the pilot bore for the drive motor. Rotate the shaft 360 degrees. Maximum run-out should not exceed 0.009 inch (0,23 mm.) If either check (Bore I.D. & Run-Out) is not within these specifications, replace the gearbox.

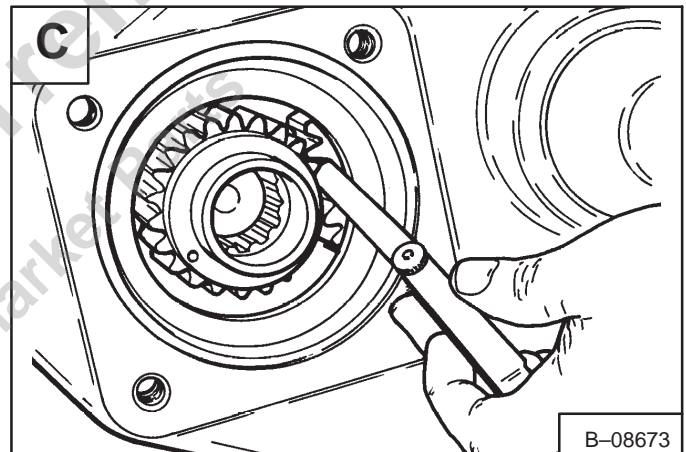
**Disassembly**

The tool listed will be needed to do the following procedure:

MEL1047 – Seal Installation Tool

Remove the bolts from the end plate **[D]**.

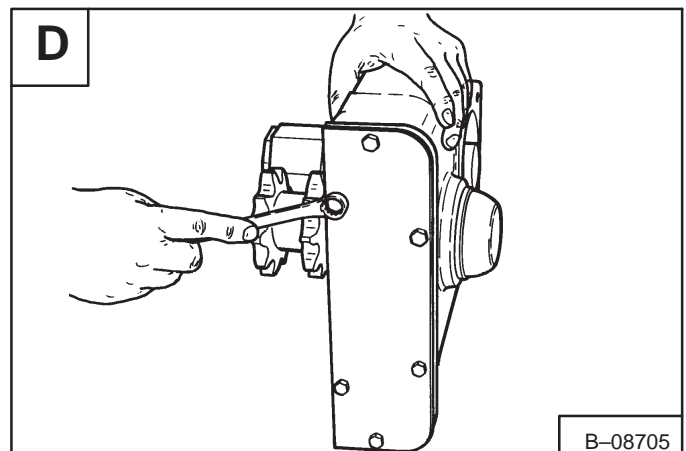

REDUCTION GEARCASE (Cont'd)

Disassembly (Cont'd)

Remove the end plate [A].

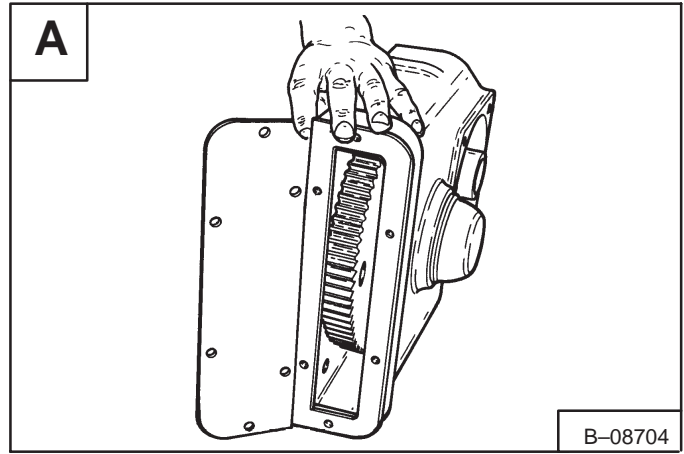

Remove the dust cap [B].

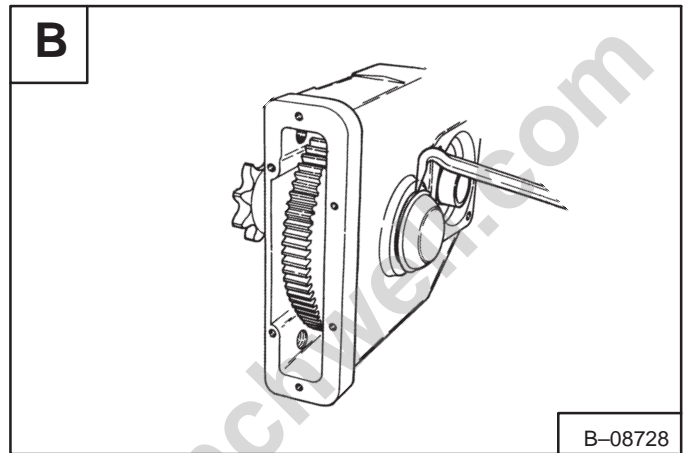

Loosen the bolt from the output shaft [C].

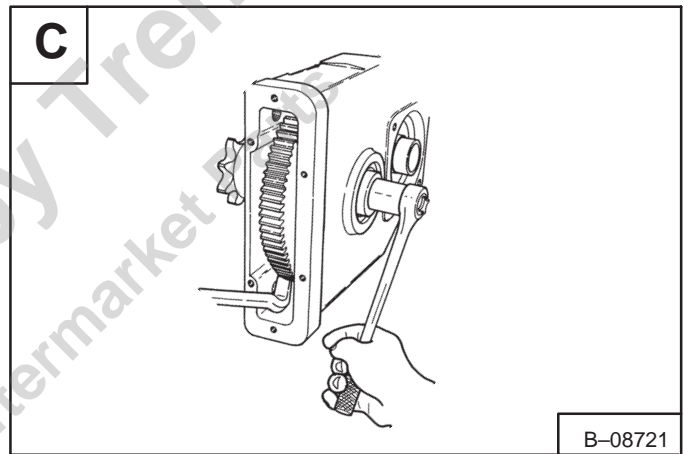

Remove the bolt and washer [D].

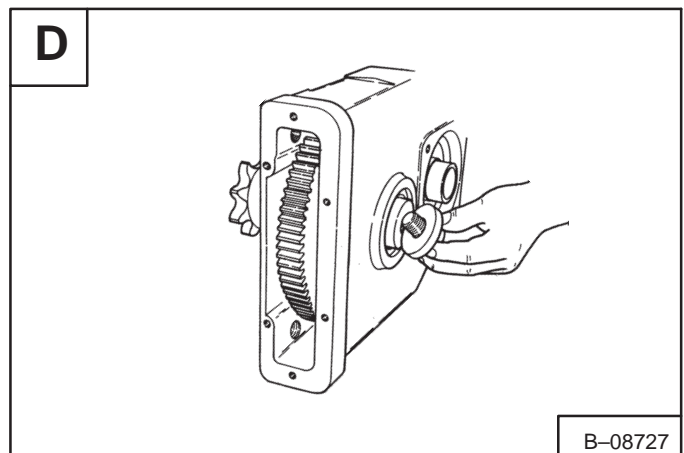

REDUCTION GEARCASE (Cont'd)

Disassembly (Cont'd)

Remove the bolt from the disc hub [A].

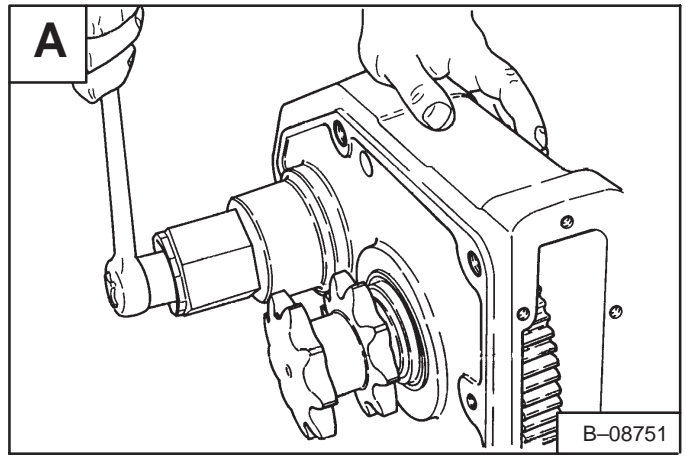

Remove the bolt and washer [B].

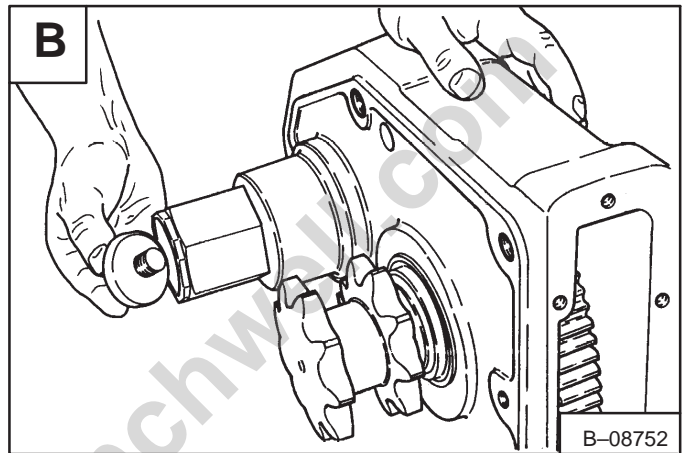

Remove the disc hub and key [C].

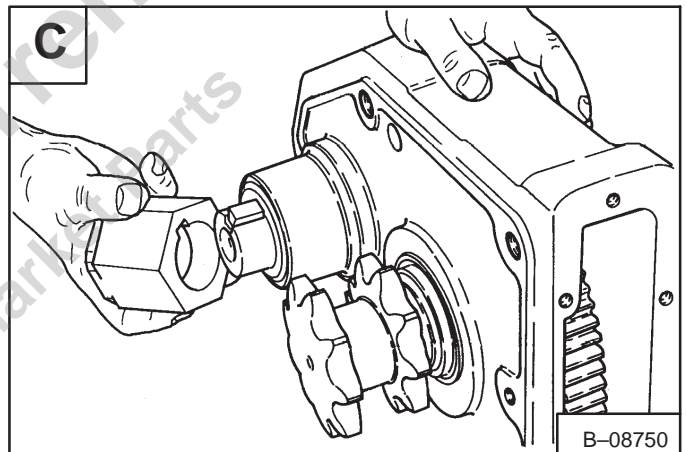

Put the gearcase housing in the press and remove the output shaft [D].

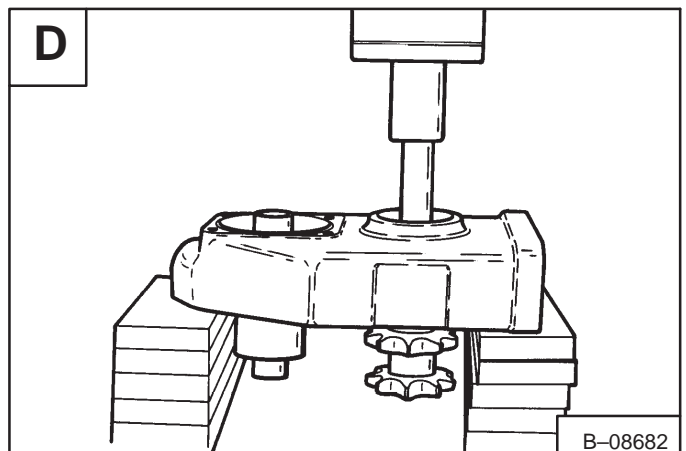

REDUCTION GEARCASE (Cont'd)

Disassembly (Cont'd)

Remove the bearing [A].

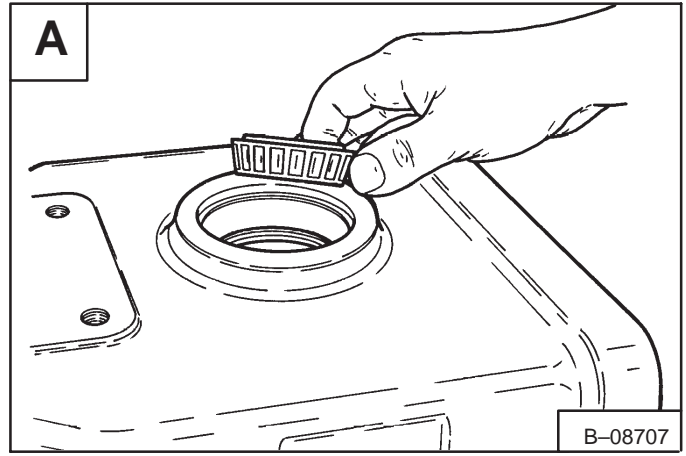

Remove the spacer [B].

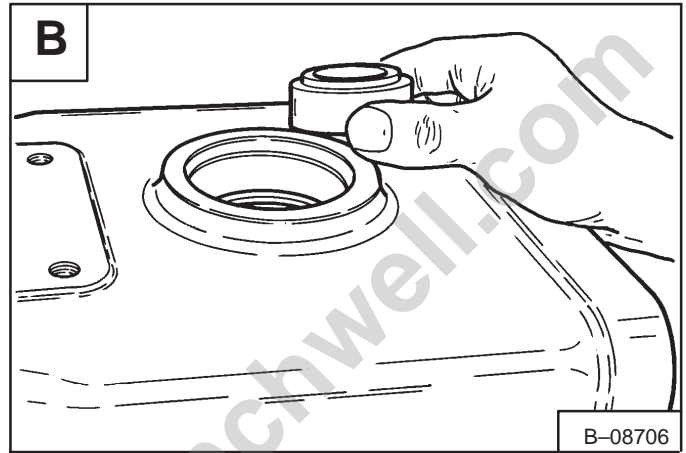

Remove the output shaft [C].

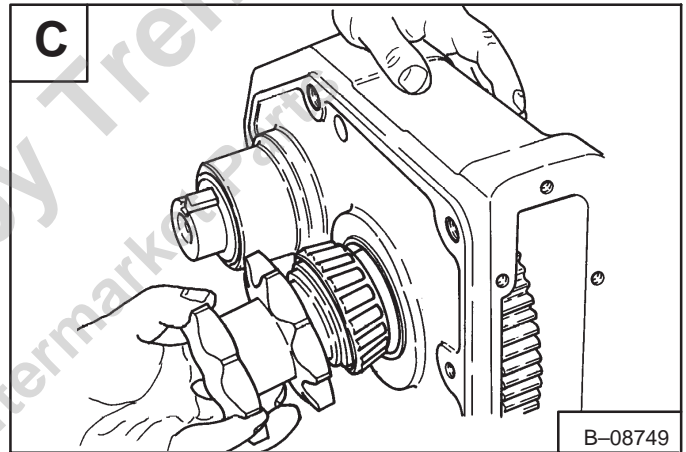

Remove the large gear [D].

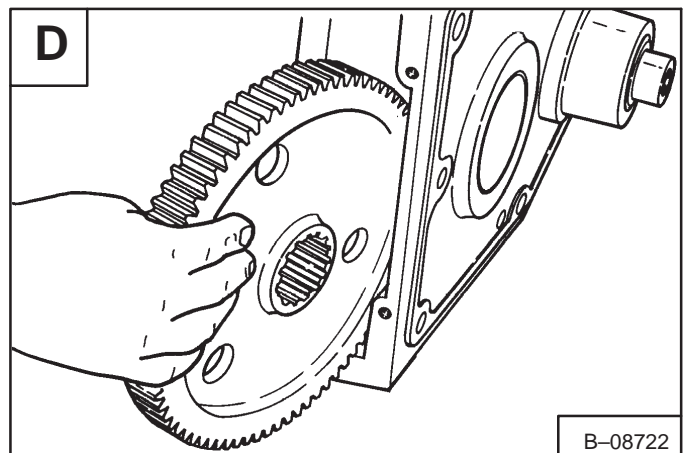

REDUCTION GEARCASE (Cont'd)

Disassembly (Cont'd)

Remove the bearing at the input shaft **[A]**.

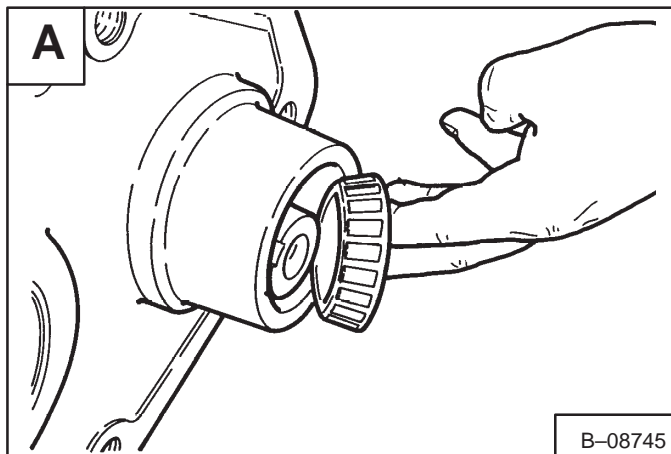

Use a press and remove the input shaft **[B]**.

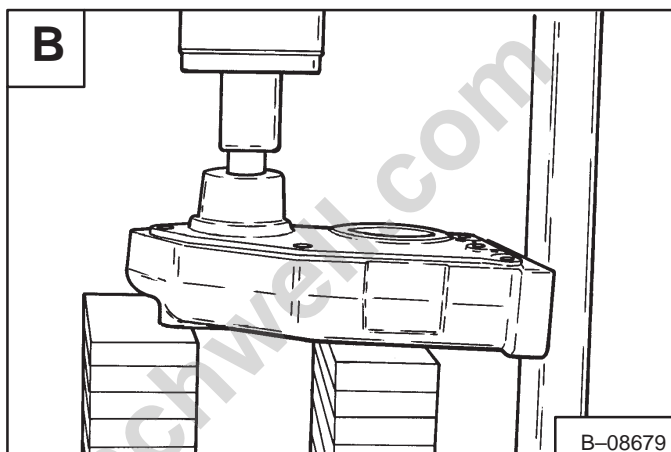

Remove the input shaft assembly from the housing **[C]**.

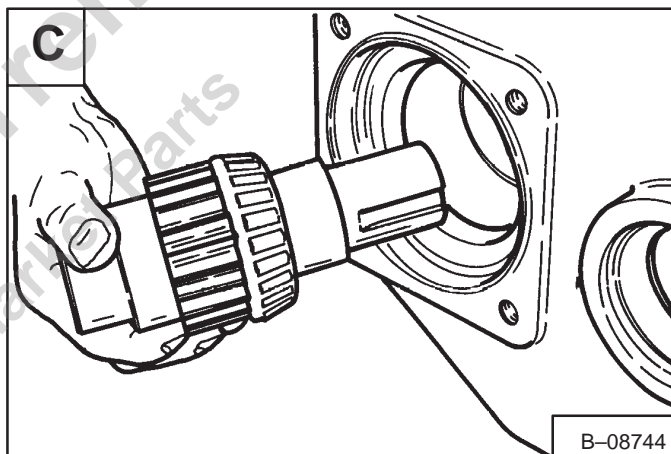

Use a punch and hammer and remove the bearing cups as needed **[D]**.

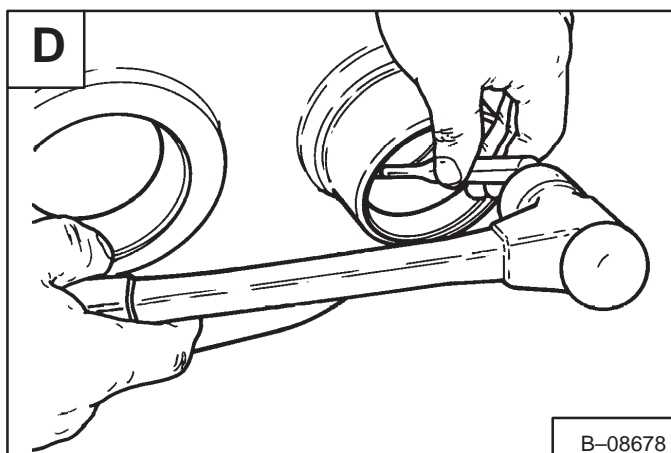

REDUCTION GEARCASE (Cont'd)

Assembly

Using a press and bearing cup tool, install the bearing cup in the housing.

Install the input shaft [A].

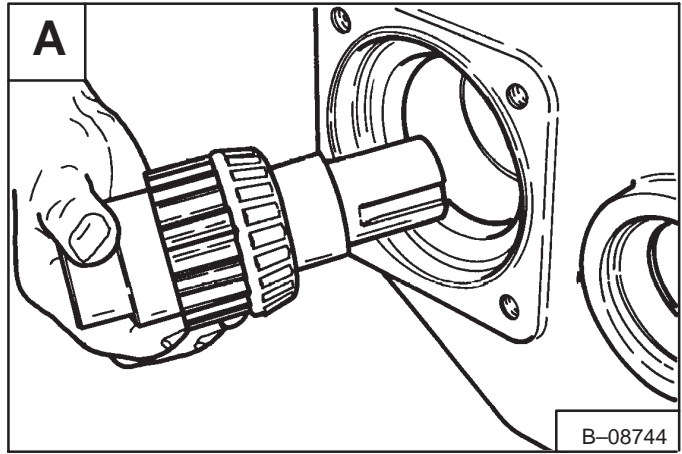

Install the bearing on the input shaft [B].

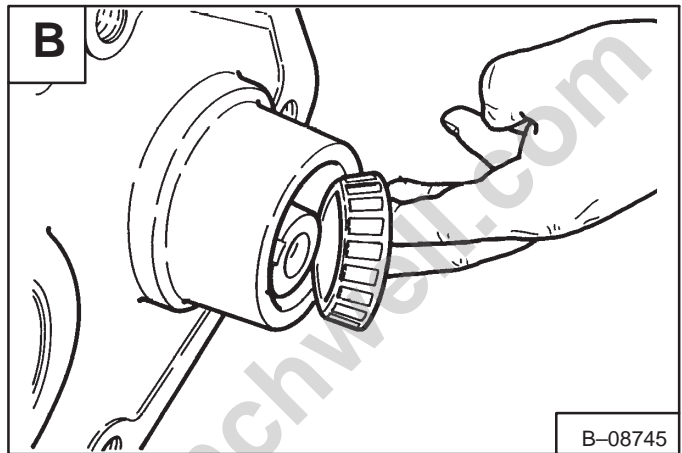

Install the large gear into the housing [C].

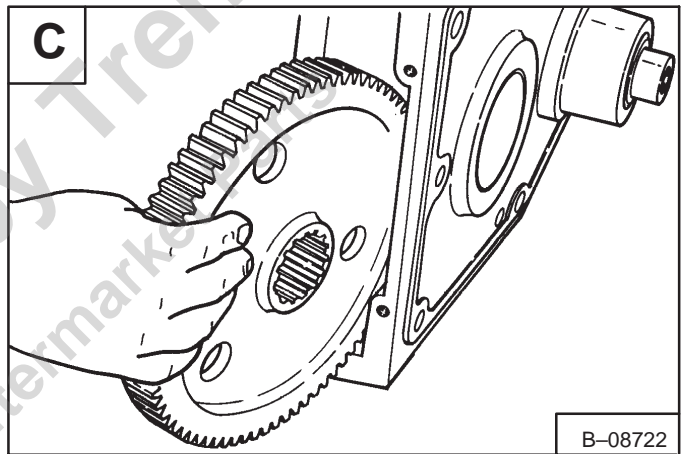

Install the output shaft into the housing and large gear [D].

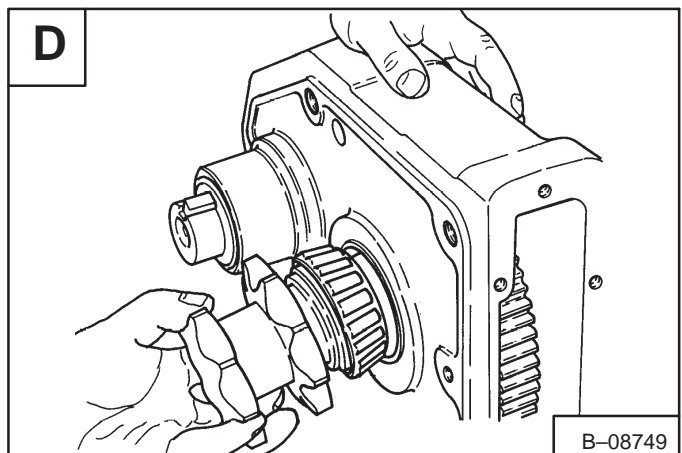

REDUCTION GEARCASE (Cont'd)**Assembly (Cont'd)**

Install the spacer **[A]**.

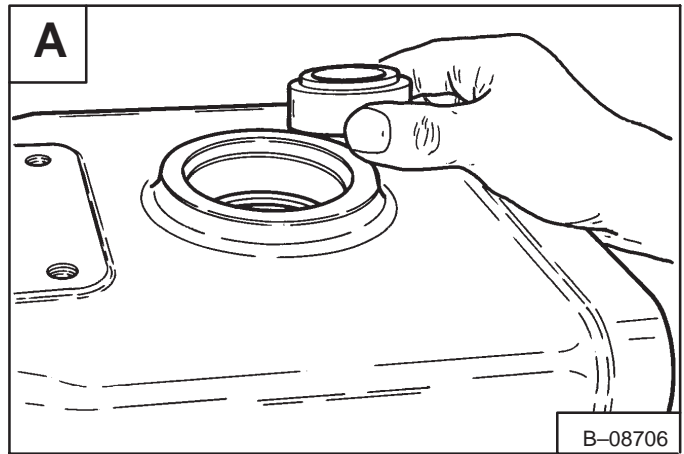

Install the bearing **[B]**.

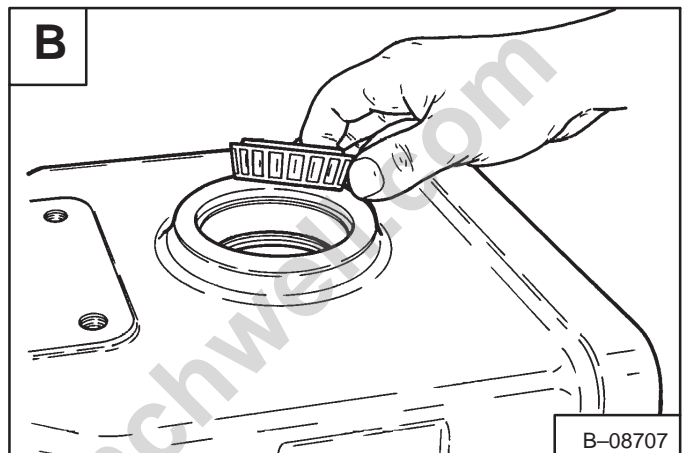

Put LOCTITE on the bolt.

Install the bolt and washer **[C]**.

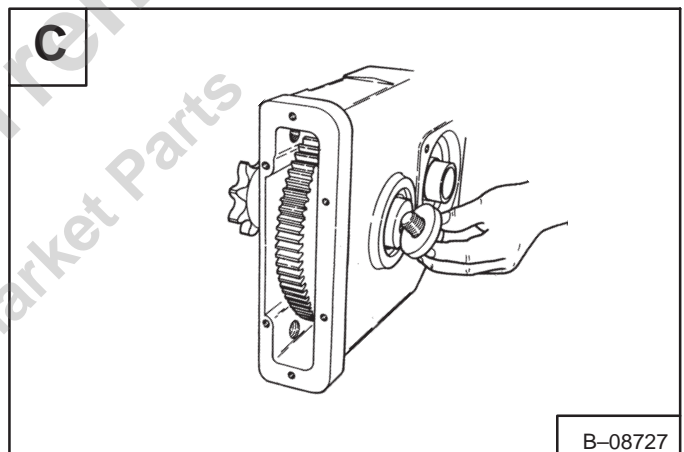

Tighten the bolt to 210–235 ft.-lbs. (285–305 Nm) torque **[D]**.

Put *Boretite* sealant on the edge of the dust cup and install the dust cup into the housing.

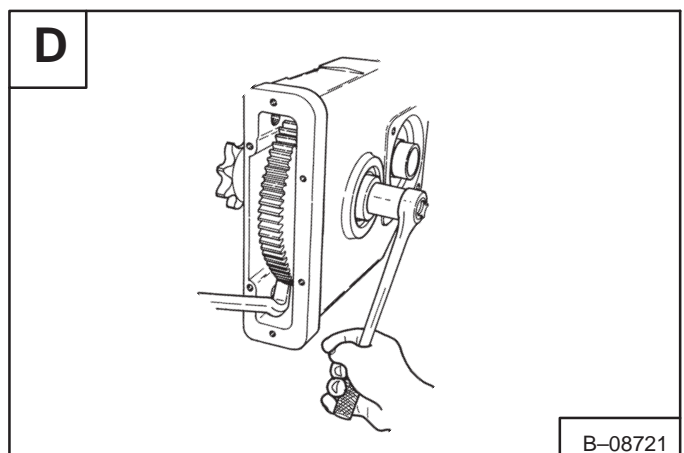

REDUCTION GEARCASE (Cont'd)

Assembly (Cont'd)

Install the key and hub on the input shaft **[A]**.

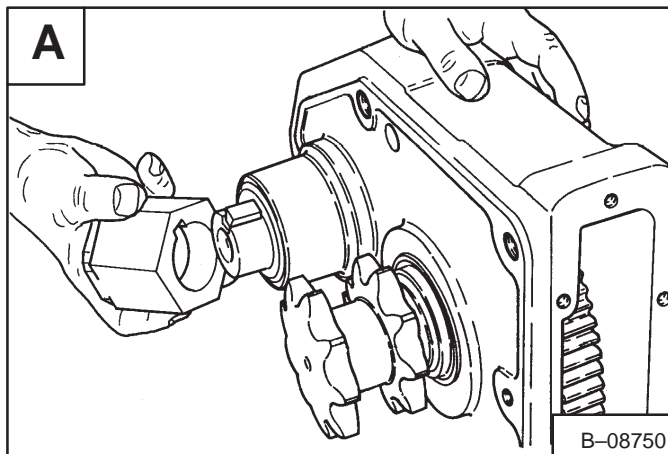

Put LOCTITE #242 adhesive on the bolt threads.

Install the bolt and washer **[B]**.

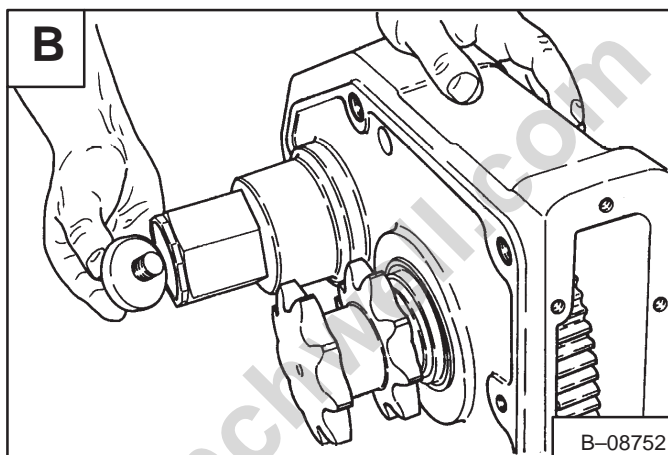

Tighten the bolt to 210–235 ft.-lbs. (285–305 Nm) torque **[C]**.

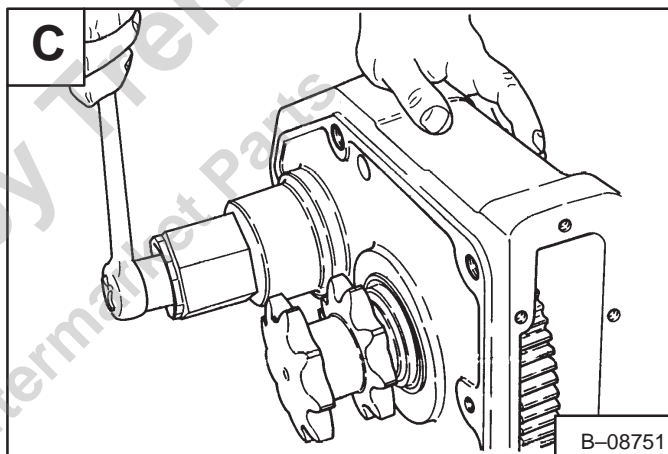

Install the end plate on the housing **[D]**.

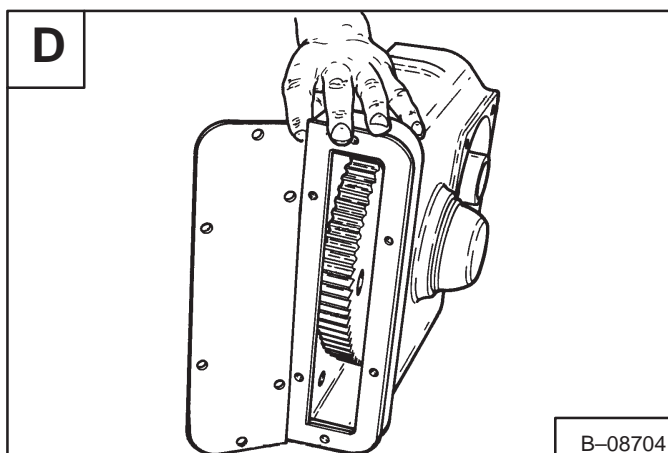

REDUCTION GEARCASE (Cont'd)

Assembly (Cont'd)

Install the end plate bolts and tighten to 13–14 ft.-lbs. (Nm) torque [A].

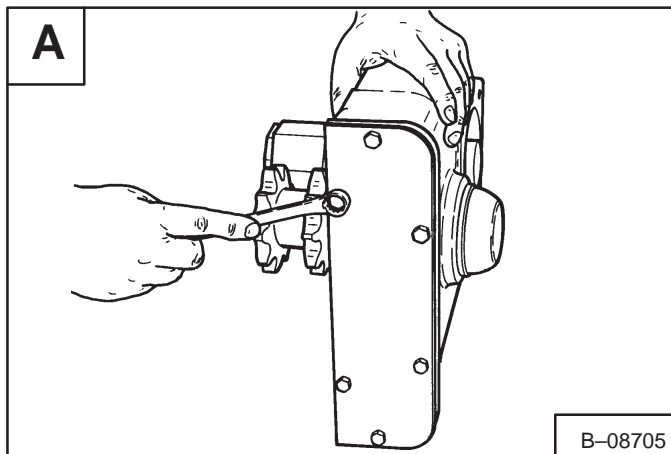

Install a new quad ring. Install the backup washer [B].

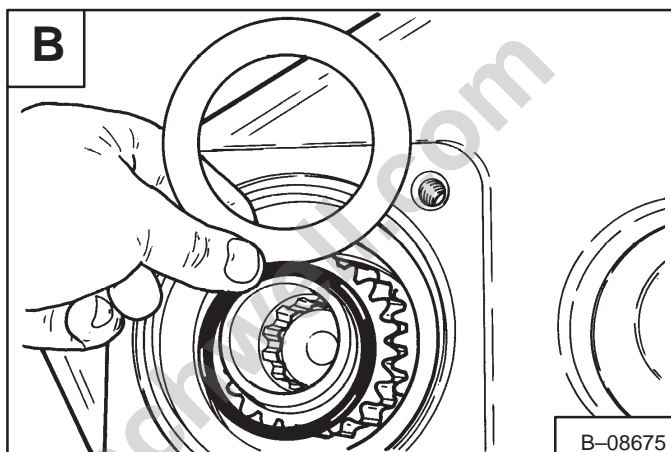

Install the new seal using the seal installation tool [C].

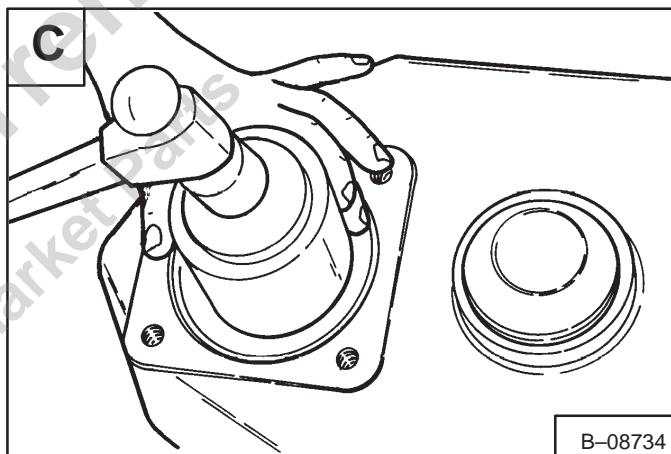

DRIVE CHAIN**Removal And Installation****WARNING**

Never work on a machine with the lift arms up unless the lift arms are secured by an approved lift arm support device. Failure to use an approved lift arm support device can allow the lift arms or attachment to fall and cause injury or death.

W-2059-0598

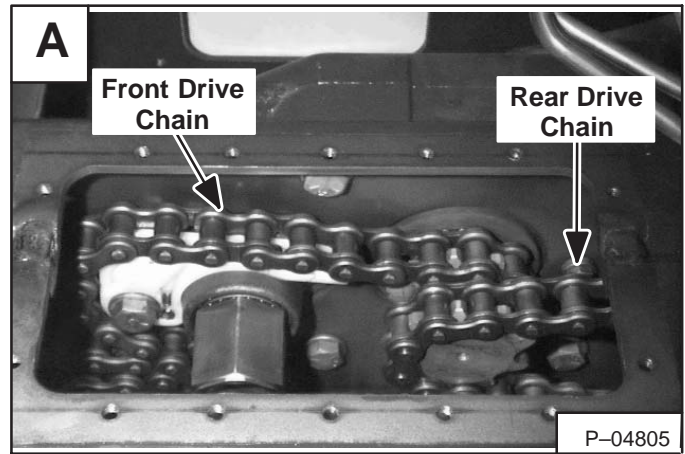

Lift and block the loader. (See Page 1-1.)

Raise the operator cab. (See Page 1-1.)

Removing the front panel/steering lever assembly. (See Page 3-1.)

Remove the center chaincase cover. (See Page 4-5.)

Remove the front and rear chaincase cover. (See Page 4-8.)

Remove the fluid from the chaincase. (See Page 4-27.)

Remove the rear axle. (See Page 4-11.)

NOTE: It is necessary to remove the rear axle and drive chain [A]. If the front chain has to be removed.

CHAINCASE FLUID

Removing The Fluid From The Chaincase

To drain the oil from the chaincase, remove the cover (Item 1) **[A]** which is installed over the drain plug at the rear of the chaincase.

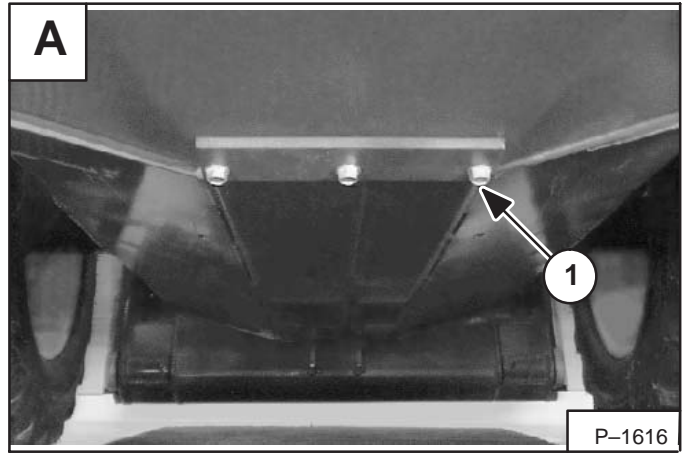

Remove the drain plug (Item 1) **[B]** and drain the oil into a container.

Check the drain plug and replace if necessary.

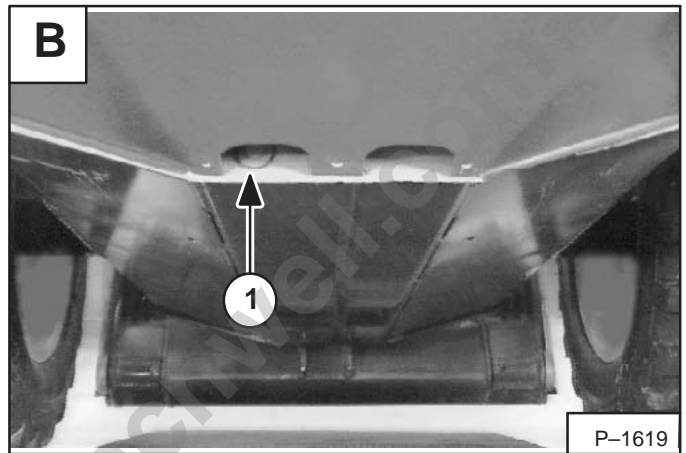

Provided for Free by Trendsetter
Shop Aftermarket Parts



Provided for Free by www.franchwell.com
Shop Aftermarket Parts

MAIN FRAME

	Page Number
BOB-TACH	
Bob-Tach Lever And Wedge	5-9
Bob-Tach Stops	5-10
Removal And Installation	5-7
FUEL TANK	
Fuel Level Sender	5-16
Inlet Screen	5-16
Removal And Installation	5-15
LIFT ARMS	
Removal And Installation	5-11
OPERATOR CAB	
Removal And Installation	5-5
OPERATOR CAB GAS CYLINDER	
Disassembly And Assembly	5-4
Removal And Installation	5-3
REAR DOOR	
Bumper Removal And Installation	5-14
Door Latch And Catch Adjustment	5-14
Door Latch Removal And Installation	5-14
Hood Removal And Installation	5-14
Removal And Installation	5-13
REAR GRILL	
Removal And Installation	5-12

**MAIN
FRAME**



bobcat®

Provided for Free by Trenchwell.com
Shop Aftermarket Parts

OPERATOR CAB GAS CYLINDER

Removal And Installation

 **WARNING**

Never work on a machine with the lift arms up unless the lift arms are secured by an approved lift arm support device. Failure to use an approved lift arm support device can allow the lift arms or attachment to fall and cause injury or death.

W-2059-0598

 **WARNING**

Cylinder contains high pressure gas. Do not open. Opening cylinder can release rod and cause injury or death.

W-2113-0288

Remove the operator cab stop (Item 1) [A] (both sides).

NOTE: Be careful not to break the rear window when the cab is raised after the cab stops are removed.

Raise the operator cab (See Page 1-1).

Remove the nuts (Item 1) [B] from the gas cylinder mounting bracket.

Move the mounting bracket to relieve any remaining tension on the gas cylinder [C].

Remove the cotter pin (Item 1) [D] from the top pivot pin.

Remove the pivot pin and bushing from the gas cylinder.

Remove the gas cylinder.

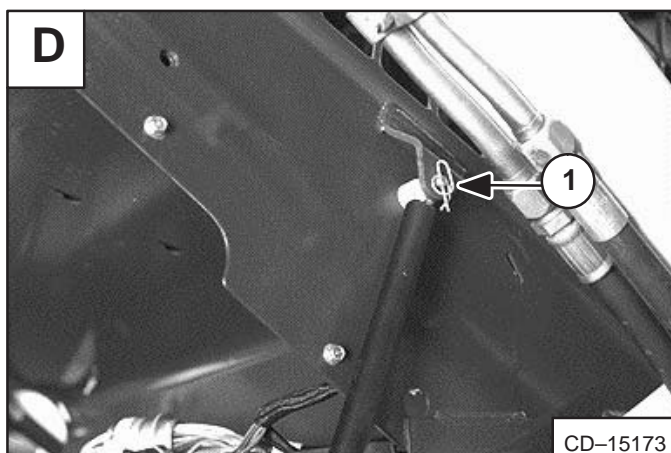
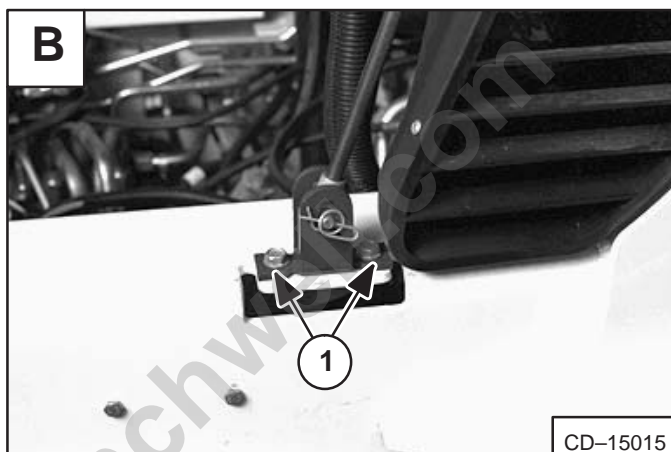
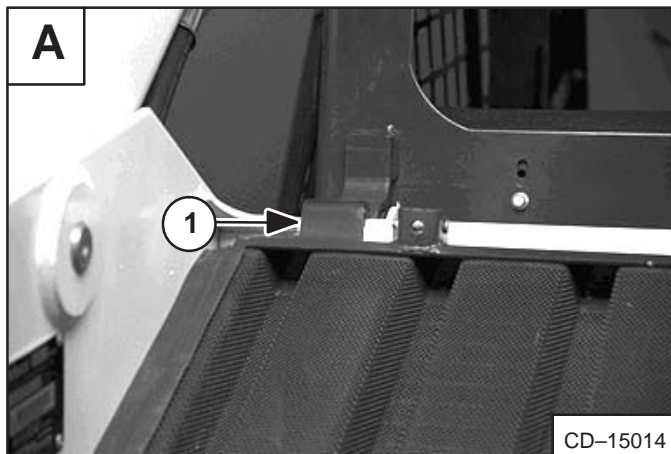

OPERATOR CAB GAS CYLINDER (Cont'd)

Disassembly And Assembly

**WARNING**

Cylinder contains high pressure gas. Do not open. Opening cylinder can release rod and cause injury or death.

W-2113-0288

Remove the clevis (Item 1) [A] and washer (Item 2) [A] from the end of the gas cylinder.

Remove the gas cylinder from the outer housing.

Assembly: Install a replacement cylinder inside the cylinder housing.

Apply a small amount of LOCTITE #242 adhesive on the threads of the cylinder rod [B].

Reinstall the washer and clevis on the cylinder rod.

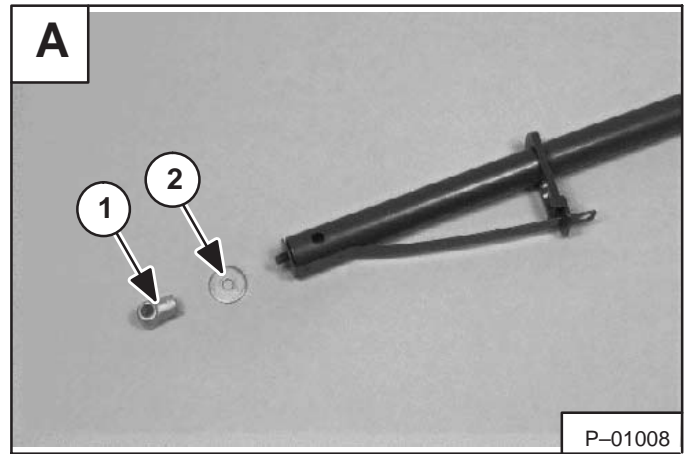

OPERATOR CAB

Removal And Installation

Remove the cab nut and holddown plate (Item 1) [A] (both sides).

Installation: Tighten the nut to 40–50 ft.-lbs. (54–68 Nm) torque.

Remove both gas cylinders (Page 5–7).

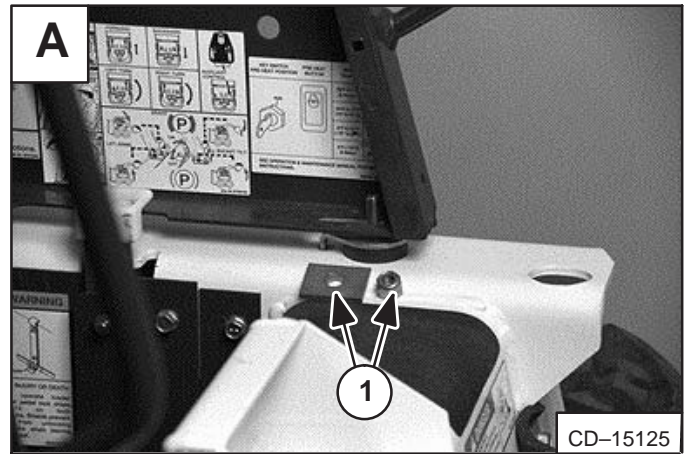

Disconnect the wiring harness connectors (Item 1) [B].

Disconnect the ground wire (Item 2) [B].

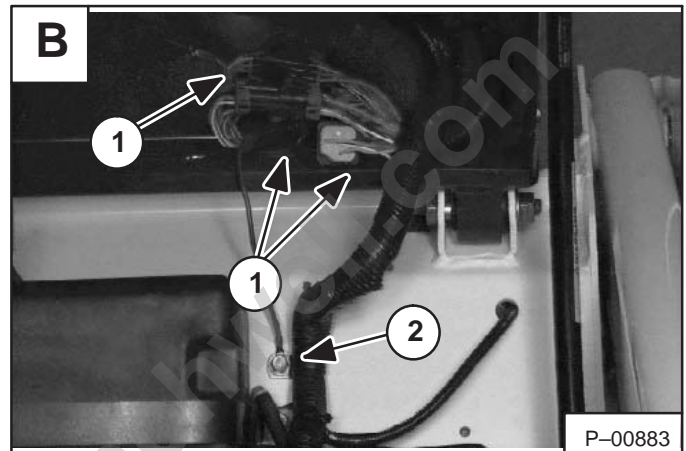

Connect a chain hoist to the operator cab grab handles and lower the operator cab when the gas cylinders are disconnected [C].



OPERATOR CAB (Cont'd)**Removal And Installation (Cont'd)**

Remove the nut (Item 1) [A] from the pivot bolt (both sides).

Installation: Tighten the pivot bolt and nut to 25–35 ft.-lbs. (34–47 Nm) torque.

Remove the pivot bolt (both sides).

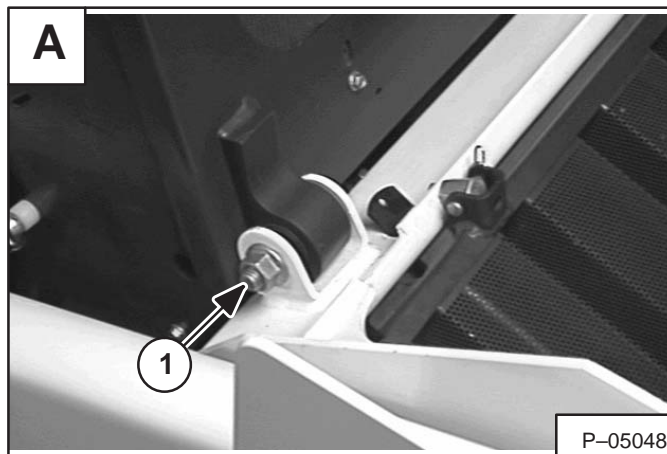

Move the operator cab forward a small amount for clearance at the pivot mounting brackets [B].

Install the pivot bolt, washer (one on each side) and nut (Item 1) [B] (both sides).

Install the sling under the pivot bolt and pivot of the operator cab [B].

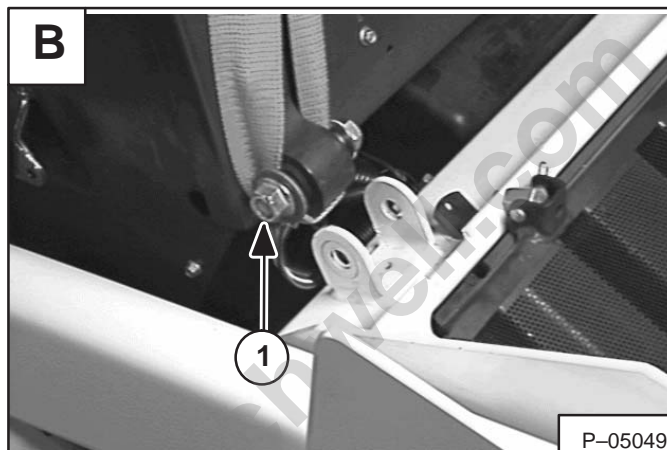

Connect the slings to a chain hoist and remove the operator cab from the loader [C].



BOB-TACH**Removal And Installation**

Tilt the Bob-Tach forward, so it is parallel to the floor. Put blocks approximately 3 inches thick under each side of the Bob-Tach (Item 1) [A]. Lower the Bob-Tach onto the blocks [A].

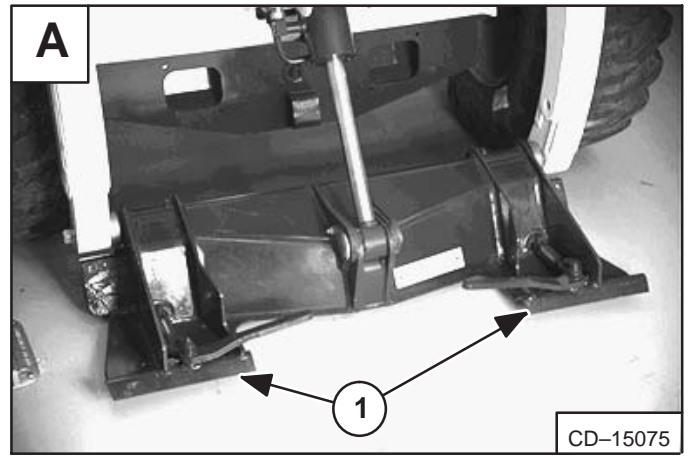

Remove the retainer bolt (Item 1) [B] from the pivot pin.

Installation: Tighten the retainer bolt to 18–20 ft.-lbs. (24–27 Nm) torque.

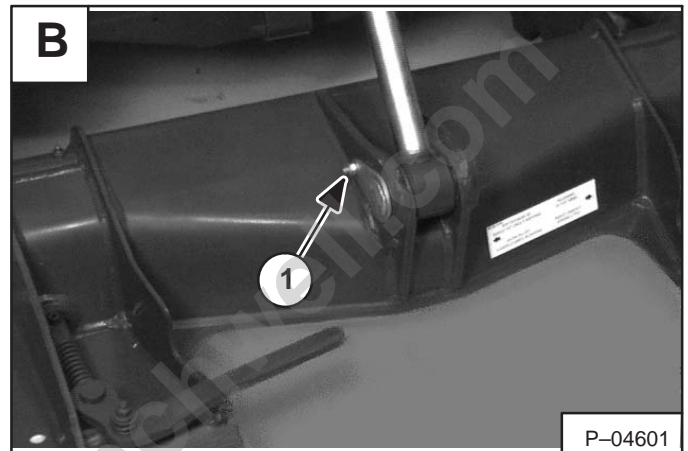

Remove the grease fitting from the pivot pin (Item 1) [C].

Remove the rod end pivot pin (Item 1) [C].

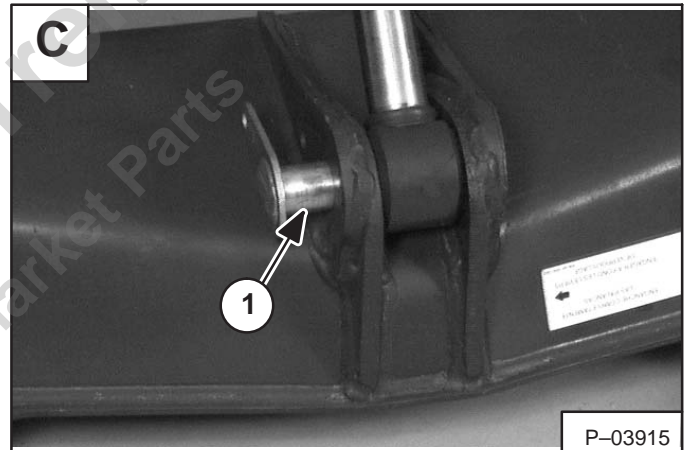

Remove the tilt cylinder rod end.

Remove the seals (Item 1) [D].

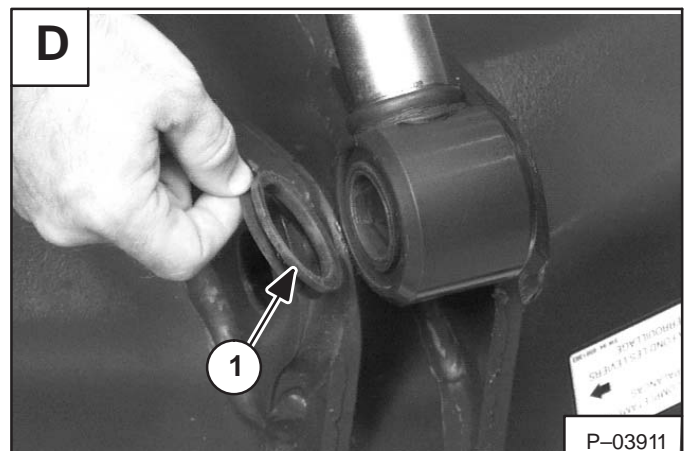

BOB-TACH (Cont'd)**Removal And Installation (Cont'd)**

Installation: Use two pieces of shim stock (light cardboard) to protect the seals during installation. Install the rod end of the tilt cylinder into the Bob-Tach **[A]**.

Be careful not to damage the seals during installation.

NOTE: Removal procedure is shown for the right side. Left side procedure is the same.

Remove the grease fitting (Item 1) **[B]** from the Bob-Tach frame for the pivot pin (both sides) **[C]**.

NOTE: The grease fitting must be removed to prevent the pivot pin from being hydraulic locked in the Bob-Tach frame.

Loosen the bolt (Item 2) **[B]** at the Bob-Tach pivot pin.

Installation: Tighten the bolt to 250–260 ft.-lbs. (339–353 Nm) torque.

Strike the head of the bolt (Item 2) **[B]** to push the pivot pin into the Bob-Tach frame.

Remove the bolt (Item 2) **[B]**.

Use a punch to push the pivot pin all the way into the Bob-Tach frame.

Installation: A longer bolt is necessary to install through lift arms into the pivot pin, to pull the pivot pin into the lift arms.

NOTE: Use tapered reamer MEL1233 to clean the tapered hole in the lift arms. The tapered hole must be clean and free of debris to provide a good contact surface for the pivot pin.

Remove the Bob-Tach frame from the lift arms **[C]**.

Remove the seal dust cup (Item 1) **[C]**.

Remove the rubber seal **[D]**.

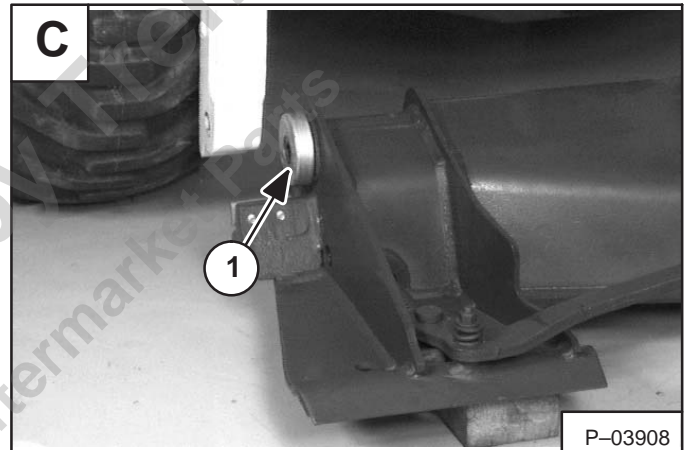
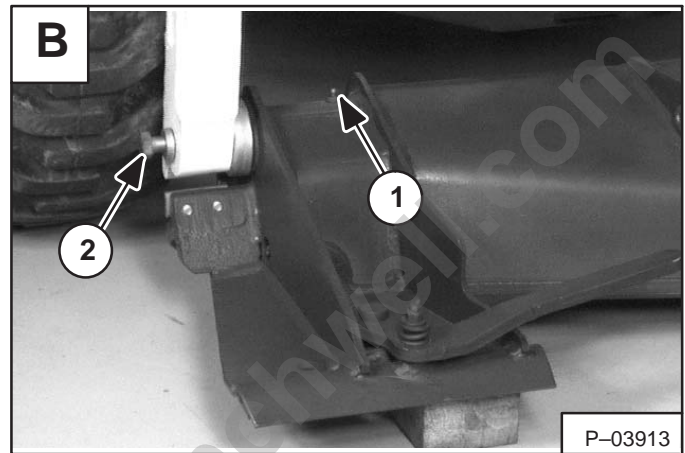
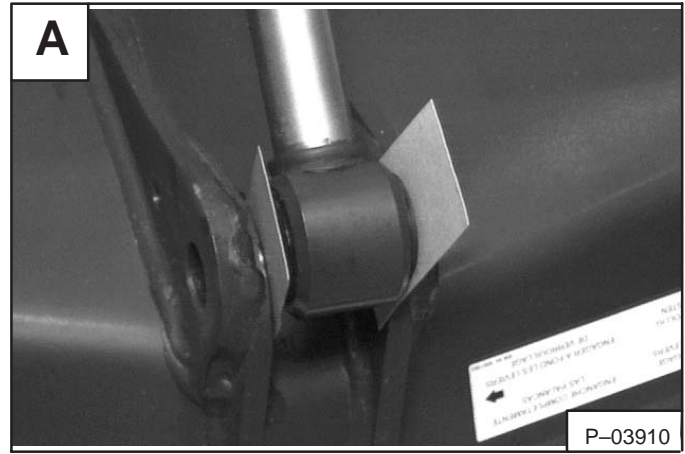

BOB-TACH (Cont'd)**Removal And Installation (Cont'd)**

Install the Bob-Tach mounting bolt (Item 1) [A] into the pivot pin (Item 2) [A]. Remove the pivot pin from the Bob-Tach frame.

Check for wear and damage. Replace the pivot pins as needed.

Installation: Push the pivot pin (Item 2) [A] into the Bob-Tach frame. Position the end of the pin flush with the end of the Bob-Tach bushing (Item 3) [A].

Reverse the removal procedure to install the Bob-Tach.

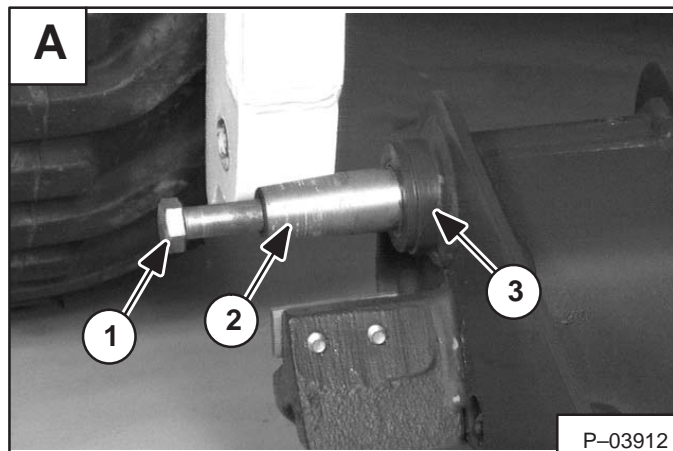
**Bob-Tach Lever And Wedge**

Use the following procedure to remove and install the Bob-Tach lever (Item 1) [B], spring and wedge:

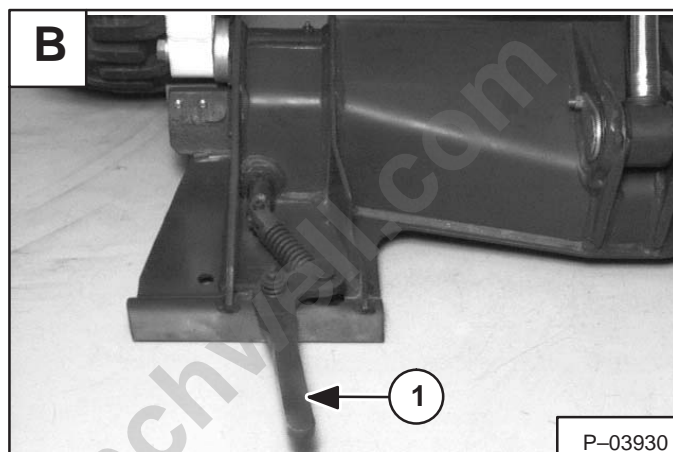

Remove the lever mounting bolt and nut (Item 1) [C], washer (Item 2) [C] and spring (Item 3) [C].

Installation: Tighten the nut to 25–28 ft.-lbs. (34–38 Nm) torque.

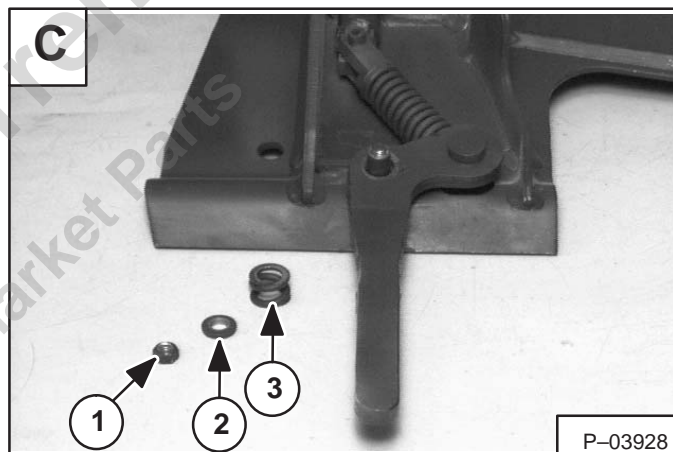

Remove the Bob-Tach lever (Item 1) [D].

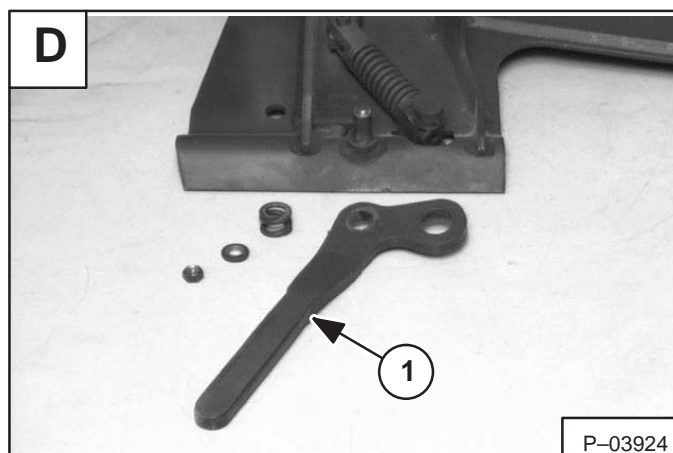

BOB-TACH (Cont'd)**Bob-Tach Lever And Wedge (Cont'd)**

Using a punch and hammer, remove the roll pin (Item 1) [A] from the Bob-Tach wedge and spring, bolt and clevis assembly.

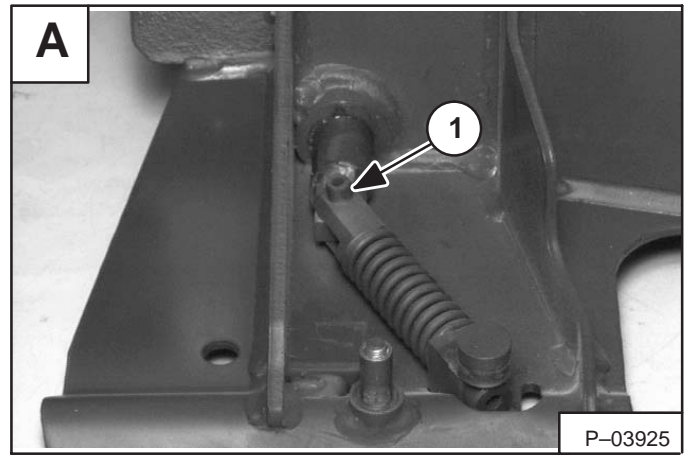

Remove the spring, bolt and clevis assembly (Item 1) [B].

Remove the wedge (Item 2) [B] from the Bob-Tach frame.

Always replace bent or broken wedges.

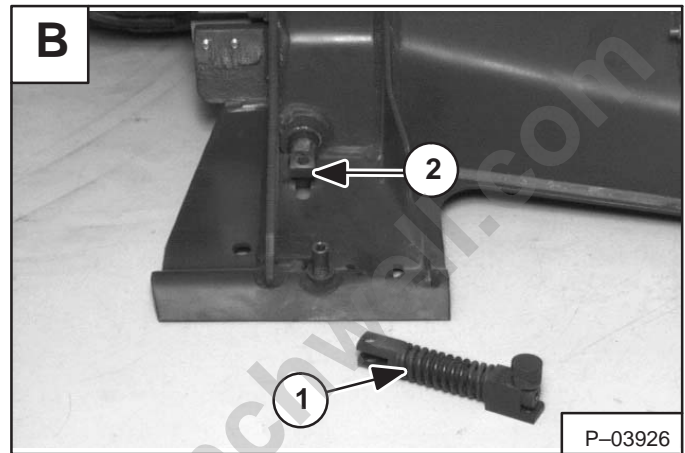

If the bolt (Item 1) [C], handle pivot (Item 2) [C], spring (Item 3) [C] or clevis (Item 4) [C] are damaged, put the assembly in the vise. Loosen and remove the bolt (Item 1) [C] with a 5/16 inch allen wrench.

Replace the worn or damaged parts as needed.

Reverse the removal procedure to install the Bob-Tach Lever and Wedge.

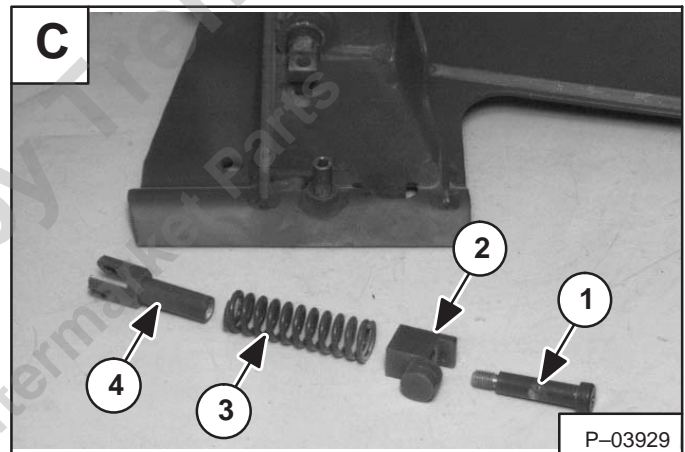
**Bob-Tach Stops**

Remove and replace the Bob-Tach stop (Item 1) [D] (both sides) if worn or damaged.

NOTE: The Bob-Tach stop (Item 1) [D] must contact the lift arm at the same time the tilt cylinder reaches full extension. Use available shims to adjust the Bob-Tach stop and tilt cylinder sequence as closely as possible.

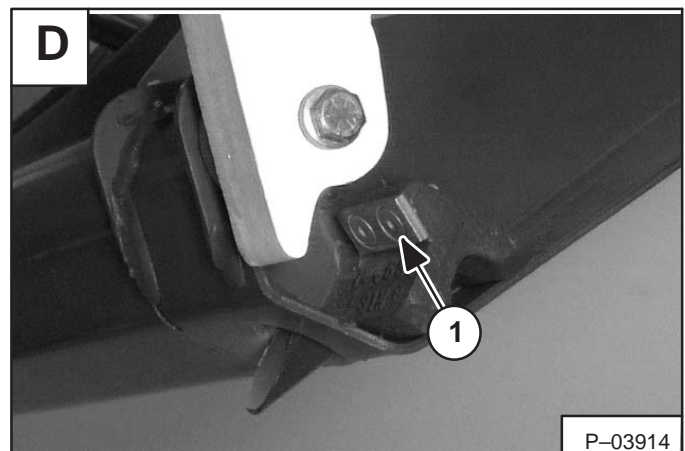

LIFT ARMS

Removal And Installation

Roll the Bob-Tach (Item 1) [A] fully forward.

Stop the engine.

Remove the Bob-Tach (Item 1) [A] from the lift arms (Page 5–7).

Install the slings (Item 2) [A] on the lift arms.

Connect a chain hoist to the slings [A].

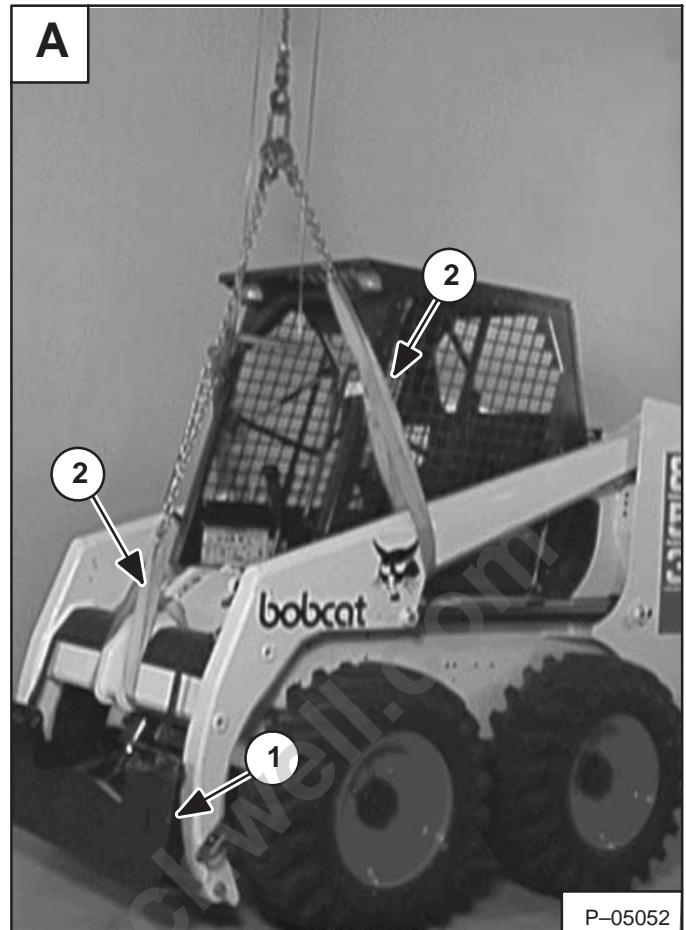

Remove the retainer bolt and nut (Item 1) [B] from the rod end lift cylinder pivot pin (both sides).

Installation: Tighten the retainer bolt and nut to 18–20 ft.-lbs. (24–27 Nm) torque.

Raise the lift arms with the chain hoist so there is enough clearance to remove the rod end pivot pin.

Remove the lift cylinder rod end pivot pin (both sides).

Lower the lift arms.

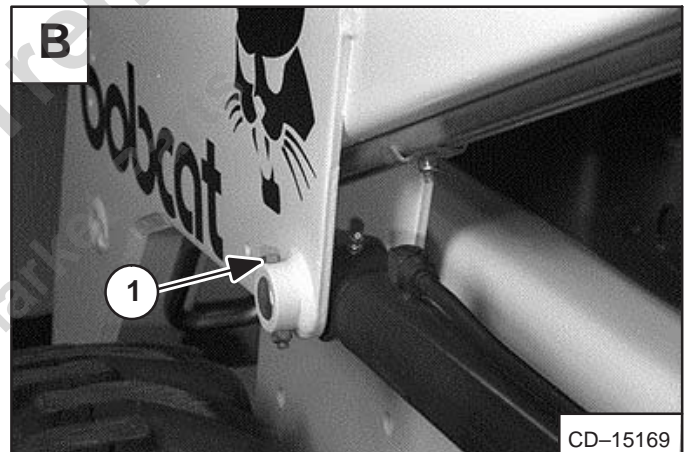

Disconnect the auxiliary hydraulic tubelines and hoses (Item 1) [C] if so equipped (both sides).

Remove the retainer bolt and nut (Item 2) [C] from the lift arm pivot pin.

Installation: Tighten the retainer bolt and nut to 18–20 ft.-lbs. (24–27 Nm) torque.

Remove the lift arm pivot pin.

Raise the lift arms with the chain hoist and remove from the loader frame.

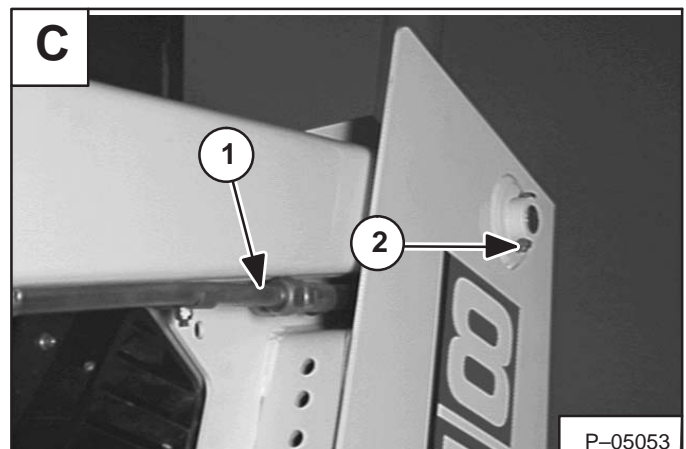

REAR GRILL**Removal And Installation****WARNING**

Cylinder contains high pressure gas. Do not open. Opening cylinder can release rod and cause injury or death.

W-2113-0288

Raise the rear grill.

Support the rear grill.

Remove the nut (Item 1) **[A]** to disconnect the gas cylinder from the rear grill.

Lower the rear grill.

Remove the cotter pin (Item 1) **[B]** from the pivot pin (both sides).

Remove the pivot pin (Item 1) **[C]** (both sides).

Remove the rear grill from the loader **[D]**.

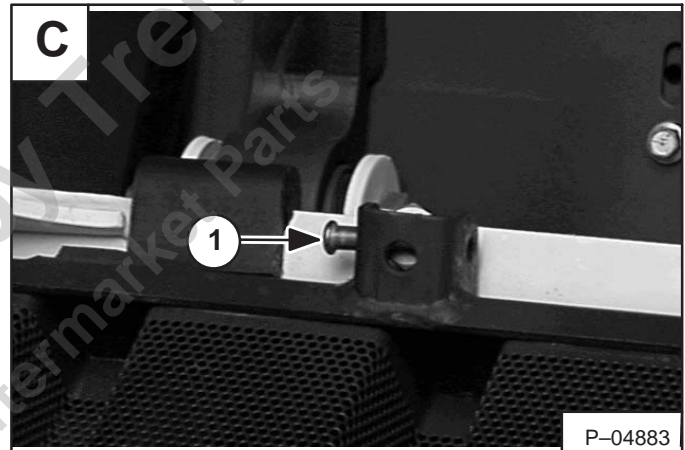
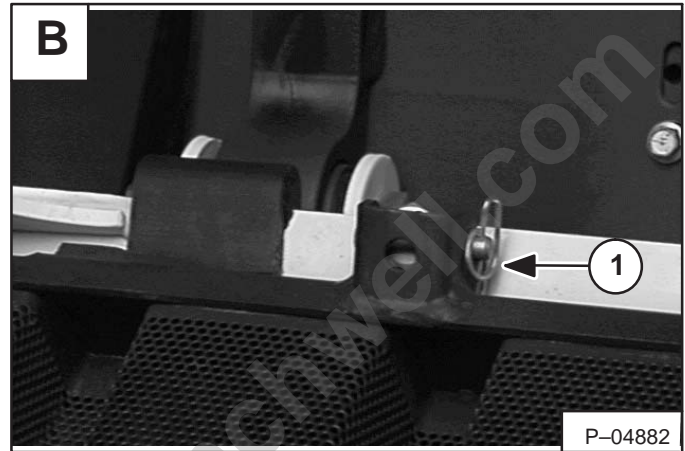
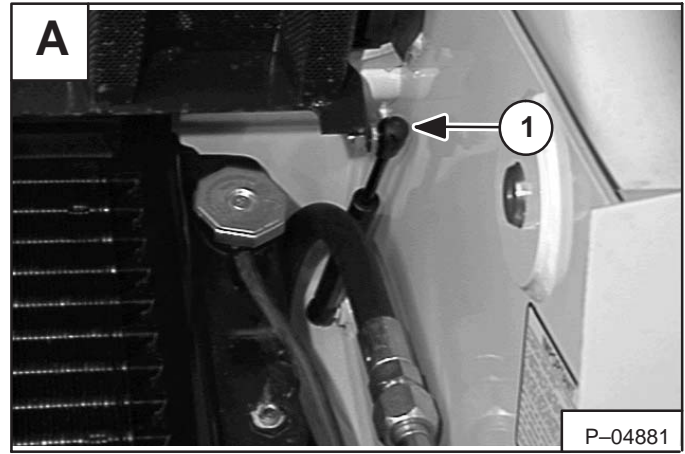

REAR DOOR

Removal And Installation

Open the rear door, disconnect the wiring harness connector (Item 1) [A].

Remove the nuts (Item 2) [A] from the pivot bolts.

Installation: Tighten the bolts and nuts to 25–28 ft.-lbs. (34–38 Nm) torque.

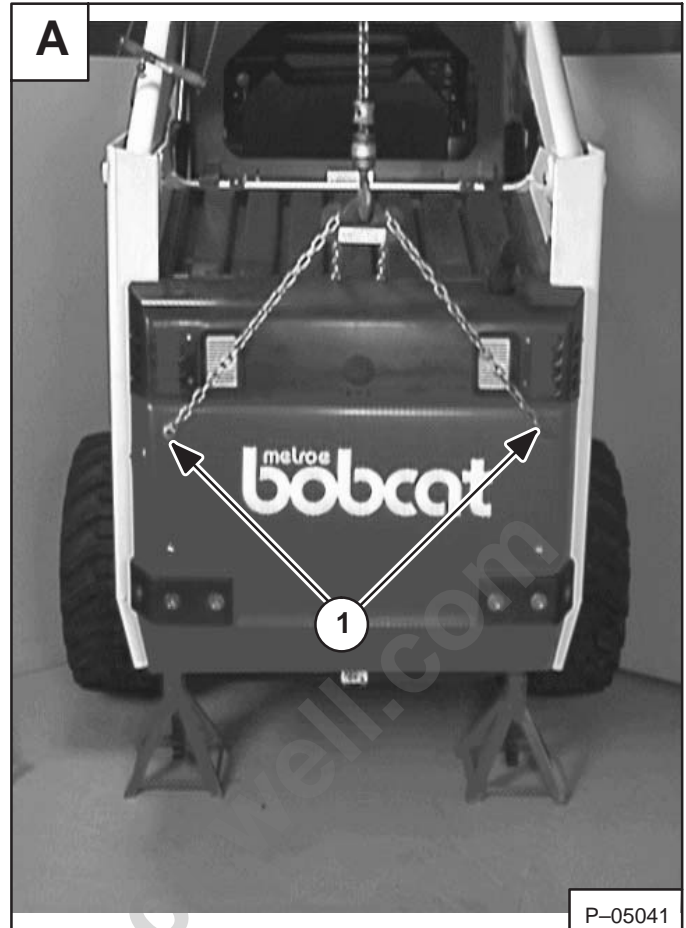

P-05041

Connect a 1/4 inch chain to the rear door using two bolts (Item 1) [B].

Inside the rear door, secure the chain with washers and nuts.

Connect a chain hoist to the chain.

Remove the rear door pivot bolts.

Lift the rear door away from the loader frame and put the door flat on the floor.

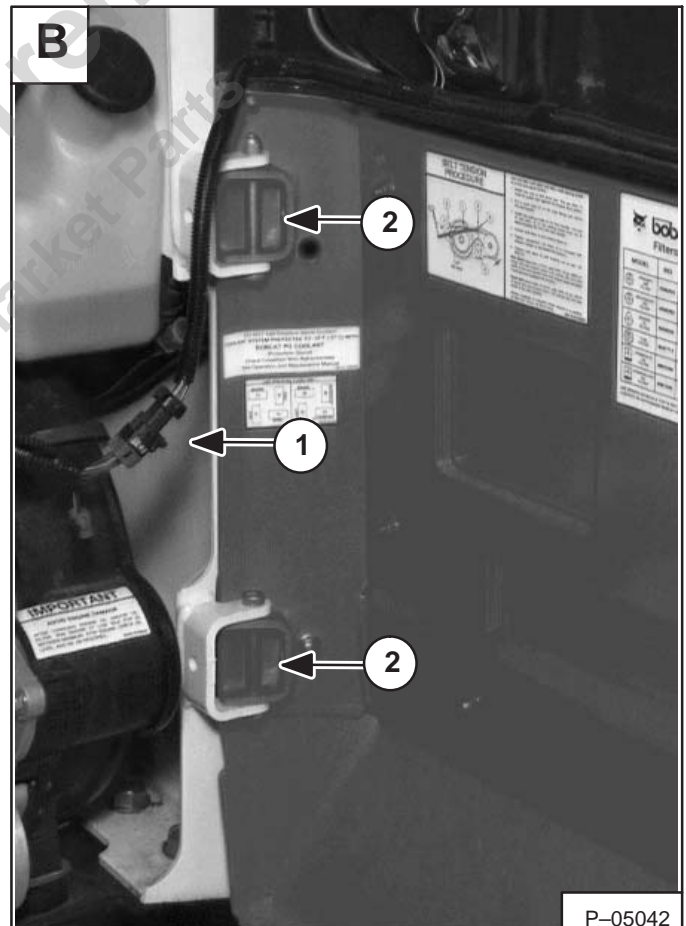

P-05042

REAR DOOR (Cont'd)**Hood Removal And Installation**

Remove the rear lights harness from the rear door hood if so equipped.

Remove the mounting bolts from the rear door hood (Item 1) [A].

Installation: Tighten the hood mounting bolts to 25–28 ft.-lbs. (34–38 Nm) torque.

Remove the hood from the rear door.

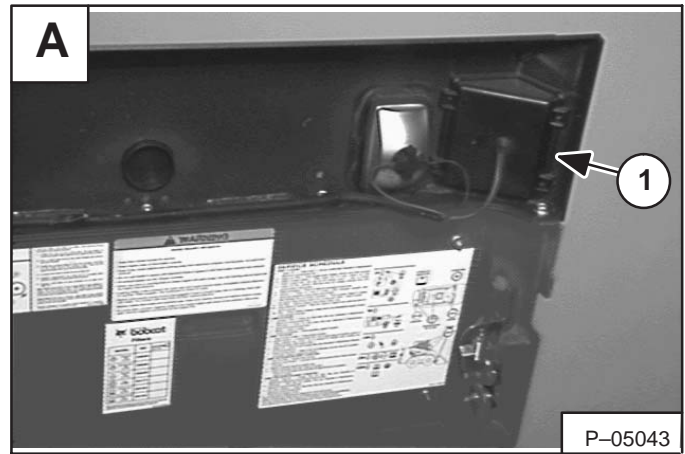

P-05043

Bumper Removal And Installation

Remove the rear bumper mounting bolts (Item 1) [B] with a 7/32 inch allen wrench.

Installation: Tighten the mounting bolts to 180–200 in.-lbs. (21–23 Nm) torque.

Remove the bumper (Item 2) [B] from the rear door.

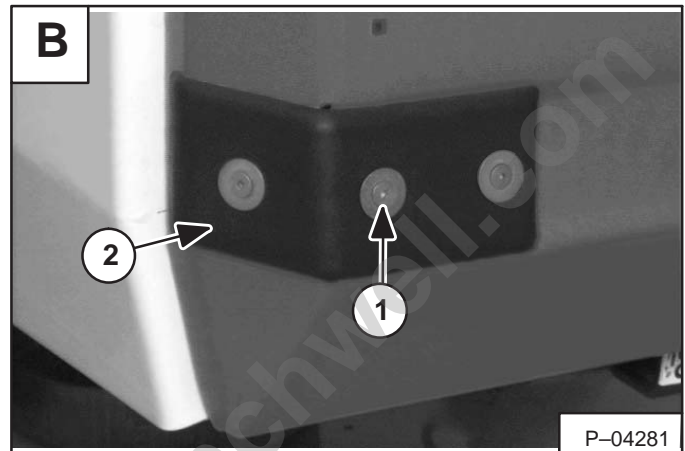

P-04281

Door Latch Removal And Installation

Remove the door latch mounting bolts (Item 1) [C] from the door latch mechanism.

Installation: Tighten the mounting bolts to 80–90 in.-lbs. (9–10 Nm) torque.

Remove the latch and handle mechanisms from the rear door.

Door Latch And Catch Adjustment

⚠ WARNING

AVOID INJURY

Never service or adjust the machine when the engine is running unless instructed to do so in the manual.

W-2012-0290

The door catch (Item 1) [D] can be adjusted side to side for alignment with the door latch.

The door latch mechanism (Item 1) [C] can be adjusted forward or backward for alignment with the door catch.

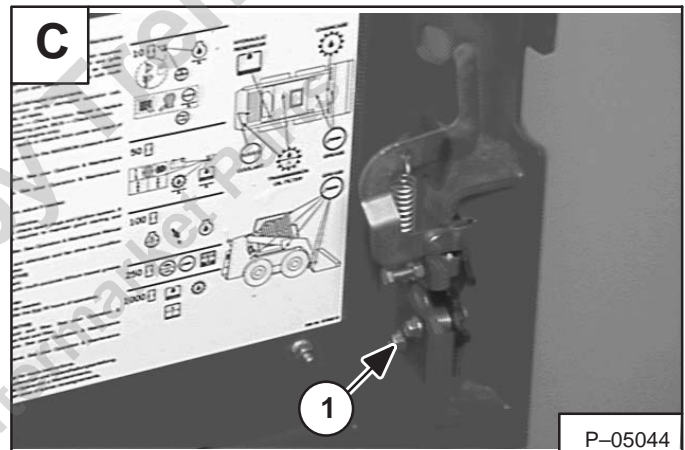

P-05044

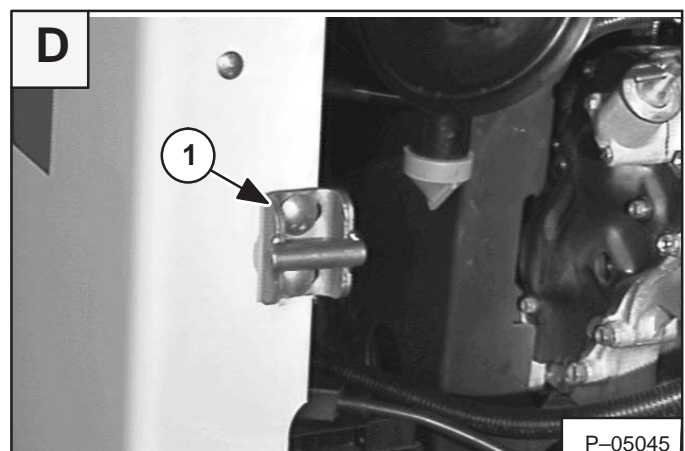

P-05045

FUEL TANK**Removal And Installation**

Remove the cover (Item 1) [A] which is installed over the drain plug.

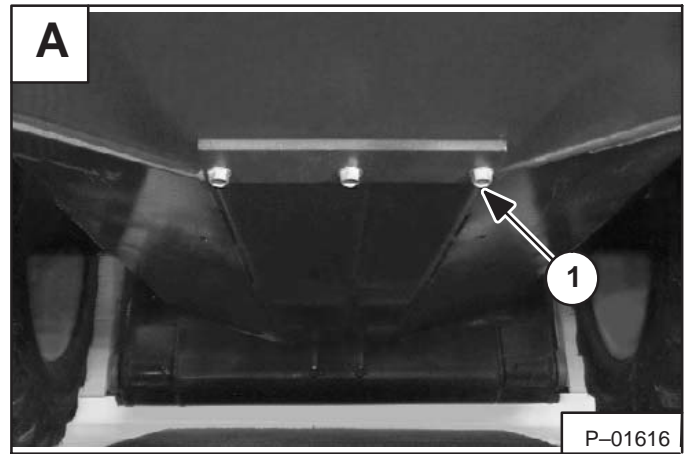

Remove the drain plug (Item 1) [B].

Drain the fuel into a container.

Check the drain plug and replace if necessary.

Remove the engine/hydrostatic pump assembly from the loader (Page 7-1).

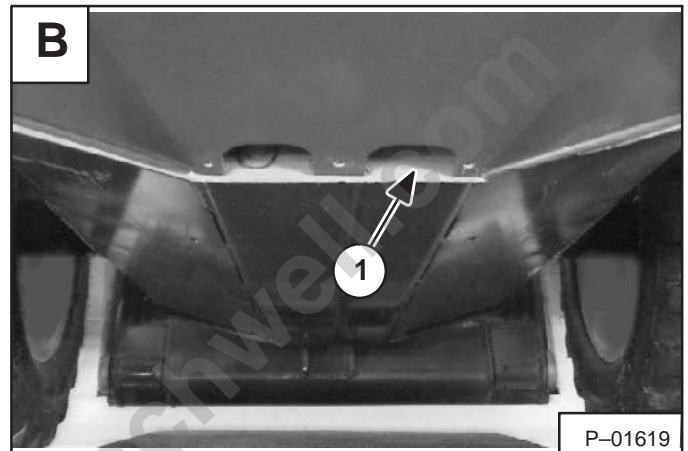

Disconnect the fuel fill hose (Item 1) [C].

Disconnect the tank vent hose (Item 2) [C].

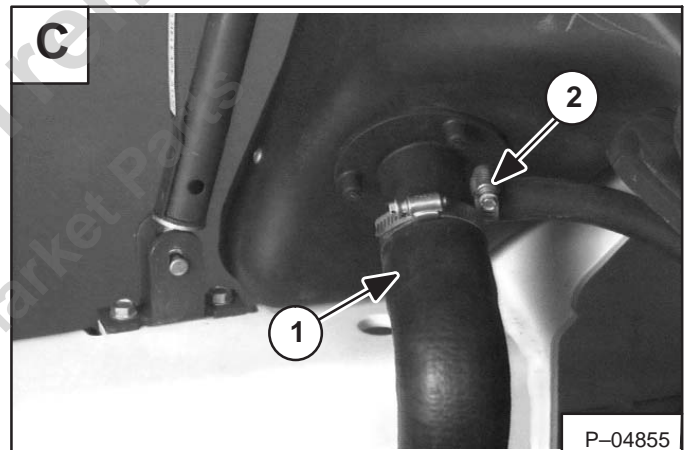

Remove the bolts (Item 1) [D] from the battery holddown plate.

Remove the battery holddown plate from the loader.

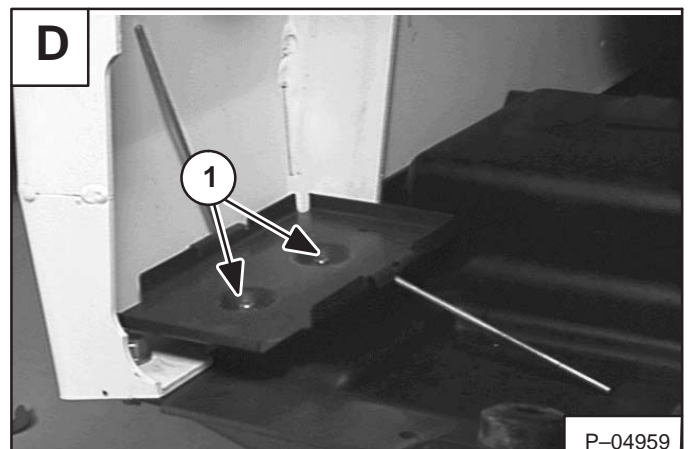

FUEL TANK (Cont'd)

Removal And Installation (Cont'd)

Remove the mounting plate (Item 1) [A] for the battery holddown plate.

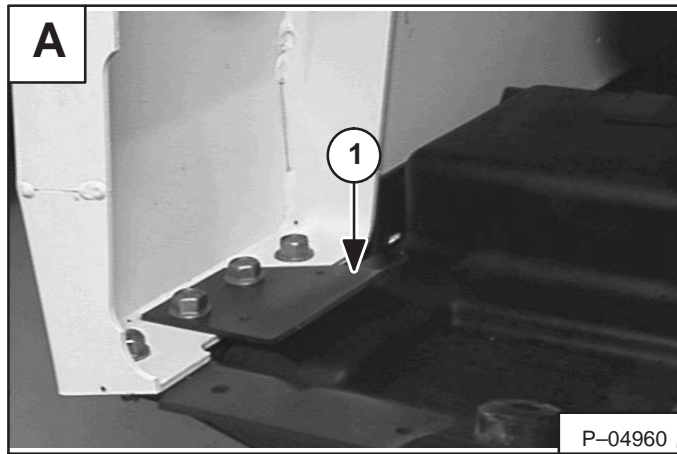

P-04960

Lift the fuel tank and remove it from the loader frame [B].

Fuel Level Sender

Loosen the fuel level sender (Item 1) [B].

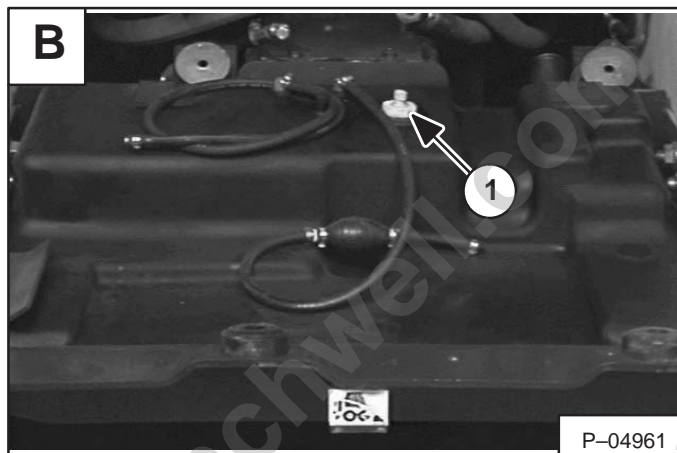

P-04961

Remove the fuel level sender from the fuel tank [C].

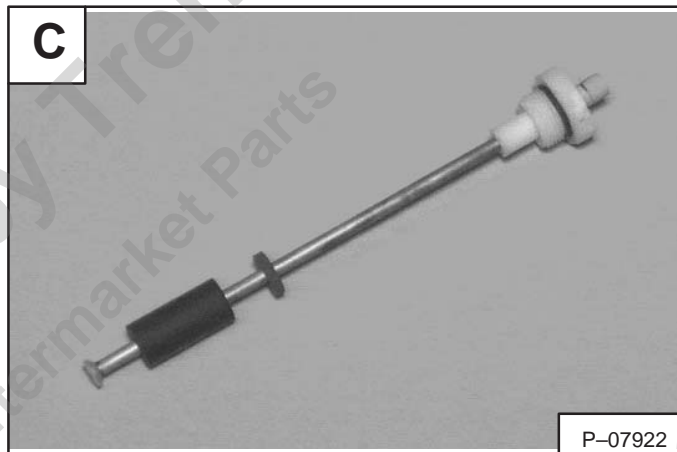

P-07922

Inlet Screen

The inlet screen (Item 1) [D] is located at fuel tank fill neck.

Disconnect the fuel fill hose.

Remove the inlet screen (Item 1) [D].

Wash the screen in clean solvent.

Dry the screen and check for damage. Replace as needed.

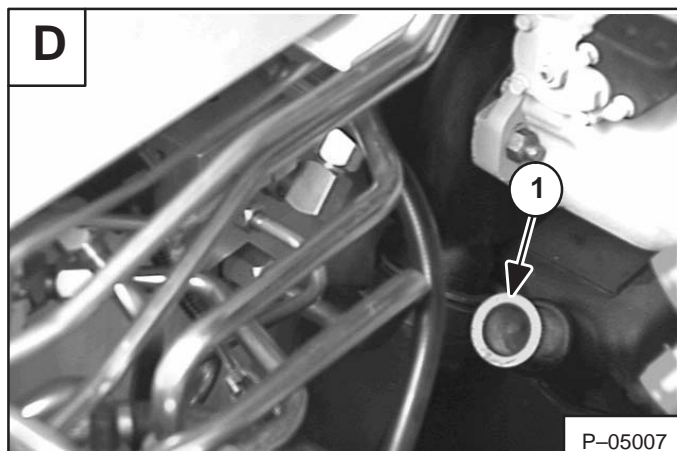

P-05007

ELECTRICAL SYSTEM

	Page Number
ALTERNATOR	
Assembly	6-15
Alternator Output Test	6-10
Alternator Regulator Test	6-11
Disassembly	6-13
Rectifier (Diode) Test	6-10
Rectifier Continuity (Diode) Test	6-14
Removal and Installation	6-12
Rotor Continuity Test	6-14
Rotor Ground Test	6-14
Stator Continuity Test	6-13
Stator Ground Test	6-13
BATTERY	
Removal And Installation	6-7
Servicing The Electrical System	6-8
Using A Booster Battery (Jump Starting)	6-9
ELECTRICAL SYSTEM INFORMATION	
Description	6-6
Fuse Location	6-6
FRONT LIGHTS	
Removal And Installation	6-23
STANDARD INSTRUMENT PANEL	
Removal And Installation	6-22
STARTER	
Checking The Starter	6-16
Cleaning And Inspection	6-21
Disassembly And Assembly	6-19
Parts Identification	6-18
Removal And Installation	6-17
STEERING LEVER CONTROL HANDLE (Early Series)	
Disassembly And Assembly	6-24
TROUBLESHOOTING	
Chart	6-5

**ELECTRICAL
SYSTEM**



Provided for Free by www.youfixthis.com
Shop Aftermarket Parts at www.frenchwell.com

WIRING SCHEMATICS 853

853 BOSS - WIRING SCHEMATIC
S/N 508411001-11010
(Printed June 1999)
MC2561

853 BOSS - WIRING SCHEMATIC
S/N 508411011-11353
(Printed June 1999)
MC2562

853 BOSS - WIRING SCHEMATIC
S/N 508411354-11714
S/N 509711001-11094
(Printed June 1999)
MC2566

853 BOSS - WIRING SCHEMATIC
S/N 508411715-12360
S/N 509711095-11308
(Printed June 1999)
MC2572

853 BOSS - WIRING SCHEMATIC
S/N 508412361-12460
S/N 509711309-11334
(Printed June 1999)
MC2567

853 BOSS - WIRING SCHEMATIC
S/N 508412461-15055
S/N 509711335-15096
S/N 510250001-50161
S/N 510375001-75092
(Printed June 1999)
MC2563

853 BOSS - WIRING SCHEMATIC
S/N 508415056-15187
S/N 509715097-15221
S/N 510250162-50448
S/N 510375093-75213
(Printed June 1999)
MC2564

853 BOSS - WIRING SCHEMATIC
S/N 508415188-17999
S/N 509715222-17999
S/N 510250449 AND ABOVE
S/N 510375214 AND ABOVE
S/N 512815001-15999
(Printed June 1999)
MC2571

853 WITHOUT BOSS - WIRING SCHEMATIC
S/N 510125001-25239
(Printed June 1999)
MC2568

853 WITHOUT BOSS - WIRING SCHEMATIC
S/N 510125240-26110
(Printed June 1999)
MC2569

853 WITHOUT BOSS - WIRING SCHEMATIC
S/N 510126111 AND ABOVE
S/N 512811001-14999
(Printed June 1999)
MC2570

WIRING SCHEMATICS (CONTINUED)
853

OPTIONS

853 - WIRING SCHEMATIC
ATTACHMENT CONTROL OPTION
S/N 508415001-17999
S/N 509715001-17999
S/N 510125001 AND ABOVE
S/N 510250001 AND ABOVE
S/N 510375001 AND ABOVE
S/N 512811001-15999
(Printed June 1999)
MC2574

853 - WIRING SCHEMATIC
OPTIONS
S/N 508411001-17999
S/N 509711001-17999
S/N 510125001 AND ABOVE
S/N 510250001 AND ABOVE
S/N 510375001 AND ABOVE
S/N 512811001-15999
(Printed June 1999)
MC2565

Provided for Free by Trenchwell.com
Shop Aftermarket Parts

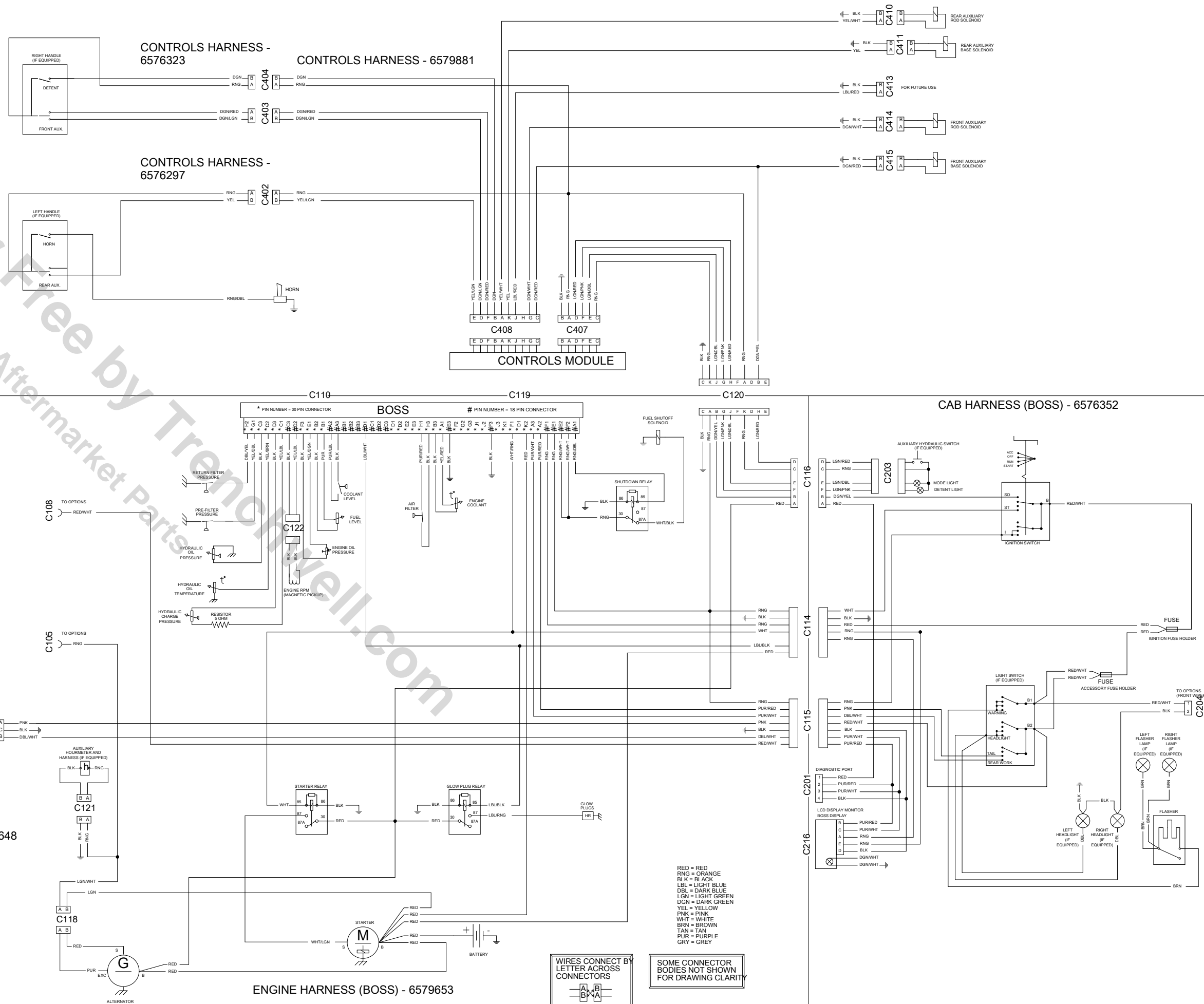

Provided for Free by TrendWell.com

Shop Aftermarket Parts

Provided for Free by TrenchWell.com

Shop Aftermarket Parts

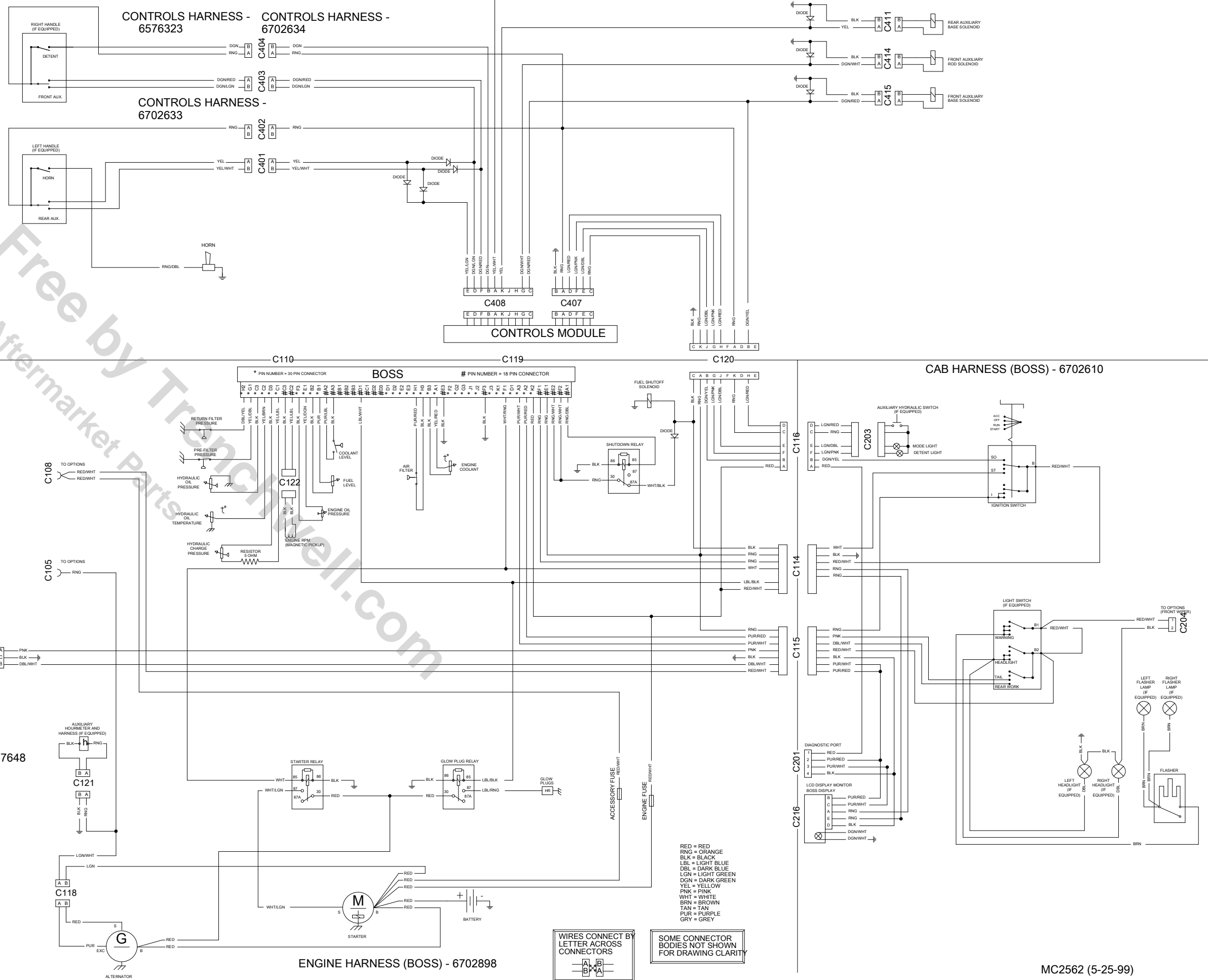

853 BOSS - WIRING SCHEMATIC

S/N 508411715-12360
S/N 509711095-11308
(Printed June 1999)
MC2572

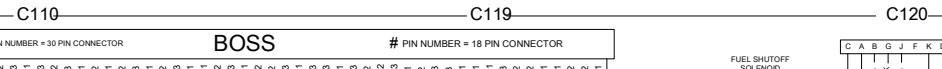
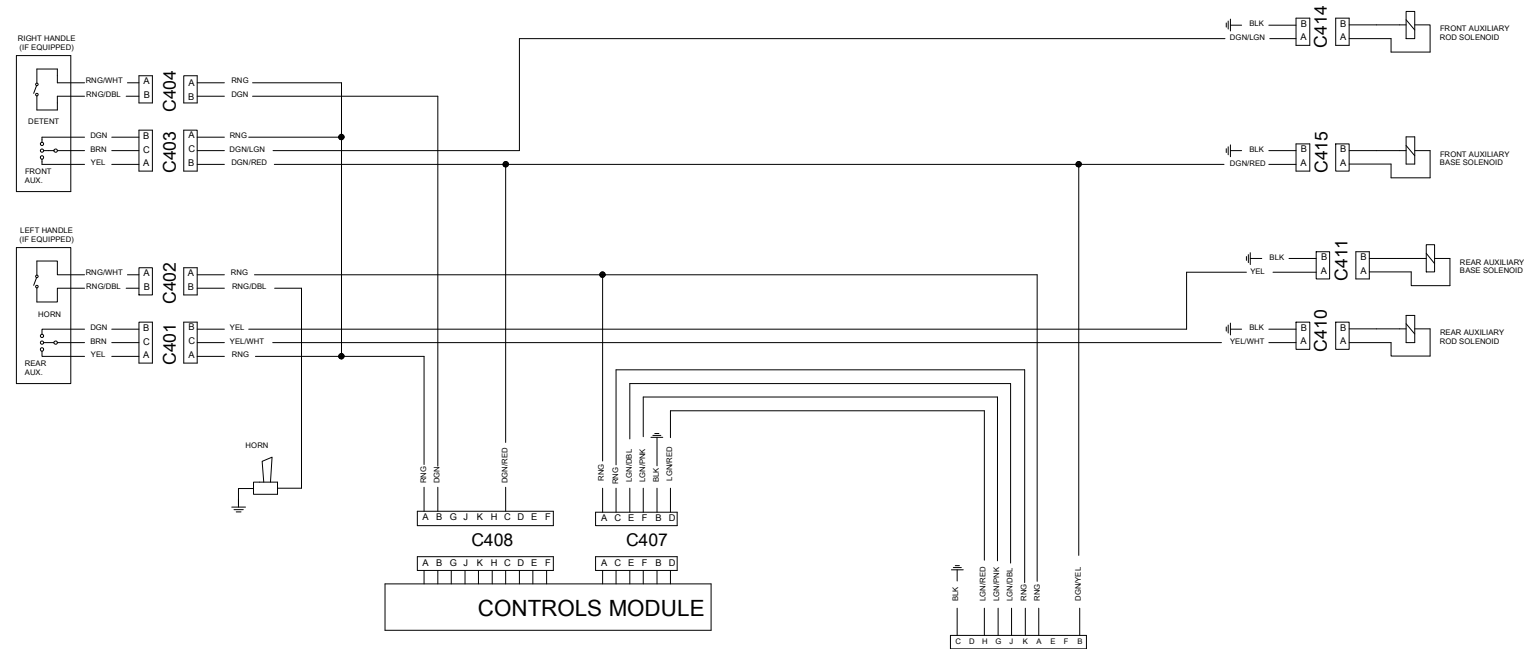

CAB HARNESS (BOSS) - 6702610

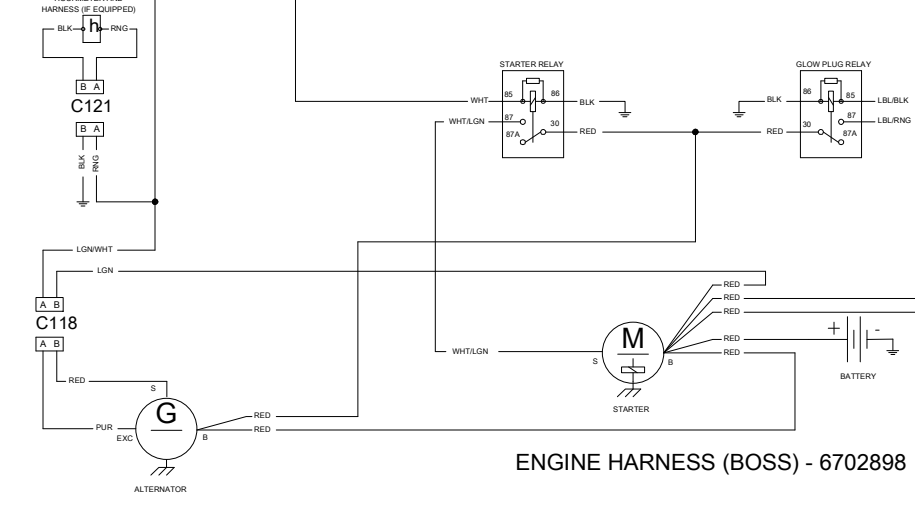
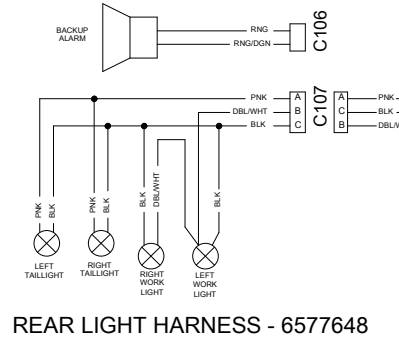
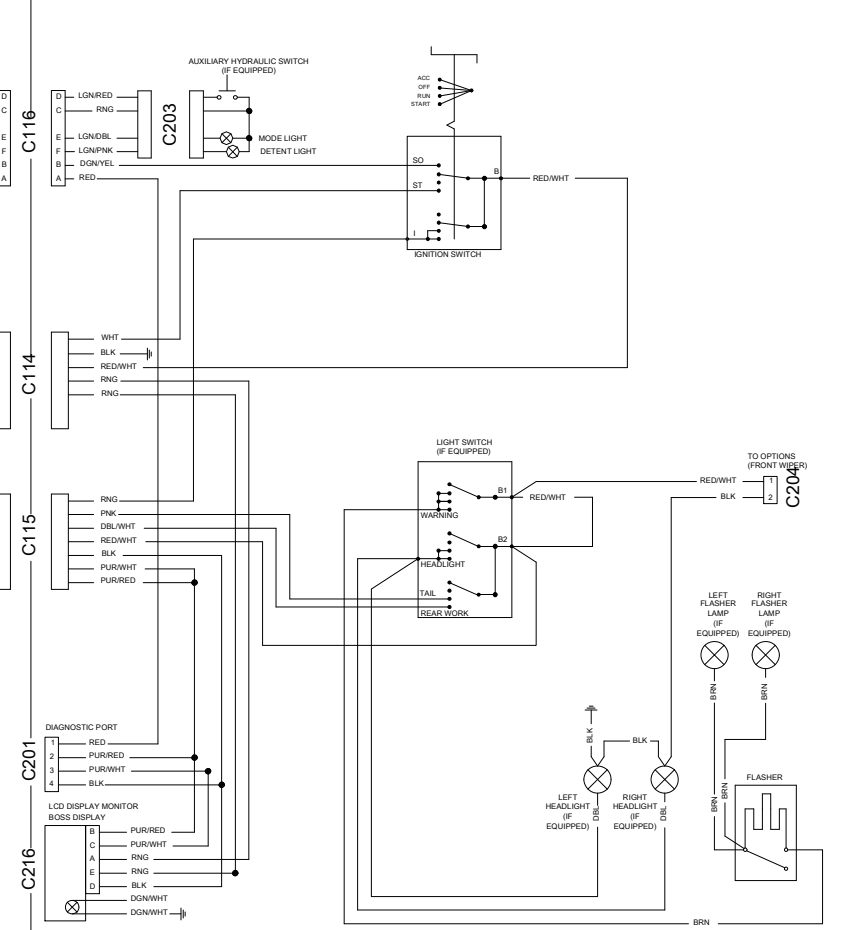

RED = RED
RNG = ORANGE
BLK = BLACK
LBL = LIGHT BLUE
DBL = DARK BLUE
LGN = LIGHT GREEN
DGN = DARK GREEN
YEL = YELLOW
PNK = PINK
WHT = WHITE
BRN = BROWN
TAN = TAN
PUR = PURPLE
GRY = GREY

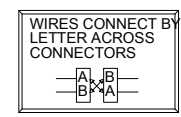

SOME CONNECTOR BODIES NOT SHOWN FOR DRAWING CLARITY

853 BOSS - WIRING SCHEMATIC

S/N 508412361-12460
S/N 509711309-11334
(Printed June 1999)
MC2567

CONTROLS HARNESS - 6703878

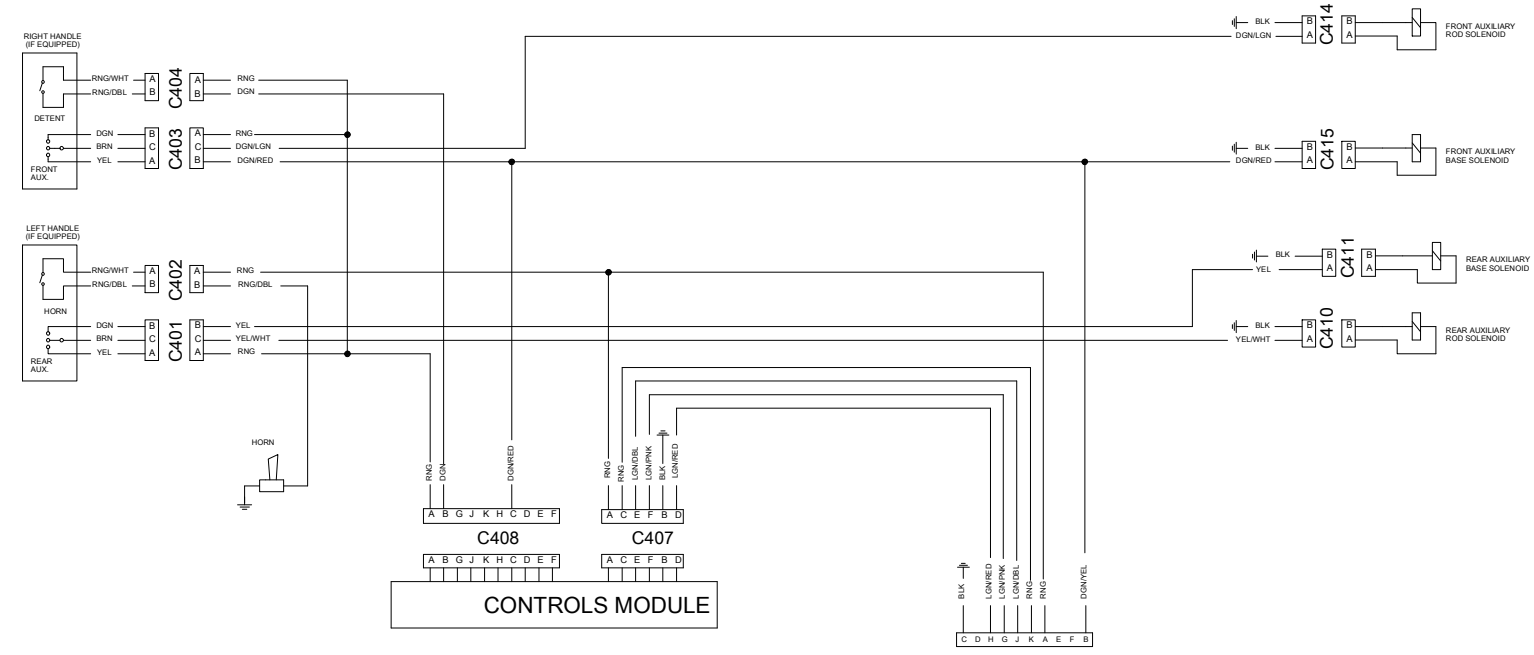

CAB HARNESS (BOSS) - 6704407

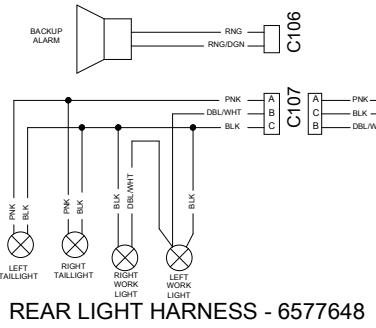
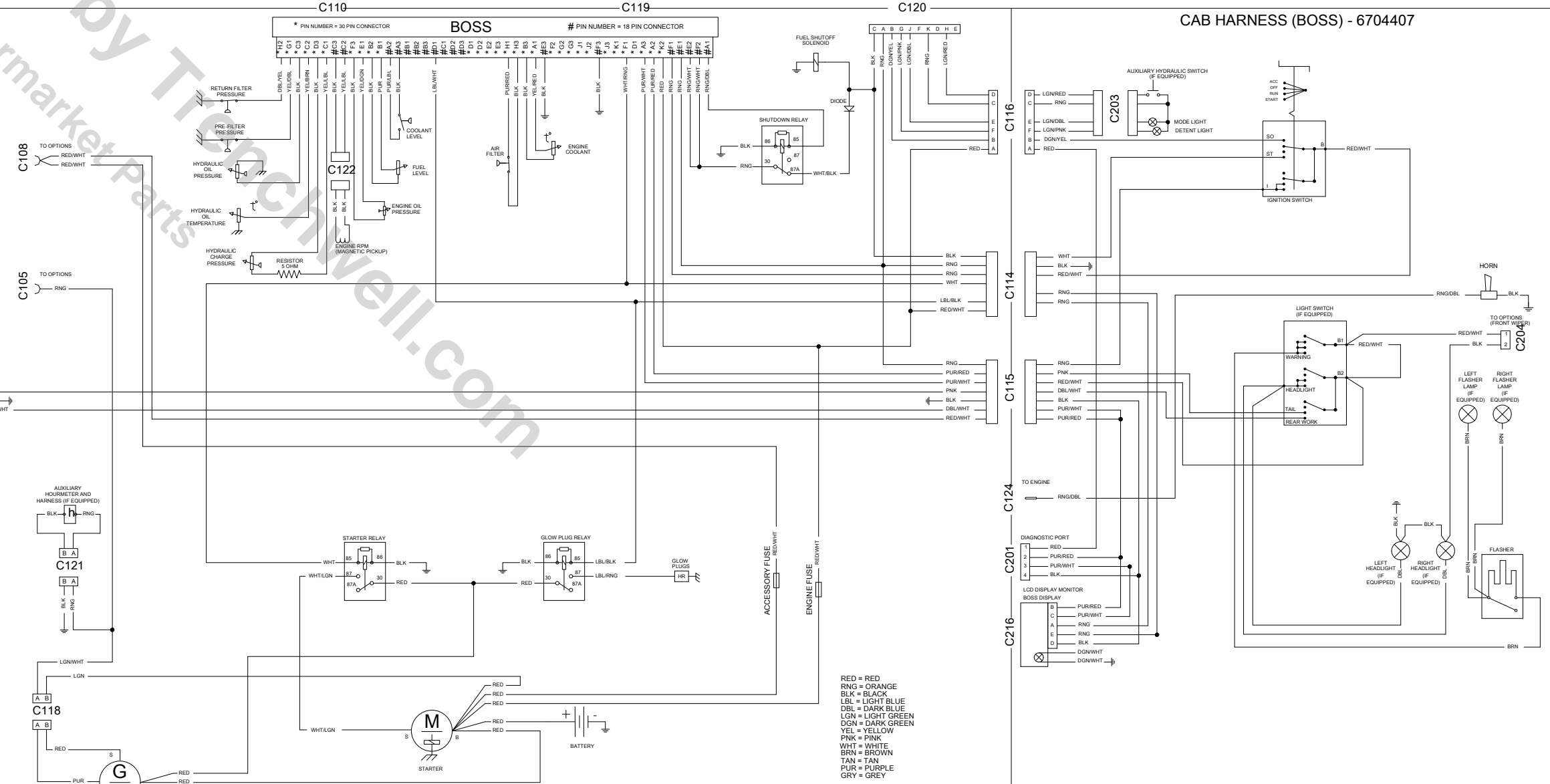

ENGINE HARNESS (BOSS) - 6702898

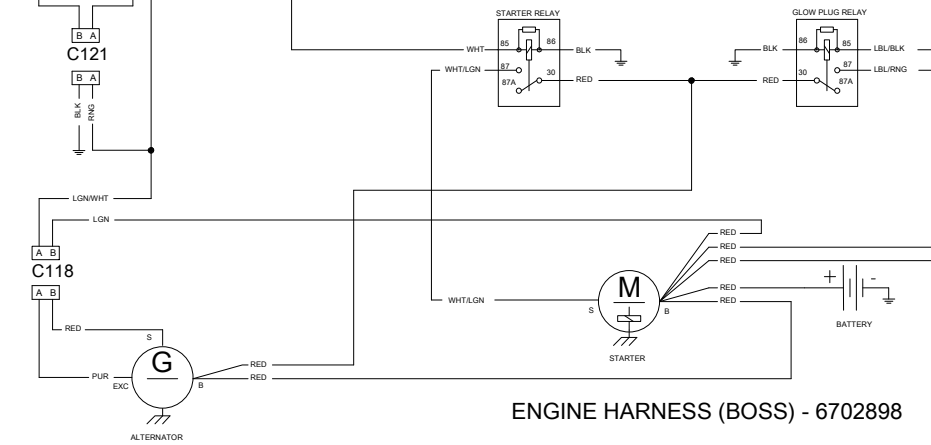

WIRES CONNECT BY LETTER ACROSS CONNECTORS

SOME CONNECTOR BODIES NOT SHOWN FOR DRAWING CLARITY

853 BOSS - WIRING SCHEMATIC

S/N 508412461-15055
S/N 509711335-15096
S/N 510250001-50161
S/N 510375001-75092
(Printed June 1999)
MC2563

CONTROLS HARNESS - 6703878

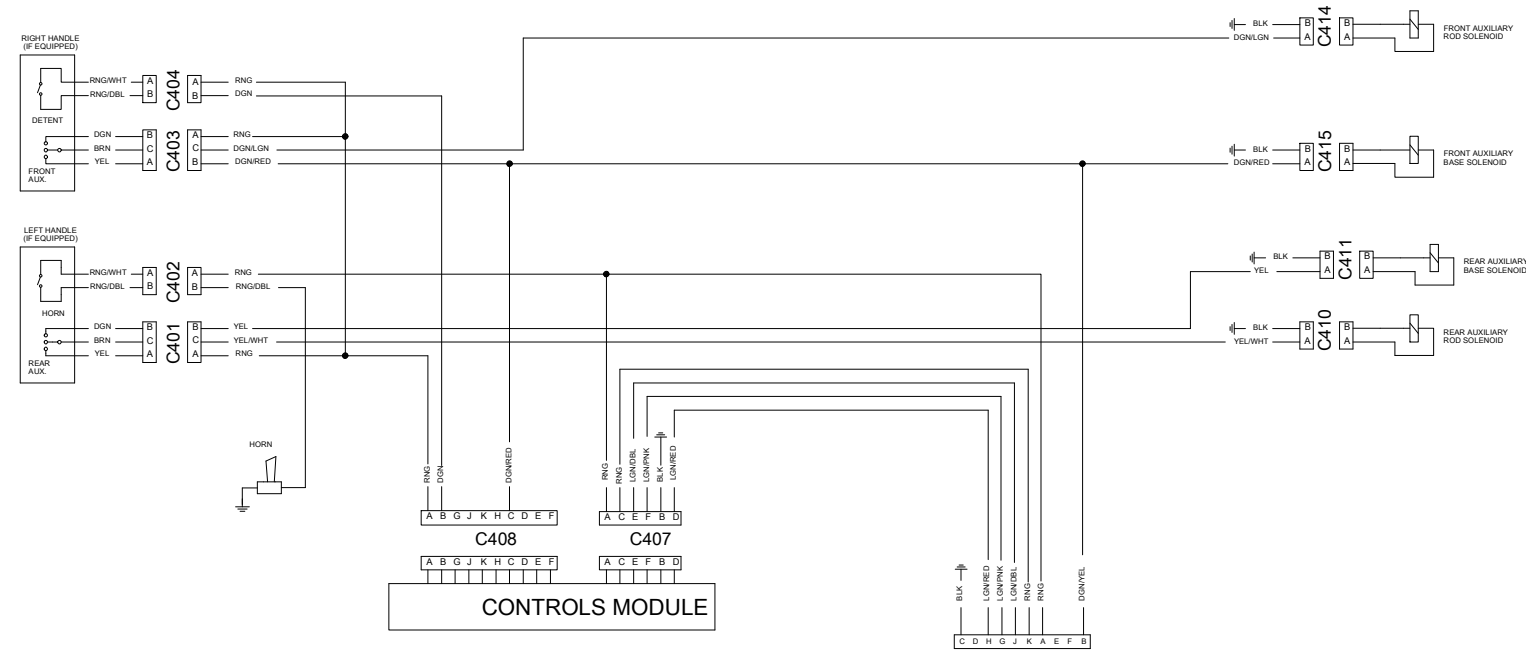

CAB HARNESS (BOSS) - 6704407

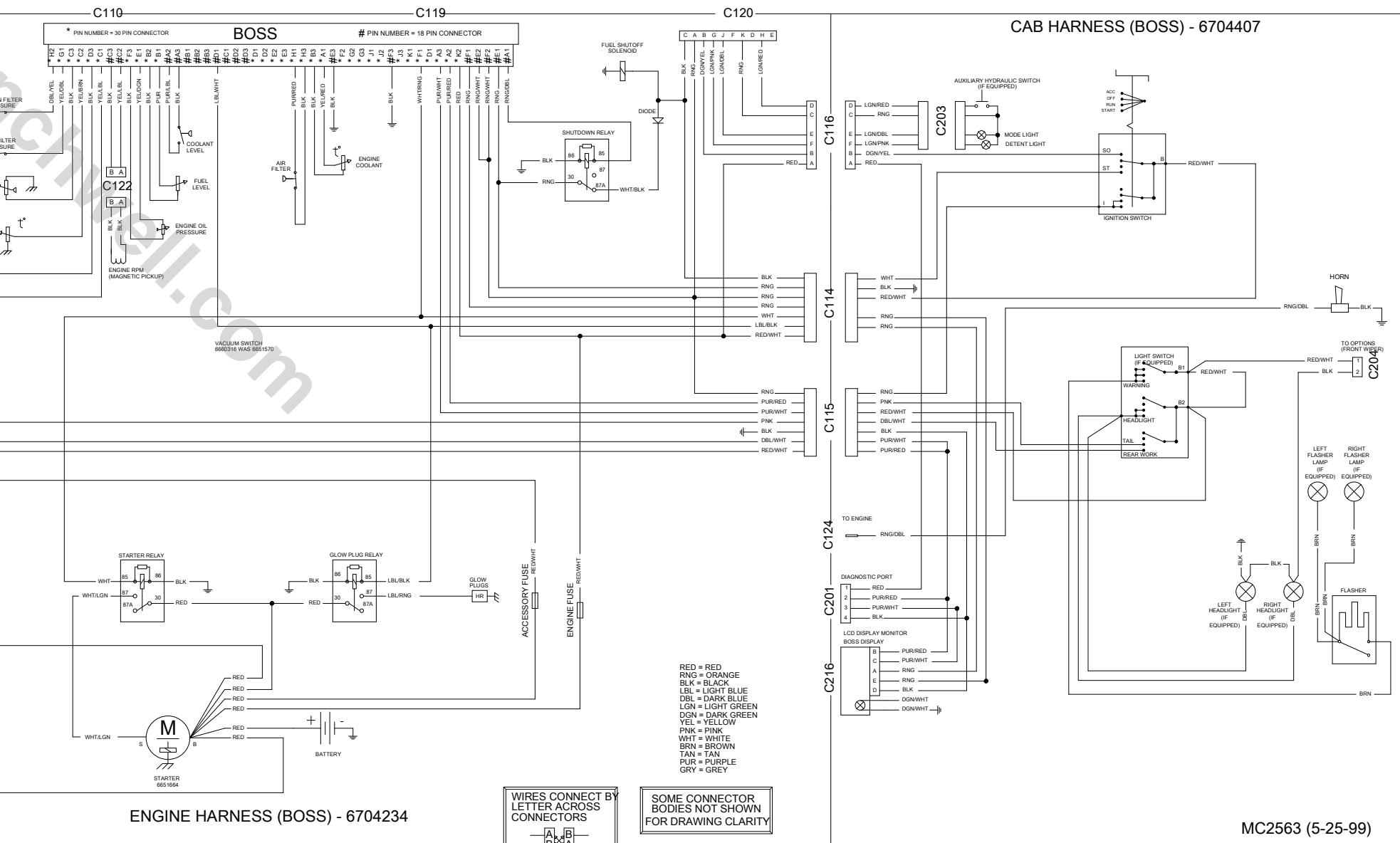

TRANSDUCER HARNESS - 6704345

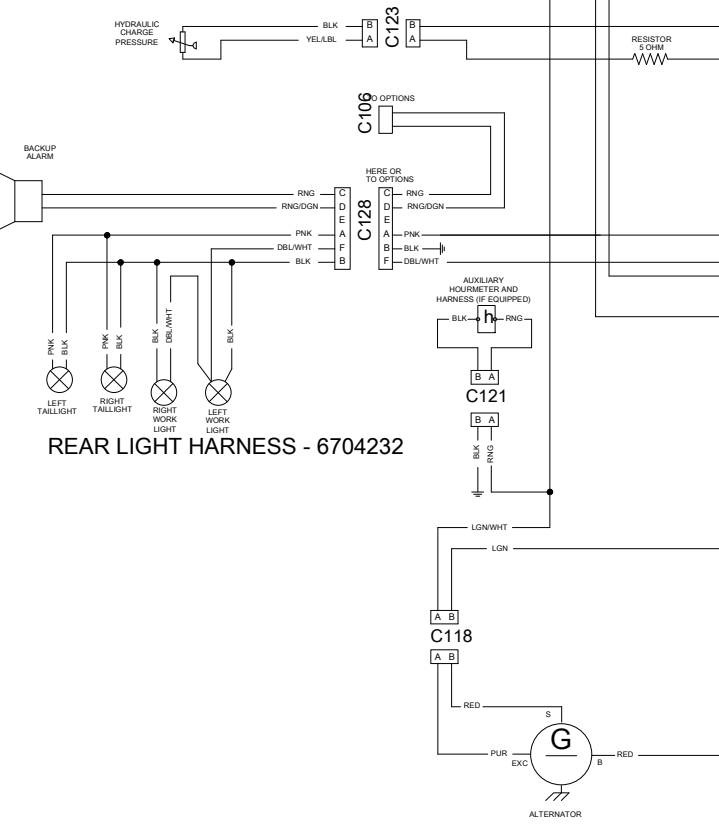

REAR LIGHT HARNESS - 6704232

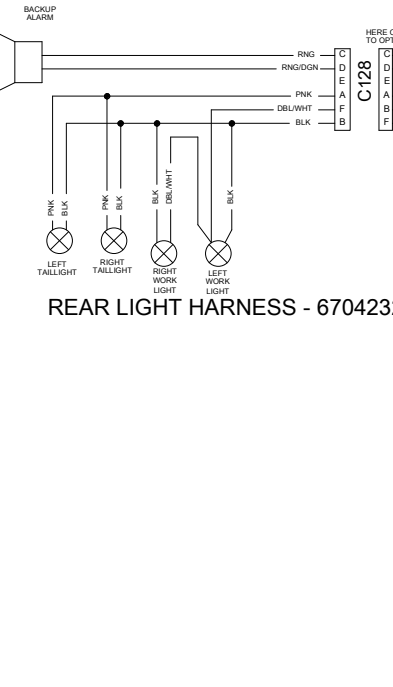

ENGINE HARNESS (BOSS) - 6704234

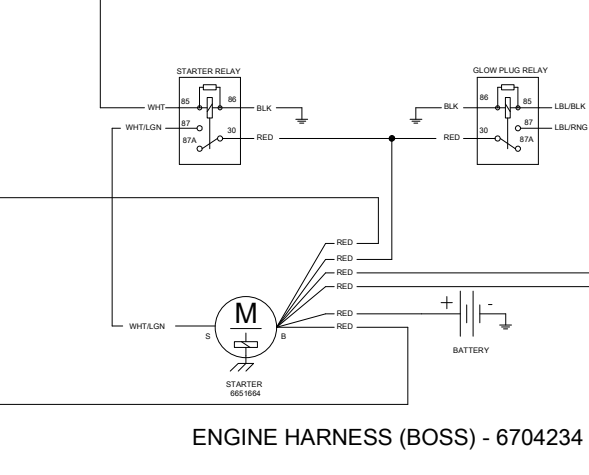

RED = RED
 RNG = ORANGE
 BLK = BLACK
 LBL = LIGHT BLUE
 DBL = DARK BLUE
 LGN = LIGHT GREEN
 DGN = DARK GREEN
 YEL = YELLOW
 PNK = PINK
 WHT = WHITE
 BRN = BROWN
 TAN = TAN
 PUR = PURPLE
 GRY = GREY

WIRES CONNECT BY LETTER ACROSS CONNECTORS

SOME CONNECTOR BODIES NOT SHOWN FOR DRAWING CLARITY

853 BOSS - WIRING SCHEMATIC

S/N 508415056-15187
S/N 509715097-15221
S/N 510250162-50448
S/N 510375093-75213
(Printed June 1999)
MC2564

CONTROLS HARNESS - 6703878

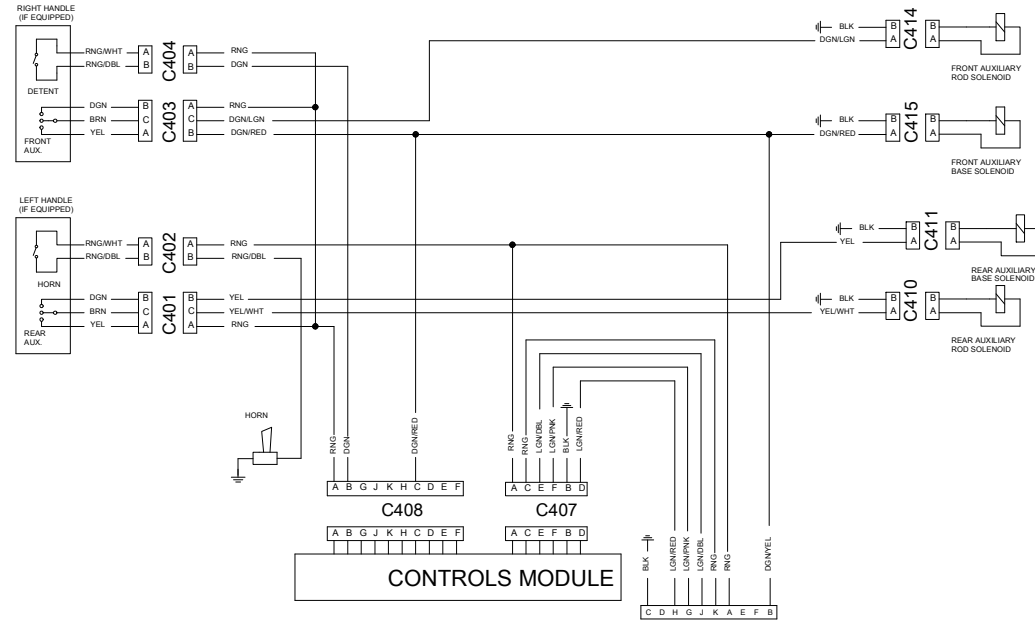

CAB HARNESS (BOSS) - 6705136

TRANSDUCER HARNESS - 6704345

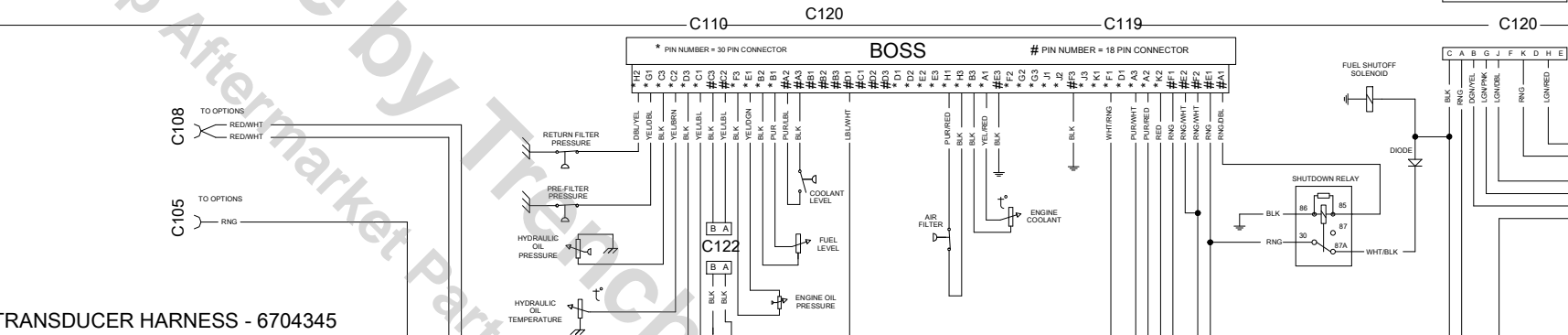

REAR LIGHT HARNESS - 6704232

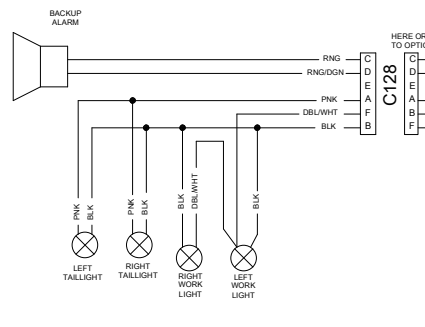

ENGINE HARNESS (BOSS) - 6705035

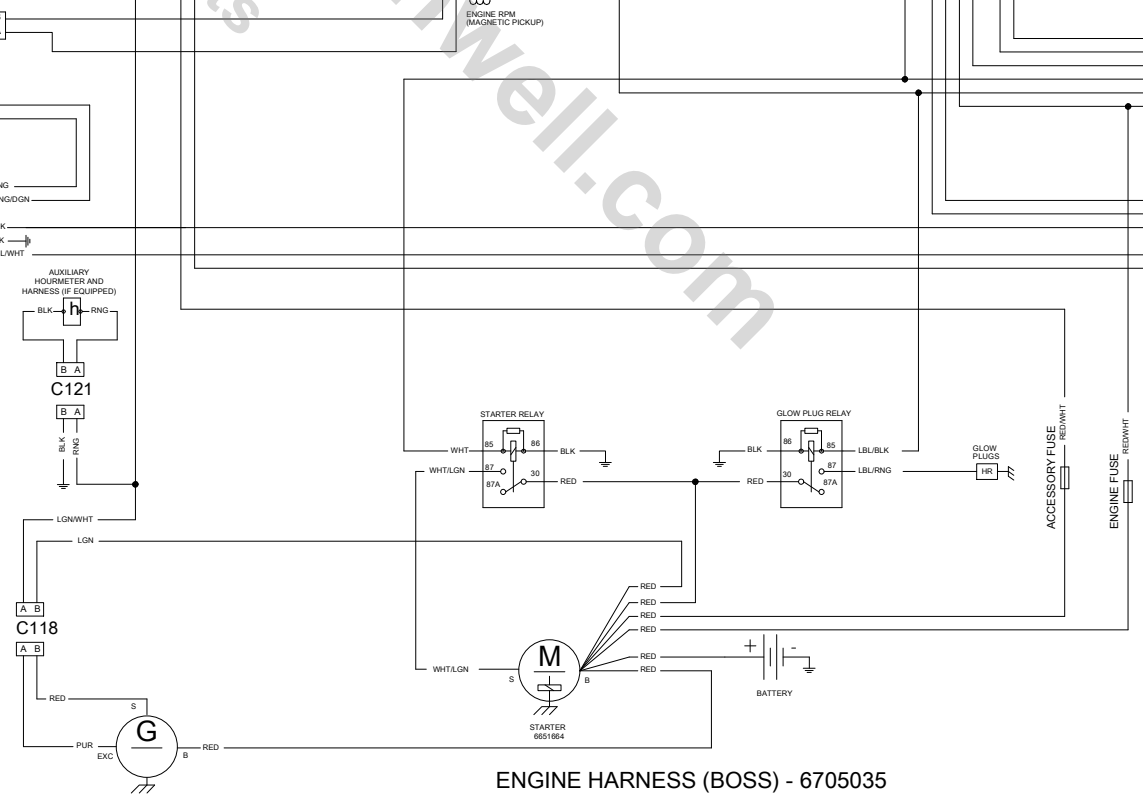

RED = RED
RNG = ORANGE
BLK = BLACK
LBL = LIGHT BLUE
DBL = DARK BLUE
LGN = LIGHT GREEN
DGN = DARK GREEN
YEL = YELLOW
PNK = PINK
WHT = WHITE
BRN = BROWN
TAN = TAN
PUR = PURPLE
GRY = GREY

WIRES CONNECT BY LETTER ACROSS CONNECTORS

SOME CONNECTOR BODIES NOT SHOWN FOR DRAWING CLARITY

853 BOSS - WIRING SCHEMATIC

S/N 508415188-15215
S/N 509715222-15292
S/N 510250449-50691
S/N 510375214-75404
(Printed June 1999)
MC2571

WITH FRONT AUXILIARY VALVE
CONTROLS HARNESS - 6705283

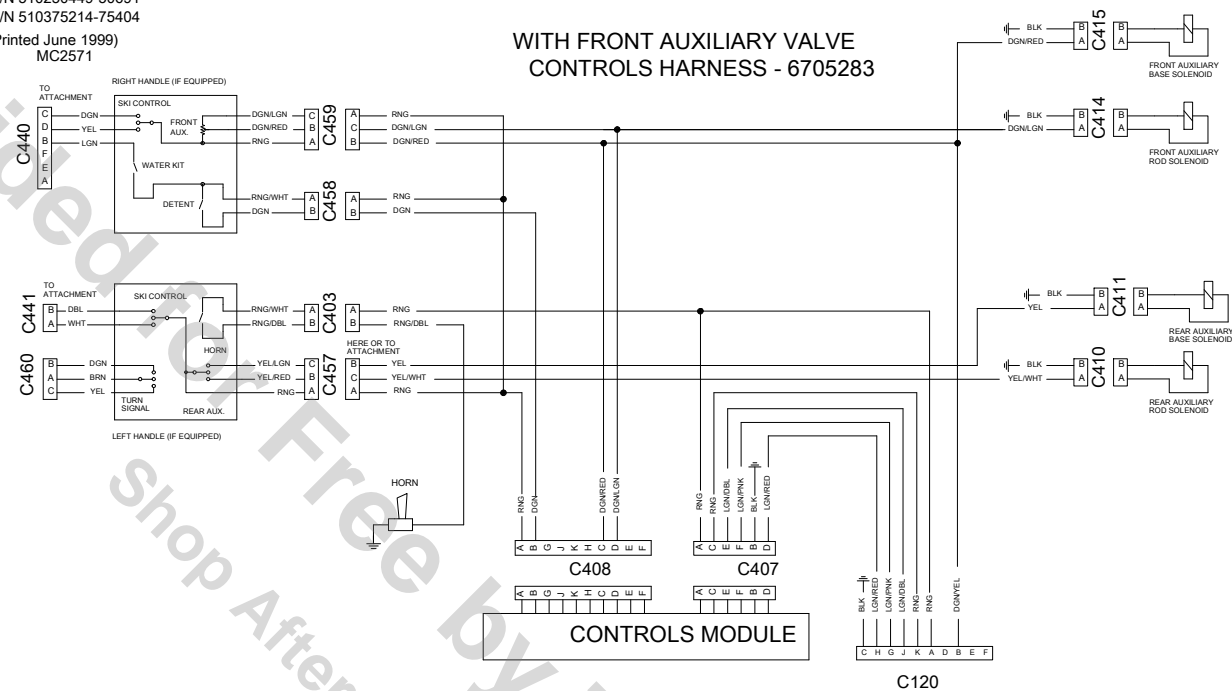

WITHOUT FRONT AUXILIARY VALVE
CONTROLS HARNESS - 6702999

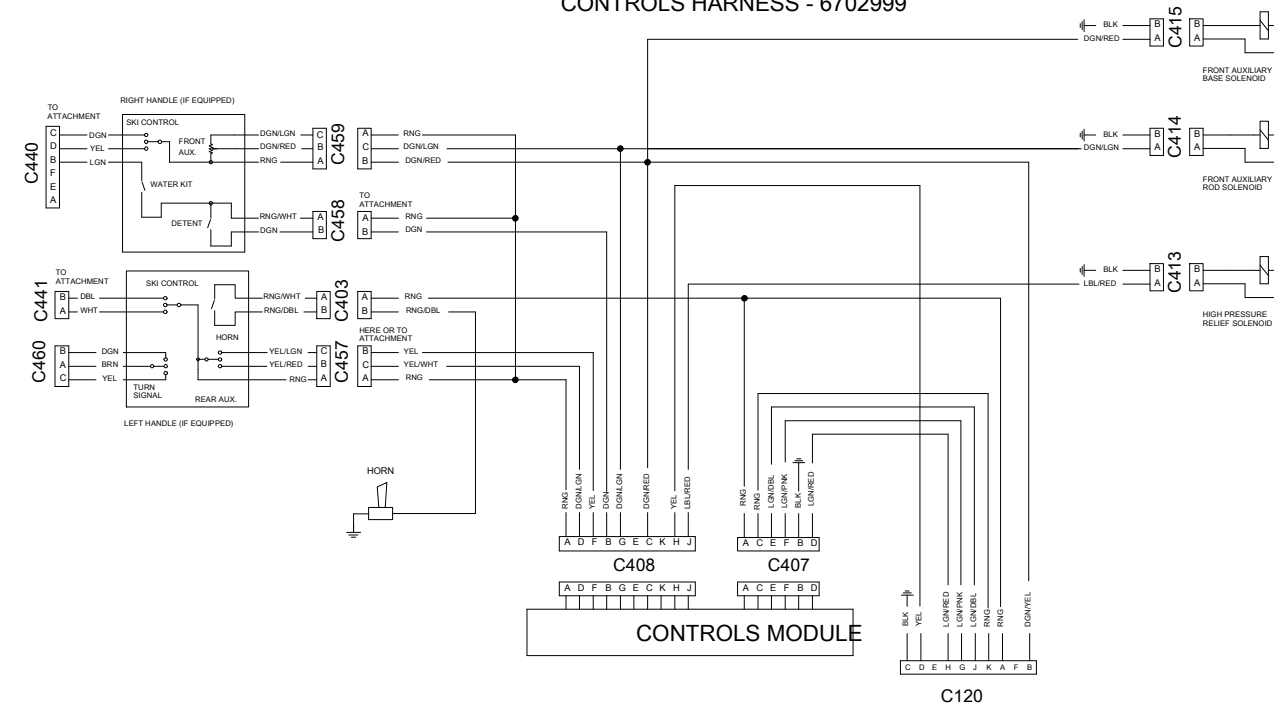

TRANSDUCER HARNESS - 6704345

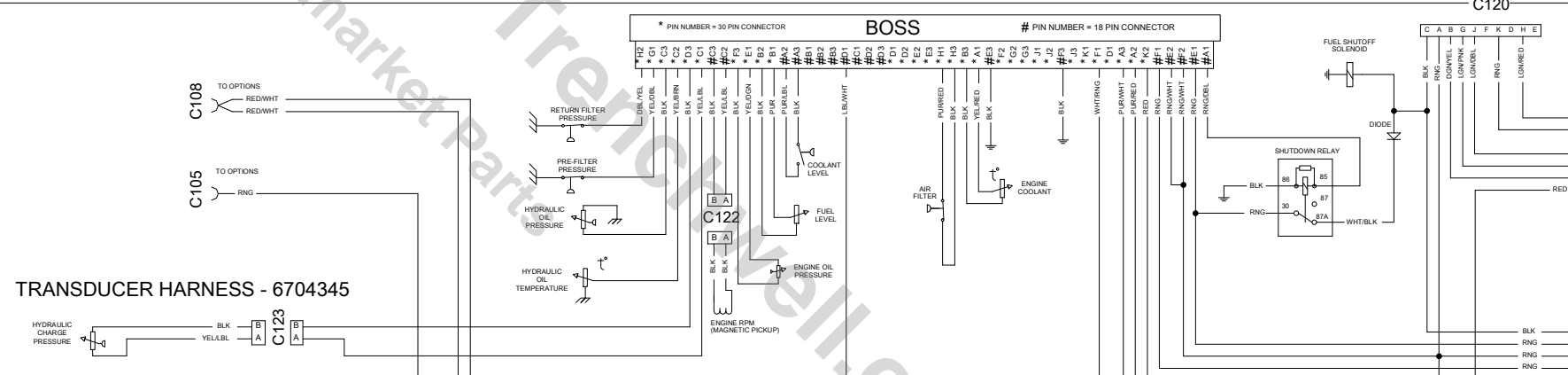

REAR LIGHT HARNESS - 6704232

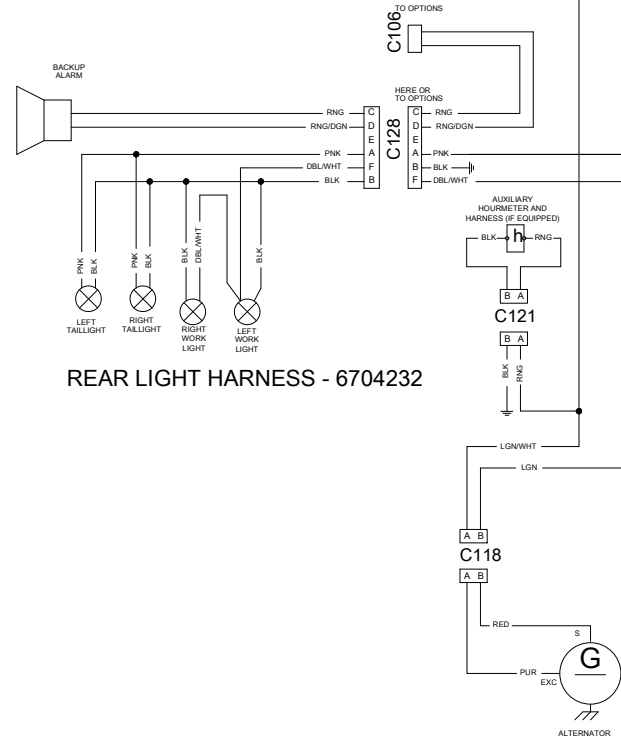

ENGINE HARNESS (BOSS) - 6705035

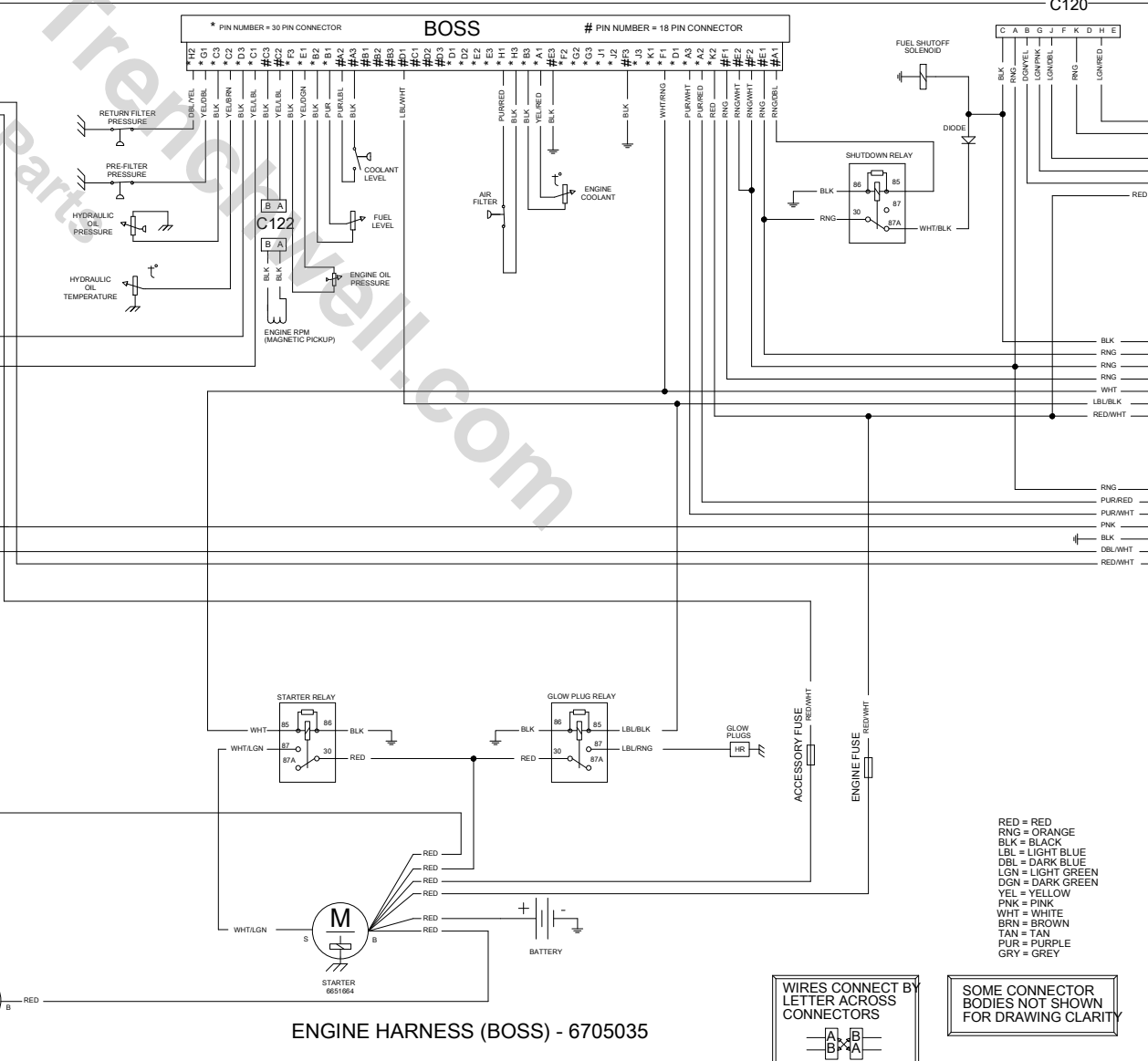

CAB HARNESS (BOSS) - 6705136

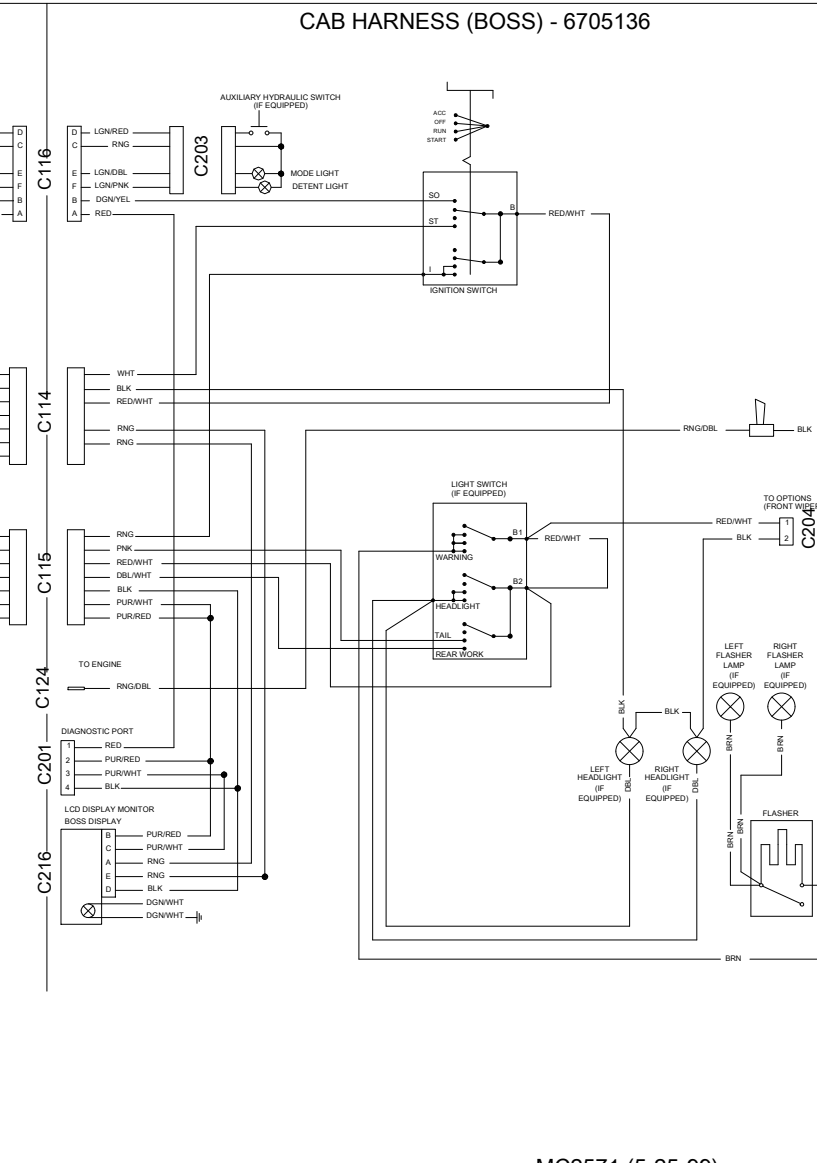

WIRES CONNECT BY LETTER ACROSS CONNECTORS

SOME CONNECTOR BODIES NOT SHOWN FOR DRAWING CLARITY

853 BOSS - WIRING SCHEMATIC

S/N 508415216-17999
S/N 509715293-17999
S/N 510250692 AND ABOVE
S/N 510375405 AND ABOVE
S/N 512815001-15999
(Printed June 1999)
MC2573

WITH FRONT AUXILIARY VALVE
CONTROLS HARNESS - 6705283

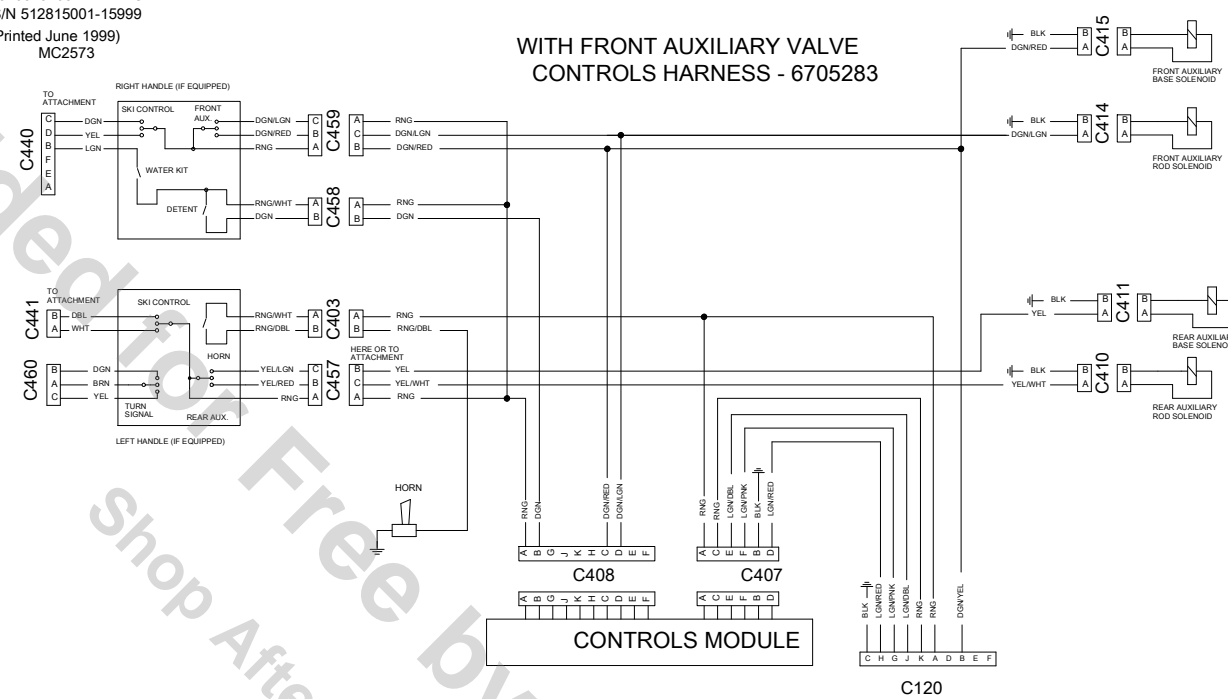

WITHOUT FRONT AUXILIARY VALVE
CONTROLS HARNESS - 6702999

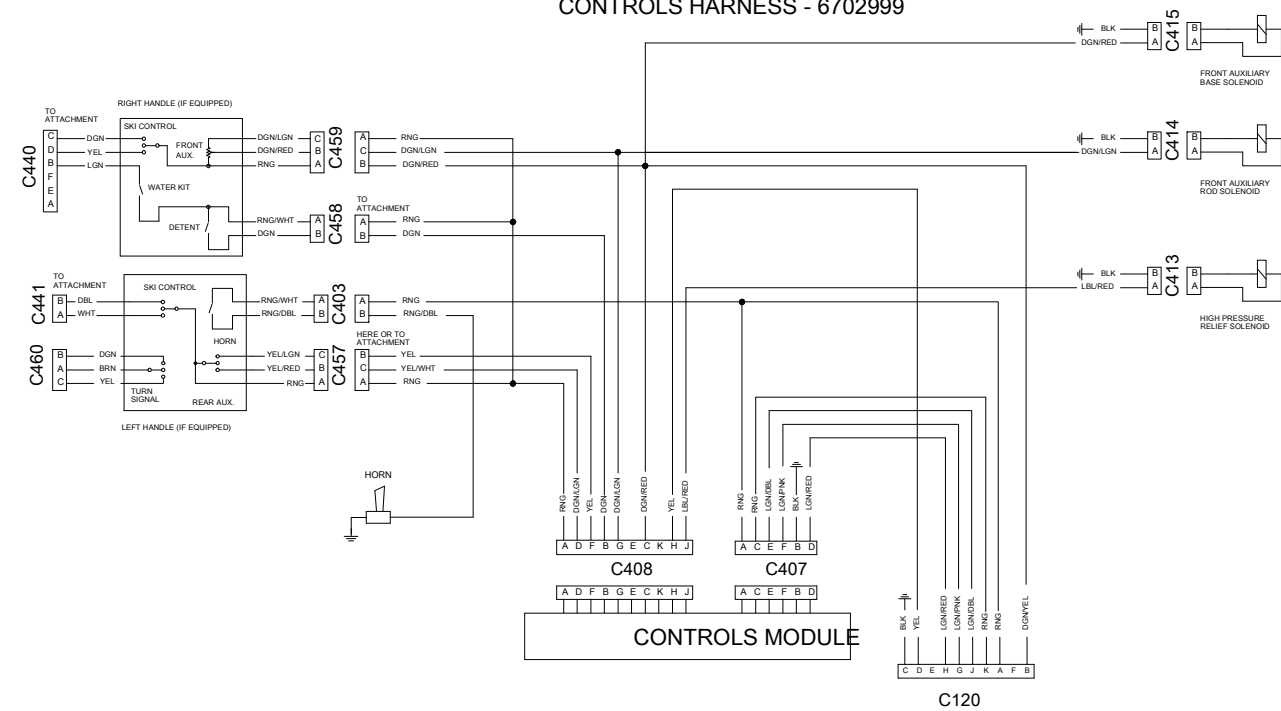

C110 BOSS C119

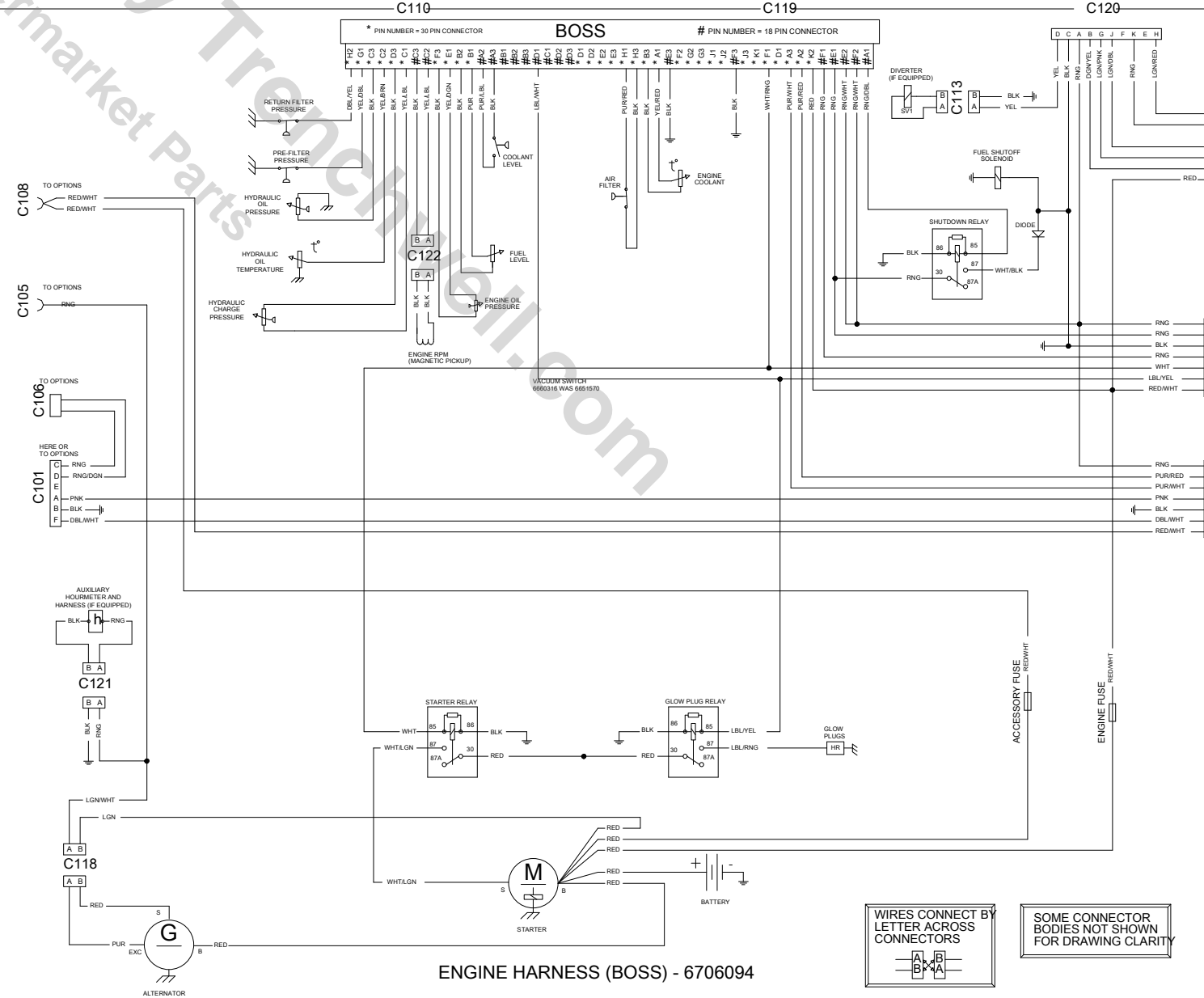

CAB HARNESS (BOSS) - 6705136

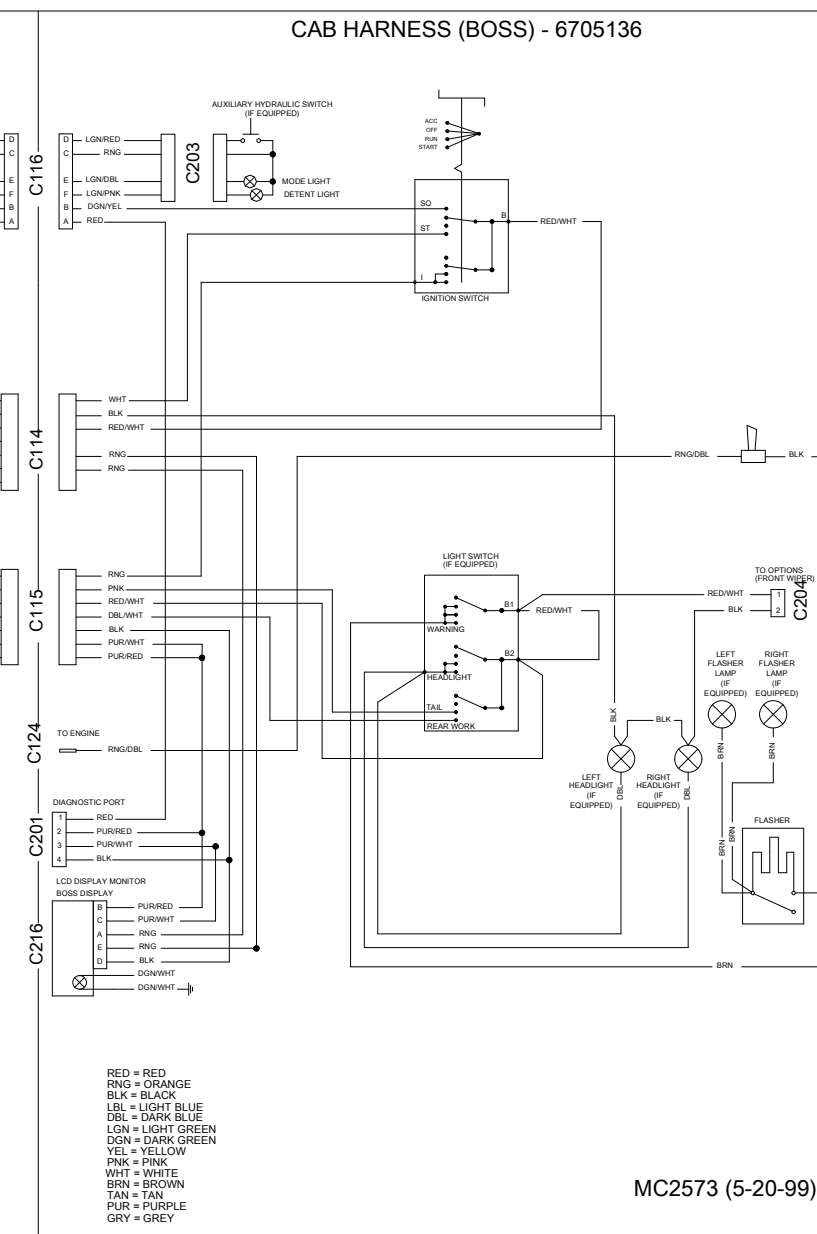

RED = RED
RNG = ORANGE
BLK = BLACK
LBL = LIGHT BLUE
DBL = DARK BLUE
LGN = LIGHT GREEN
YEL = YELLOW
PNK = PINK
WHT = WHITE
BRN = BROWN
TAN = TAN
PUR = PURPLE
GRY = GREY

WIRES CONNECT BY
LETTER ACROSS
CONNECTORS

SOME CONNECTOR
BODIES NOT SHOWN
FOR DRAWING CLARITY

ENGINE HARNESS (BOSS) - 6706094

CONTROLS HARNESS - 6703878

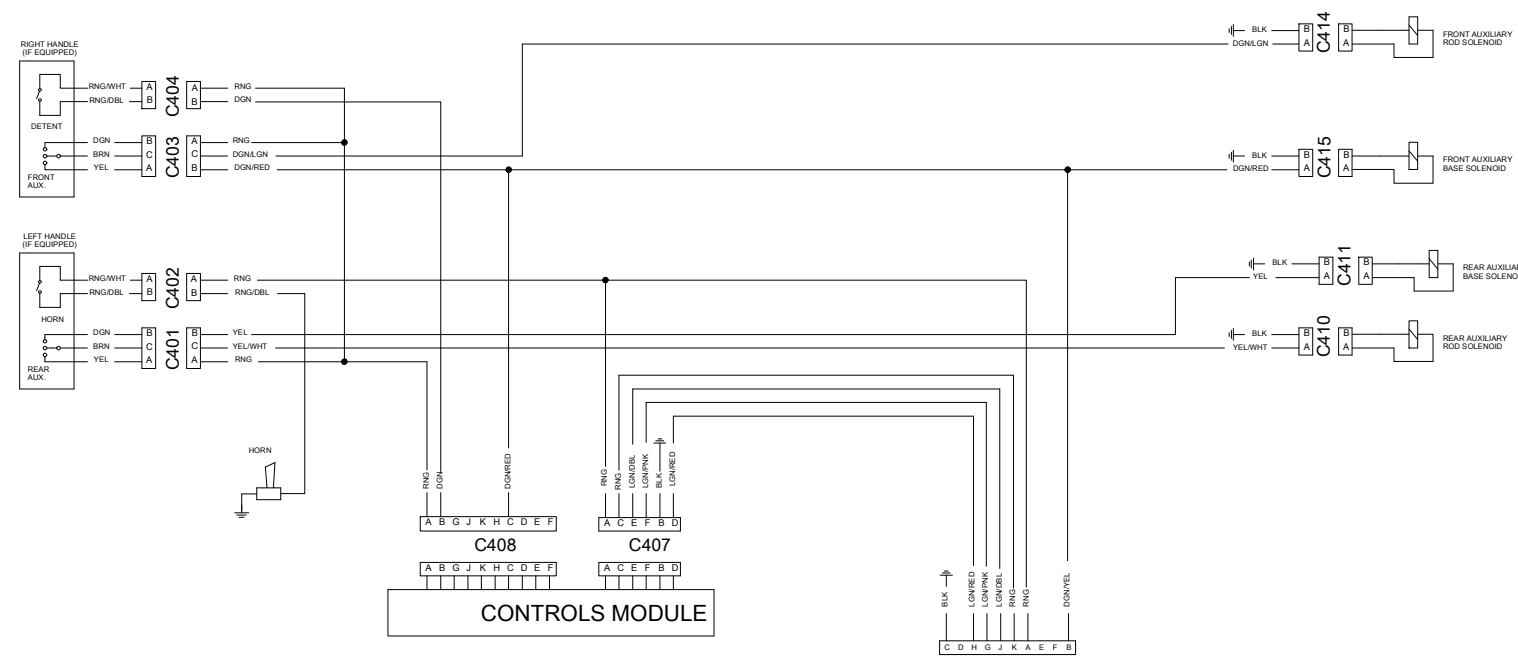

CAB HARNESS (WITHOUT BOSS) - 6704494

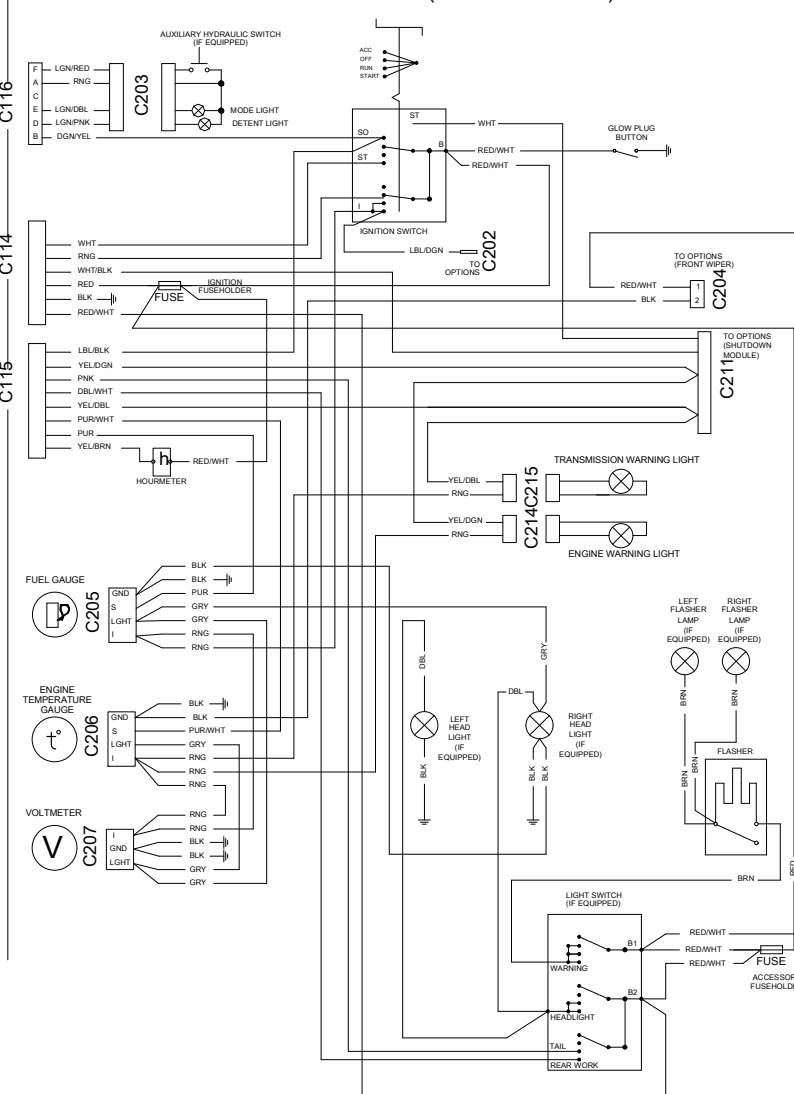

ENGINE HARNESS (WITHOUT BOSS) - 6704587

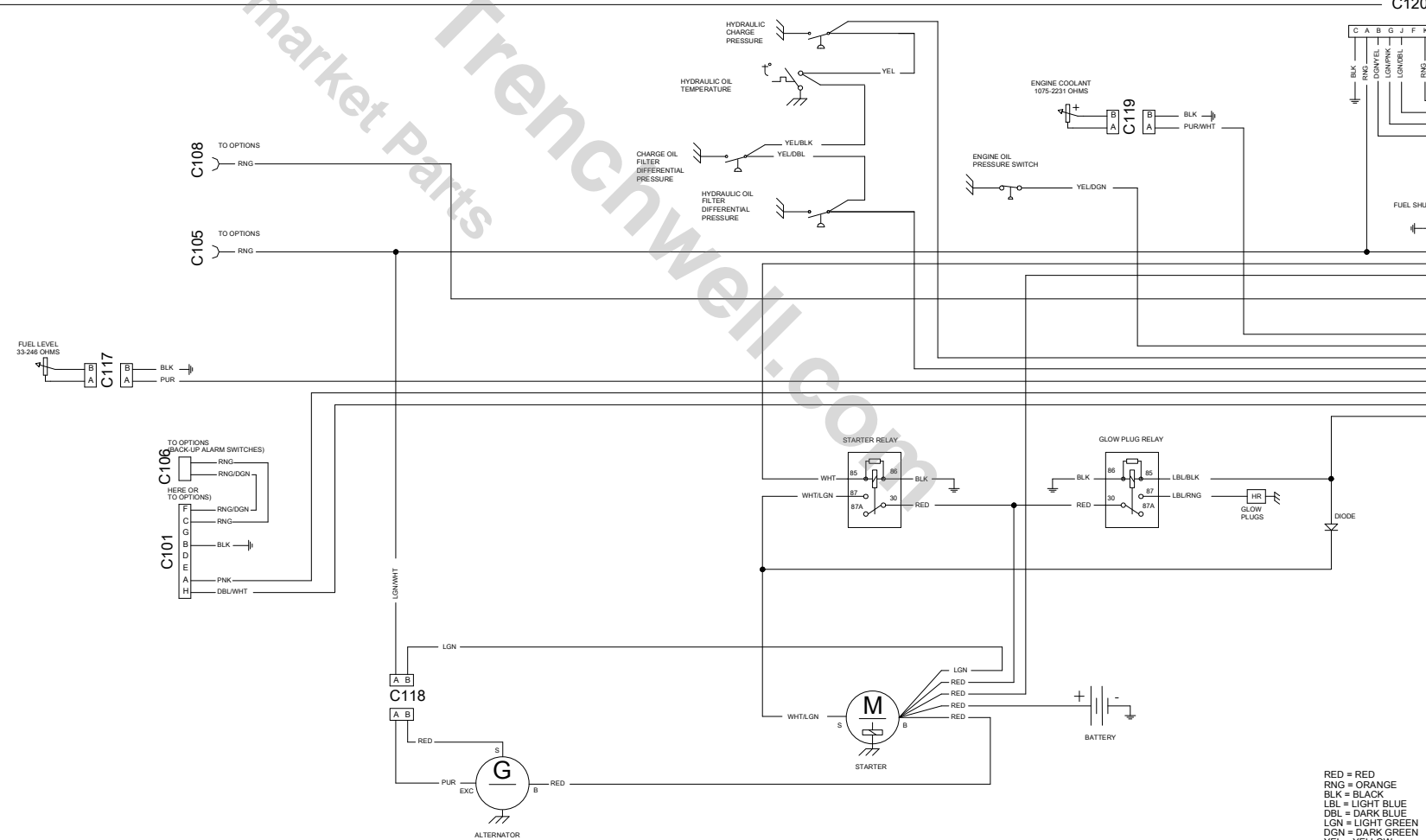

RED = RED
 RNG = ORANGE
 BLK = BLACK
 LBL = LIGHT BLUE
 DBL = DARK BLUE
 LGN = LIGHT GREEN
 DGN = DARK GREEN
 YEL = YELLOW
 PNK = PINK
 WHT = WHITE
 BRN = BROWN
 TAN = TAN
 PUR = PURPLE
 GRY = GREY

WIRES CONNECT BY
 LETTER ACROSS
 CONNECTORS

SOME CONNECTOR
 BODIES NOT SHOWN
 FOR DRAWING CLARITY

853 WITHOUT BOSS - WIRING SCHEMATIC

S/N 510125240-26110
(Printed June 1999)
MC2569

CONTROLS HARNESS - 6703878

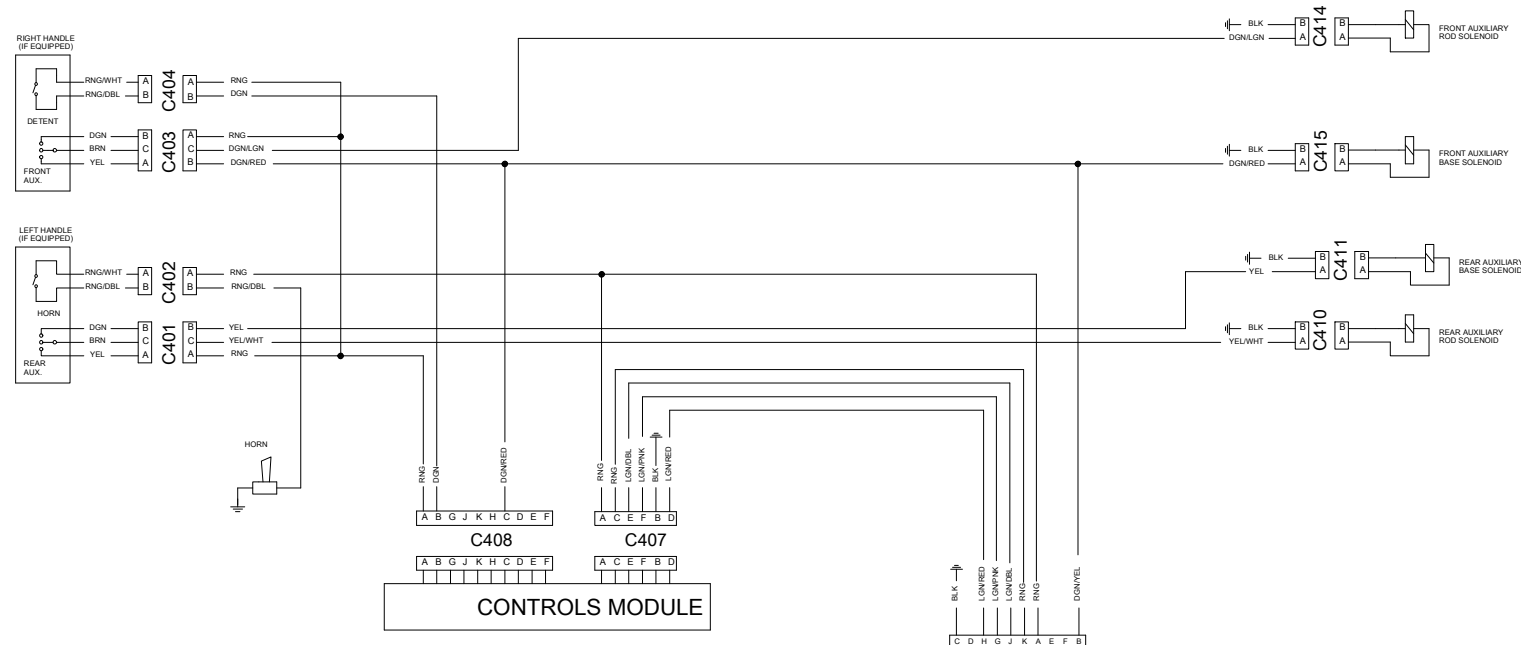

CHARGE PRESSURE HARNESS - 6704931

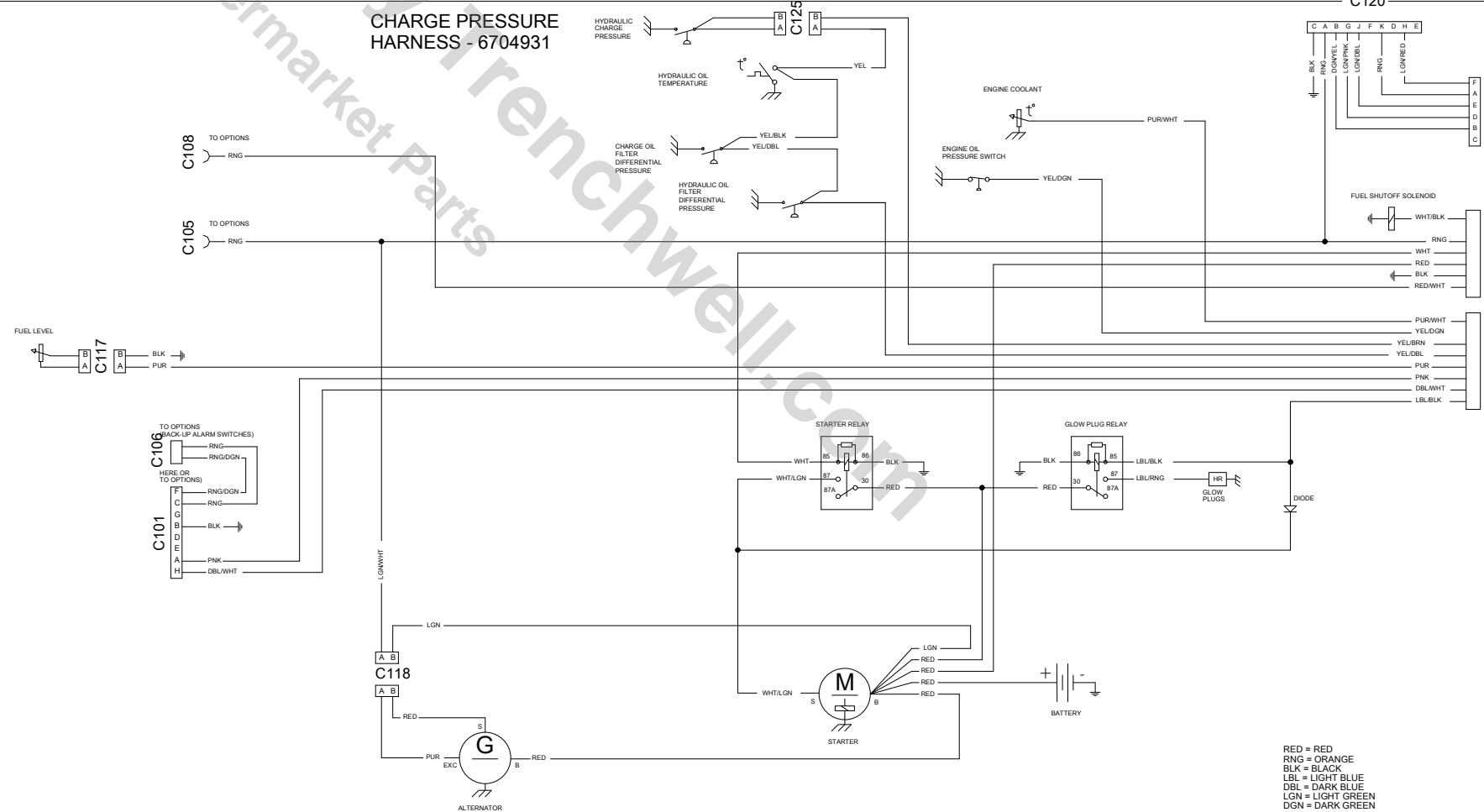

ENGINE HARNESS (WITHOUT BOSS) - 6704932 OR 6705111

CAB HARNESS (WITHOUT BOSS) - 6704494

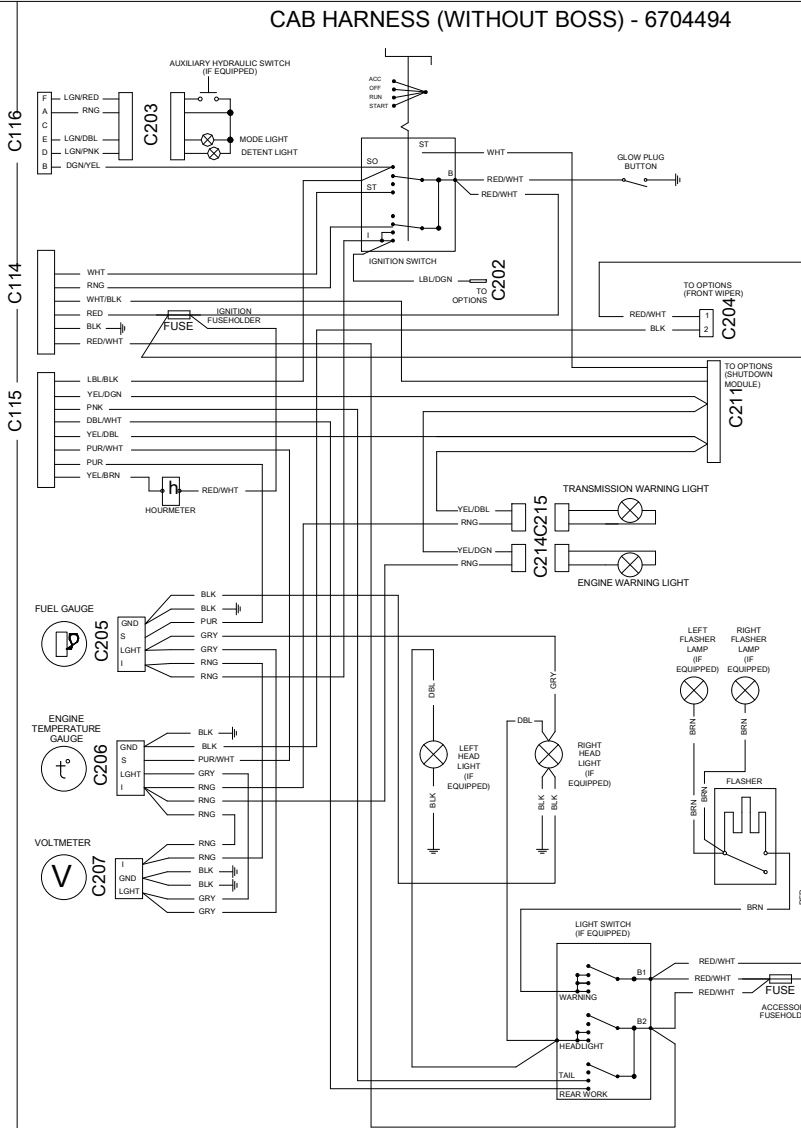

RED = RED
RNG = ORANGE
BLK = BLACK
LBL = LIGHT BLUE
DBL = DARK BLUE
LGN = LIGHT GREEN
DGN = DARK GREEN
YEL = YELLOW
PNK = PINK
WHT = WHITE
BRN = BROWN
TAN = TAN
PUR = PURPLE
GRY = GREY

WIRES CONNECT BY LETTER ACROSS CONNECTORS

SOME CONNECTOR BODIES NOT SHOWN FOR DRAWING CLARITY

853 WITHOUT BOSS - WIRING SCHEMATIC

S/N 510126111 AND ABOVE
S/N 512811001-14999
(Printed June 1999)
MC2570

WITH FRONT AUXILIARY VALVE
CONTROLS HARNESS - 6705283

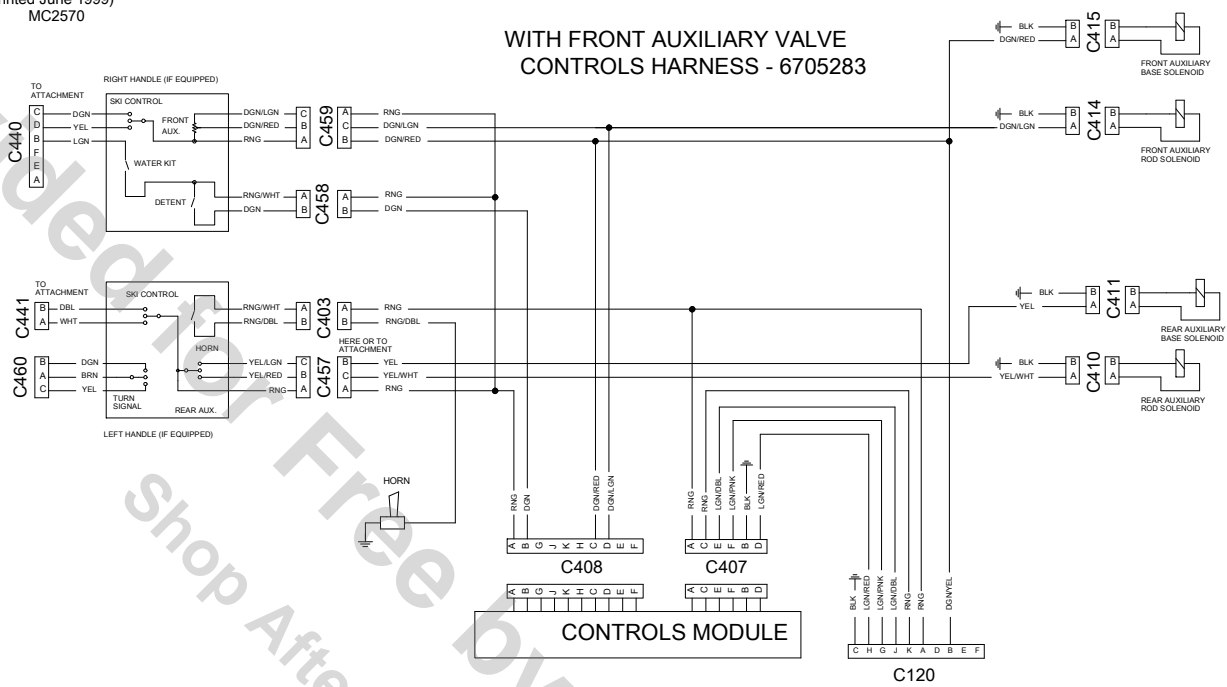

WITHOUT FRONT AUXILIARY VALVE
CONTROLS HARNESS - 6702999

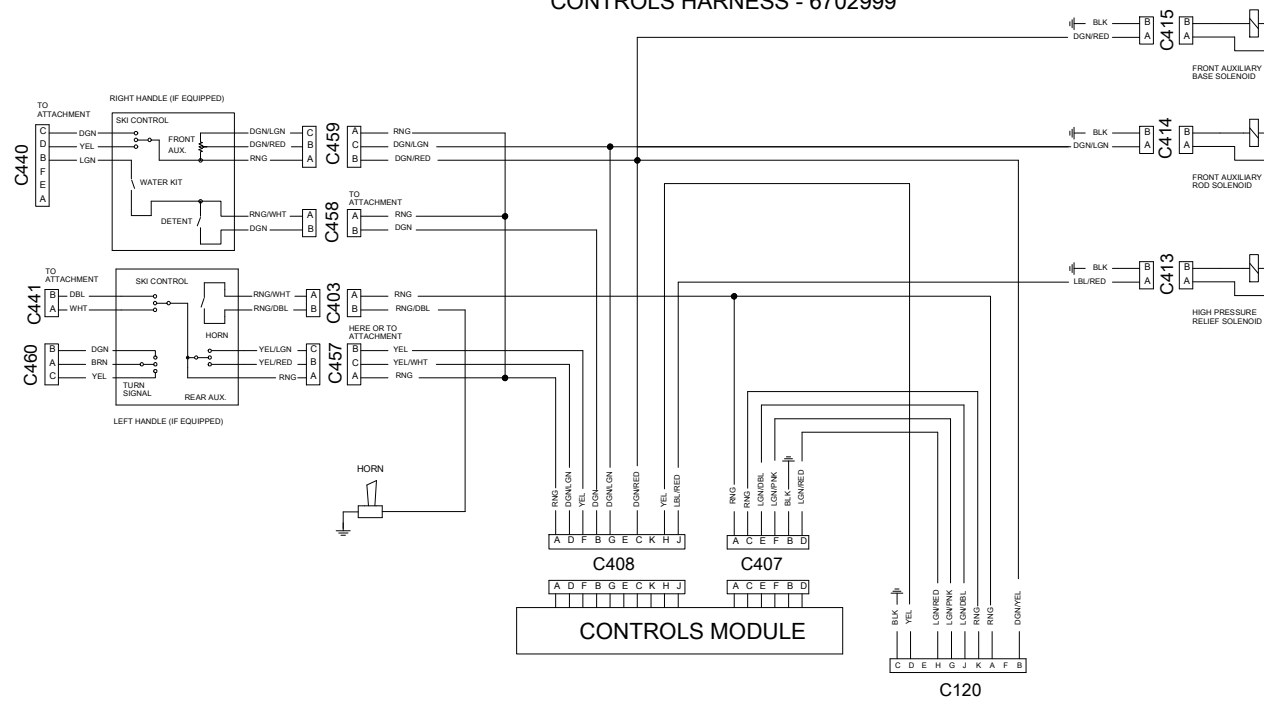

CHARGE PRESSURE
HARNESS - 6704931

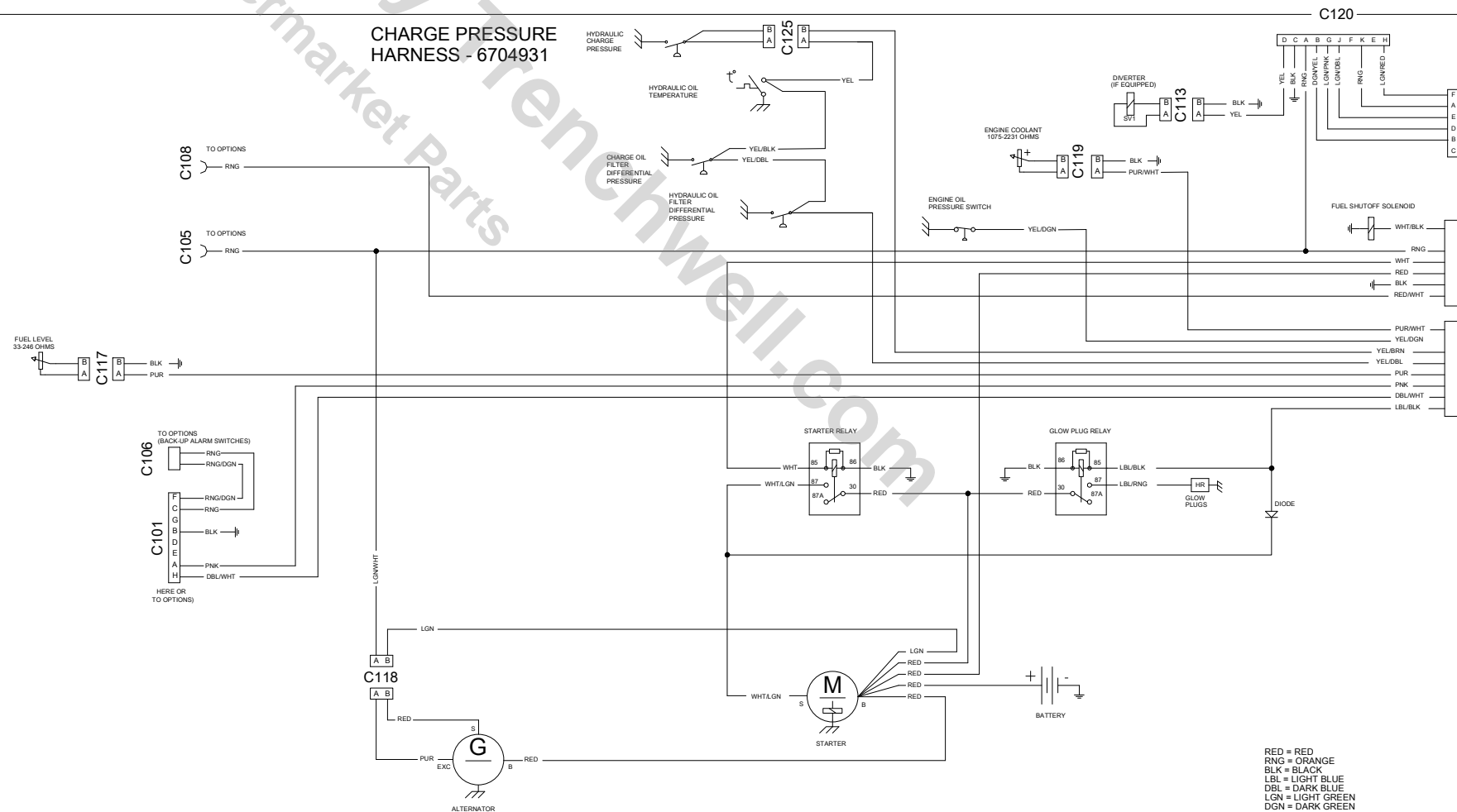

ENGINE HARNESS (WITHOUT BOSS) - 6706222

CAB HARNESS (WITHOUT BOSS) - 6704494

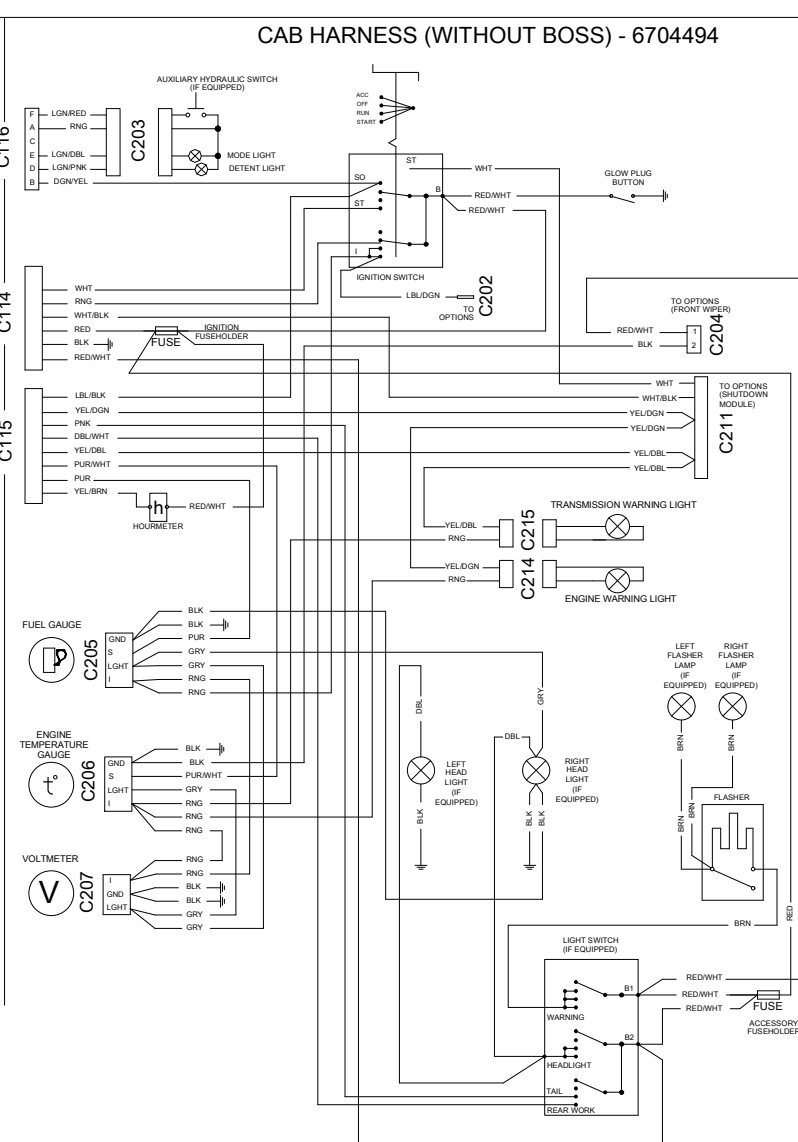

RED = RED
RNG = ORANGE
BLK = BLACK
LBL = LIGHT BLUE
DBL = DARK BLUE
LGN = LIGHT GREEN
DGN = DARK GREEN
YEL = YELLOW
PNK = PINK
WHT = WHITE
BRN = BROWN
TAN = TAN
PUR = PURPLE
GRY = GREY

WIRES CONNECT BY
LETTER ACROSS
CONNECTORS

SOME CONNECTOR
BODIES NOT SHOWN
FOR DRAWING CLARITY

853 - WIRING SCHEMATIC

ATTACHMENT CONTROL OPTION

S/N 508415001-17999

S/N 509715001-17999

S/N 510125001 AND ABOVE

S/N 510250001 AND ABOVE

S/N 510375001 AND ABOVE

S/N 512811001-15999

(Printed June 1999)

MC2574

ATTACHMENT CONTROLS HARNESS - 6705901

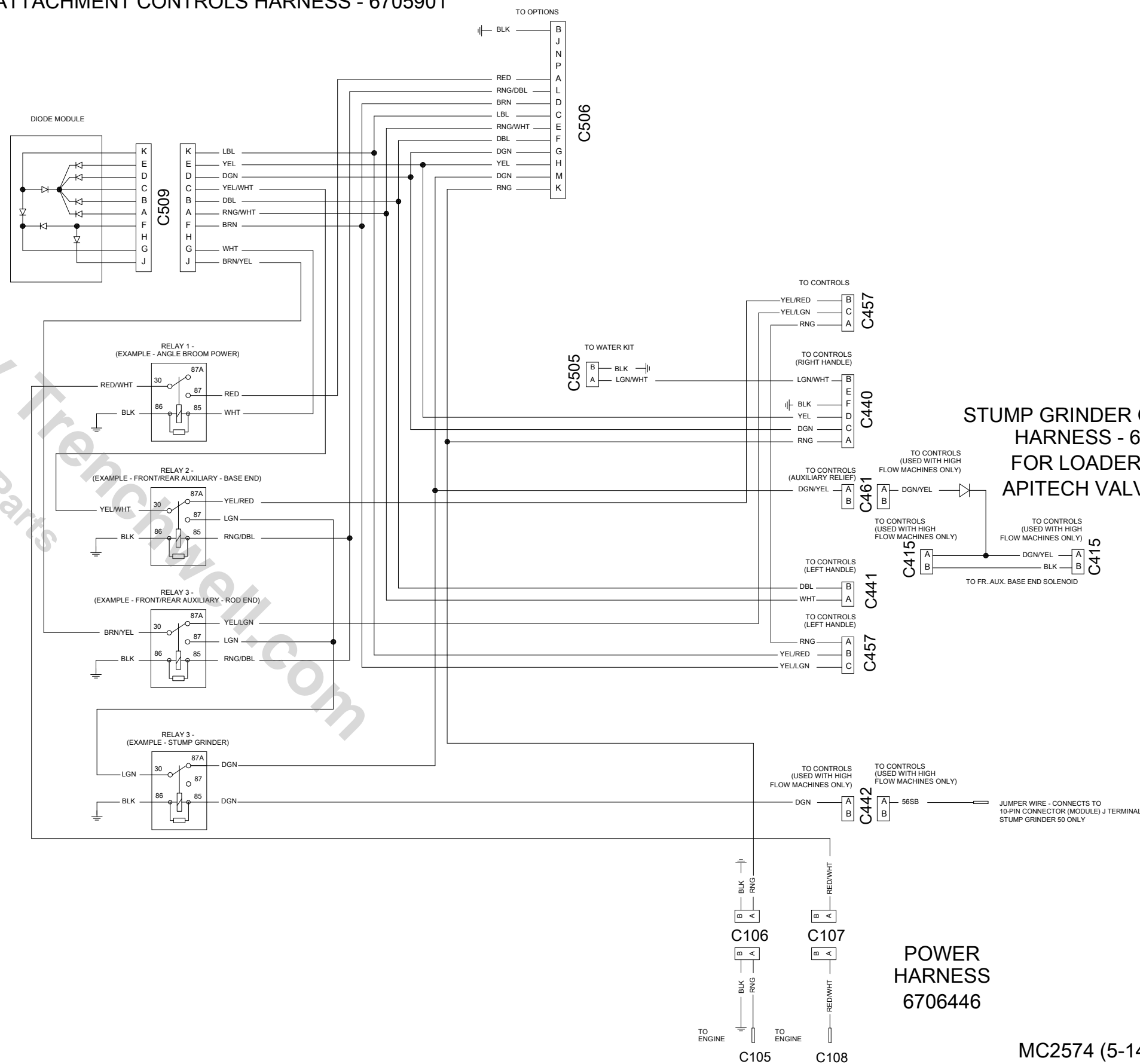

RED = RED
 RNG = ORANGE
 BLK = BLACK
 LBL = LIGHT BLUE
 LGN = LIGHT GREEN
 DGN = DARK GREEN
 YEL = YELLOW
 PNK = PINK
 WHT = WHITE
 BRN = BROWN
 TAN = TAN
 PUR = PURPLE
 GRY = GREY

WIRES CONNECT BY LETTER ACROSS CONNECTORS

SOME CONNECTOR BODIES NOT SHOWN FOR DRAWING CLARITY

STUMP GRINDER OR GRADER HARNESS - 6706552 FOR LOADERS WITH APITECH VALVE ONLY

POWER HARNESS 6706446

MC2574 (5-14-99)

Provided for Free by Trencher.com Shop Aftermarket Parts

853 BOSS - WIRING SCHEMATIC

S/N 512811001 - 14999

(Printed January 2005)
V-0803

WITH FRONT AUXILIARY VALVE
CONTROLS HARNESS - 6705283

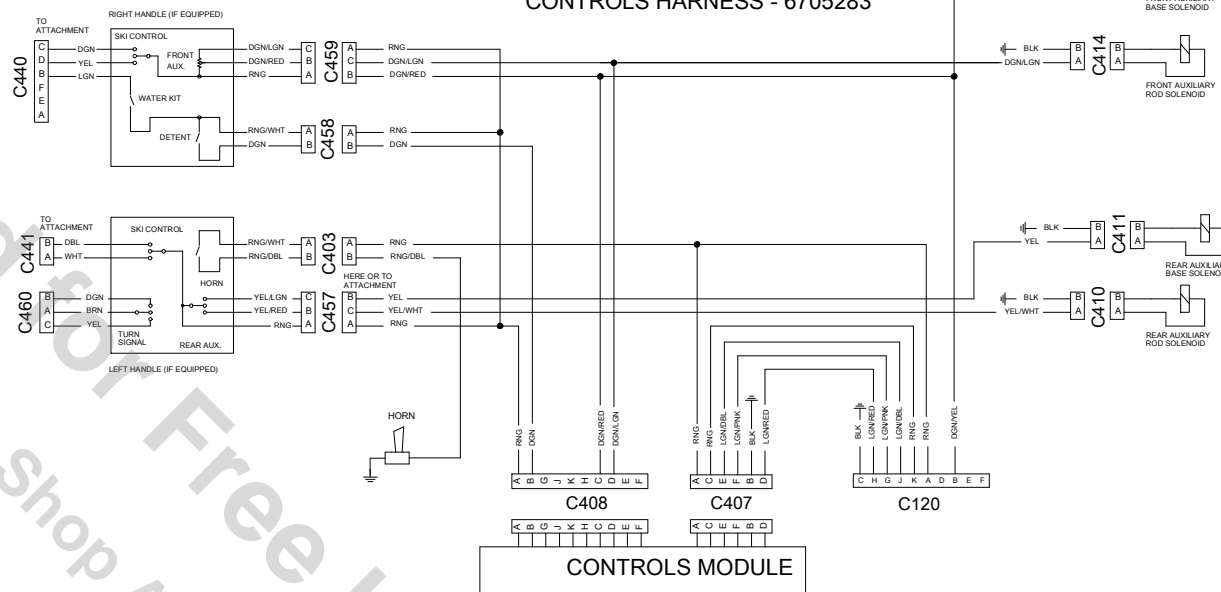

WITHOUT FRONT AUXILIARY VALVE
CONTROLS HARNESS - 6702999

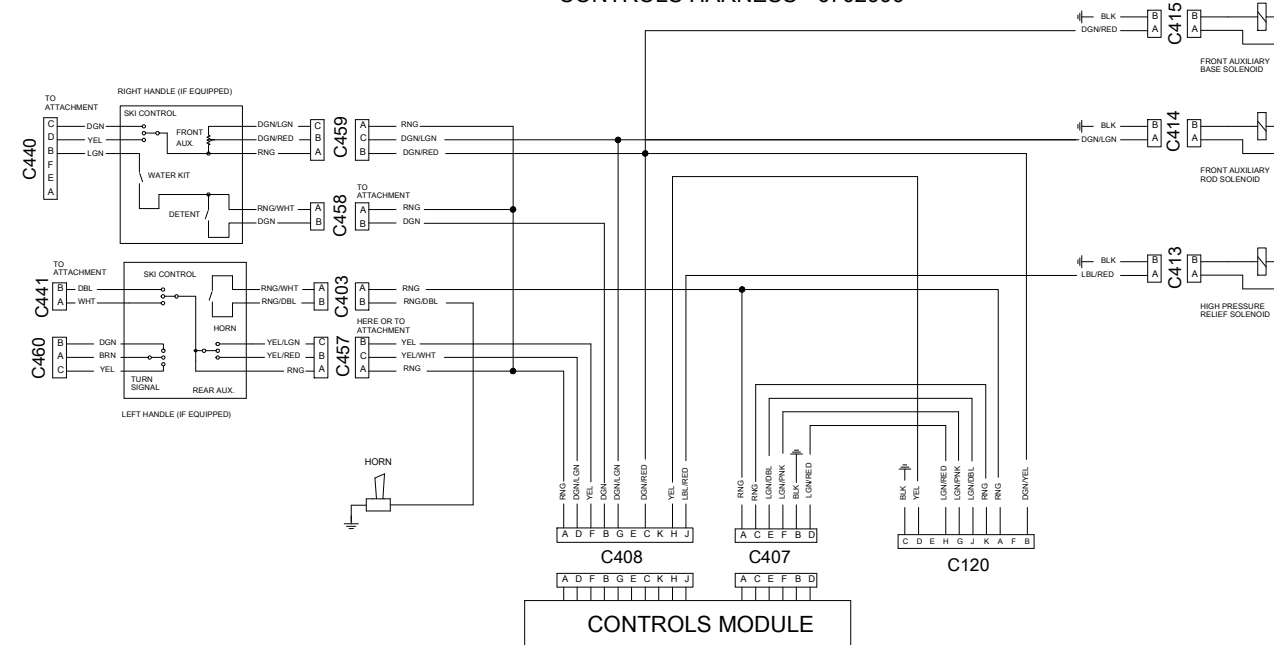

TRANSDUCER HARNESS - 6704345

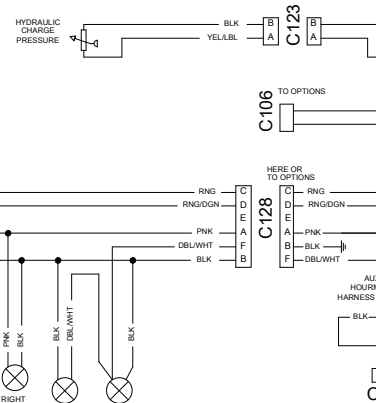

REAR LIGHT HARNESS - 6704232



ENGINE HARNESS (BOSS) - 6704234

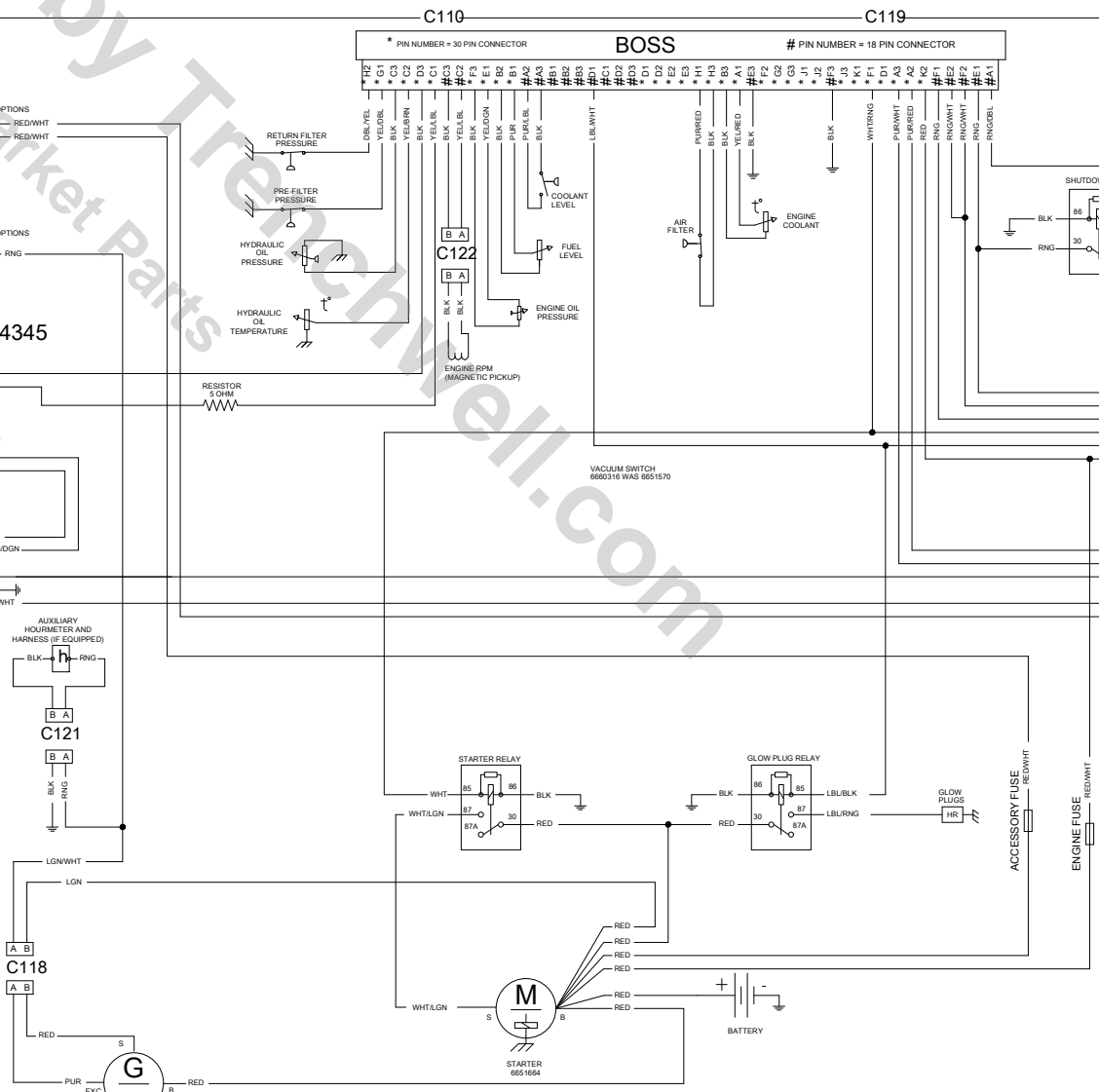

CAB HARNESS (BOSS) - 6705136

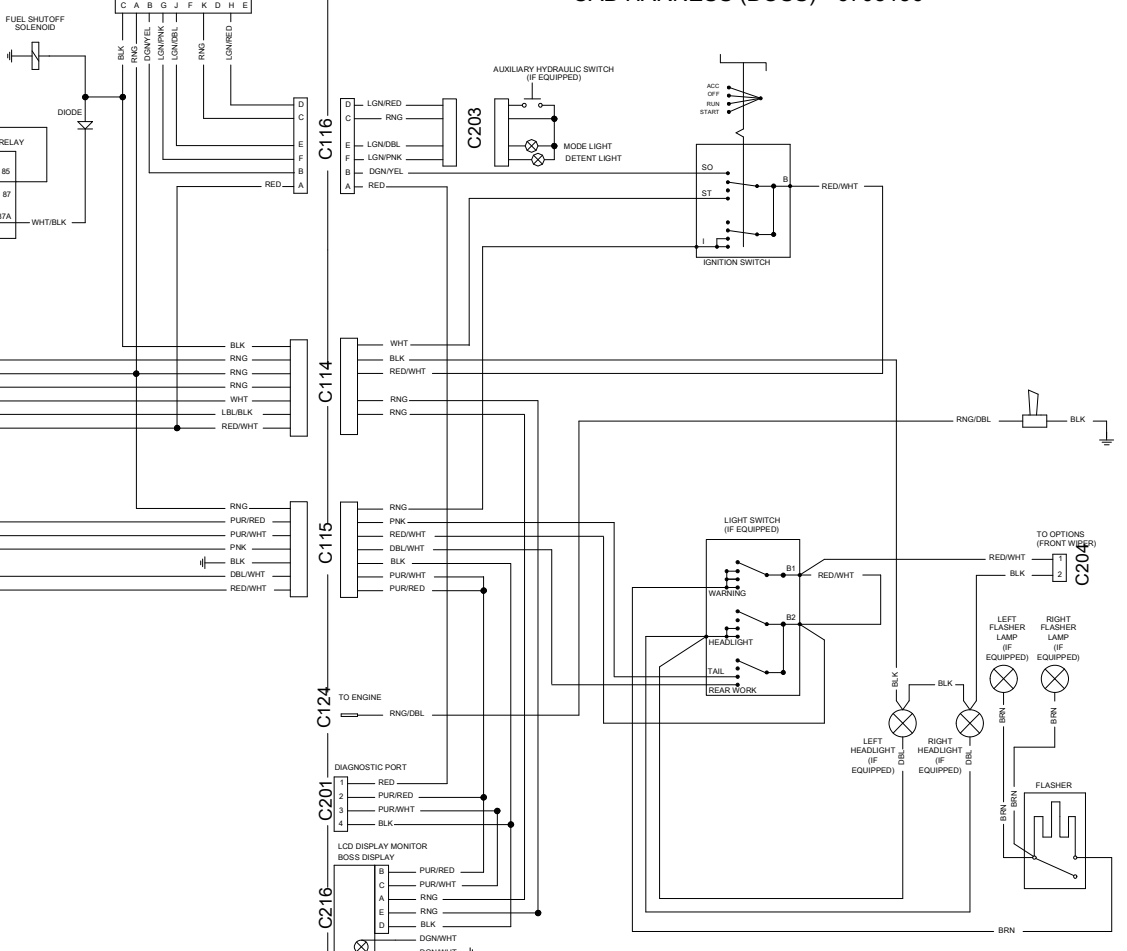

RED = RED
RNG = ORANGE
BLK = BLACK
LBL = LIGHT BLUE
DBL = DARK BLUE
LGN = LIGHT GREEN
DGN = DARK GREEN
YEL = YELLOW
PNK = PINK
WHT = WHITE
BRN = BROWN
TAN = TAN
PUR = PURPLE
GRY = GREY

WIRES CONNECT BY
LETTER ACROSS
CONNECTORS

SOME CONNECTOR
BODIES NOT SHOWN
FOR DRAWING CLARITY

TROUBLESHOOTING**Chart**

The following troubleshooting chart is provided for assistance in locating and correcting problems. Many of the recommended procedures must be done by authorized Bobcat Service Personnel only.

**WARNING**

Instructions are necessary before operating or servicing machine. Read and understand the Operation & Maintenance Manuals, Handbook and signs (decals) on machine. Follow warnings and instructions in the manuals when making repairs, adjustments or servicing. Check for correct function after adjustments, repairs or service. Untrained operators and failure to follow instructions can cause injury or death.

W-2003-0199

PROBLEM	CAUSE
Battery will not take a charge.	2, 3, 4
Alternator will not charge.	1, 4
Starter will not turn the engine.	2, 3, 4, 6, 7, 8, 9

KEY TO CORRECT THE CAUSE

1. Alternator belt is loose or damaged.
2. Battery connections are dirty or loose.
3. Battery is damaged.
4. The cable & wire connection are not making a good contact.
5. The alternator is damaged.
6. The engine is locked.
7. The starter is damaged.
8. The wiring or the solenoid is damaged.
9. Check the fuses.

ELECTRICAL SYSTEM INFORMATION

Description

The loader has a 12 volt, negative ground alternator charging system. The electrical system is protected by fuses. The fuses will protect the electrical system when there is an electrical overload. The reason for the overload must be found before starting the engine again.

Fuse Location

The electrical system for the (S/N 5102), (S/N 5103) and earlier model 853 loaders are protected by two fuses (Item 1) **[A]** installed in the wiring harness located in the engine compartment.

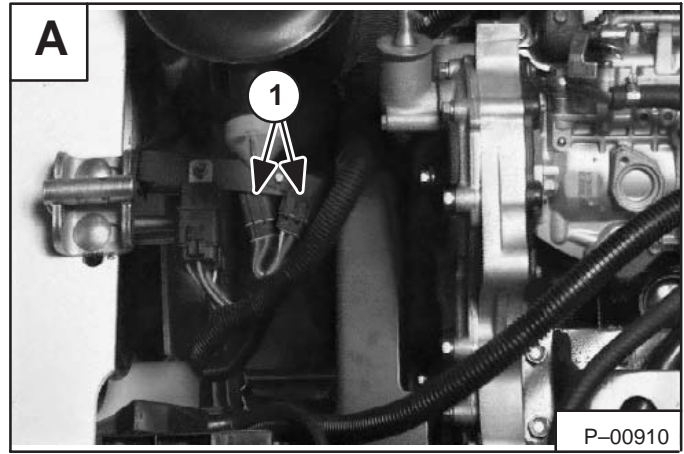

The electrical system for the (S/N 5101) and (S/N 11010 & Below) loaders are protected by two fuses (Item 1) **[B]** installed in the instrument panel.

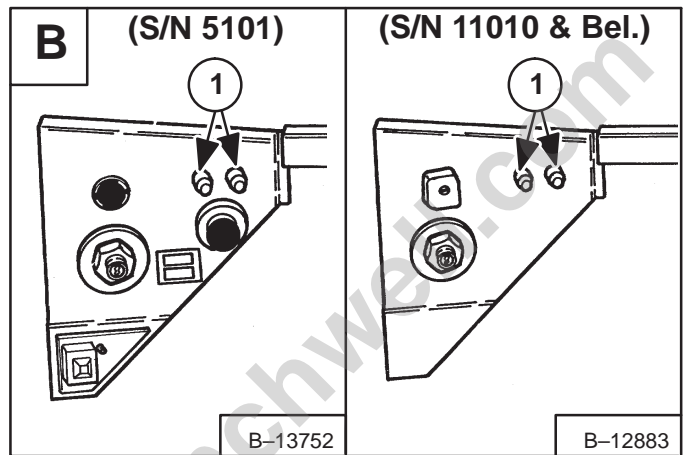

Provided for Free by Trenchworks.com
Shop Aftermarket Parts

BATTERY**Removal And Installation**

WARNING

Batteries contain acid which burns eyes and skin on contact. Wear goggles, protective clothing and rubber gloves to keep acid off body.

In case of acid contact, wash immediately with water. In case of eye contact get prompt medical attention and wash eye with clean, cool water for at least 15 minutes.

If electrolyte is taken internally drink large quantities of water or milk! DO NOT induce vomiting. Get prompt medical attention.

W-2065-1296

Open the rear door.

Disconnect the negative(-) cable (Item 1) [A] from the battery.

Disconnect the positive (+) cable (Item 1) [B] from the battery.

Remove the nuts from the holddown clamp (Item 2) [B] and remove the battery holddown clamp.

Remove the battery from the loader [C].

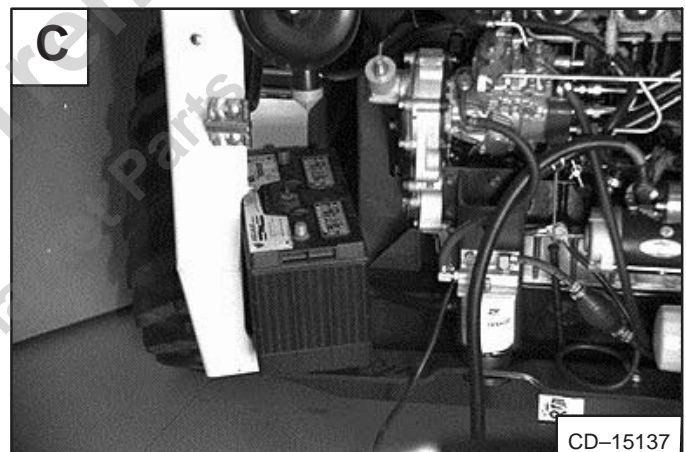
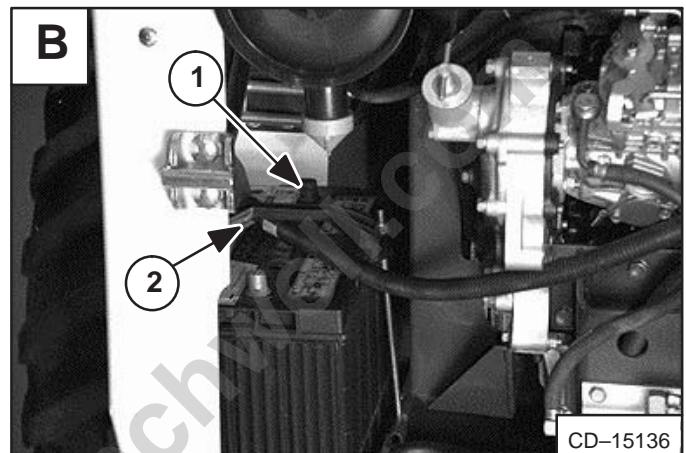
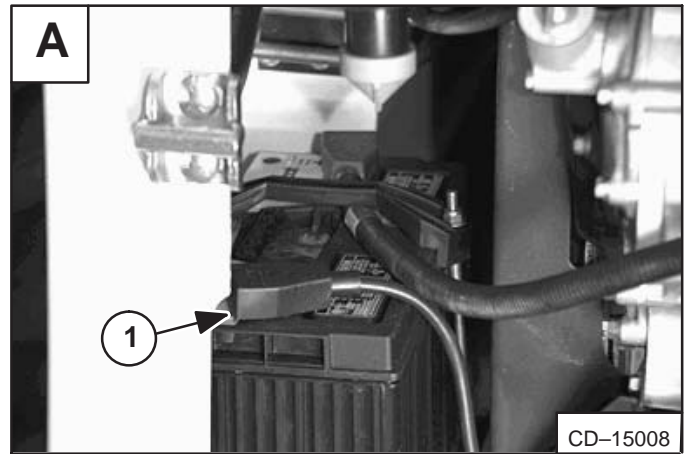

BATTERY (Cont'd)**Removal And Installation (Cont'd)**

Always clean the terminals and cable ends when installing a new battery [A] and [B].

When installing the battery in the loader, do not touch any metal parts with the battery terminal posts.

Connect and tighten the battery cables. Connect the negative (-) cable last to prevent sparks.

**WARNING**

Batteries contain acid which burns eyes and skin on contact. Wear goggles, protective clothing and rubber gloves to keep acid off body.

In case of acid contact, wash immediately with water. In case of eye contact get prompt medical attention and wash eye with clean, cool water for at least 15 minutes.

If electrolyte is taken internally drink large quantities of water or milk. DO NOT induce vomiting. Get prompt medical attention.

W-2065-1296



P-09589



P-09590

Servicing The Electrical System

The battery cables must be clean and the connections tight. Remove acid or corrosion from the battery and cables with a sodium bicarbonate (baking soda) and water solution [C].

Clean the terminals and cable ends as shown in Fig. [A] and [B].

Check the electrolyte level in the battery. Add distilled water as needed.

Put Battery Saver (P/N 6664458) or grease on the battery terminals and cable ends to prevent corrosion.



P-09588

BATTERY (Cont'd)**Using A Booster Battery (Jump Starting)**

WARNING

Batteries contain acid which burns eyes and skin on contact. Wear goggles, protective clothing and rubber gloves to keep acid off body.

In case of acid contact, wash immediately with water. In case of eye contact get prompt medical attention and wash eye with clean, cool water for at least 15 minutes.

If electrolyte is taken internally drink large quantities of water or milk. **DO NOT** induce vomiting. Get prompt medical attention.

W-2065-1296

Keep arcs, sparks, flames and lighted tobacco away from batteries. When *jumping* from booster battery make final connection (negative) at engine frame.

Do not jump start or charge a frozen or damaged battery. Warm battery to 60°F. (16°C.) before connecting to a charger. Unplug charger before connecting or disconnecting cables to battery. Never lean over battery while boosting, testing or charging.

Battery gas can explode and cause serious injury.

W-2066-1296

If it is necessary to use a booster battery to start the engine, **BE CAREFUL!** There must be one person in the operator's seat and one person to connect and disconnect the battery cables.

The ignition must be in the OFF position. The booster battery to be used must be 12 volt.

Connect the end of the first cable (Item 1) [A] to the positive (+) terminal of the booster battery. Connect the other end of the same cable (Item 2) [A] to the positive terminal on the starter solenoid.

Connect the end of the second cable (Item 3) [A] to the negative (-) terminal of the booster battery. Connect the other end of the same cable (Item 4) [A] to the engine.

Keep cables away from moving parts. Start the engine. (Also see *Cold Temperature Starting Condition, Operation & Maintenance Manual.*)

After the engine has started, remove the ground (-) cable (Item 4) [A] first. Remove the cable from the positive terminal on the starter solenoid.

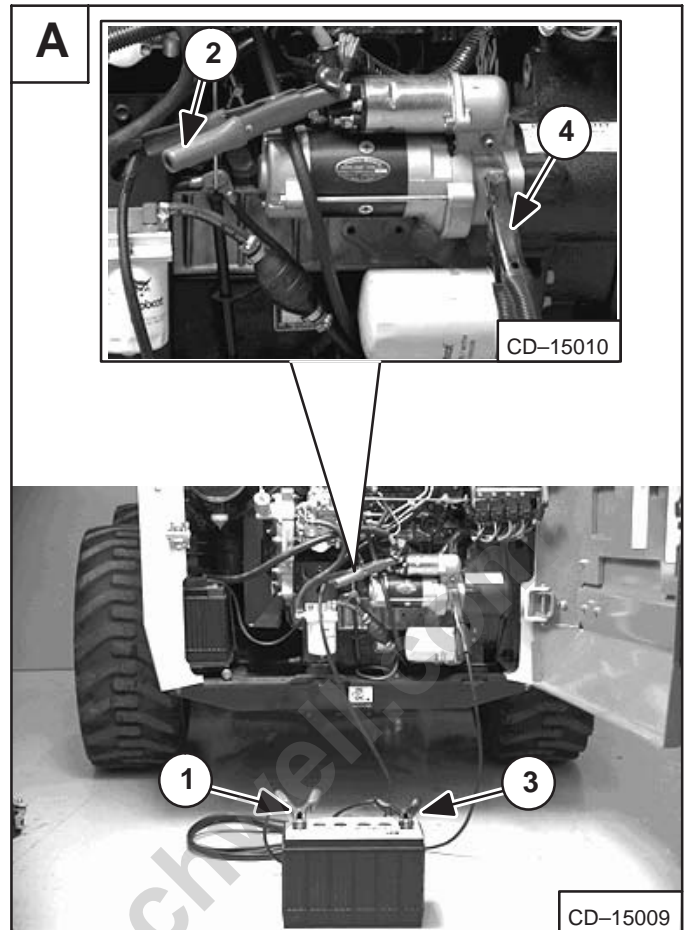

IMPORTANT

Damage to the alternator can occur if:

- Engine is operated with battery cables disconnected.
- Battery cables are connected when using a fast charger or when welding on the loader. (Remove both cables from the battery.)
- Extra battery cables (booster cables) are connected wrong.

I-2023-1285

ALTERNATOR

Alternator Output Test

⚠ WARNING

Put jackstands under the front axles and rear corners of the frame before running the engine for service. Failure to use jackstands can allow the machine to fall or move and cause injury or death.

W-2017-0286

Lift and block the loader (See Page 1-1).

Disconnect the negative (-) cable from the battery.

Disconnect the red wire (Item 1) [A] from the alternator. Connect the wire to the negative (-) side of the ammeter.

Connect the positive (+) side of the ammeter to the output terminal on the alternator (Item 1) [A].

Disconnect the fuel stop solenoid connector.

Connect the negative (-) cable to the battery.

Turn on the lights and crank the engine for 30 seconds to discharge the battery.

Connect the fuel stop solenoid, start the engine and run at 2600 RPM.

If ammeter reading is between 45-55 amps. @ 2600 RPM the alternator is good and no further testing is needed.

If the reading is low, remove the screws and pull the regulator cover away from the alternator and continue testing (below).

Rectifier (Diode) Test

NOTE: The alternator is removed from the loader for clarity purposes.

Disconnect the negative (-) cable from the battery.

Install the wire in their original location on the back of the alternator.

Connect a jumper wire (Item 1) [B] to the alternator output terminal and the regulator terminal.

Connect the battery negative (-) cable.

Start the engine and run at 2600 RPM.

If the reading is within 45-55 amps. @ 2600 RPM replace the rectifier (diode) assembly or replace the alternator.

If the reading is low, do the Alternator Regulator Test.

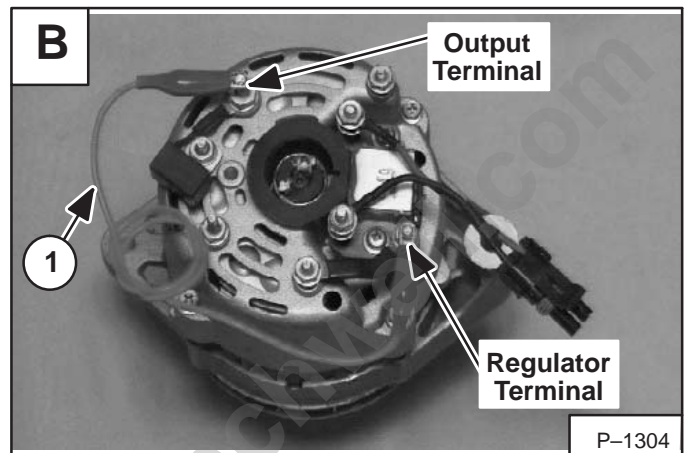
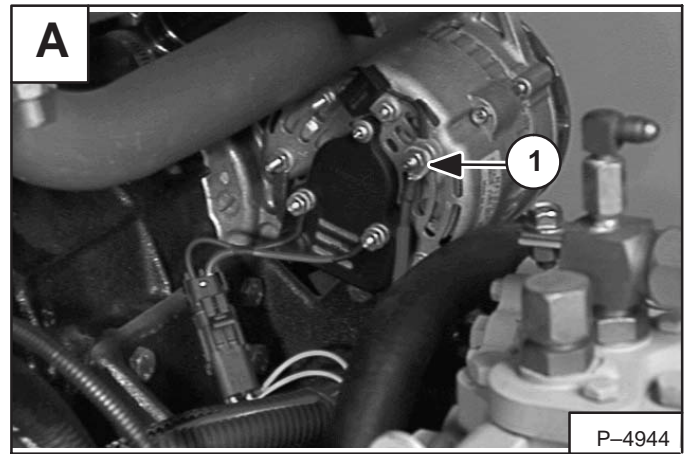

ALTERNATOR (Cont'd)**Alternator Regulator Test**

WARNING

When an engine is running in an enclosed area, fresh air must be added to avoid concentration of exhaust fumes. If the engine is stationary, vent the exhaust outside. Exhaust fumes contain odorless, invisible gases which can kill without warning.

W-2050-1285

Connect the positive (+) voltmeter lead to the positive (+) battery terminal **[A]**.

Connect the negative (-) voltmeter lead to the negative (-) battery terminal **[A]**.

Start the engine and run at 1500–2000 RPM.

The voltmeter should read between 13.9–14.7 volts.

If the reading is low, stop the engine and disconnect the battery negative (-) cable.

NOTE: The alternator is removed from the loader for clarity purposes.

Remove the wires from the back of the alternator.

Remove the regulator cover from the back of the alternator.

Install the wires on the back of the alternator.

Connect a jumper wire (Item 1) **[B]** from the brush terminal to the ground stud.

Connect the negative (-) battery cable and start the engine. Run at 1500 RPM.

If the voltmeter reading is 14.5 or above, replace the regulator.

If the voltmeter reading is below 14.5, repair or replace the alternator.

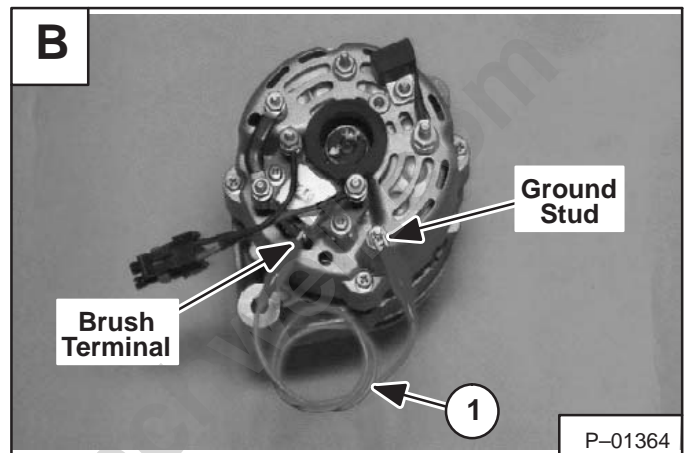
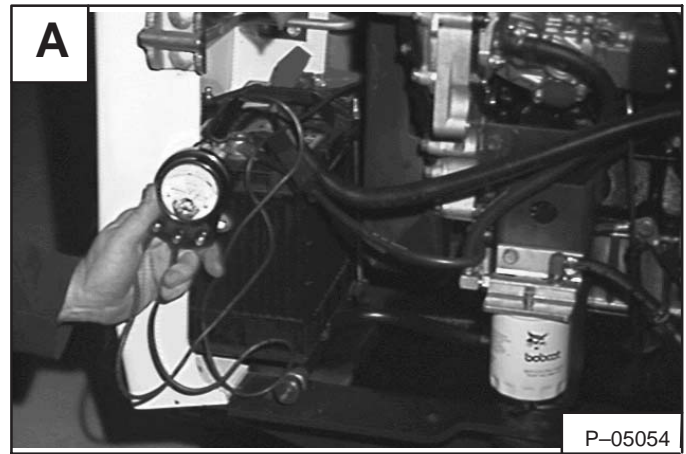

ALTERNATOR**Removal And Installation**

NOTE: The engine/hydrostatic pump assembly is shown removed for photo clarity purpose only.

**WARNING**

Never work on a machine with the lift arms up unless the lift arms are secured by an approved lift arm support device. Failure to use an approved lift arm support device can allow the lift arms or attachment to fall and cause injury or death.

W-2059-0598

IMPORTANT

Damage to the alternator can occur if:

- Engine is operated with battery cables disconnected.
- Battery cables are connected when using a fast charger or when welding on the loader (Remove both cables from the battery).
- Extra battery cables (booster cables) are connected wrong.

I-2023-1285

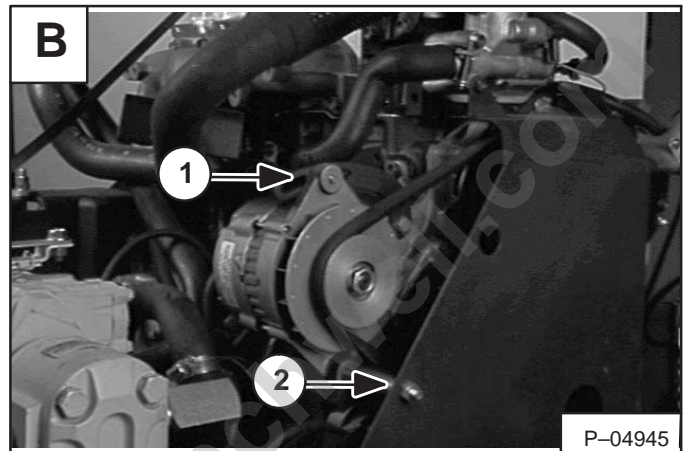
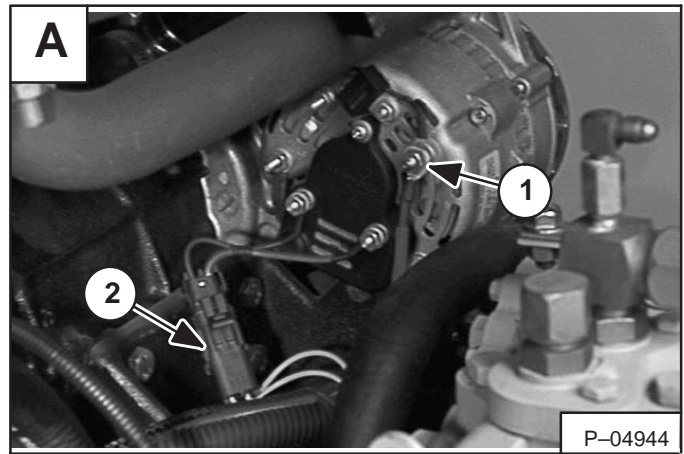

Raise the operator cab. (See Page 1-1.)

Open the rear door. Disconnect the negative (-) battery cable.

Disconnect the orange wire (Item 1) [A] from the alternator.

Disconnect the wiring harness connector (Item 2) [A].

Loosen the adjustment bolt (Item 1) [B].

Remove the alternator belt.

Remove the adjustment bolt (Item 1) [B].

Remove the mounting bolt, nut and spacer (Item 2) [B].

Remove the alternator.

ALTERNATOR (Cont'd)

Disassembly

(Motorola or Prestolite 30 Amp., Enclosed)

Disassemble the alternator as shown in Fig. [A].

Remove the regulator cover and regulator.

Remove the four bolts holding halves together.

Pry the halves apart.

Use a soft jaw vise to hold rotor while removing pulley nut.

Remove front case half from the rotor using a plastic hammer.

Unsolder the stator leads from the rectifier. Remove the stator.

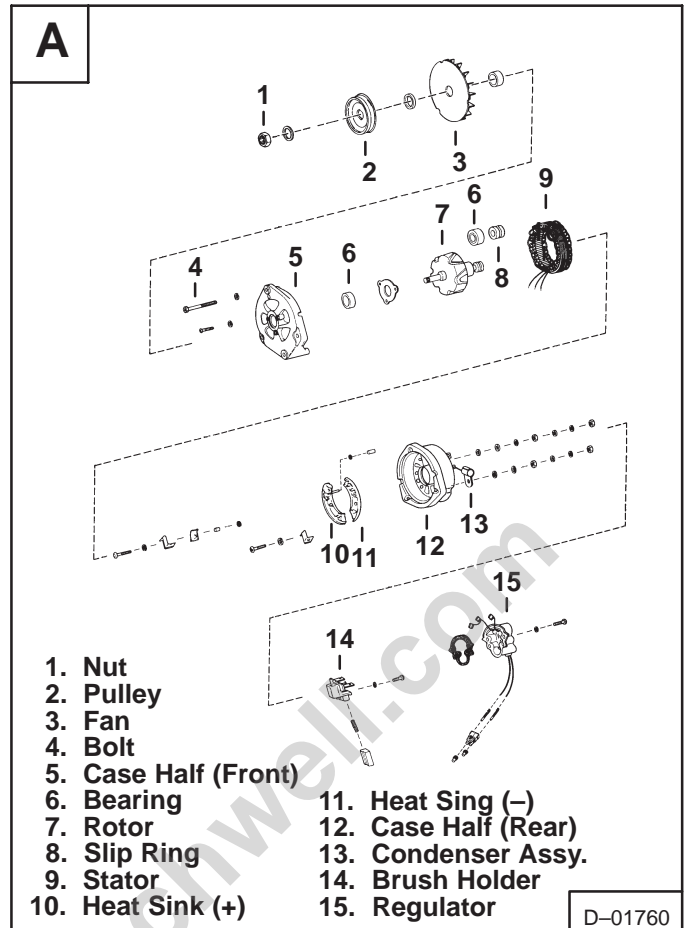

Stator Continuity Test

Use an ohmmeter to test the stator.

Touch the probes to two of the bare stator wires [B].

Move one of the probes to the third wire.

The readings should be the same.

If there is no continuity, replace the stator.

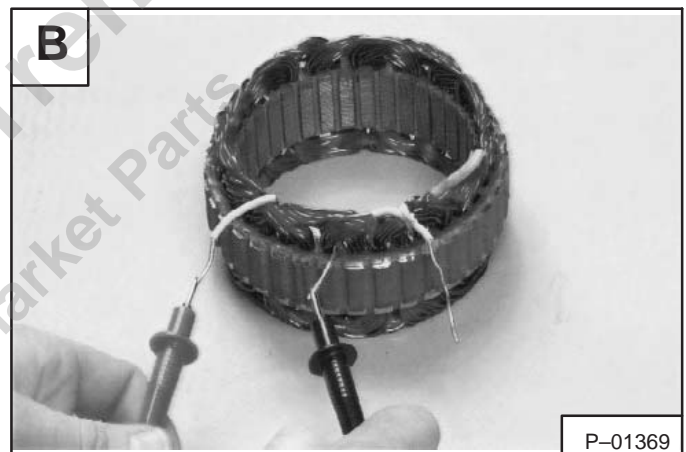

Stator Ground Test

Touch one probe to a bare stator lead and the other probe to the bare metal surface of the stator [C].

There should be no continuity.

Replace the stator if there is continuity.

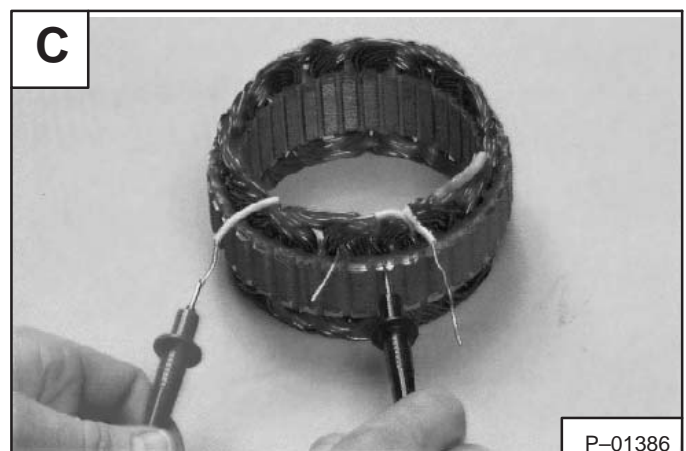

ALTERNATOR (Cont'd)**Rotor Continuity Test**

Touch the probes to the slip rings [A].

The ohmmeter should read between 3.0–33.0 ohms.

If there is no continuity replace the rotor.

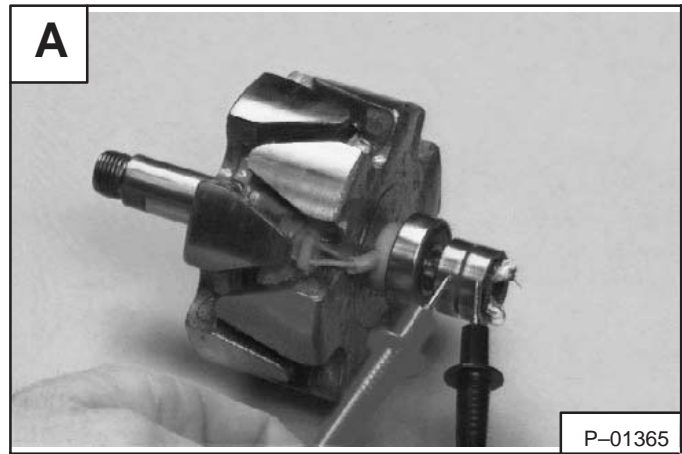
**Rotor Ground Test**

Touch one probe to one of the slip rings and the other probe to the rotor shaft [B].

There should be no continuity.

Replace the rotor if there is continuity.

**Rectifier Continuity (Diode) Test**

NOTE: In the diode tests there should be continuity in one direction only. If the diode being tested shows no continuity or continuity in both directions, replace the rectifier assembly.

Touch the probes to the terminals of each diode and read the meter [C].

Reverse the probes to check the diode in the other direction.

There should be continuity in one direction only.

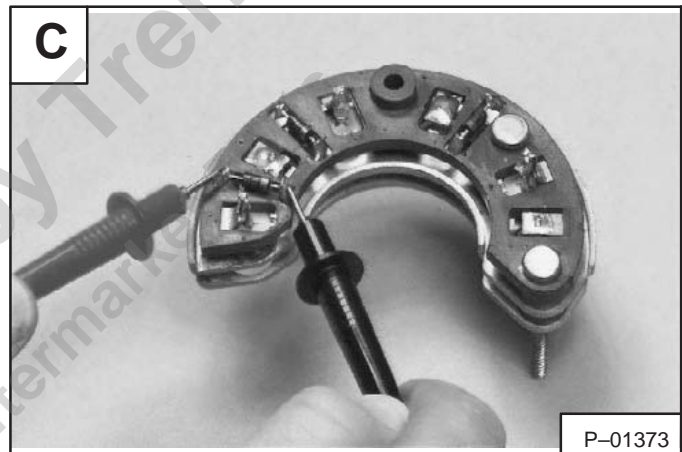

Touch one probe to the diode and the other probe to the connected heat sink and read the meter [D].

Reverse the probes to check the diode in the other direction.

There should be continuity in one direction only.

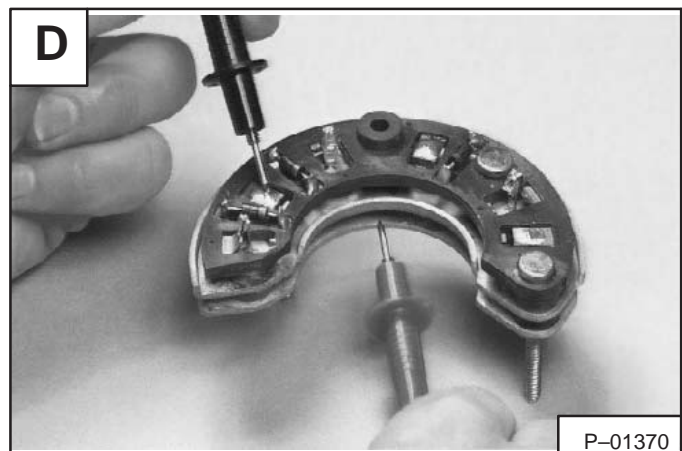

ALTERNATOR (Cont'd)

Assembly

Reverse the order of disassembly.

Place the rotor in soft jaws when tightening the shaft nut. Tighten to 50 ft.-lbs. (68 Nm) torque **[A]**.

Install the rear case half and the remaining parts.

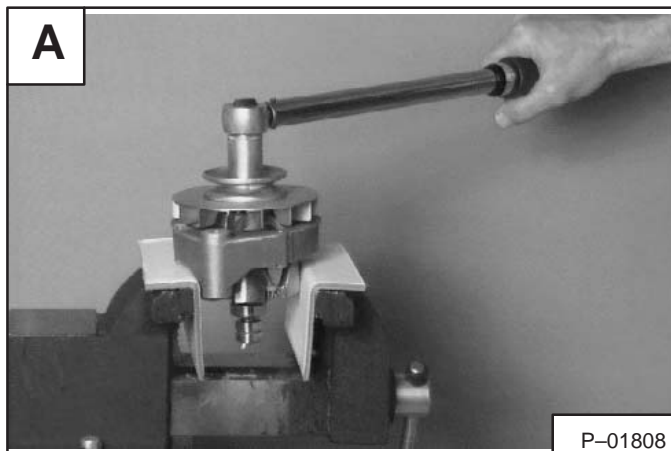

Provided for Free by Trenchwell.com
Shop Aftermarket Parts

STARTER**Checking The Starter**

The key switch must be in the OFF position.

The battery must be at full charge.

The cable connections on the battery must be clean and tight.

Connect a jumper wire between S terminal and BAT terminal **[A]**.

If the starter turns but does not turn the engine, the starter drive has a defect.

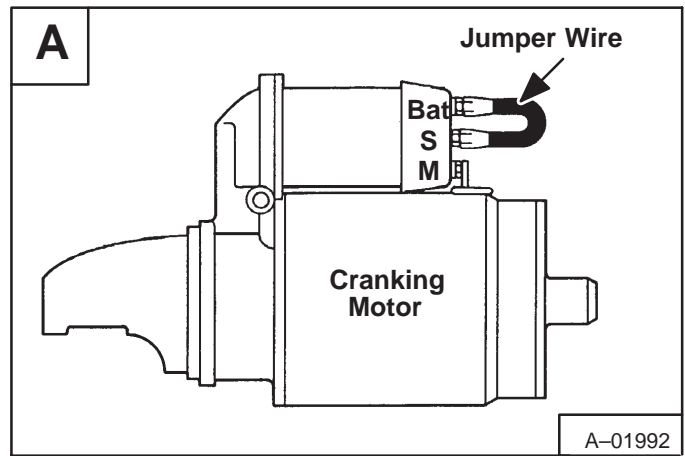

Connect a jumper wire between the M terminal and the BAT terminal **[B]**.

If the starter turns, the defect is in the solenoid.

If the starter does not turn, the starter is defective.

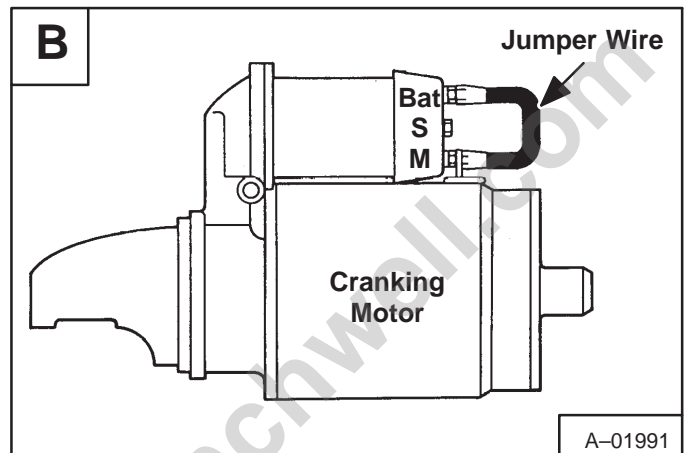

STARTER (Cont'd)

Removal And Installation

Disconnect the negative (-) cable from the battery.

Disconnect the positive (+) cable (Item 1) **[A]** and starter wires from the starter solenoid.

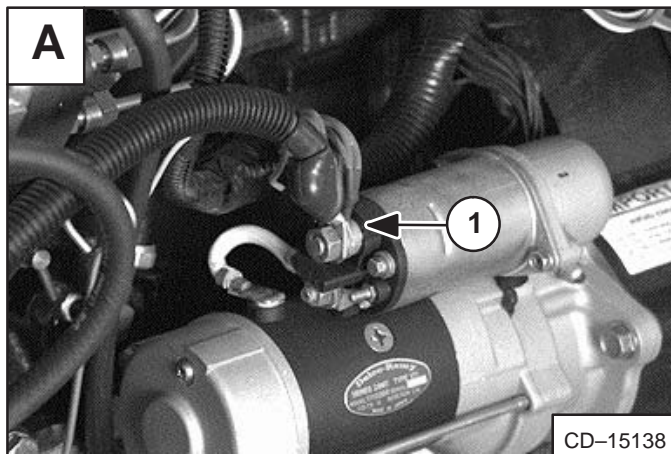

Remove the starter mounting bolt (Item 1) **[B]** and engine harness ground wires from the starter.

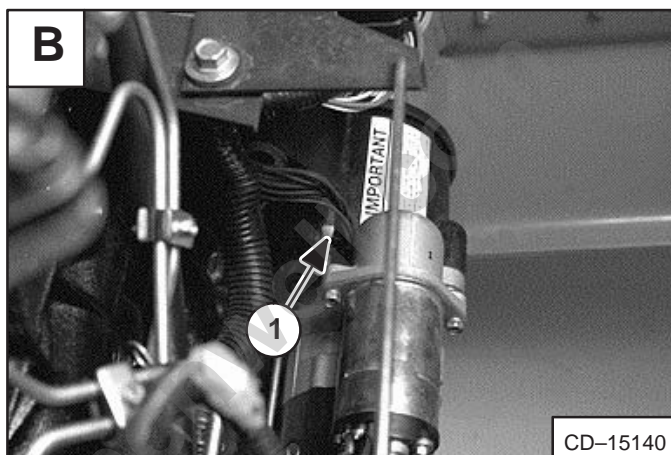

Remove the other two mounting bolts (Item 1) **[C]**.

Remove the starter from the engine.

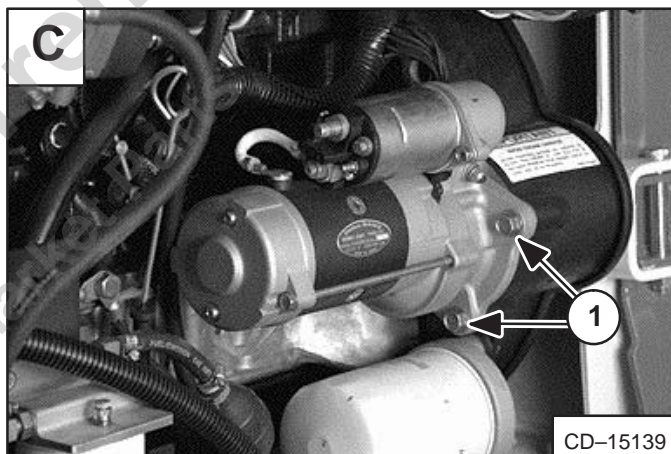

Provided for Free by
Shop Aftermarket

STARTER (Cont'd)

Parts Identification

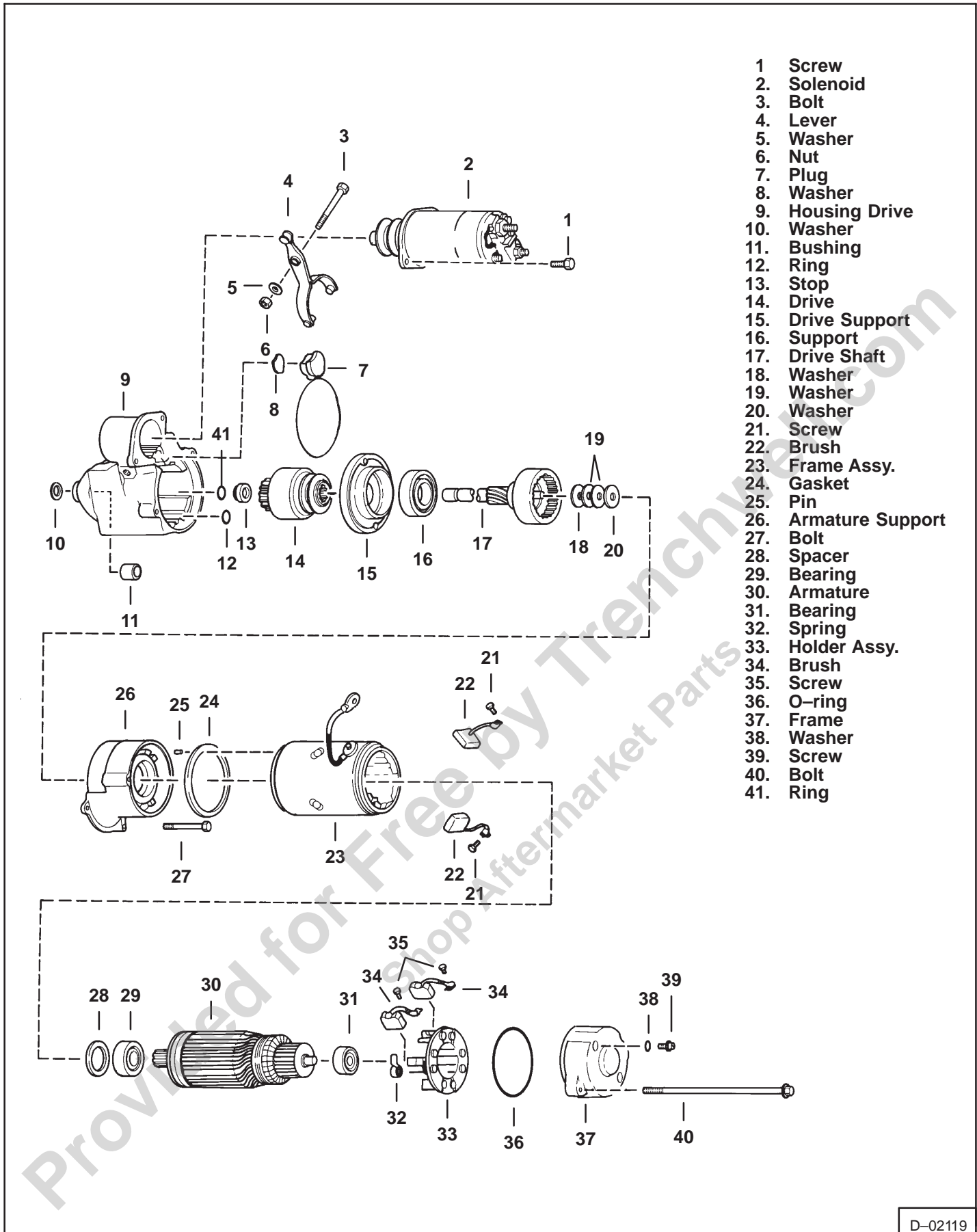

1. Screw
2. Solenoid
3. Bolt
4. Lever
5. Washer
6. Nut
7. Plug
8. Washer
9. Housing Drive
10. Washer
11. Bushing
12. Ring
13. Stop
14. Drive
15. Drive Support
16. Support
17. Drive Shaft
18. Washer
19. Washer
20. Washer
21. Screw
22. Brush
23. Frame Assy.
24. Gasket
25. Pin
26. Armature Support
27. Bolt
28. Spacer
29. Bearing
30. Armature
31. Bearing
32. Spring
33. Holder Assy.
34. Brush
35. Screw
36. O-ring
37. Frame
38. Washer
39. Screw
40. Bolt
41. Ring

D-02119

STARTER (Cont'd)

Disassembly And Assembly

Remove the starter thru-bolts [A].



Remove the screws for the brush holders [B].

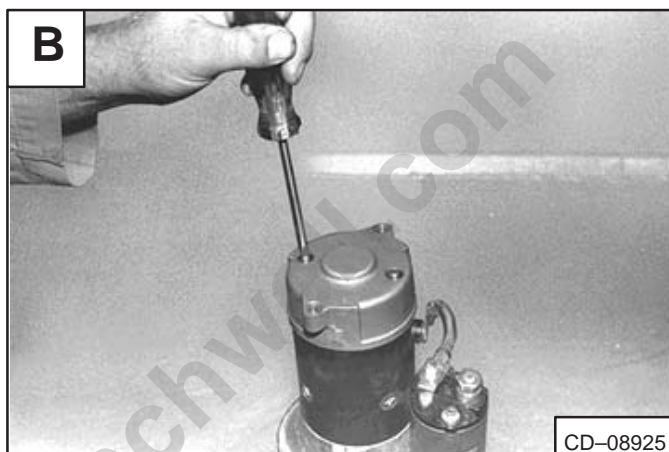

Remove the starter end cap [C].



Remove the starter housing/armature assembly from the reduction gear drive [D].



STARTER (Cont'd)

Disassembly And Assembly (Cont'd)

Remove the armature and brushes from the starter housing [A].

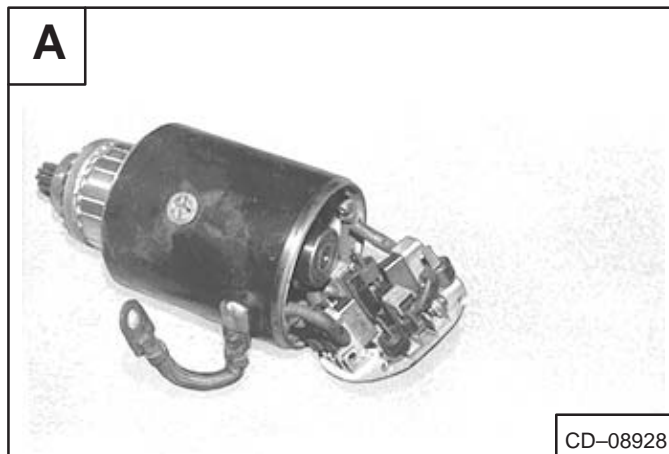

Remove the bolts from the reduction gear housing [B].

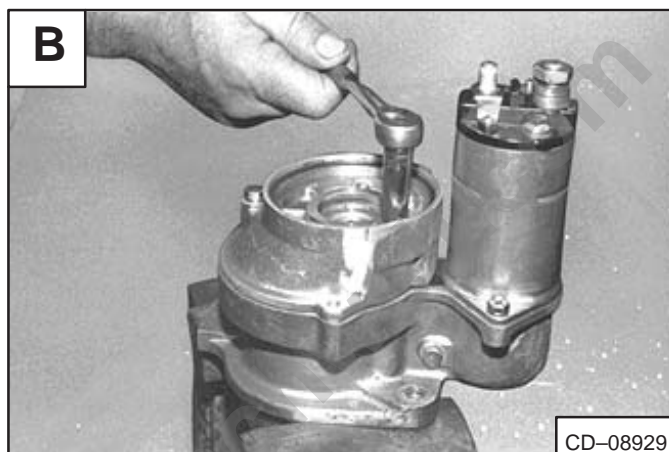

Remove the reduction gear housing [C].

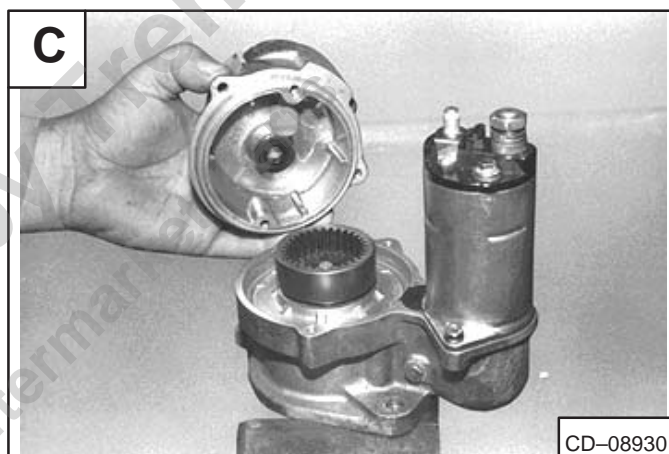

Provided for Free by
Shop Aftermarket

STARTER (Cont'd)

Cleaning And Inspection

Use a brush and air pressure to clean the drive, field coils, armature and starter housing.

NOTE: DO NOT use solvent to clean the drive assembly. The solvent will remove the lubricant and the drive will slip.

Check the following items:

Armature

- Broken or burned insulation
- Loose connections at commutator
- Open or grounded circuits **[A]** & **[B]**
- Worn shaft or bearings
- Rough commutator

Brush Holders

- Broken springs
- Broken insulation
- Spring tension

Field Coils

- Broken or burned insulation
- Electrical continuity
- Brush connections

Drive Gears

- Worn teeth
- Tooth engagement

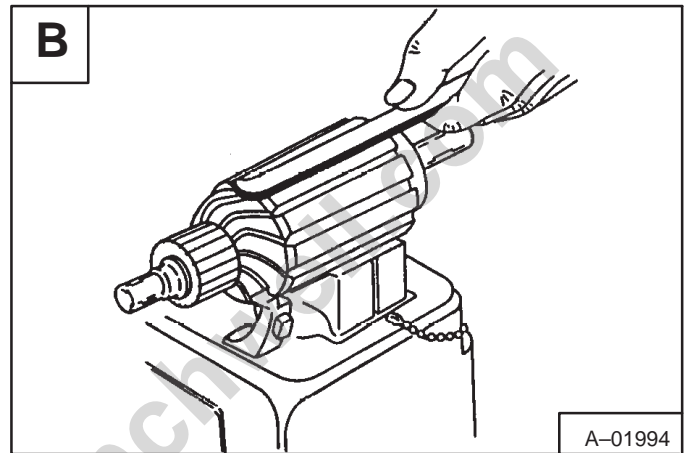
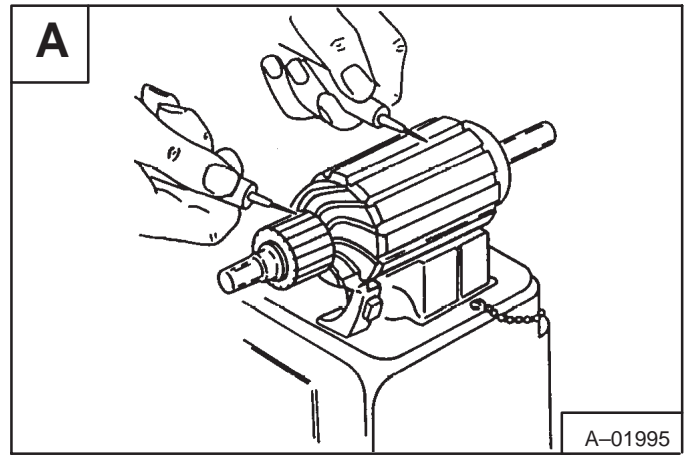

Provided for Free by Trencher.com
Shop Aftermarket Parts

STANDARD INSTRUMENT PANEL**Removal And Installation**

Pry the rubber light mount loose from the operator cab (both sides) **[A]**.



Lower the light from the operator cab and locate the three instrument panel mounting bolts (Item 1) **[B]** (both sides).

Remove the three mounting bolts (Item 1) **[B]**.

Installation: Be careful not to overtighten the instrument panel mounting bolts to prevent stripping the threaded holes in the panels.

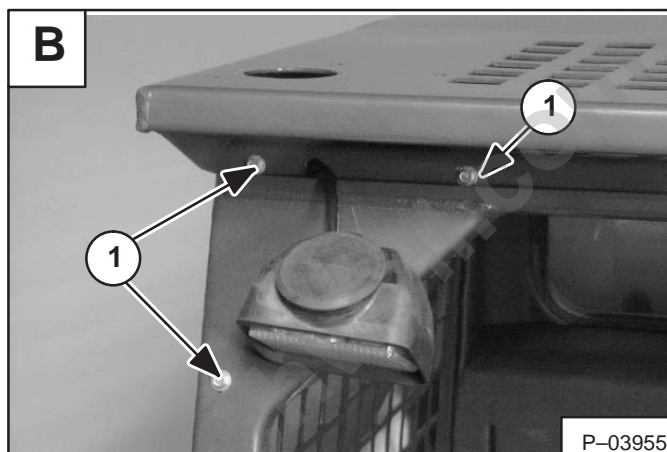

Pull the left instrument panel down and disconnect the wire harness connectors from the panel. Remove the panel **[C]**.

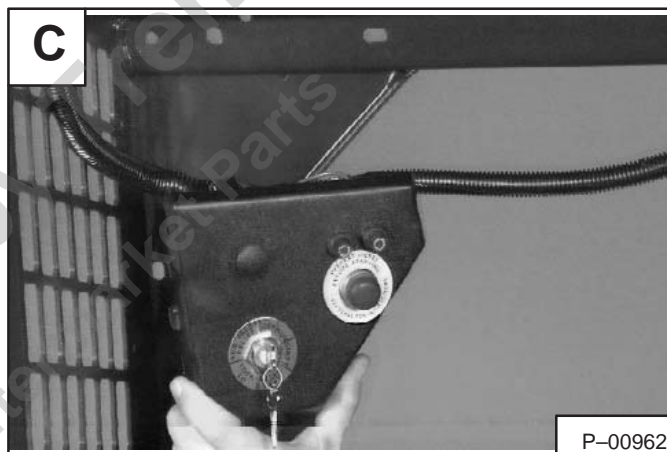

Repeat steps **[A]** and **[B]**. Pull the right instrument panel down and disconnect the wire harness connectors from the panel. Remove the panel **[D]**.

Reverse the removal procedure to install the instrument panel.



FRONT LIGHTS

Removal And Installation

The front lights are mounted in the upper corners of the operator cab [A].



Pry the rubber light mount free from the operator cab [B].

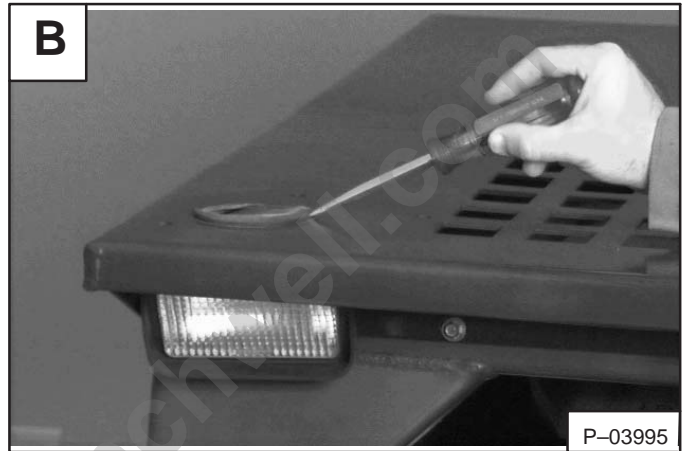

Pull the light down and remove the three mounting bolts (Item 1) [C] from the instrument panel.

Disconnect the front light connector from the instrument panel. Remove the front light from the operator cab.

Reverse the removal procedure to install the front light.

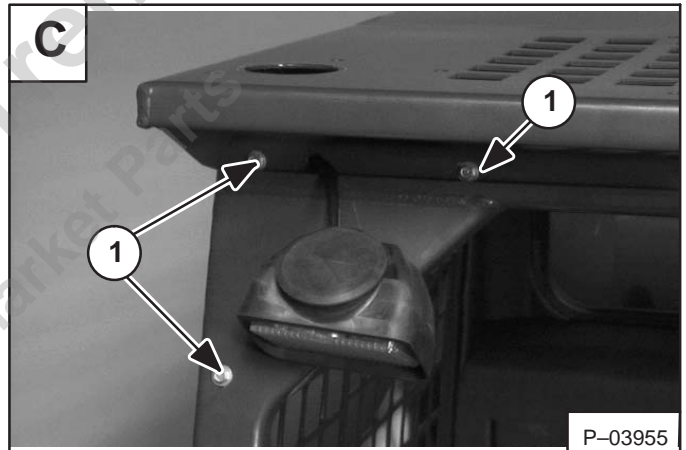

STEERING LEVER CONTROL HANDLE (Early Series)

Disassembly And Assembly

Remove all the screws and nuts from the control handle [A].

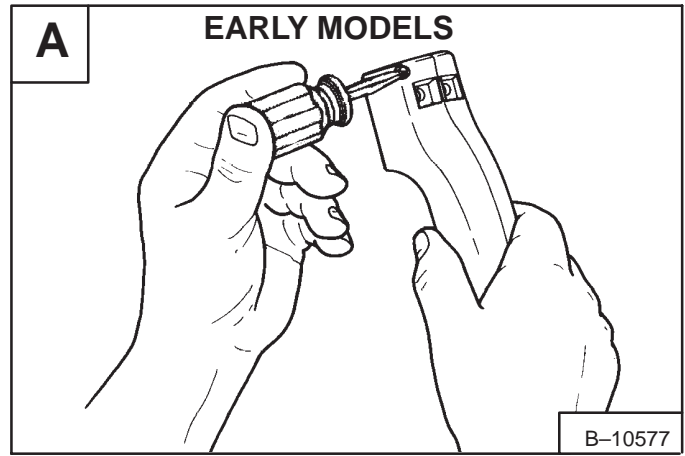

Remove one side of the control handle [B].

Disconnect the wires and remove the other half of the handle with the switch plate.

Assembly: When connecting the electrical wires to the switches, see *AUXILIARY WIRING DIAGRAM* for correct installation.

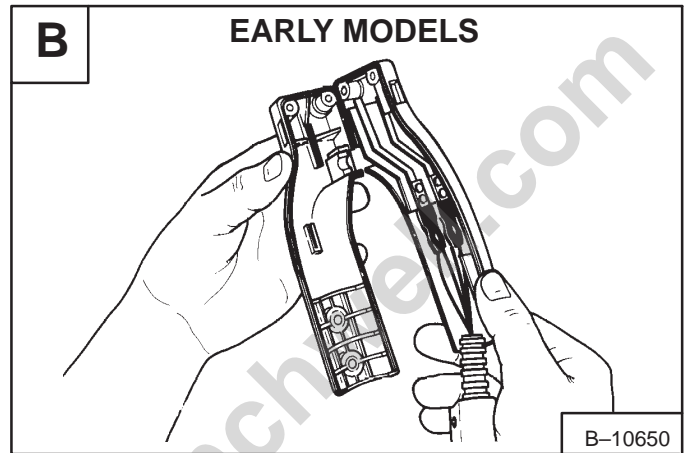

ENGINE SERVICE

	Page Number
AIR CLEANER HOUSING	
Removal And Installation	7-8
BELT SHIELD	
Removal And Installation	7-38
CAMSHAFT	
Camshaft Bearings	7-79
Checking	7-78
Removal And Installation	7-78
Tappets	7-79
Tappet Installation	7-80
CAMSHAFT GEAR	
Removal And Installation	7-76
COOLANT RECOVERY TANK	
Removal And Installation	7-9
CRANKSHAFT	
Checking The Crankshaft	7-67
Checking Tuffriding Coating	7-67
Removal And Installation	7-67
CRANKSHAFT GEAR	
Removal And Installation	7-69
CYLINDER LINERS	
Checking The Cylinder Bore	7-63
Installation	7-63
Removal	7-63
CYLINDER HEAD	
Cylinder Head Surface Alignment	7-52
Exhaust Manifold	7-52
Removal And Installation	7-51
ENGINE	
Removal And Installation	7-30
ENGINE COMPRESSION	
Checking	7-41
ENGINE MOUNTS	
Removal And Installation	7-39
ENGINE MUFFLER	
Removal And Installation	7-7
ENGINE SPEED CONTROL	
Removal And Installation	7-6

**ENGINE
SERVICE**

ENGINE SERVICE (Cont'd)

	Page Number
FAN GEARBOX/BLOWER HOUSING	
Removal And Installation	7-13
FAN DRIVE TENSION PULLEY	
Removal And Installation	7-12
FAN GEARBOX	
Assembly	7-22
Checking Backlash	7-29
Disassembly	7-18
Parts Identification	7-17
FLYWHEEL	
Flywheel Ring Gear	7-37
Removal And Installation	7-37
FUEL INJECTOR NOZZLES	
Checking	7-49
Removal And Installation	7-48
FUEL INJECTION PUMP	
Description	7-42
Removal And Installation	7-42
Timing The Injection Pump	7-46
FUEL INJECTION PUMP IDLER GEAR	
Bearing Installation	7-75
Removal And Installation	7-75
GLOW PLUGS	
Checking The Glow Plugs	7-40
Removal And Installation	7-40
IDLER GEAR AND HUB	
Checking	7-73
Removal	7-73
Installation	7-74
MAIN BEARINGS	
Description	7-64
Crankshaft End Play	7-66
Installation	7-65
Removal	7-64
OIL PAN	
Removal	7-81
Installation	7-81

ENGINE SERVICE (Cont'd)

	Page Number
OIL PUMP	
Checking	7-82
Gear Replacement	7-83
Oil Filter Housing And Block	7-84
Oil Pump Relief Valve	7-84
Removal And Installation	7-82
Rotor Replacement	7-84
 PISTON AND CONNECTING ROD	
Assembly	7-61
Checking	7-58
Disassembly	7-57
Installation	7-62
Removal	7-57
 RADIATOR	
Removal And Installation	7-10
 ROCKER ARM AND SHAFT	
Checking Rocker Arms And Push Rods	7-56
Disassembly And Assembly	7-56
 TIMING GEARCASE	
Removal And Installation	7-77
 TIMING GEARCASE COVER	
Removal And Installation	7-71
 TIMING GEARCASE COVER SEAL	
Removal And Installation	7-70
 THERMOSTAT	
Checking The Thermostat	7-88
Removal And Installation	7-88
 TROUBLESHOOTING	
Chart	7-5
 VALVE CLEARANCE	
Adjustment	7-41
 VALVE, VALVE SEAT AND GUIDE	
Installation	7-53
Reconditioning The Valve And Valve Seat	7-53
Removal	7-53
Valve Guide	7-54
Valve Seat Insert	7-54
Valve Spring	7-55
 WATER JACKET TUBE	
Removal And Installation	7-89
 WATER PUMP	
Assembly	7-86
Disassembly	7-85
Removal And Installation	7-85



Provided for Free by www.youfixthis.com
Shop Aftermarket Parts at www.frenchwell.com

TROUBLESHOOTING**Chart**

The following troubleshooting chart is provided for assistance in locating and correcting problems which are most common. Many of the recommended procedures must be done by authorized Bobcat Service Personnel only.

PROBLEM	CAUSE
Slow cranking speed.	1, 2, 3, 4
Engine will not start.	2, 5, 6, 7, 8, 9, 11, 12, 13, 14, 15, 16, 17, 19, 27, 28, 29
Difficult to start.	5, 7, 8, 9, 10, 11, 12, 13, 15, 16, 17, 18, 19, 20, 25, 27, 28, 29
No power for engine.	8, 9, 10, 11, 12, 13, 15, 16, 17, 18, 20, 21, 22, 23, 27, 28, 29
Engine is mis-firing.	8, 9, 11, 12, 13, 15, 16, 17, 21, 22, 24, 25, 26, 28
Too much fuel consumption.	10, 12, 13, 15, 16, 17, 19, 20, 21, 23, 24, 25, 27, 28, 29
Black exhaust.	10, 12, 13, 15, 16, 17, 19, 20, 21, 23, 24, 25, 27, 28, 29
Blue/white exhaust.	4, 10, 15, 16, 17, 21, 23, 27, 29, 30, 50
Low oil pressure.	4, 31, 32, 33, 34, 35, 37, 39, 52
Engine knocking.	13, 15, 16, 19, 22, 24, 25, 27, 29, 31, 40, 41, 53
Engine running rough.	7, 8, 9, 10, 11, 12, 13, 17, 18, 22, 24, 25, 26, 29, 40, 53
Vibration.	12, 13, 17, 21, 22, 25, 26, 29, 40, 42, 43
High oil pressure warning.	4, 33, 36
Overheating.	10, 12, 13, 15, 16, 20, 21, 40, 44, 45, 46, 47, 48, 51
Too much crankcase pressure.	22, 27, 29, 30, 40, 49
Poor compression.	10, 16, 21, 24, 25, 27, 28, 29, 30, 41, 53
Start and stop.	9, 10, 11

KEY TO CORRECT THE CAUSE

- | | |
|---|---|
| 1. Battery capacity low. | 28. Worn valve and seats. |
| 2. Bad electrical connections. | 29. Broken, worn or sticking piston rings. |
| 3. Faulty starter motor. | 30. Worn valve stems or guides. |
| 4. Incorrect grade of oil. | 31. Worn or damaged bearings. |
| 5. Low cranking speed. | 32. Not enough oil in the oil pan. |
| 6. Fuel tank empty. | 33. Switch/sensor is defective. |
| 7. Faulty stop control operation. | 34. Oil pump worn. |
| 8. Plugged fuel line. | 35. Pressure relief valve is sticking open. |
| 9. Plugged fuel filter. | 36. Pressure relief valve is sticking closed. |
| 10. Restriction in the air cleaner. | 37. Broken relief valve spring. |
| 11. Air in the fuel system. | 38. Faulty suction pipe. |
| 12. Faulty fuel injection pump. | 39. Plugged oil filter. |
| 13. Faulty fuel injectors. | 40. Piston seizure. |
| 14. Broken injection pump drive. | 41. Incorrect piston height. |
| 15. Incorrect injection pump timing. | 42. Faulty engine mounting. |
| 16. Incorrect valve timing. | 43. Incorrect alignment of flywheel. |
| 17. Poor compression. | 44. Faulty thermostat. |
| 18. Plugged fuel tank vent. | 45. Restriction in water jacket. |
| 19. Incorrect grade of fuel. | 46. Loose alternator belt. |
| 20. Exhaust pipe restriction. | 47. Plugged radiator. |
| 21. Cylinder head gasket leaking. | 48. Faulty water pump. |
| 22. Overheating. | 49. Plugged breather pipe. |
| 23. Cold running. | 50. Damaged valve stem oil deflectors. |
| 24. Incorrect tappet adjustment. | 51. Coolant level too low. |
| 25. Sticking valves. | 52. Plugged oil pump pipe strainer. |
| 26. Incorrect high pressure fuel pipes. | 53. Broken valve spring. |
| 27. Worn cylinder bores. | |

ENGINE SPEED CONTROL

Removal And Installation

Raise the operator cab. (See Page 1-1.)

Remove the two mounting bolts (Item 1) [A] and nuts from the speed control mounting bracket.

Installation: Tighten the bolts (Item 2) [A] evenly until the speed control lever moves back and forth at a comfortable tension.

Pull the speed control away from the loader frame and disconnect the speed control rod (Item 1) [B] from the control.

Installation: Be sure to install the control rod in the bottom hole of the speed control.

Installation: Install the stop bracket (Item 1) [C] in the same location. It is necessary for the front and rear stop on the bracket to be located correctly.

Reverse the removal procedure to install the engine speed control.

Loosen the two control lever mounting bolts and remove the mounting nuts (Item 2) [C].

Do not lubricate the engine speed control.

Replace any worn or damaged parts if necessary.

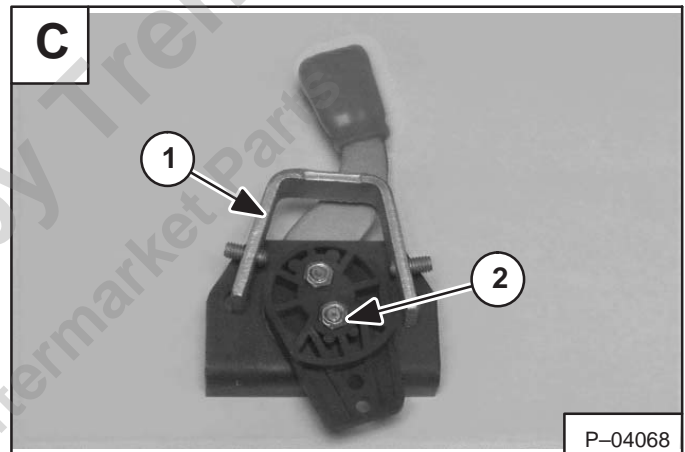
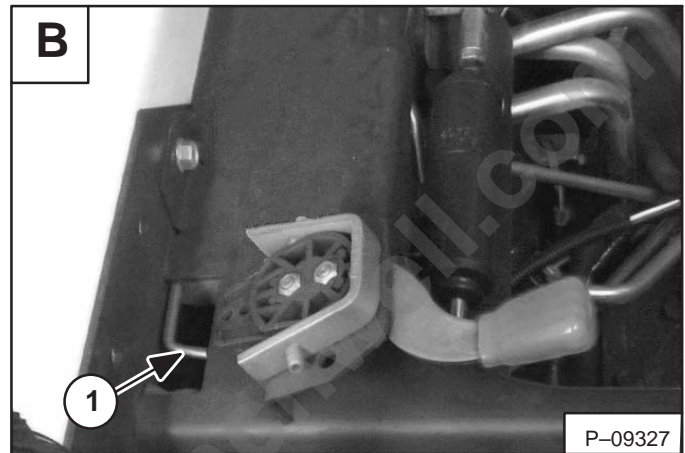
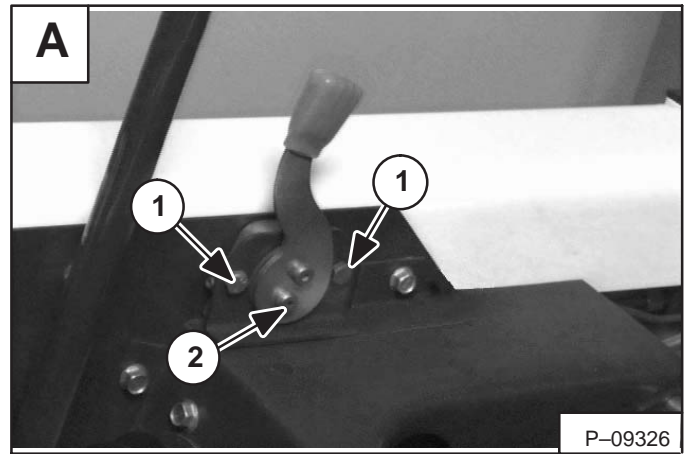

ENGINE MUFFLER

Removal And Installation

Open the rear door.

Raise the rear grill.

Remove the air cleaner. (See Page 7-8.)

Loosen the exhaust pipe clamp (Item 1) [A].

Disconnect the exhaust pipe from the muffler.

Remove the mounting bolt (Item 1) [B] from the muffler (both sides).

Remove the muffler from the loader.

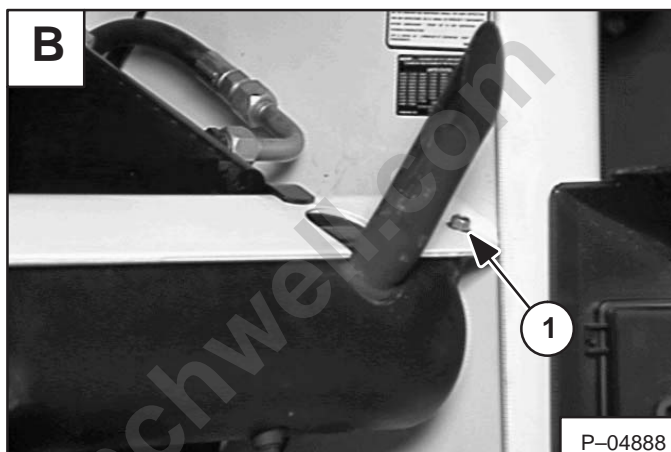
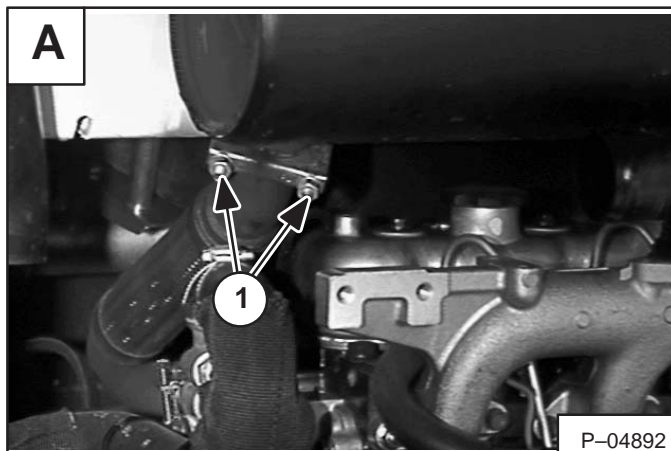

Provided for Free by Trenchwre.com
Shop Aftermarket Parts

AIR CLEANER HOUSING**Removal And Installation**

Loosen the hose clamp (Item 1) [A].

Disconnect the hose from the intake manifold.

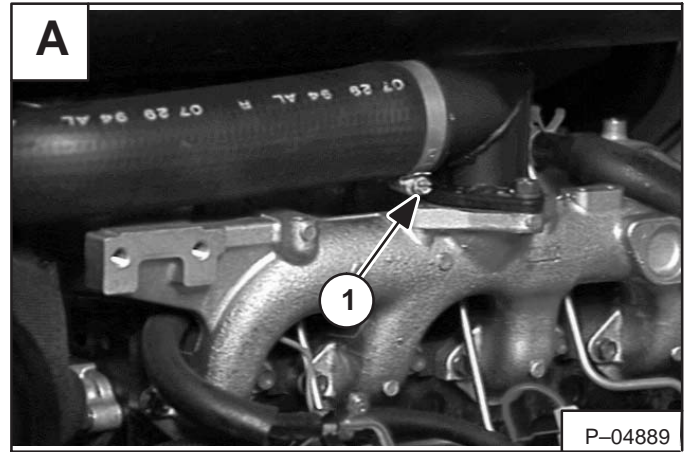

Loosen the hose clamp (Item 1) [B].

Disconnect the intake hose from the air cleaner housing.

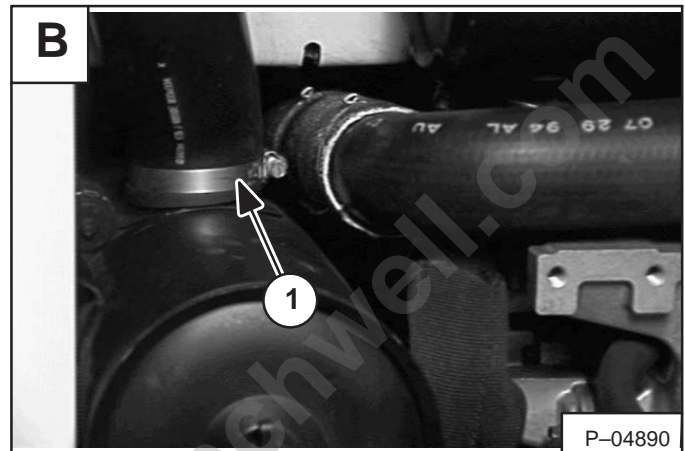

NOTE: The manual indicator (Item 1) [C] is equipped on the 853 standard loader only.

Remove the two mounting bolts (Item 2) [C] (at the top) and one mounting bolt at the bottom of the housing.

Remove the air cleaner housing.

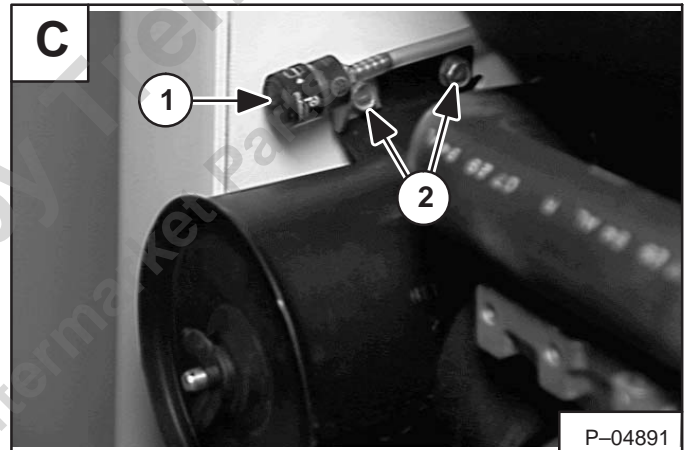

NOTE: Disconnect the wires (Item 1) [D] from the sensor at the rear of the air cleaner housing. The sensor is equipped on 853 BOSS® option loaders only.

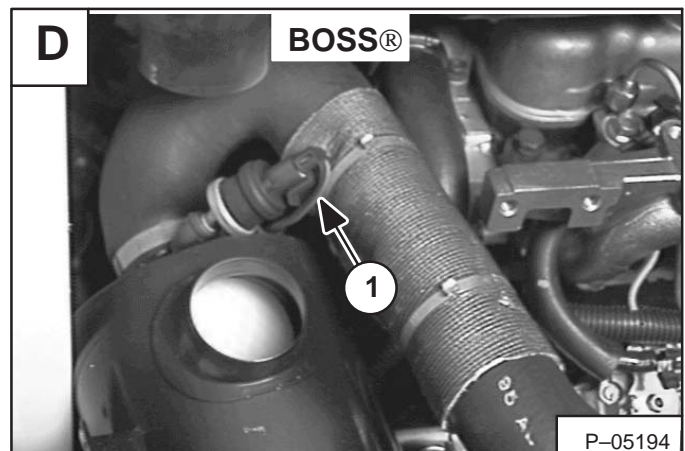

COOLANT RECOVERY TANK

Removal And Installation

Open the rear door.

Raise the rear grill.

Lift the coolant recovery tank from the bracket [A].

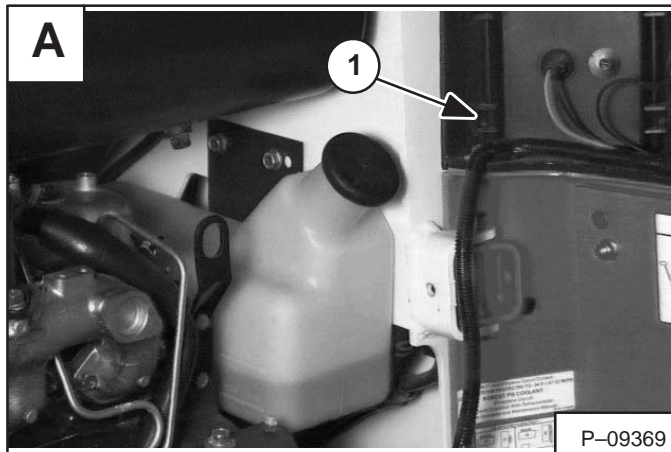

Disconnect the overflow hose (Item 1) [B].



Remove the two mounting bolts (Item 1) [C] from the recovery tank mounting bracket.

Remove the mounting bracket.

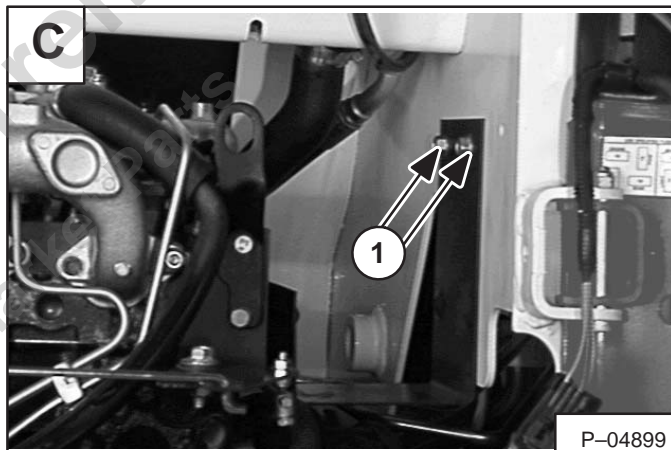

Provided for Free by Techwell.com
Shop Aftermarket

RADIATOR

Removal And Installation

Open the rear door.

Remove the rear grill. (See Page 5–1.)

Remove the oil cooler. (See Page 3–1.)

Remove the engine muffler. (See Page 7–7.)

Loosen the radiator cap.

Connect a hose to the engine block drain (Item 1) [A].

Open the block drain (Item 1) [A] and drain coolant into a container.

NOTE: Early S/N Loaders use a hex plug in this location for the drain.

Disconnect the hose (Item 1) [B].

Disconnect the hose (Item 1) [C].

Remove the radiator mounting bolts (Item 1) [D] (both sides).

Installation: Mix coolant in a separate container. (See *Specifications* for correct capacity Page 9–1.)

Propylene Glycol

Add premixed coolant: 47% water and 53% propylene glycol to the recovery tank if the coolant level is low.

One gallon and one pint of propylene glycol mixed with one gallon of water is the correct mixture of coolant to provide a -34°F (-37°C) freeze protection.

Use a refractometer to check the condition of propylene glycol in your cooling system.

Ethylene Glycol

Add premixed coolant: 50% water and 50% ethylene glycol to the recovery tank if the coolant level is low.

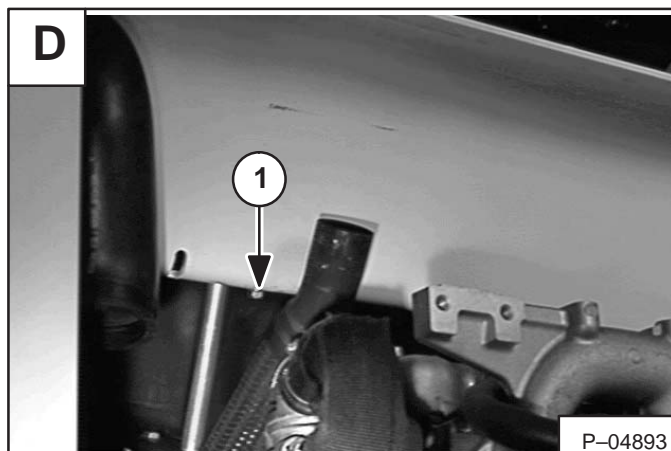
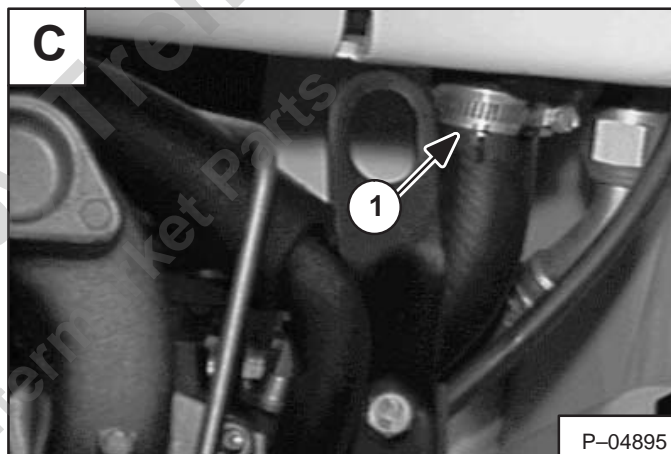
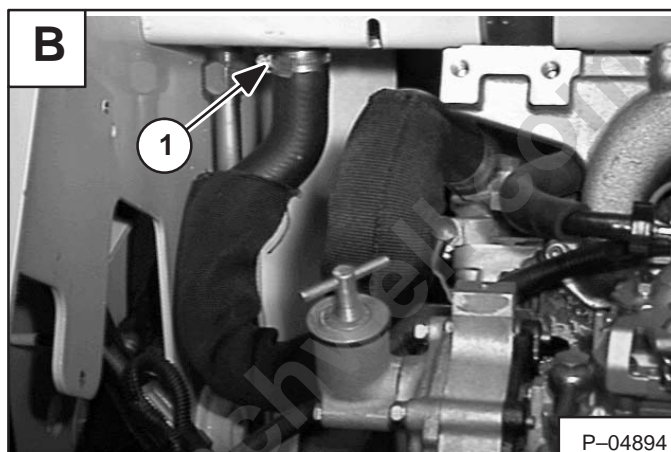
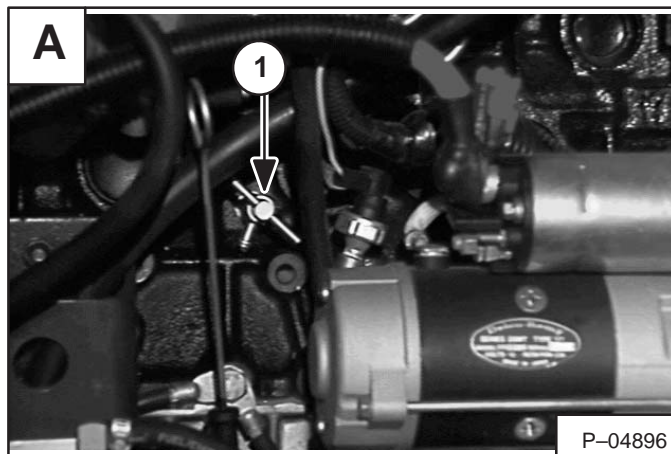

RADIATOR (Cont'd)

Removal And Installation (Cont'd)

Disconnect the over-fill hose (Item 1) [A].

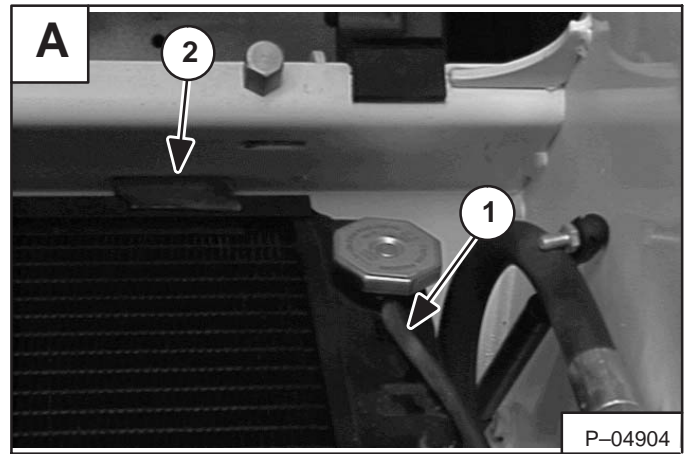

If so equipped, disconnect the wires from the water level sensor (Item 1) [B].

Remove the radiator from the loader.

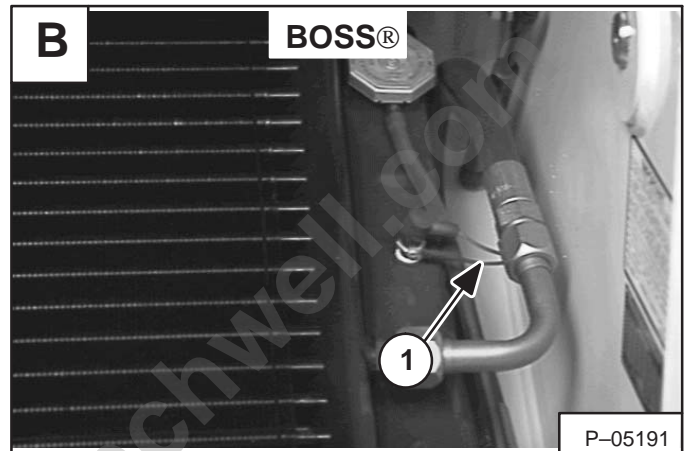

Installation: Be sure the rubber bumpers (Item 2) [A] are located at each side (Item 1) [C] before installing the radiator tabs into the loader frame.

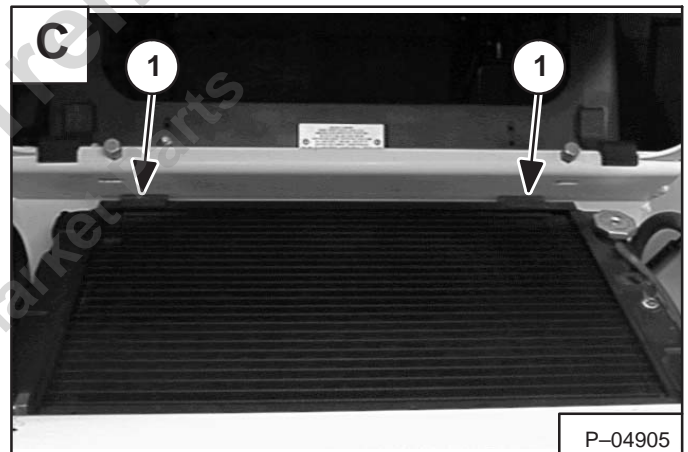

FAN DRIVE TENSION PULLEY

Removal And Installation

Remove the fan drive belt.

Remove the idler pulley bolt (Item 1) [A].

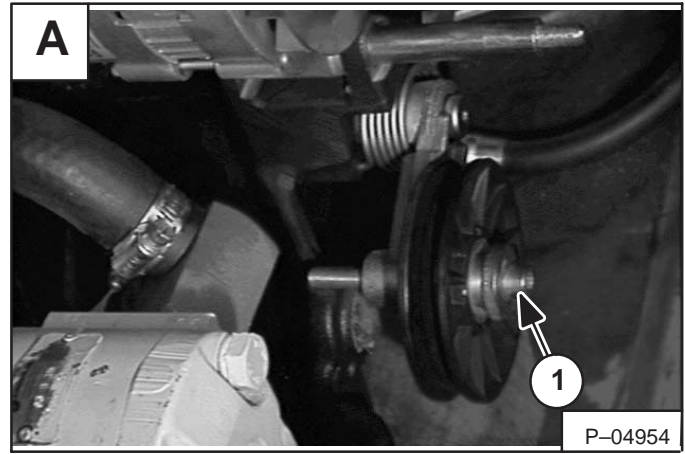

Remove the spacers, bolt and washers from the arm [B].

Installation: Put a small amount of grease around the outside edge on the grease rings (Item 1) [B] between ring and bearing.

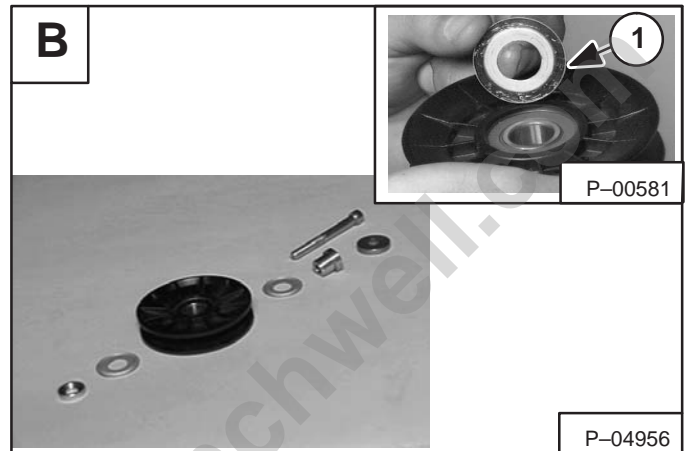

Remove the bolt (Item 1) [C], spring and arm.

Check all parts for damage or wear. Replace the parts as needed.

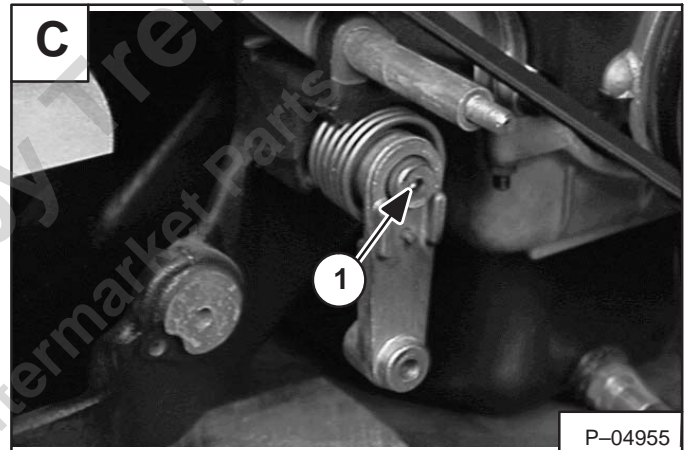

Installation: Grease the pivot bolt (Item 1) [D] thrust washer (Item 2) [D] and O-rings (Item 3) [D].

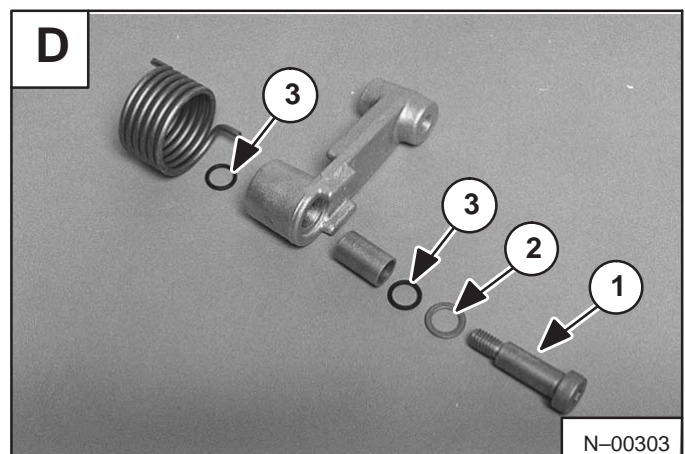

FAN GEARBOX/BLOWER HOUSING

Removal And Installation

**WARNING**

Never work on a machine with the lift arms up unless the lift arms are secured by an approved lift arm support device. Failure to use an approved lift arm support device can allow the lift arms or attachment to fall and cause injury or death.

W-2059-0598

Raise the operator cab. (See Page 1-1.)

Remove the mounting bolts (Item 1) [A] from the gas cylinder mounting bracket.

Installation: Tighten the mounting bolts to 80–90 in.-lbs. (9–10 Nm) torque.

Remove the hydraulic fluid reservoir. (See Page 2-1.)

Disconnect the wiring harness connectors (Item 1) [B].

Remove the harness clamp (Item 2) [B].

Disconnect the breather hose from the fan drive housing.

Move the electrical harness down for clearance at the blower housing.

Remove the clamp and belt shield (Item 1) [C] for the fan drive.

Remove the fan drive belt.

Installation: When checking the fan gearbox oil level, make sure the level does not go above the top of the shaft in the gearbox [C]. Use 90W gear lube oil if the level is low.

Use a putty knife to remove the sealant from the blower housing and loader frame [D].

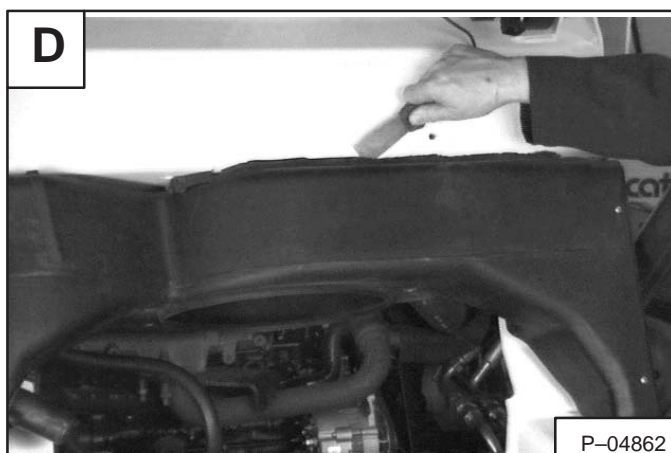
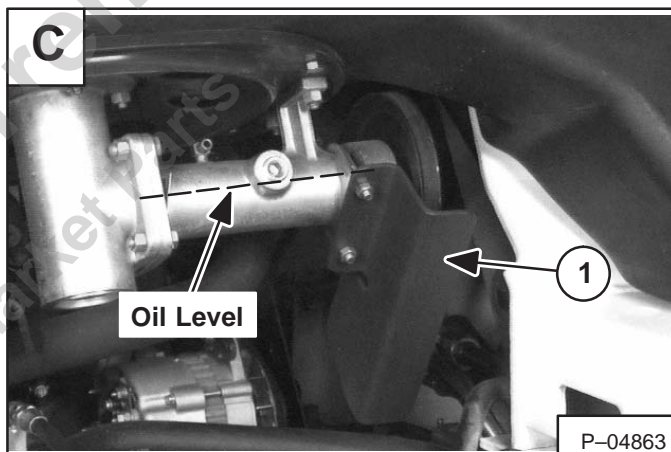
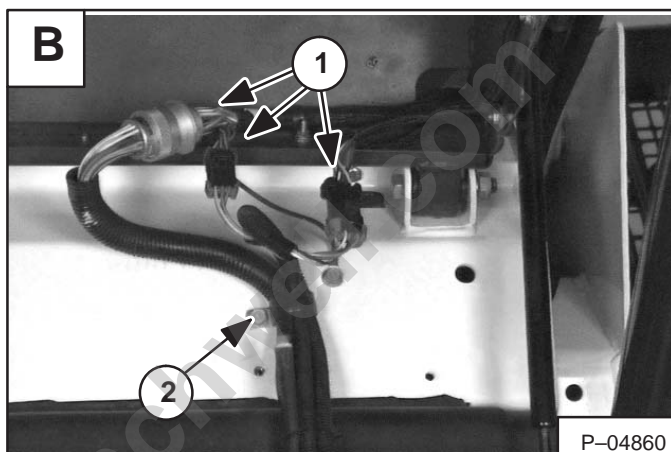
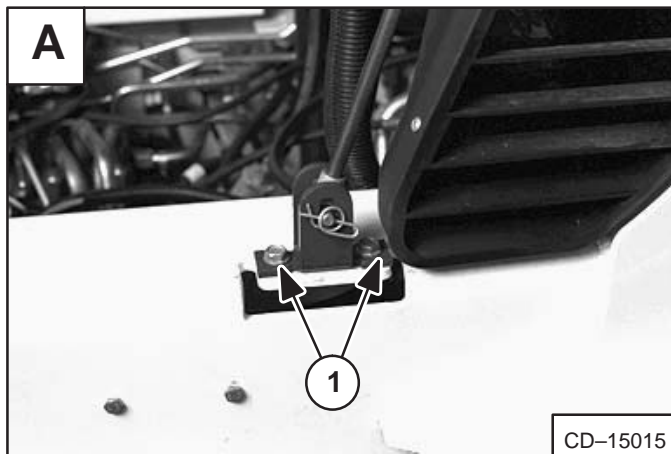

FAN GEARBOX/BLOWER HOUSING (Cont'd)**Removal And Installation (Cont'd)**

Installation: Use R.T.V. sealant to reseal the blower housing to the loader frame [A].

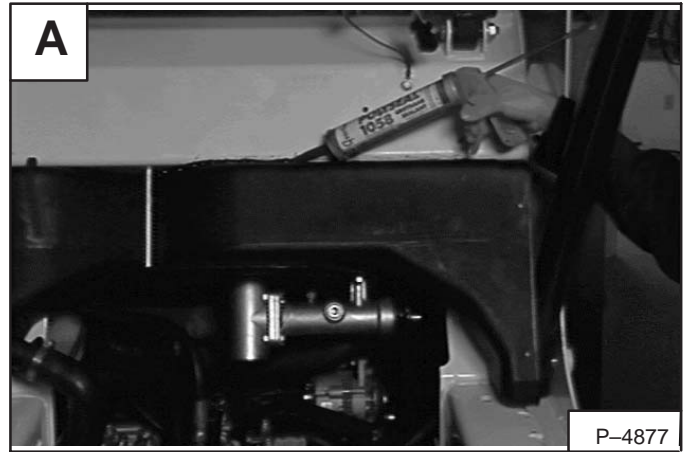

Remove the four mounting bolts (Item 1) [B] and spacer tubes (two outside housing and two inside housing).

NOTE: Remove the two rear mounting bolts first.

Installation: Use sealant on each end of the inside spacer tubes to prevent the tubes from falling out of the housing during installation.

Installation: Tighten the mounting bolts to 25–28 ft.-lbs. (34–38 Nm) torque.

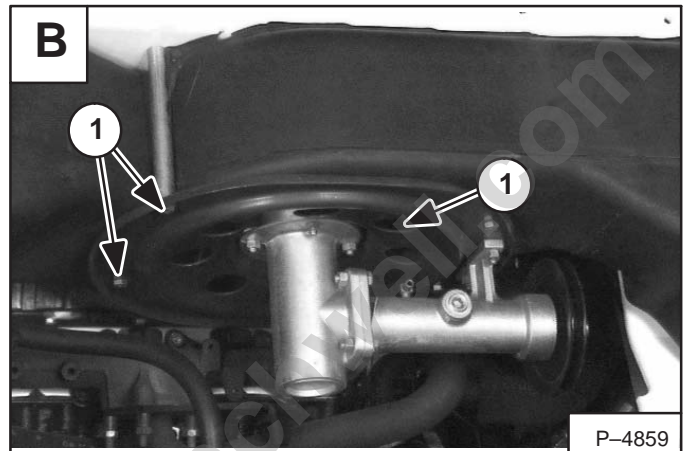

Slide the blower housing forward and remove the fan/fan gearbox assembly [C].

Remove the blower housing.

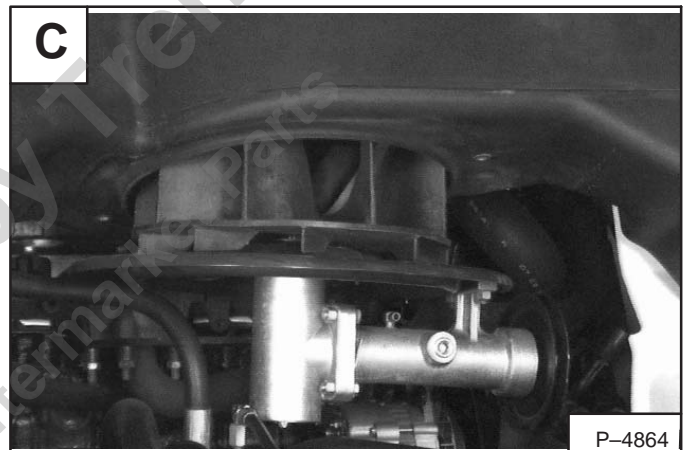

The blower housing must be moved away from the loader frame if the side grills have to be replaced.

To replace the side grill, remove the four mounting screws (Item 1) [D] from the blower housing.

Install the new grill and replace the screws.

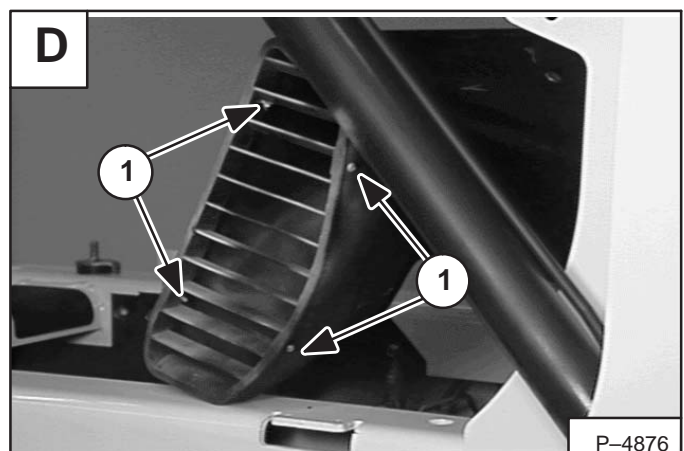

FAN GEARBOX/BLOWER HOUSING (Cont'd)**Removal And Installation (Cont'd)**

Remove the lock nut and spacer [A].

Installation: Tighten the nut to 45–55 ft.-lbs. (61–75 Nm) torque.

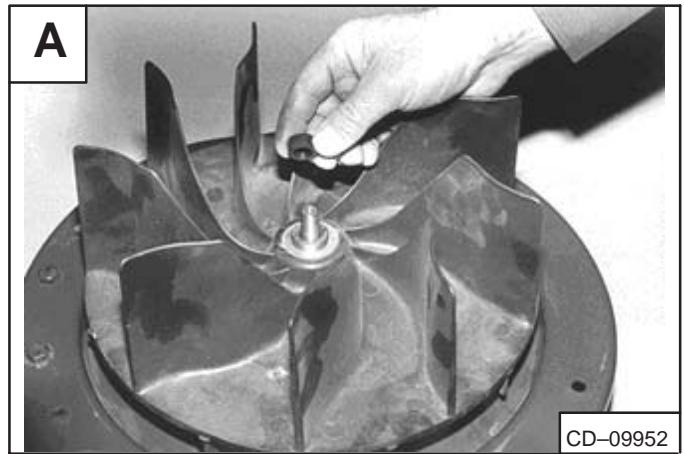

Use the following procedure to remove the fan from the shaft:

⚠ WARNING

AVOID INJURY OR DEATH

Wear safety goggles to prevent eye injury
when drilling or grinding.

W-2108-1186

Install the nut (Item 1) [B] on the tapered shaft to protect the shaft and threads.

Install the puller on the fan as shown [B].

As the center bolt (Item 2) [B] is tightened, periodically strike the bolt head to loosen the fan from the shaft.

Remove the fan from the tapered shaft [C].

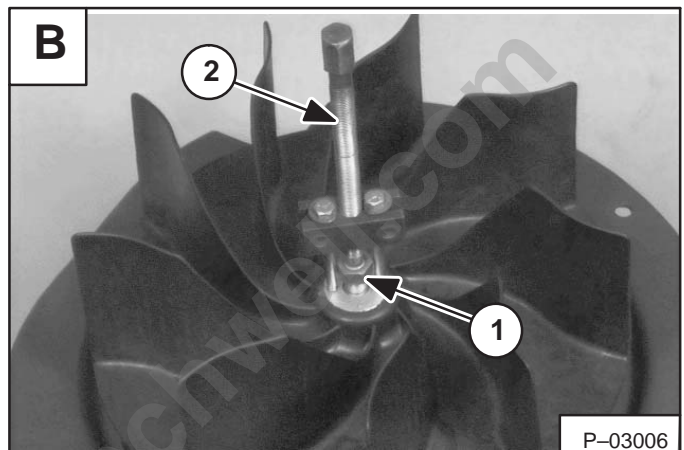

To remove the blower housing mounting plate, remove the six bolts (Item 1) [D].

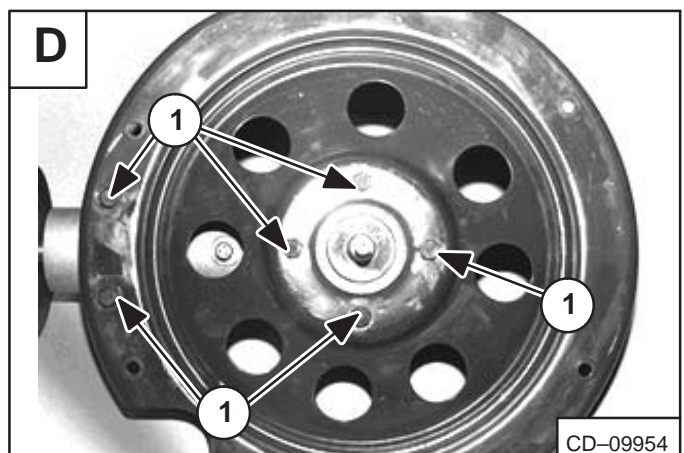

FAN GEARBOX/BLOWER HOUSING (Cont'd)**Removal And Installation (Cont'd)****Early S/N Loaders:**

Use the following procedure to remove the fan from the shaft:

Use a center punch to mark the aluminum bushing in the fan as shown in **[A]**.

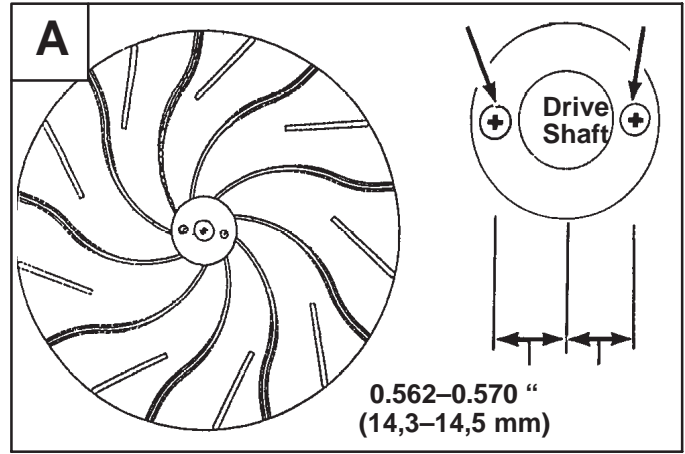

To insure straight drilling and tapping of the holes, a drill press is recommended.

Drill the two holes (Item 1) **[B]** 1.0 inch (25,4 mm) deep using a 13/64 inch drill bit.

Use a 1/4 inch NC bottom tap to cut maximum threads in the holes.

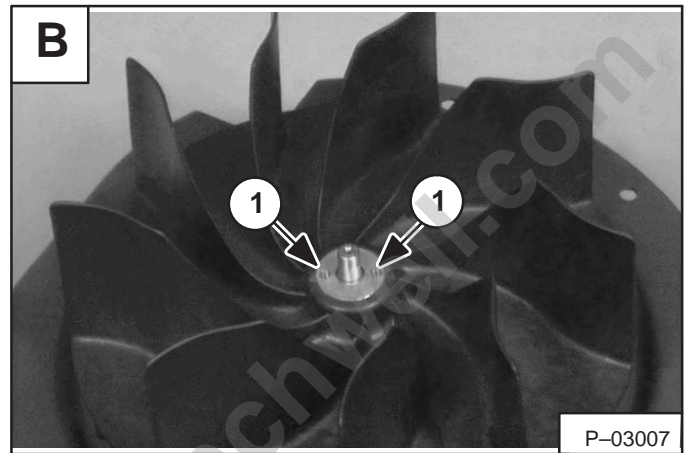

FAN GEARBOX

Parts Identification

- 1. Seal
- 2. Snap Ring (Small)
- 3. Shims (1.0 inch O.D.)
- 4. Bearing
- 5. Shaft (Long)
- 6. Shims (2.0 inch O.D.)
- 7. Long Key
- 8. Shaft (Short)
- 9. Short Key
- 10. Long Housing
- 11. Nut
- 12. Gear
- 13. Washer
- 14. Screw
- 15. Square Shim
- *16. Short Housing
- 17. Bolt
- 18. Snap Ring (Large)
- 19. Cap
- 20. Long Housing Assy.
- 21. Short Housing Assy.
- 22. Fill Plug

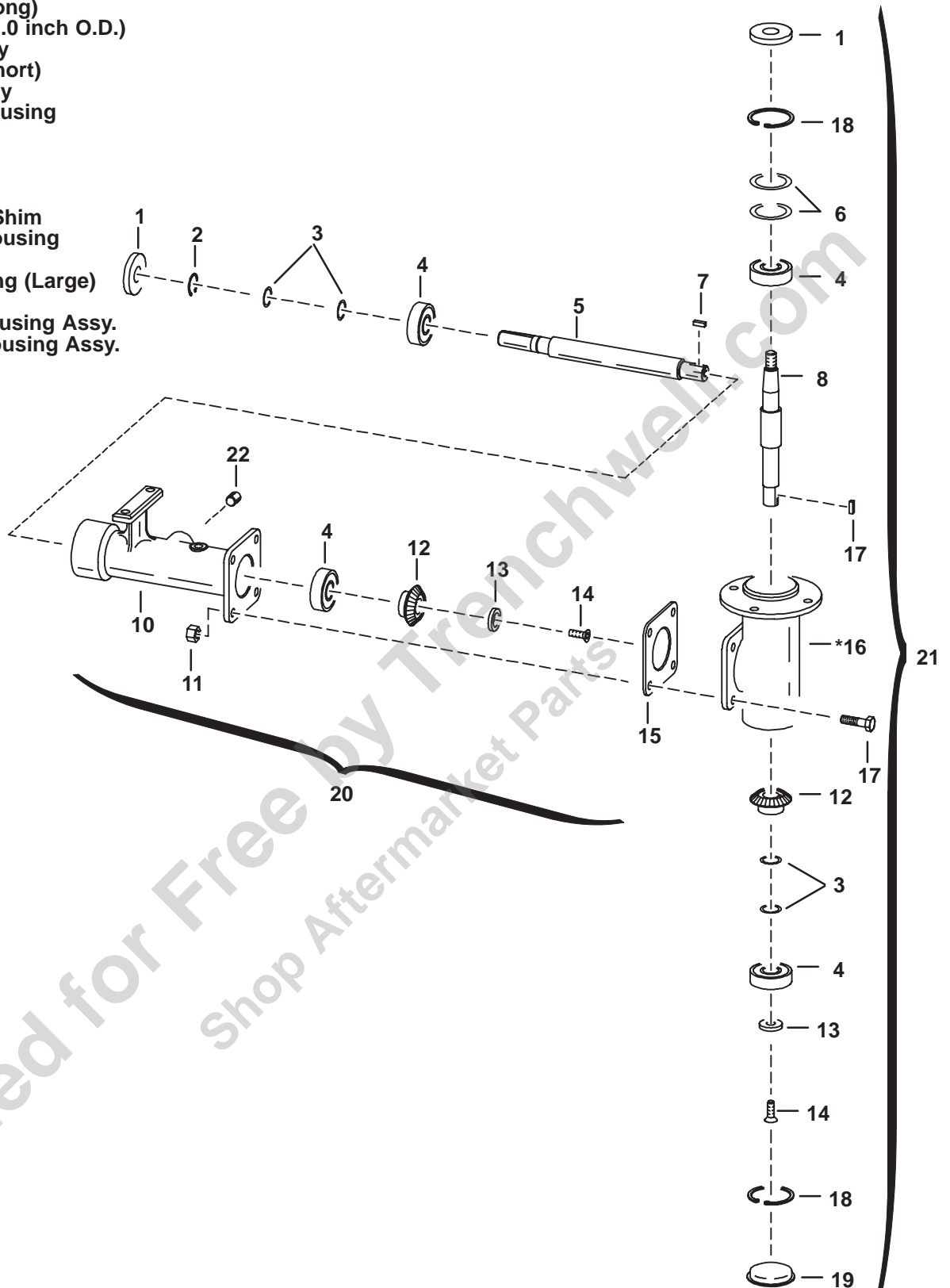

* Individual Part not available

TS-01002

FAN GEARBOX (Cont'd)**Disassembly**

NOTE: When repairing the gearbox order the following as needed:

1. Complete Assembly
2. Long Housing Assembly
3. Long Housing
4. Short Housing Assembly (See Note Below)
5. Internal Parts

NOTE: The short housing is only available as an assembly. See the *Parts Identification* Page 7–17 for reference. (Order parts from Melroe Parts Sales.)

NOTE: Be sure to count the number and thickness of shims during disassembly. Install the shims in the original location during assembly.

Remove the fan and blower housing mounting plate. (See Page 7–15.)

Long Housing

Loosen the set screws (Item 1) [A] and remove the pulley (Item 2) [A].

Remove the long key (Item 3) [A].

Remove the four mounting bolts and the part number tag [B].

Remove the oil from the gearbox.



Drill an 1/8 inch (13 mm) hole in the seal. Use a slide hammer tool to remove the seal [C].

Remove the small snap ring [D].

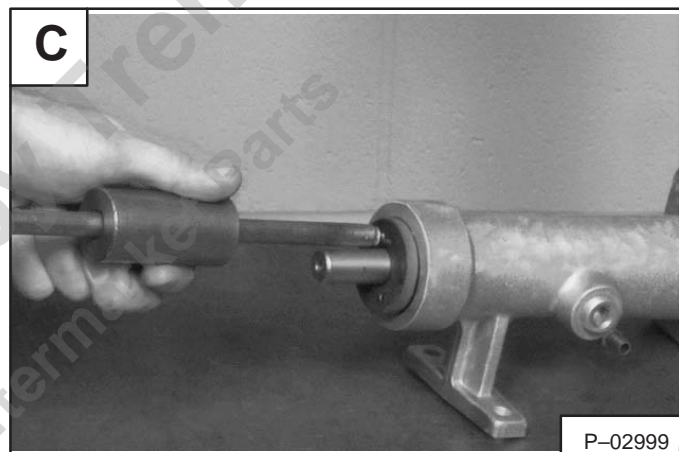
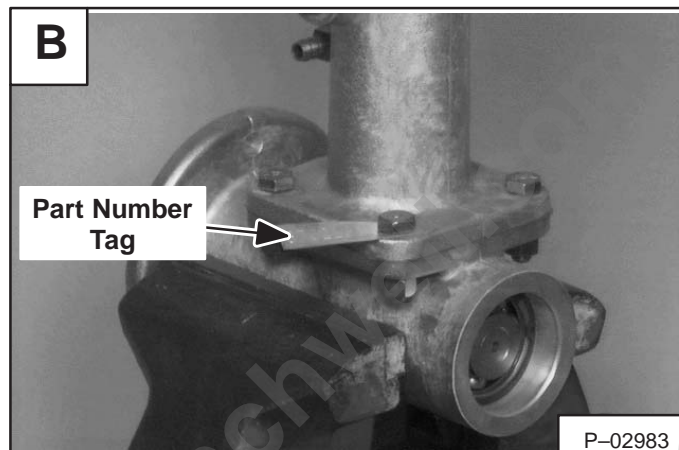
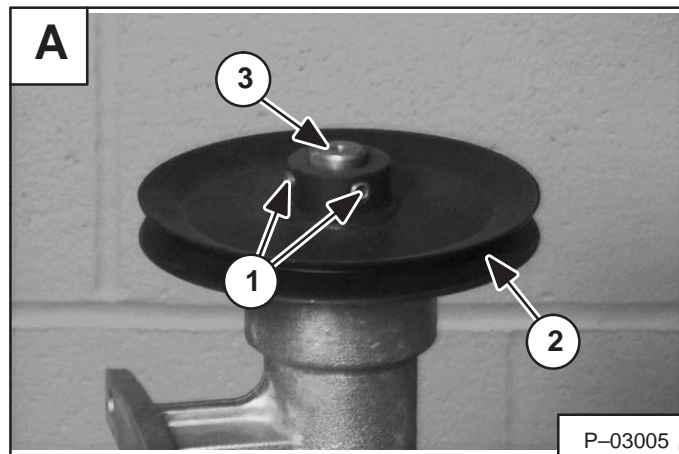

FAN GEARBOX (Cont'd)

Disassembly (Cont'd)

Remove the small shims [A].

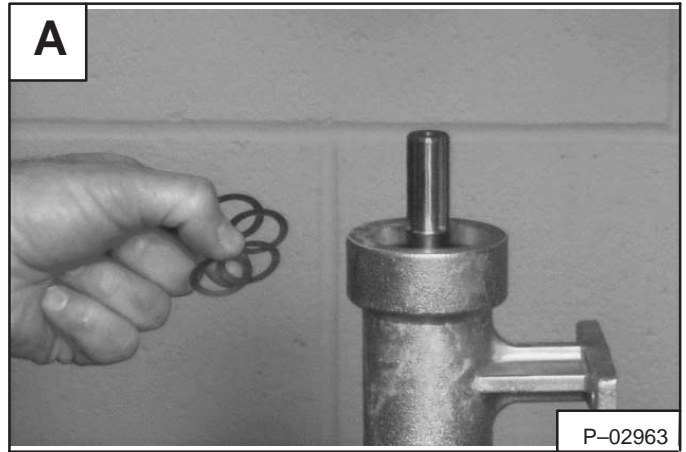

Remove the screw and washer from the shaft [B].

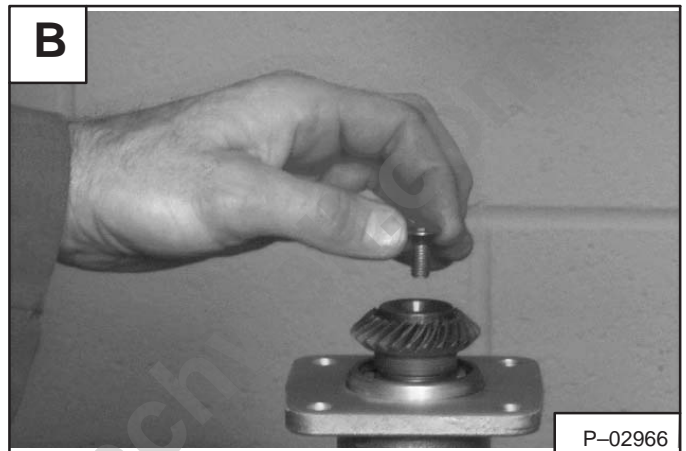

Support the lower flange and press the shaft from the bearing [C].

NOTE: The gear and the other bearing (pulley end) will be removed with the shaft.

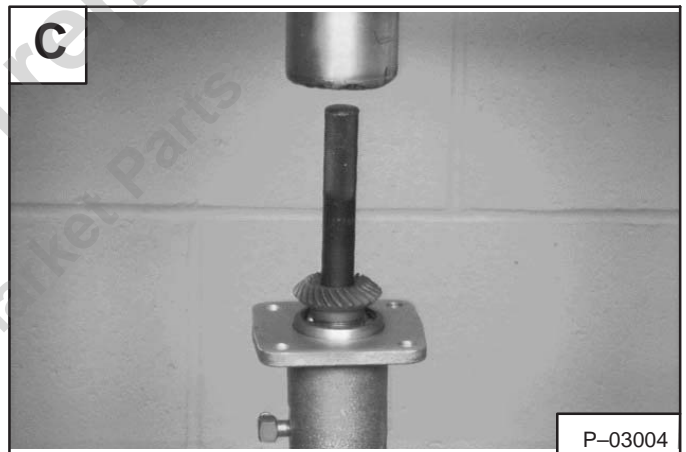

Support the bearing and press the shaft from the bearing [D].

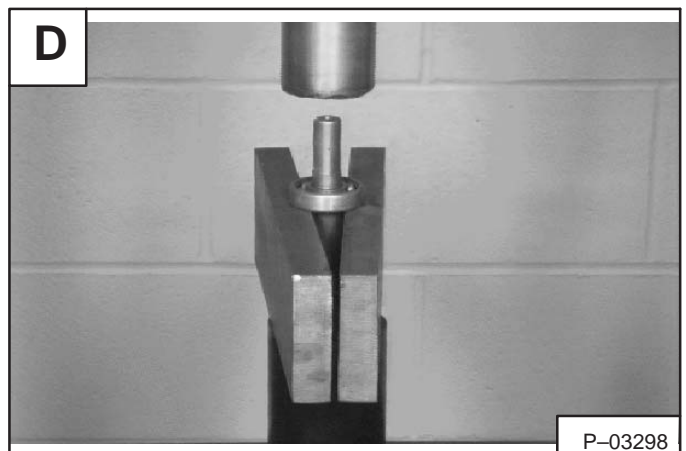

FAN GEARBOX (Cont'd)**Disassembly (Cont'd)***Short Housing*

Remove the end cap [A].

Use care not to damage the housing.



WARNING

AVOID INJURY OR DEATH

Wear safety goggles to prevent eye injury when drilling or grinding.

W-2108-1186

Drill an 1/8 inch (3 mm) hole in the seal. Use a slide hammer tool to remove the seal [B].

Remove the large snap ring from the flange end of the housing [C].

Remove the large shims from the housing [D].

NOTE: Use the same size and thickness of shims during assembly.

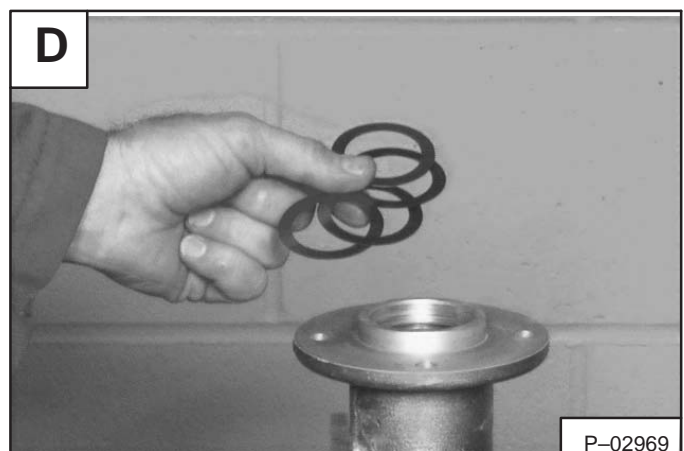
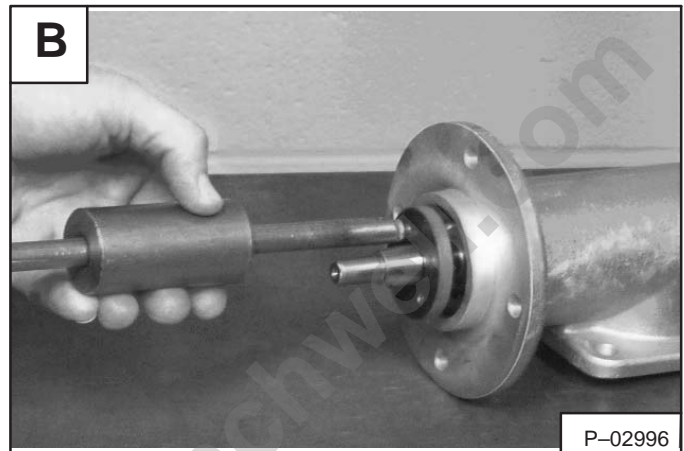

FAN GEARBOX (Cont'd)

Disassembly (Cont'd)

Remove the screw and washer (Item 1) [A] from the shaft.

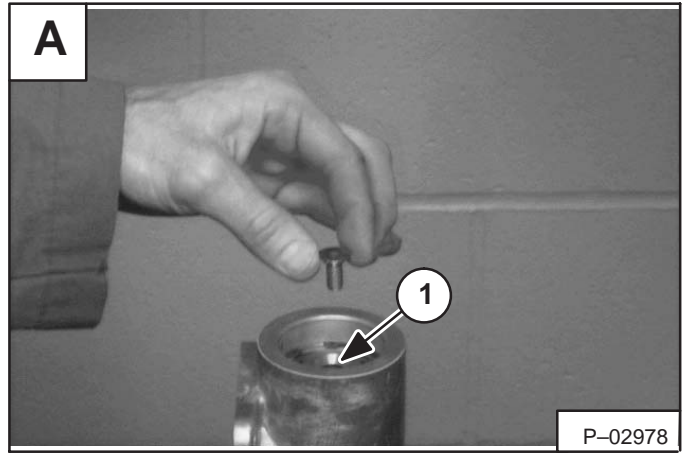

Remove the snap ring from the cap end of the housing [B].

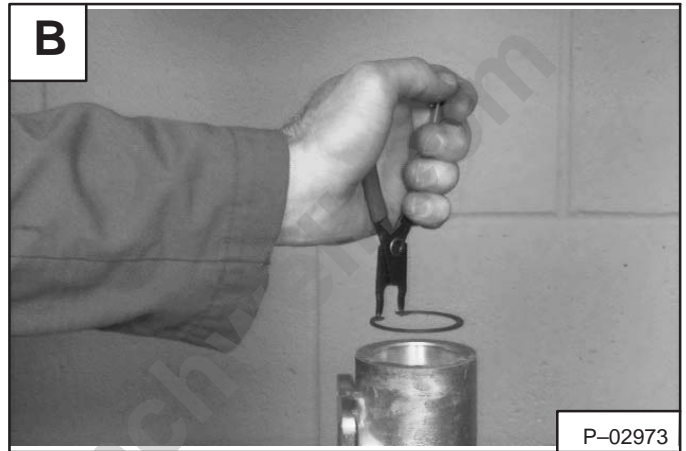

Press the shaft from the housing [C].

NOTE: Both bearings may come out of the housing with the shaft. If one bearing remains in the housing, use a non metal object to tap the bearing from the housing.

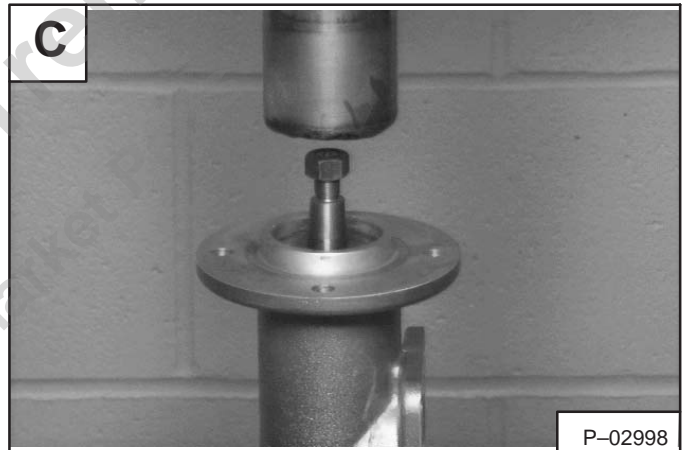

Press the bearing from the tapered end of the shaft [D].

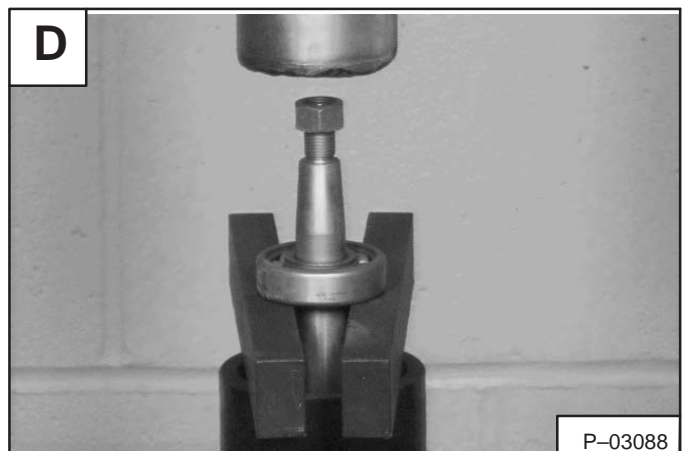

FAN GEARBOX (Cont'd)**Disassembly (Cont'd)**

Press the bearing, shims and gear from the shaft **[A]**.

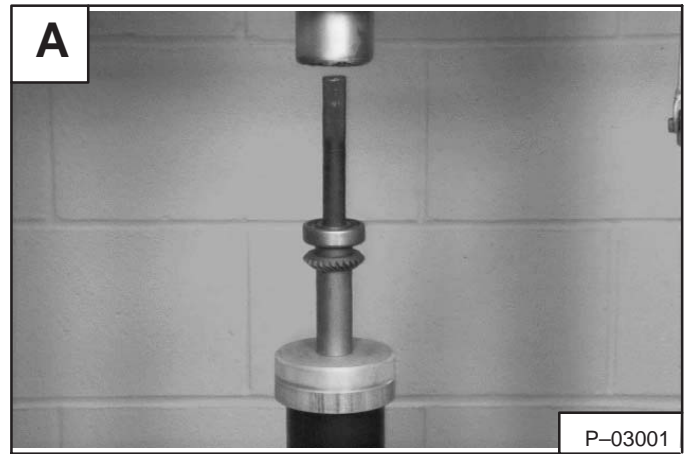

Remove the key (Item 1) **[B]** from the shaft.

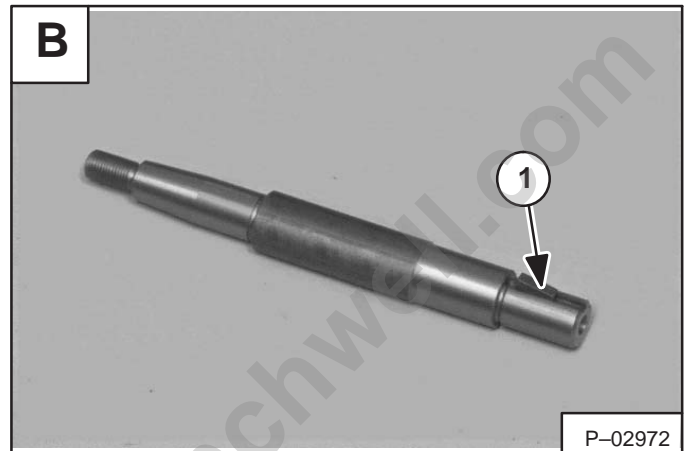
**Assembly***Long Housing*

Press a bearing on the short keyed end of the long shaft **[C]**.

Install the long housing on the shaft **[D]**.

Be sure the bearing is seated in the bore at the lower end of the housing.

Install a bearing on the long keyed end of the shaft **[C]**.

Support the lower bearing and press the other bearing in the housing until the bearings seat in the housing **[C]**.

Install on the bearing, the same number and size shims that were removed during disassembly **[D]**.

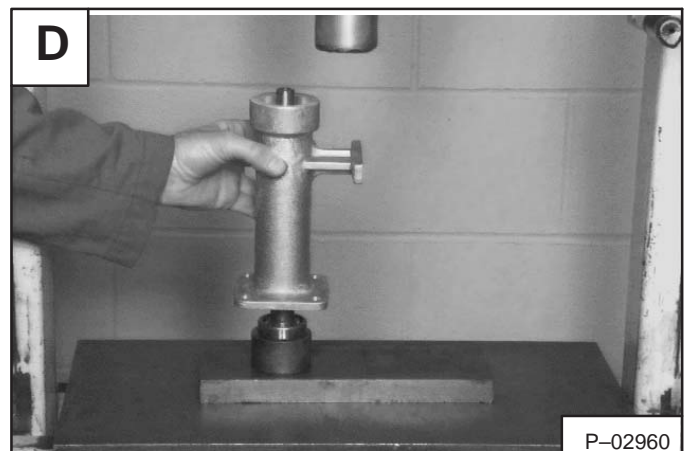

FAN GEARBOX (Cont'd)

Assembly (Cont'd)

Install the small snap ring in the groove above the shims [A].



Install the gear key in the flange end of the shaft [B].



Align the key and gear. While supporting the bearing on the other end, press the gear on the shaft until it seats against the bearing [C].

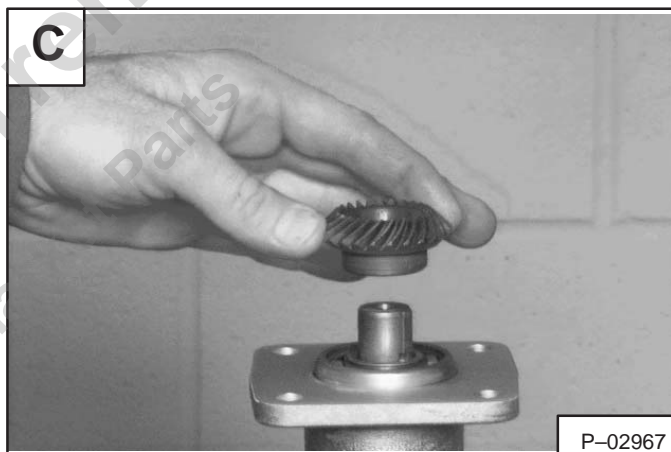

Install the washer [D].

Put LOCTITE #242 adhesive on the screw threads. Install and tighten the screw [D].



FAN GEARBOX (Cont'd)

Assembly (Cont'd)

Short Housing

Install a bearing in the flanged end of the housing **[A]**.



Install the large shims on the bearing (flanged end) **[B]**.



Install the large snap ring in the groove above the shims **[C]**.



Install the short key (Item 1) **[D]**.

Align and press the gear on the shaft (teeth toward the tapered end of the shaft) **[D]**.

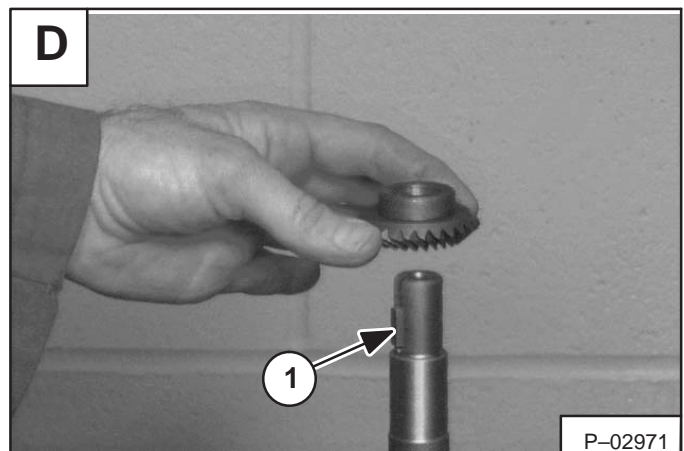

FAN GEARBOX (Cont'd)

Assembly (Cont'd)

After the gear is seated, drive the key down inside the gear key way [A].

NOTE: This will prevent damage to the shims when the bearing is installed later.

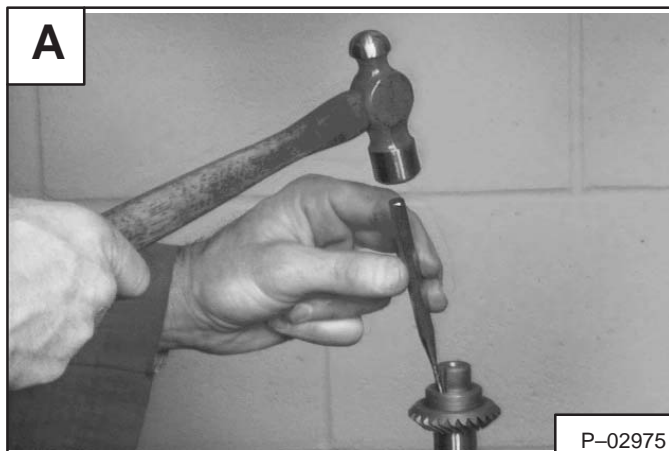

Install the shaft in the housing, tapered end in the bearing at the round flange end of the housing [B].



Install on the shaft, the same number and size shims that were removed during disassembly [C].



Install a bearing on the gear end of the shaft [D].



FAN GEARBOX (Cont'd)

Assembly (Cont'd)

Install the snap ring in the groove above the bearing [A].



Install the washer (Item 1) [B] on the shaft. Put liquid adhesive (LOCTITE #242) on the screw threads and install the screw [B].

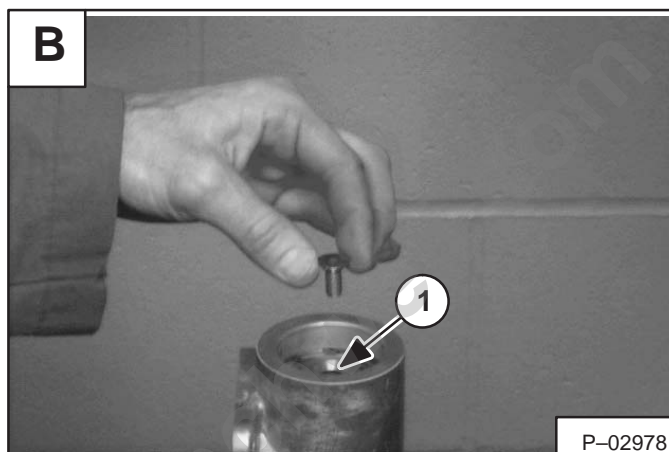

Provided for Free by Trend
Shop Aftermarket Parts

FAN GEARBOX (Cont'd)**Checking Backlash**

NOTE: For procedures requiring the use of LOCTITE adhesive, thoroughly clean and dry affected parts before the application of LOCTITE.

The backlash tolerance between the gears should be 0.005–0.008 inch (0,127–0,203 mm).

To check the gear backlash use the following procedure:

Put the short housing in a vise, square flange facing up as shown [A].

Install the same size and number of square shims (if present during disassembly) between the two housings [B].

Set the long housing on the short housing with a small amount of liquid adhesive (LOCTITE #242) between the mounting surfaces.

NOTE: If square shims are used, put a small amount of the liquid adhesive on both sides of all shims.

Install the four mounting bolts through the flange holes [C].

Install the part number tag [C].

Install and tighten the nut to 25–28 ft.-lbs. (34–38 Nm) torque.

Install the long key (Item 1) [D] and the pulley (Item 2) [D].

Install a bolt in the set screw hole to maintain a 1.0 inch (25,0 mm) distance from the shaft center to the bolt head (to be used with a dial indicator) [D].

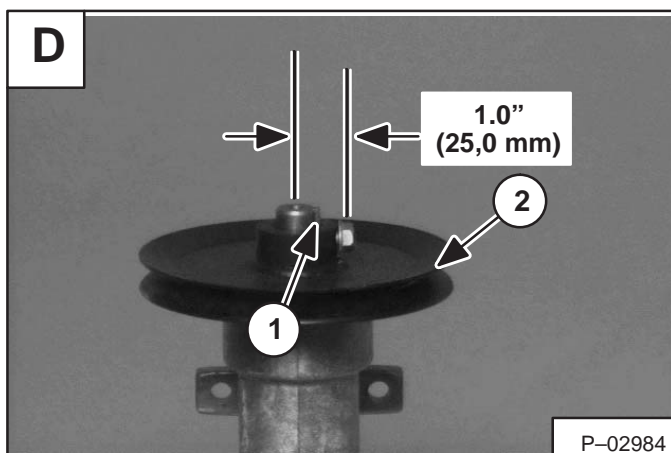
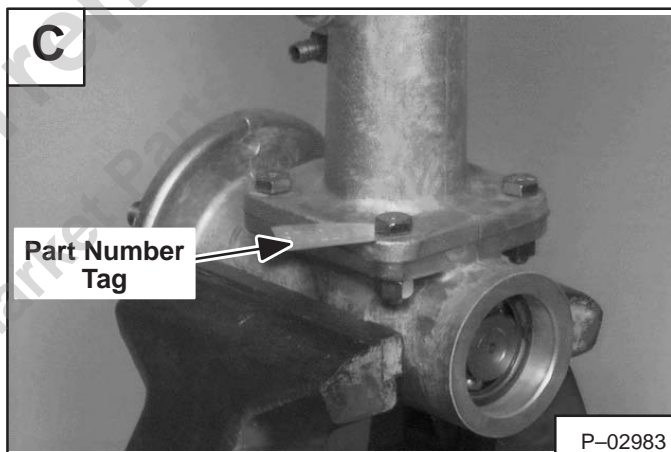

FAN GEARBOX (Cont'd)**Checking Backlash (Cont'd)**

Put the fan nut (Item 1) [A] on the shaft and tighten snugly.

Install a locking pliers on the fan nut and support the handle against the long housing [A].

Using a magnetic based dial indicator mounted on a bench vise, touch the dial stem on the bolt (Item 1) [B].

Hold the locking pliers against the long housing and rotate the pulley back and forth to read the dial gauge [B].

If the backlash is GREATER than 0.008 inch (0,203 mm), do the following:

1. Remove a square shim(s) (if present) between the two housings.
2. Remove a large shim(s) from the tapered end of the short shaft and add a small shim(s) of the same thickness between the bearing and the gear on the screw end of the shaft.

If the backlash is LESS than 0.005 inch (0,127 mm) do the following:

1. Add a square shim(s) between the two housings.
2. Remove a small shim(s) between the bearing and the gear on the screw end of the short shaft and add a large shim(s) of the same thickness between the snap ring and the bearing on the tapered end of the shaft.

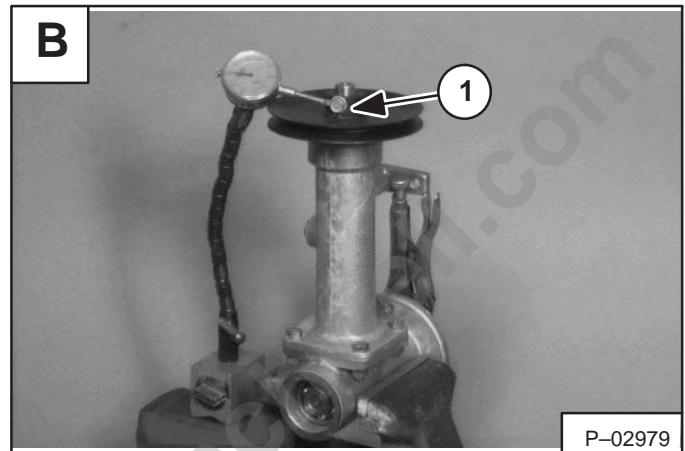
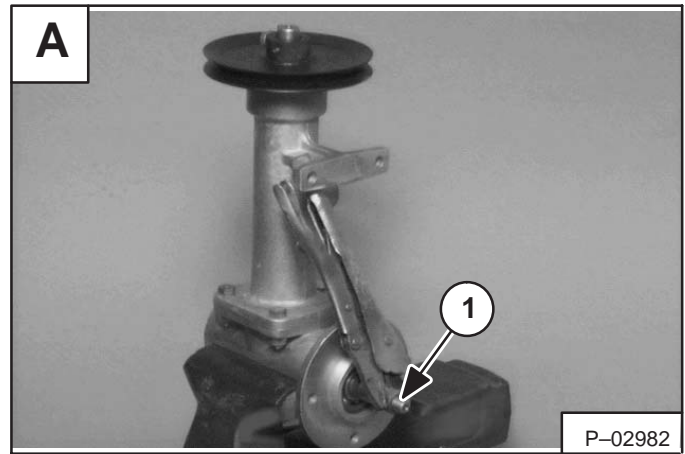

FAN GEARBOX (Cont'd)**Checking Backlash (Cont'd)**

When the backlash is correct, install the seals, cap and gear oil as follows:

Remove the bolts from the flanges and separate the two housings.

Put liquid adhesive (LOCTITE #242) on the outside diameter of the seal(s) **[A]**.

Install the seal(s) flush with the housing surface **[B]** & **[C]**.

Clean any oil from the flange surface.

Install the long housing on the short housing flange.

Install the four bolts and part number tag.

Install and tighten the nuts to 25–28 ft.-lbs. (34–38 Nm) torque.

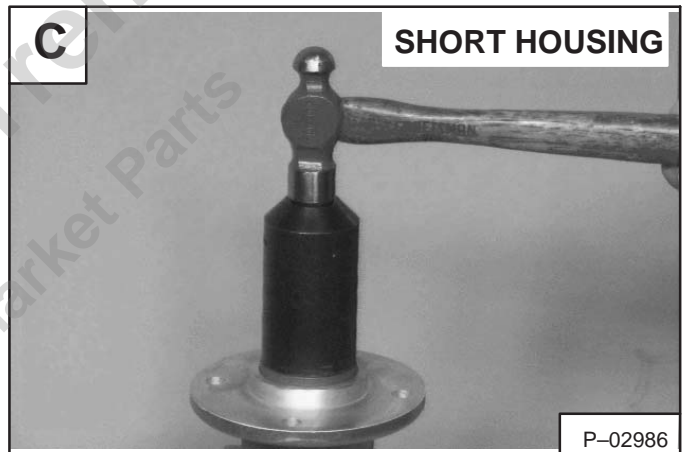
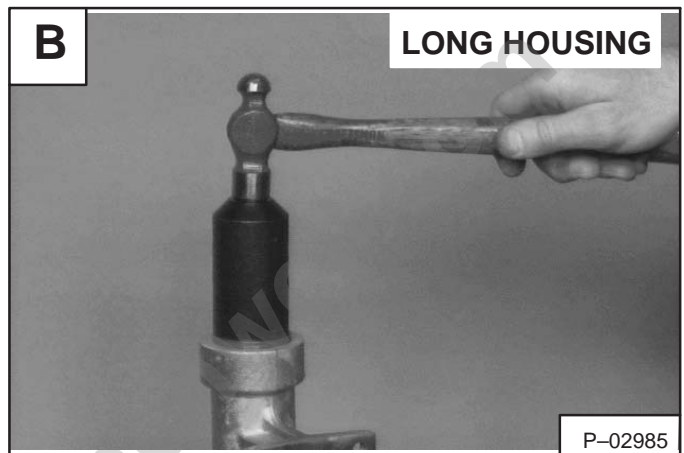
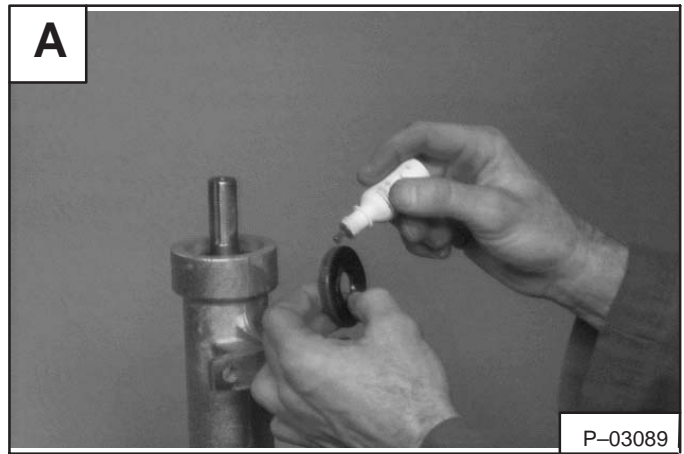

ENGINE**Removal And Installation**

WARNING

Never work on a machine with the lift arms up unless the lift arms are secured by an approved lift arm support device. Failure to use an approved lift arm support device can allow the lift arms or attachment to fall and cause injury or death.

W-2059-0598

DANGER
AVOID DEATH

- Disconnecting or loosening any hydraulic tubeline, hose, fitting, component or a part failure can cause lift arms to drop.
- Keep out of this area when lift arms are raised unless supported by an approved lift arm support. Replace if damaged.

53145

SW 98 6717343

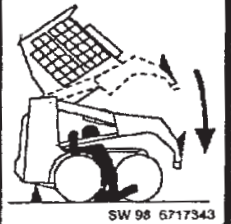

Raise the operator cab. (See Page 1-1.)

Disconnect the case drain hose (Item 1) [A] and drain the hydraulic fluid into a container.

After the fluid is removed from the reservoir, loosen both hose clamps and remove the hose (Item 2) [A] from the reservoir and hydrostatic pump.

Loosen both hose clamps and remove the fuel vent hose (Item 1) [B].

Loosen both hose clamps and remove the fuel fill hose (Item 2) [B].

Remove the fan drive belt (Item 1) [C].

Loosen the hose clamps and remove the hose (Item 1) [D] from the filter and the hydrostatic pump.

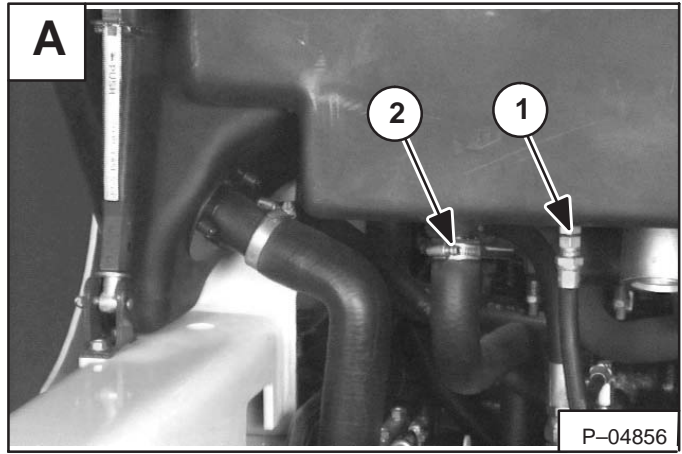

P-04856

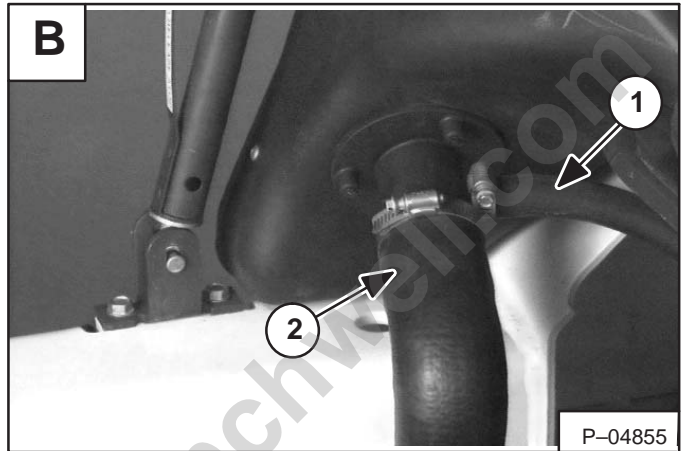

P-04855

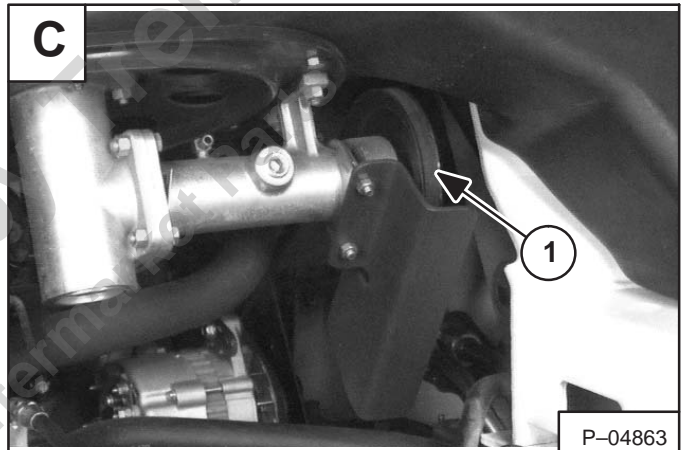

P-04863

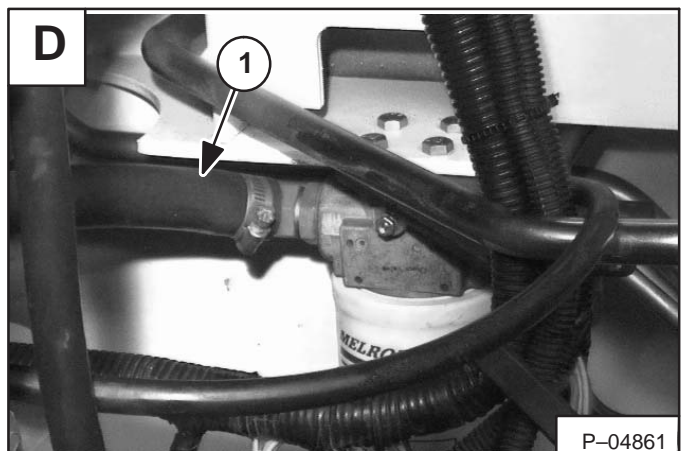

P-04861

ENGINE (Cont'd)**Removal And Installation (Cont'd)**

Disconnect the wires (Item 1 & 2) [A] at the filter.

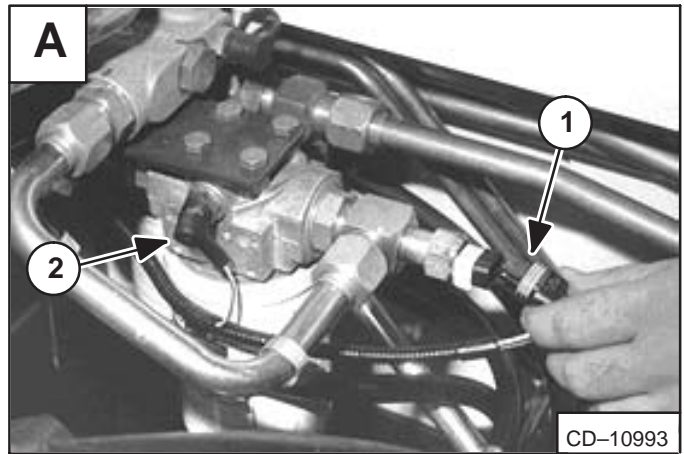

Disconnect the electrical harness connectors (Item 1) [B].

Disconnect the ground wire and harness clamp (Item 2) [B].

NOTE: The electrical harness will be removed with the engine.

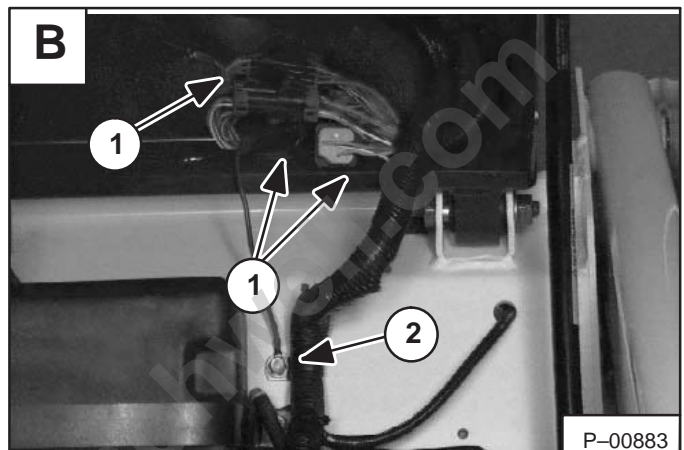

Disconnect the hose (Item 1) [C] from the oil cooler.

Disconnect the hose (Items 2 & 3) [C] from the hydrostatic pump.

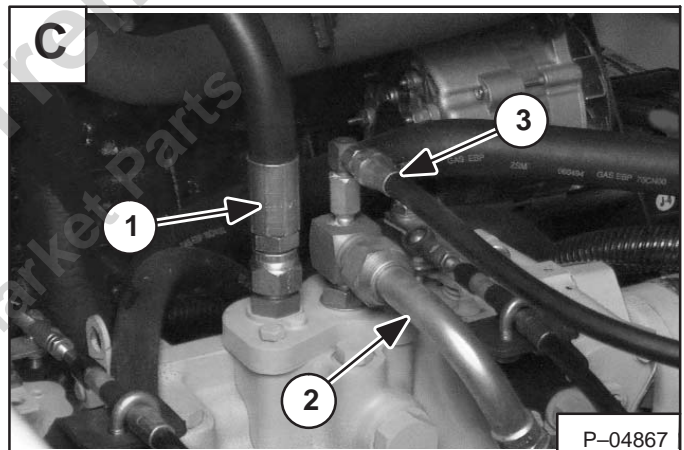

IMPORTANT

When making repairs on hydrostatic and hydraulic systems, clean the work area before disassembly and keep all parts clean. Always use caps and plugs on hoses, tubelines and ports to keep dirt out. Dirt can quickly damage the system.

I-2003-0284

ENGINE (Cont'd)**Removal And Installation (Cont'd)**

Disconnect the steering cables (Item 1) [A].

Installation: See Page 3-1 for transmission neutral adjustment.

Mark the high pressure hoses for correct installation.

Disconnect the four high pressure hoses (Item 2) [A] from the pump.

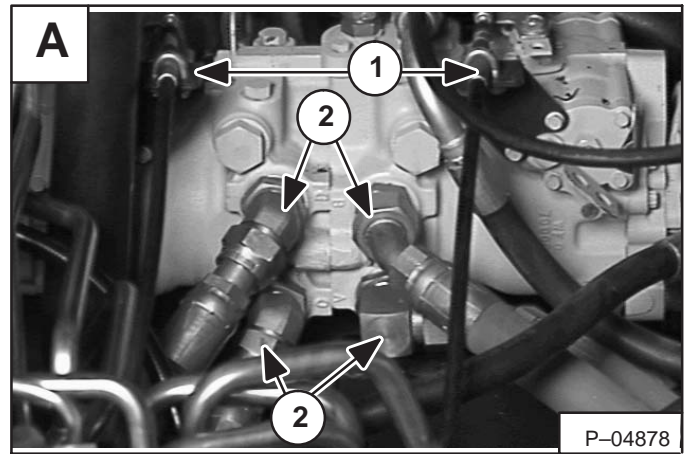

Disconnect the high pressure hose (Item 1) [B] from the hydraulic pump.

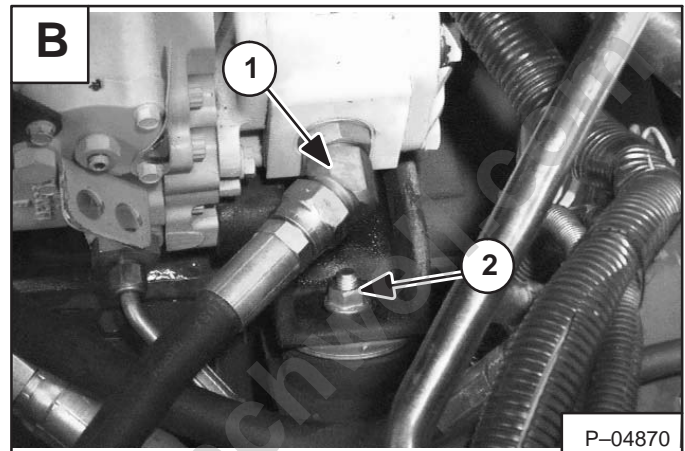

Disconnect the case drain filter hose (Item 1) [C] from the pump.

Remove the bolt and nut (Item 2) [B] at the left front engine mount.

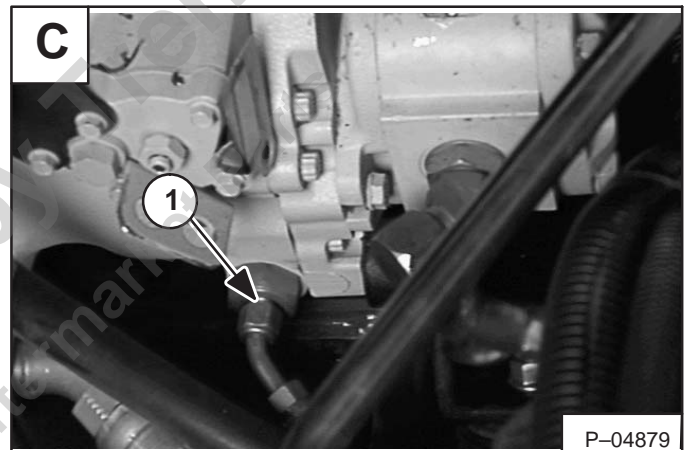

Remove the bolt (Item 1) [D] at the right front engine mount.

NOTE: The nut is held in the housing and will not turn (Inset) [D].

Installation: Tighten the mounting bolts and nuts to 90–100 ft.-lbs. (125–130 Nm) torque.

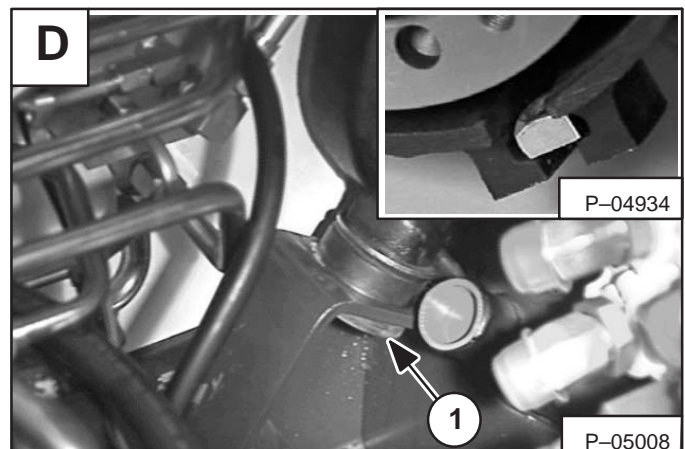

ENGINE (Cont'd)**Removal And Installation (Cont'd)**

Remove the battery. (See Page 6-1.)

Remove the air cleaner housing. (See Page 7-8.)

After the air cleaner hose is disconnected, remove the air horn (Item 1) **[A]** from the intake manifold.

Plug the intake manifold to prevent material from falling into manifold.

Remove the rear grill. (See Page 5-1.)

Remove the muffler. (See Page 7-7.)

Loosen the radiator cap.

Connect a hose to the engine block drain (Item 1) **[B]**.

Open the drain and drain coolant into a container.

Loosen the hose clamp and disconnect the radiator hose (Item 1) **[C]**.

Loosen the hose clamp and disconnect the radiator hose (Item 1) **[D]**.

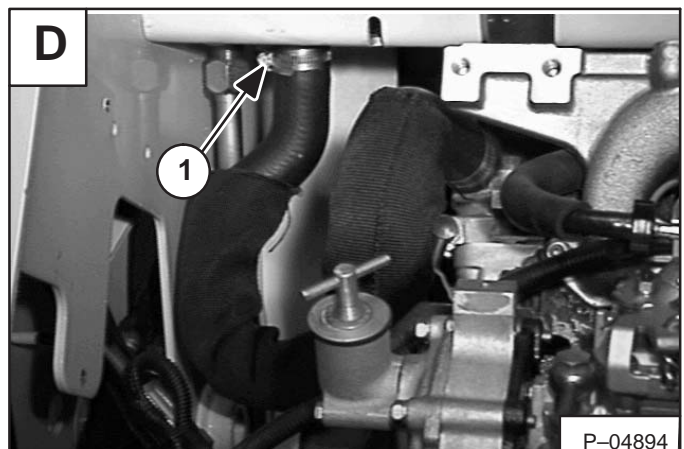
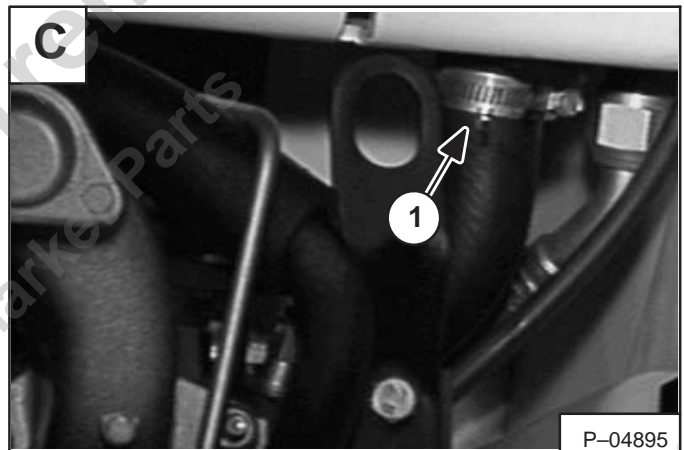
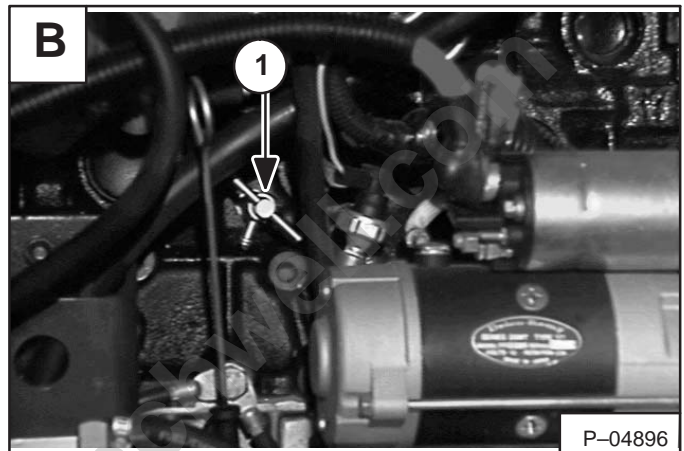
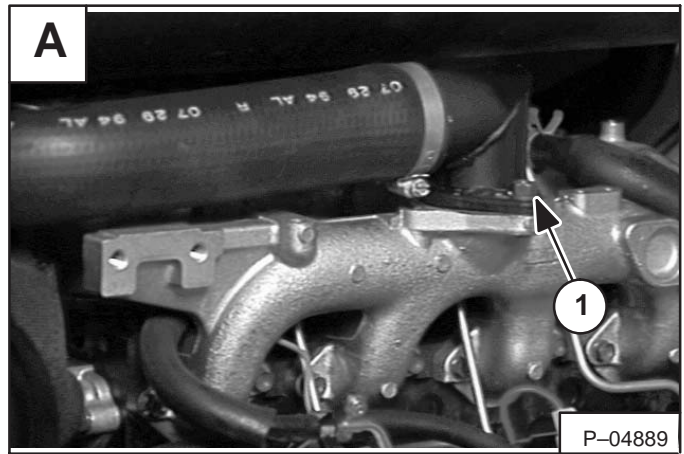

ENGINE (Cont'd)**Removal And Installation (Cont'd)**

Disconnect the electrical connector (Item 1) **[A]**.

Remove the coolant recovery tank and bracket (Page 7-9).

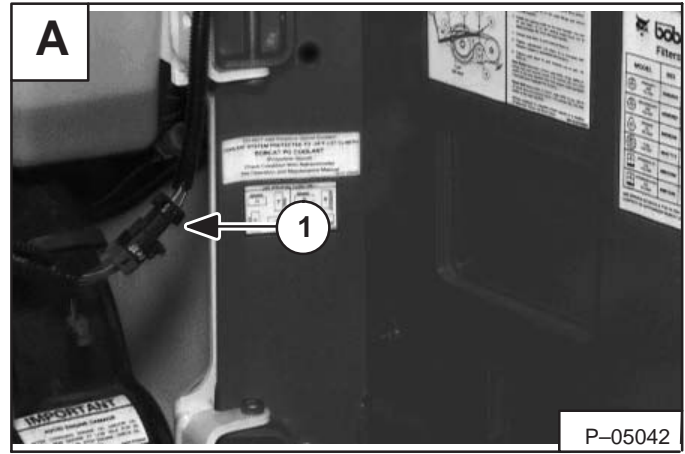

Disconnect the throttle linkage (Item 1) **[B]** from the bellcrank.

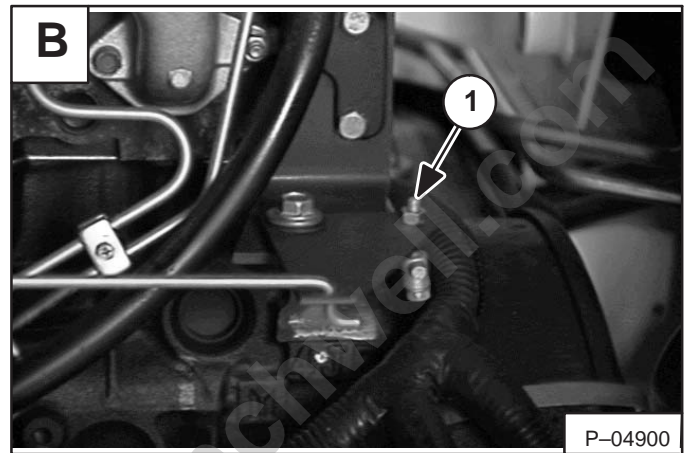

Disconnect the ground cable (Item 1) **[C]** from the loader frame.

Disconnect the fuel hose (Item 2) **[C]** from the fuel filter.

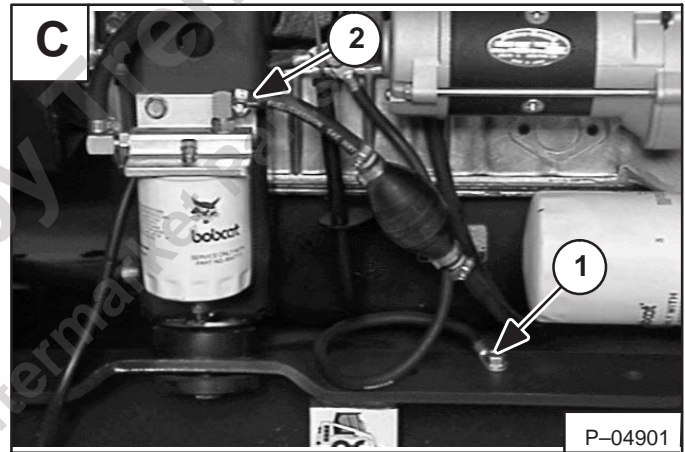

Disconnect the fuel return hose (Item 1) **[D]** from the injection pump.

Installation: Remove the air from the fuel system (Page 1-1).

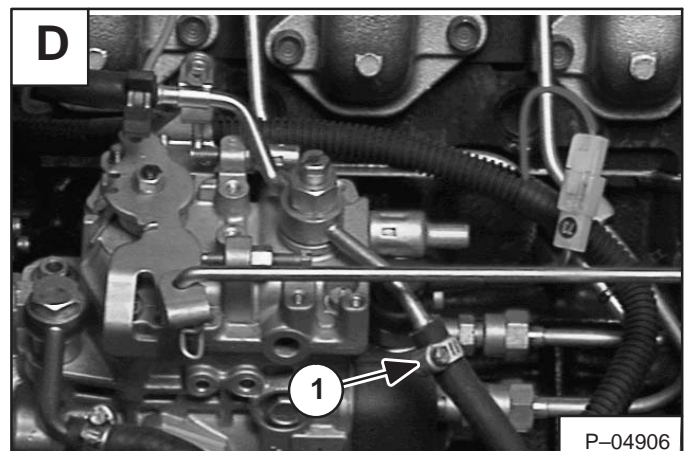

ENGINE (Cont'd)

Removal And Installation (Cont'd)

Remove the left rear engine mount bolt and nut [A].



Remove the right rear engine mount bolt (Item 1) [B].

Installation: Tighten the bolts and nuts to 65–70 ft.-lbs. (88–95 Nm) torque.



Use the dimensions from Figure [C] to make the engine Removal And Installation brackets.

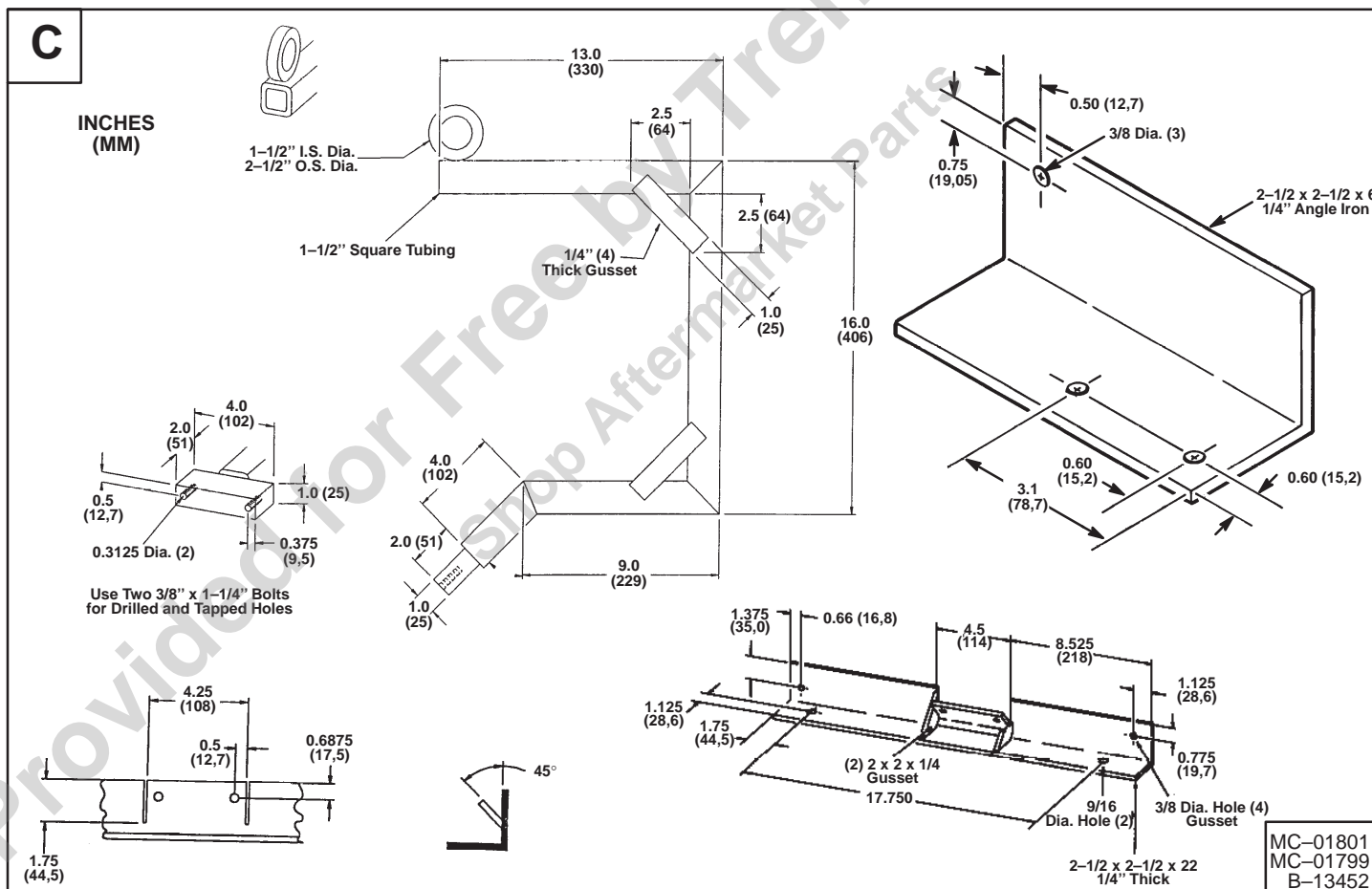

ENGINE (Cont'd)**Removal And Installation (Cont'd)**

The engine lift eye bracket (Item 1) **[A]** has been turned down for clearance at the exhaust pipe. Turn the lift eye bracket and install the bolt.

The valve cover (Item 2) **[A]** will have to be removed for clearance for the engine lift brackets.

Install the engine lift brackets on the engine as shown in Figure **[A]**.

Connect a chain hoist to the ring (Item 3) **[A]** on the lift bracket.

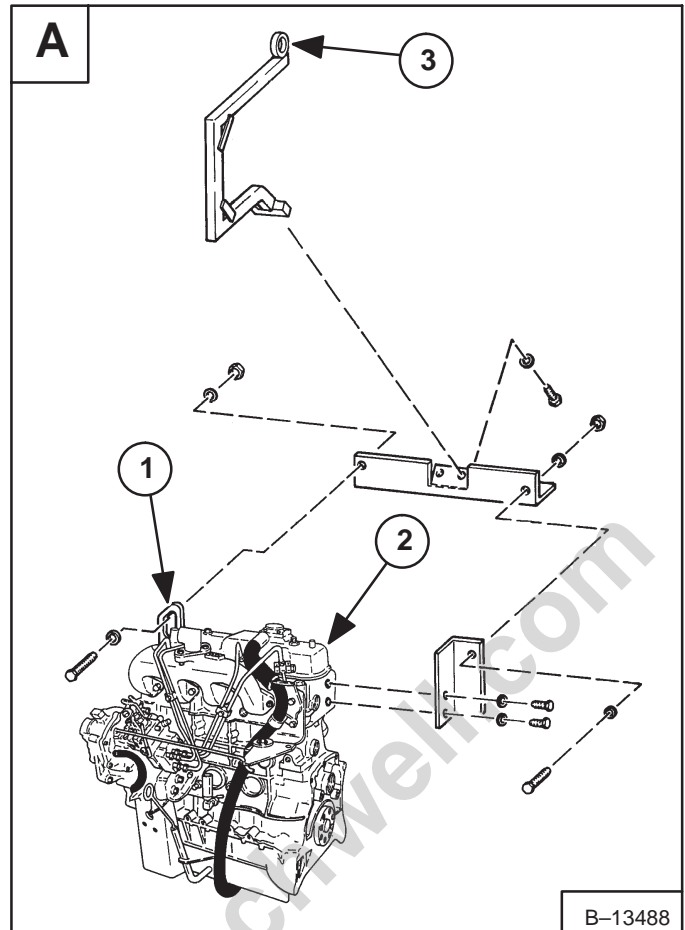

B-13488

Remove the engine/hydrostatic pump assembly from the loader **[B]**.

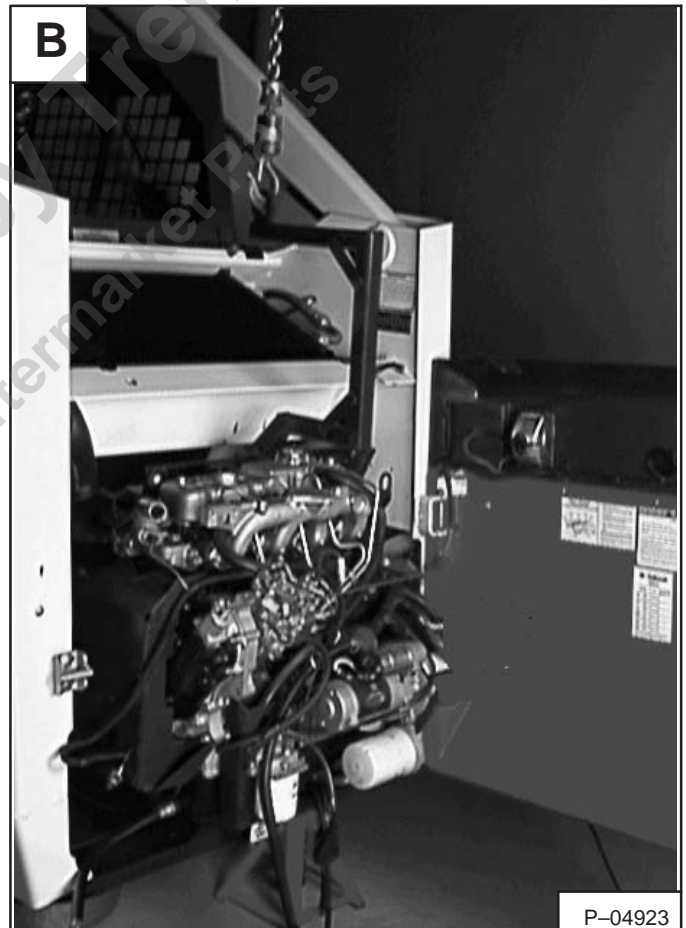

P-04923

FLYWHEEL

Removal And Installation

Remove the drive belt. (See Page 3-1.)

Remove the bolts (Item 1) [A] from the flywheel.

Installation: Put LOCTITE on the flywheel bolts. Tighten the bolts to 83–90 ft.-lbs. (113–122 Nm) torque.

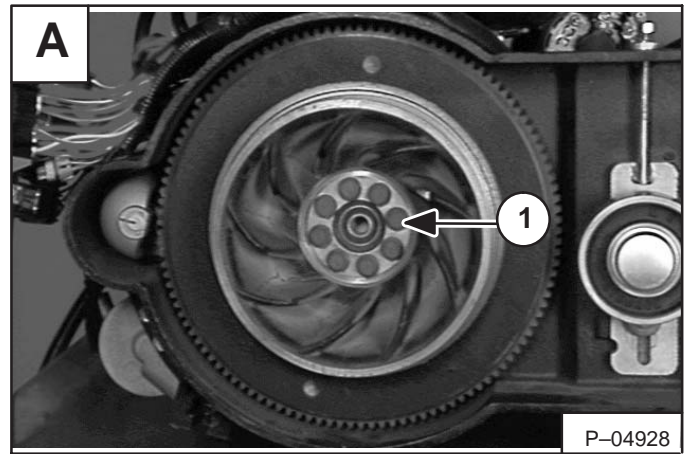

Remove the flywheel from the engine crankshaft [B].

Flywheel Ring Gear

The ring gear on the flywheel is an interference fit. Heat the ring gear enough to expand it and hit it with a hammer to remove it evenly.

Clean the outer surface of the flywheel to give it a smooth fit.

Clean the new ring gear and heat it to a temperature of 450–500°F (232–260°C).

Fit the ring gear over the flywheel. Make sure the gear is on the seat correctly.

NOTE: Early S/N Loader does not have cooling fins in flywheel.



BELT SHIELD

Removal And Installation

Remove the mounting bolt (Item 1) **[A]** from the thermostat housing.

Remove the mounting bolt (Item 2) **[A]** from the cylinder head.

Remove the mounting bolt (Item 3) **[A]**.

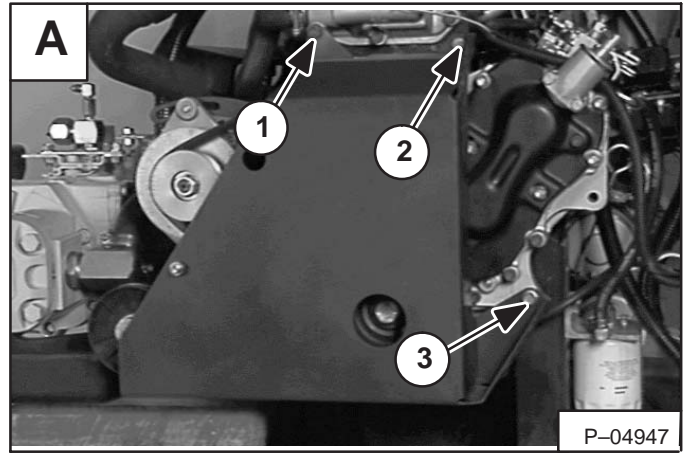

Remove the mounting bolt (Item 1) **[B]** from the alternator mounting bracket.

Remove the belt shield from the engine.

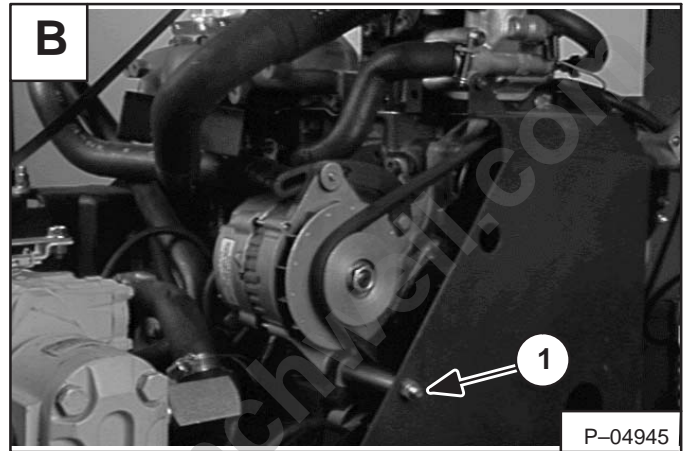

ENGINE MOUNTS

Removal And Installation

There is a kit available to replace the existing engine mounts in older model 853 loaders.

Use the following procedure to install new engine mounts:

Remove the existing mount from the engine. Refer to engine Removal And Installation for engine mount locations.

Replace all four engine mounts (2 front and 2 rear).

Use the parts shown to install the new engine mounts [A].

Item 1 – Square Nut – Used on left side engine mounts

Item 2 – Hex Nut – Used on right side engine mounts

Item 3 – Mount Washer

Item 4 – Engine Mount

Item 5 – Tube Spacer – Front 1.47 inch (37,3 mm)
Rear 1.57 inch (39,9 mm)

Item 6 – Snubbing Washer

Item 7 – Mounting Bolt

Install the new engine mount as shown in the cut away side view [B].

Tighten the mounting bolts to 90–100 ft.-lbs. (125–130 Nm) torque.

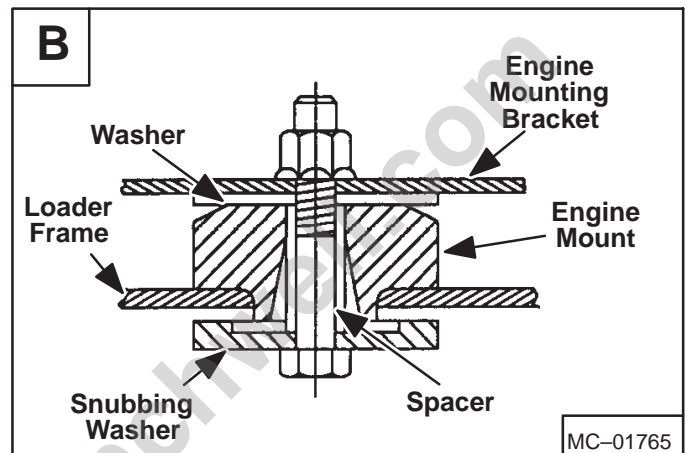
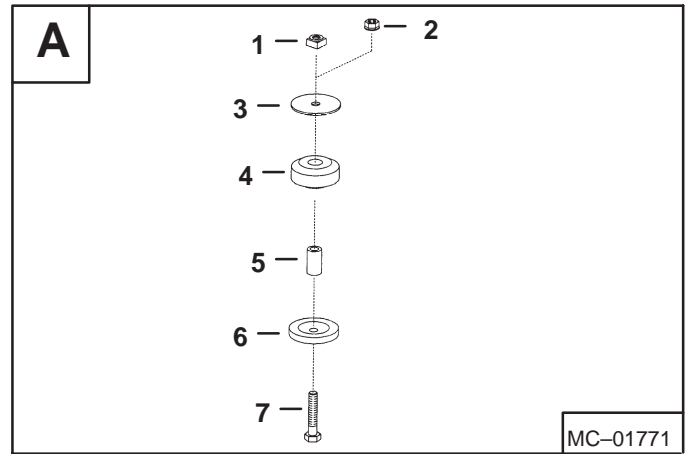

GLOW PLUGS

Removal And Installation

Disconnect the negative (-) cable from the battery.

Remove the electrical bar holddown nuts at the glow plugs **[A]**.

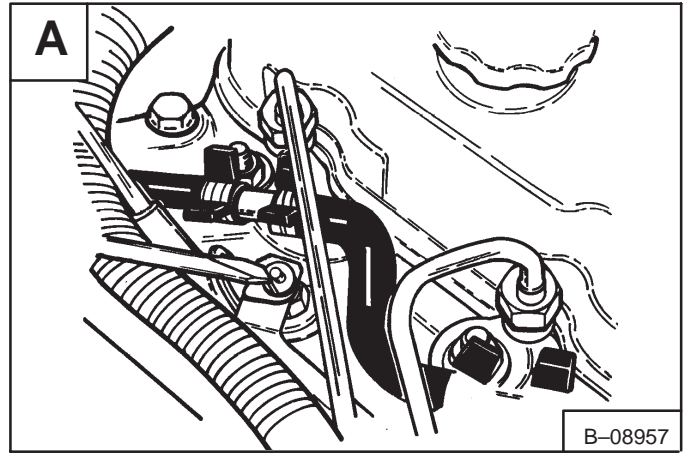

Remove the electrical connector bar **[B]**.

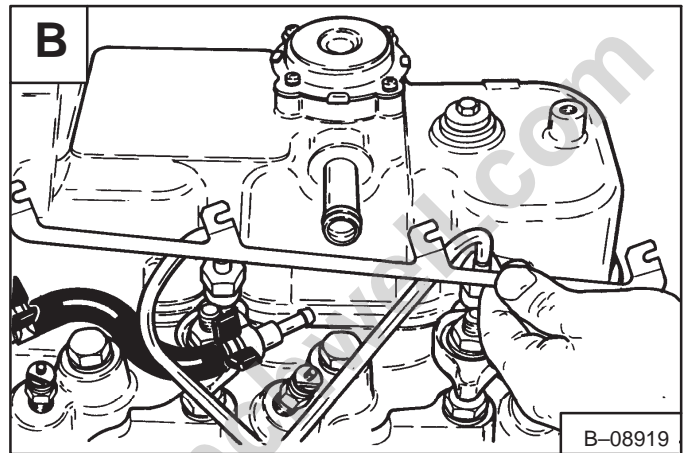

Remove the glow plug from the cylinder head **[C]**.

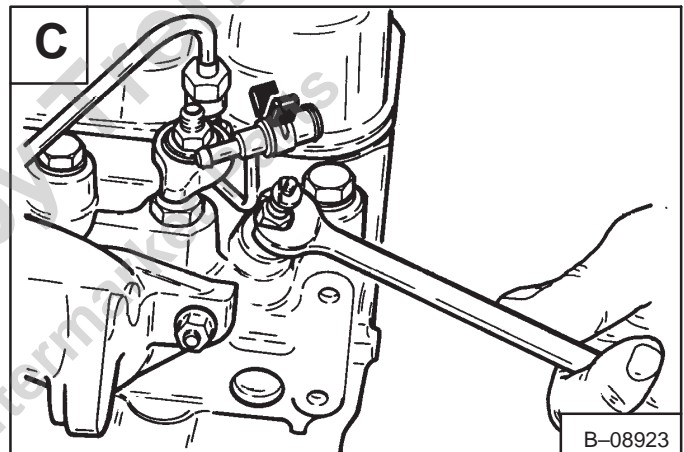

Checking The Glow Plugs

Connect the voltmeter to the terminal end of the glow plug. Touch the other lead from the voltmeter to the heating end of the glow plug **[D]**.

The reading must be approximately 1.5 ohms. If the resistance is zero ohms the glow plug has a short circuit. If the resistance is infinite, the coil of the glow plug is broken.

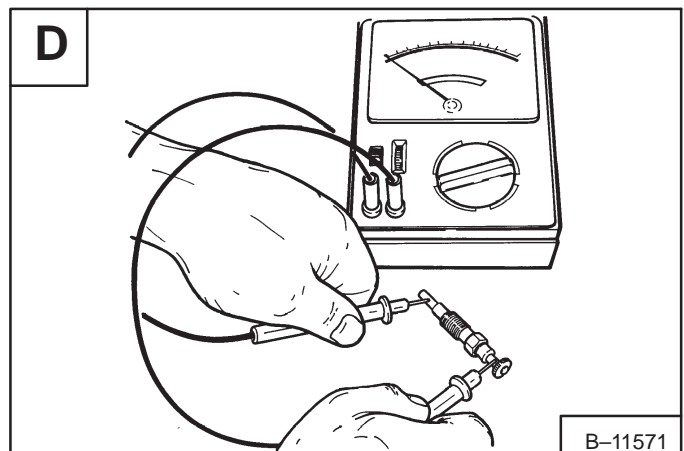

VALVE CLEARANCE

Adjustment

Make the valve clearance adjustment with engine stopped and cold.

The correct clearance is 0.016 inch (0,41 mm) with the engine cold [A].

Put the correct size feeler gauge between the rocker arm and the valve stem. Turn the adjustment bolt until the clearance is correct [B].

Use the following sequence to set the valve clearance:

Cylinder No.	Front		Rear	
	1	2	3	4
Valve arrangement	I E	I E	I E	I E
Piston in No. 1 cylinder is at TDC on compression stroke	•	•		•
Piston in No. 4 cylinder is at TDC on compression stroke			•	•

ENGINE COMPRESSION

Checking

The tools listed will be needed to do the following procedure:

OEM1074 – Engine Compression Kit
MEL1268 – Compression Gauge Test Adapter

The engine must be at operating temperature.

Remove the glow plugs [C]. (See Page 7–40.)

Install the correct compression adapter into the cylinder head.

Connect the compression gauge [D].

The engine must be turning at about 175 RPM.

The compression must be between 300–500 PSI (2069–3448 kPa) with no more than 50 PSI (345 kPa) difference between cylinders.

The engine has an open crankcase ventilation system.

The ventilation hose comes from the valve cover tube (Item 1) [D] and passes down the side of the engine block.

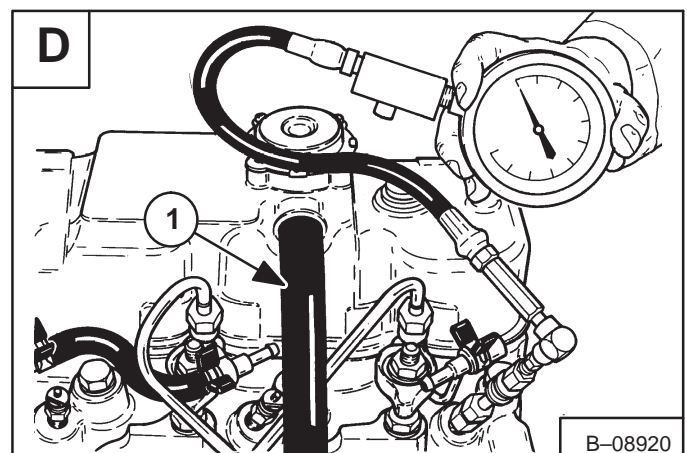
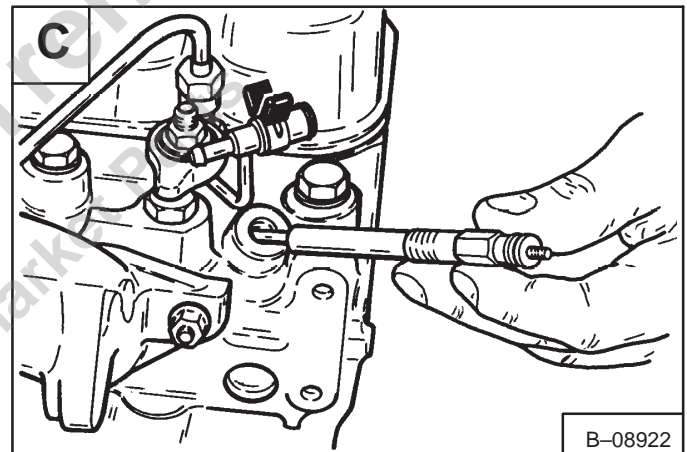
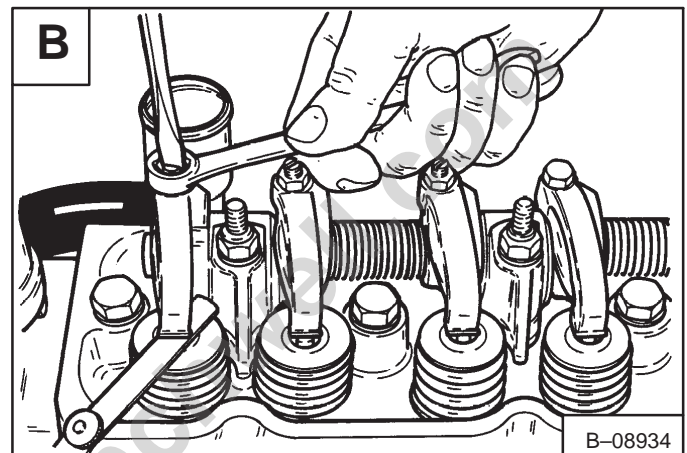
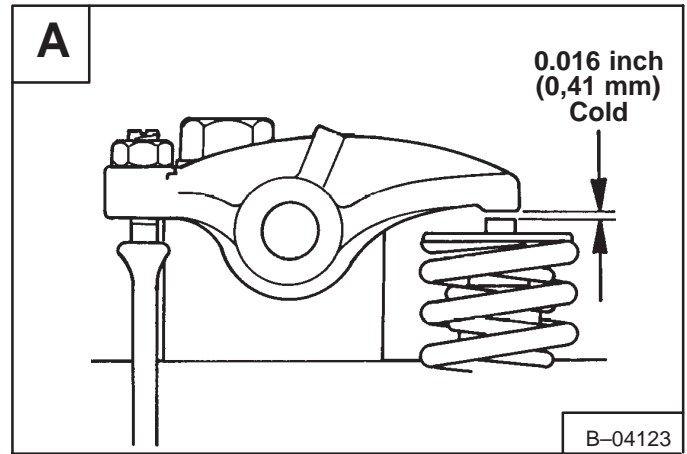

FUEL INJECTION PUMP

Description

The injection pump contains parts which have a very close tolerance and its operation has a direct effect on the performance of the engine.

IMPORTANT

Do not attempt to maintain or adjust unless you are trained and have the correct equipment.

I-2028-0289

Removal And Installation

Disconnect the throttle linkage.

Disconnect the shut-off wire [A].

Remove the valve cover.

Rotate the engine until No. 1 piston is at TDC. Both valves at No. 1 cylinder are not moving and have clearance [B].

The TDC mark (Item 1) [C] is located on the engine pulley v-belt groove.

There are two sets of timing marks on the engine pulley, one at 12 o'clock and the other at the 3 o'clock position. Use the timing marks located at the 3 o'clock position (Inset) [C].

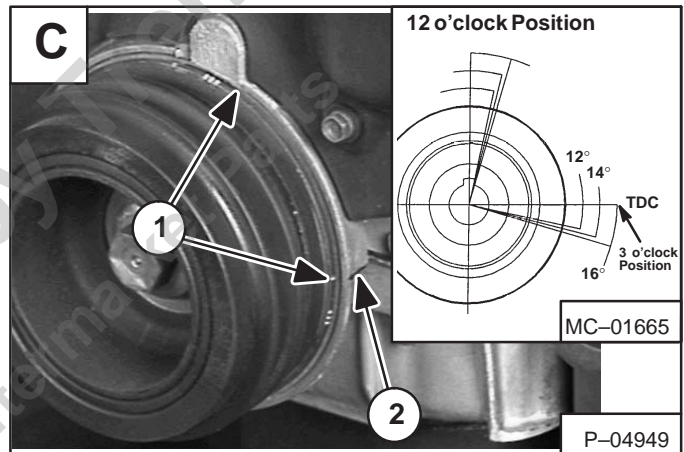
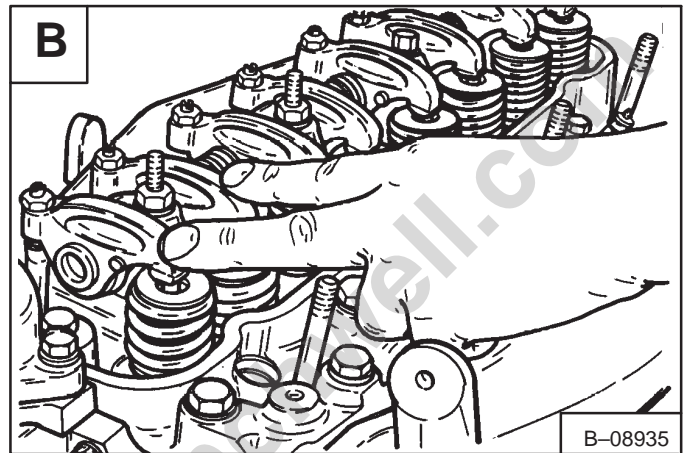
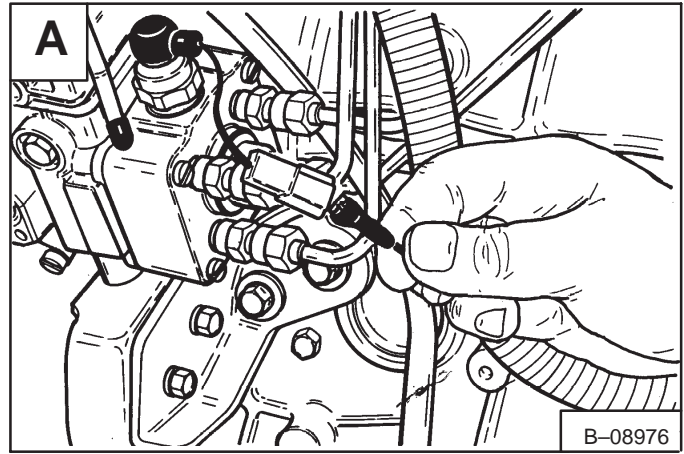

FUEL INJECTION PUMP (Cont'd)

Removal And Installation (Cont'd)

Use the parting line (off-set) (Item 2) [A] or (Item 1) [B] of the timing case cover to make alignment of the TDC mark.

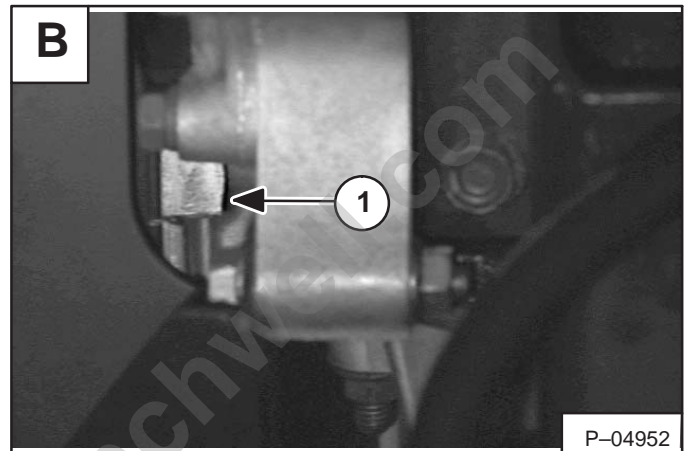
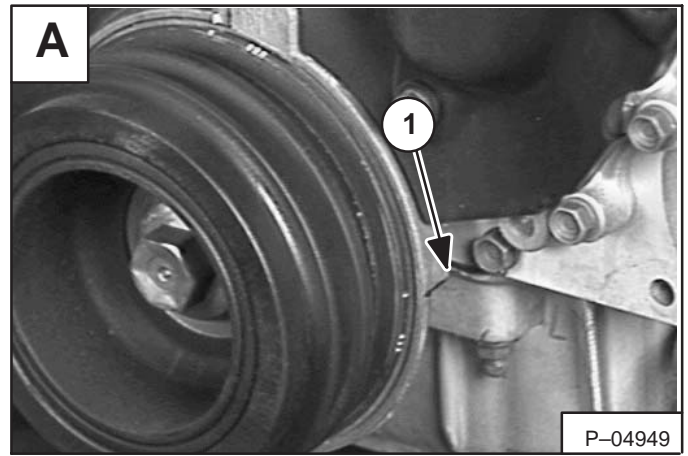

Early S/N Loader:

Disregard the pointer (Item 1) [C] in the belt shield for timing reference.

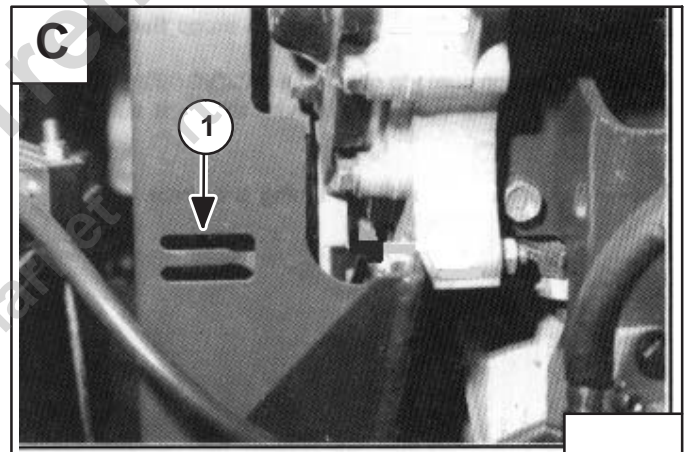

Align the mark on the injection pump gear with the pointer in the window [D].

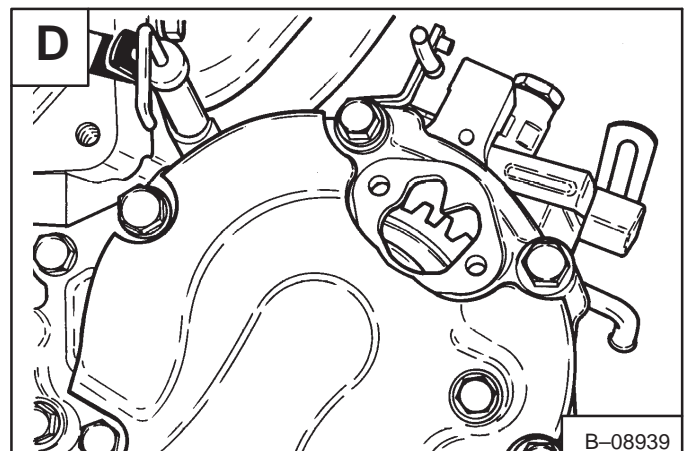

FUEL INJECTION PUMP (Cont'd)

Removal And Installation (Cont'd)

IMPORTANT

Do not bend the high pressure fuel injection tubes when removing or installing them.

I-2029-0289

Disconnect the high pressure fuel lines at the injection pump [A].

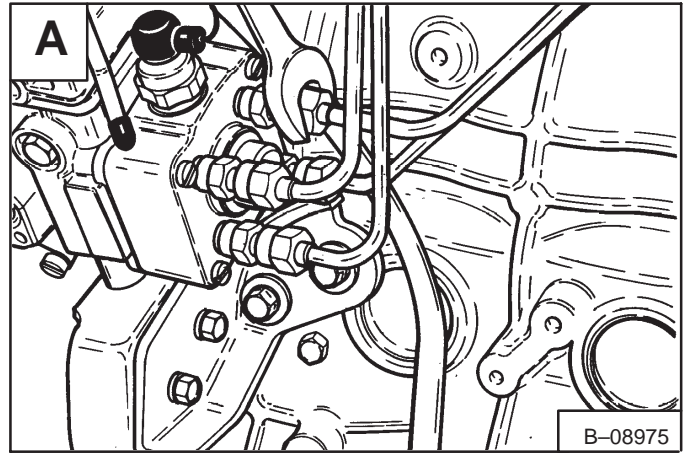

Disconnect the fuel lines at the injectors [B].

Installation: Tighten the fittings on the high pressure fuel lines to 14–29 ft.-lbs. (19–39 Nm) torque.

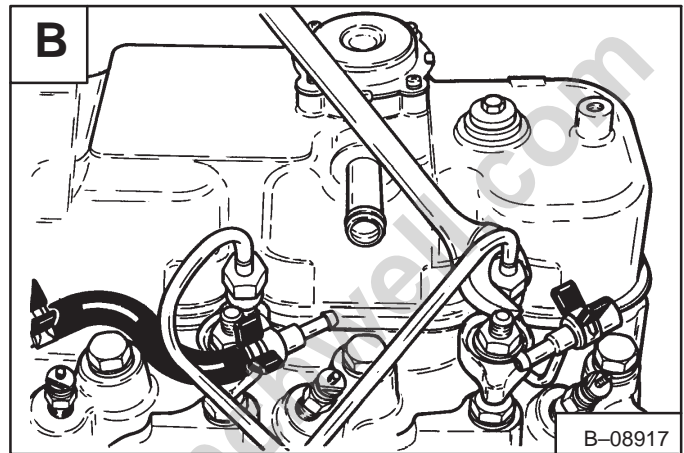

Remove the high pressure fuel lines from the engine [C].

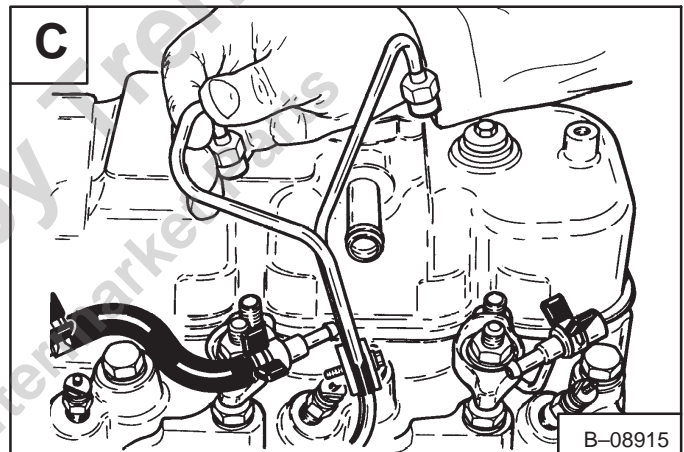

Align the mark in the window before removing the injection pump [A].

Remove the bolts at the front of the timing case cover [D].

Installation: Tighten bolts & nuts to 10–17 ft.-lbs. (14–23 Nm) torque.

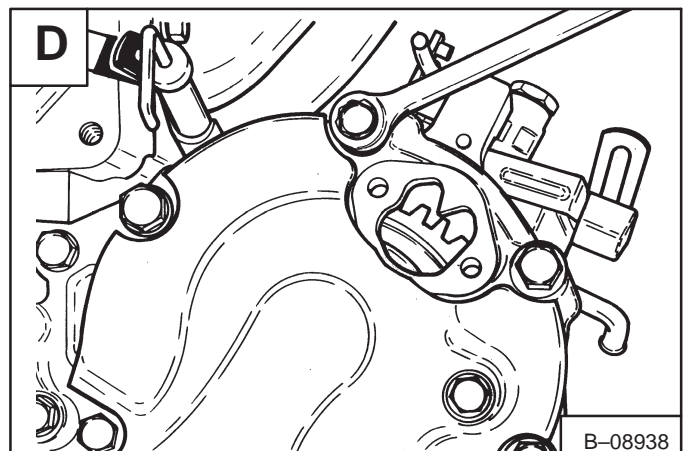

FUEL INJECTION PUMP (Cont'd)

Removal And Installation (Cont'd)

Remove the fuel injection pump [A].

Installation: After the injection pump is installed, the air must be removed from the fuel system. (See Page 1-1.)

Also the injection pump timing must be set. (See Page 7-46.)

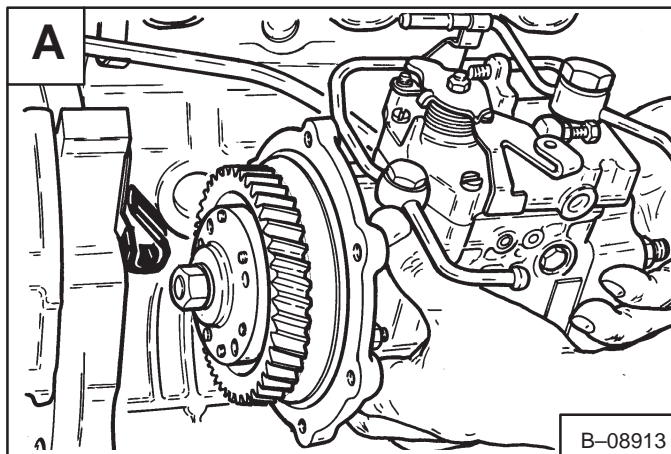

Provided for Free by Trenchwell.com
Shop Aftermarket Parts

FUEL INJECTION PUMP (Cont'd)

Timing The Injection Pump

The tools listed will be needed to do the following procedure:

MEL1201 – Timing Tool

Remove the valve cover.

Rotate the engine until No. 1 piston is at TDC. Both valves at No. 1 cylinder are not moving and have clearance [A].

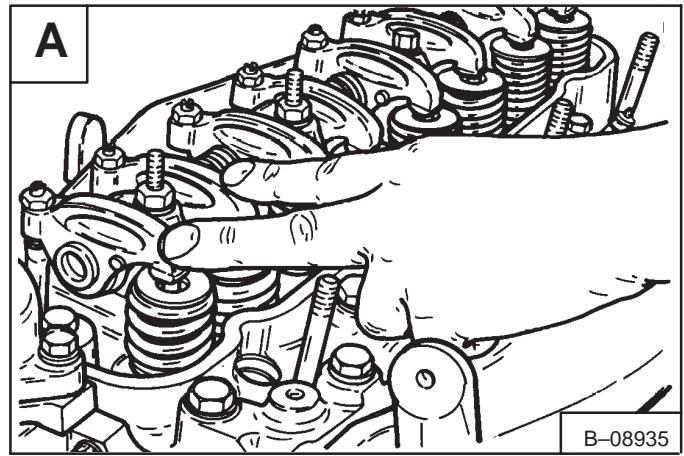

The TDC mark (Item 1) [B] is located on the engine pulley v-belt groove.

There are two sets of timing marks on the engine pulley one at 12 o'clock and the other at the 3 o'clock position. Use the timing mark located at the 3 o'clock position (Inset) [B].

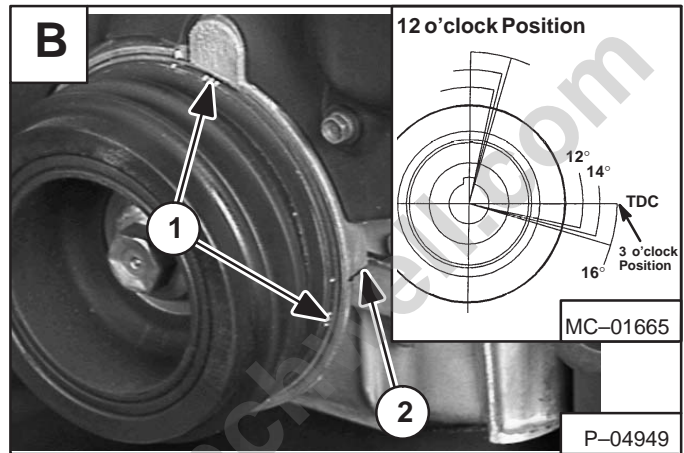

Use the parting line (off-set) (Item 2) [B] or (Item 1) [C] of the timing case cover to make alignment of the TDC mark.

Disregard the pointer (Item 2) [C] in the belt shield for timing reference.

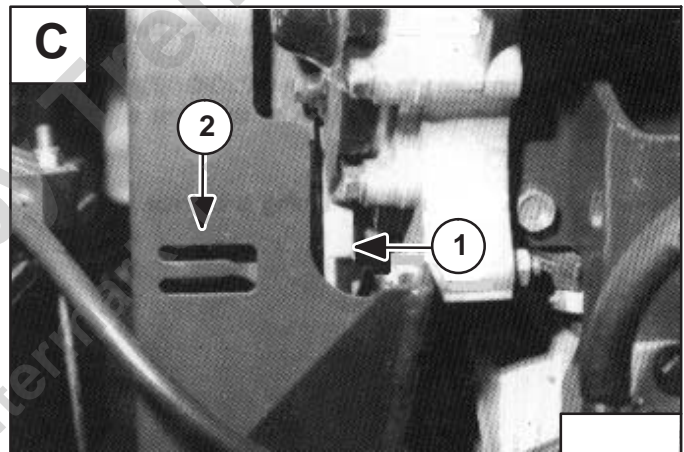

Remove the plug at the rear of the injection pump [D].

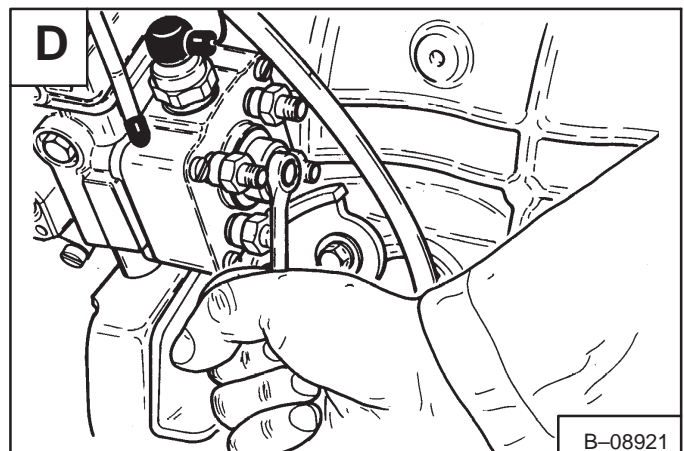

FUEL INJECTION PUMP (Cont'd)**Timing The Injection Pump (Cont'd)**

Install the timing tool and dial indicator **[A]**.

Rotate the engine counterclockwise so the front pulley mark goes 30° to 40° before TDC.

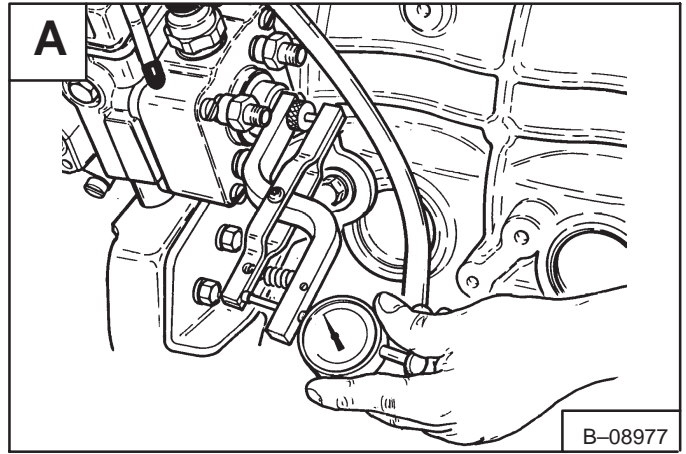

Set the dial indicator to zero **[B]**.

Rotate the engine back to 17° BTDC mark on the front pulley.

The dial indicator must read approximately 0.020 inch (0,50 mm) **[B]**.

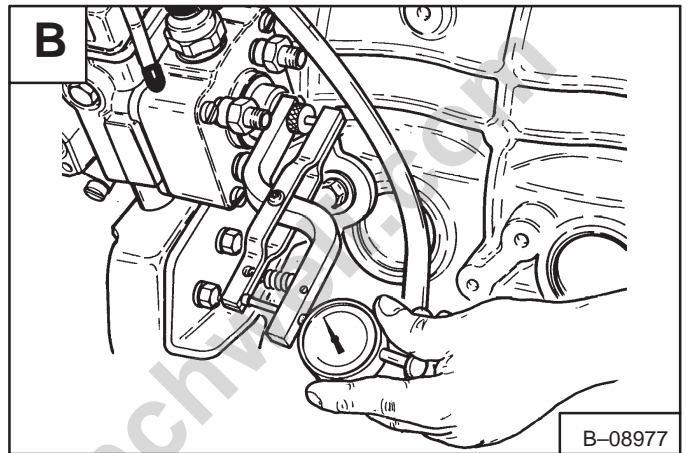

If not, loosen the bolts at the injection pump flange **[C]**.

Move the injection pump to obtain the 0.020–0.022 inch (0,51–0,59 mm) reading at the dial indicator with the front pulley marks at the 17° BTDC.

Repeat the procedure until the timing is correct.

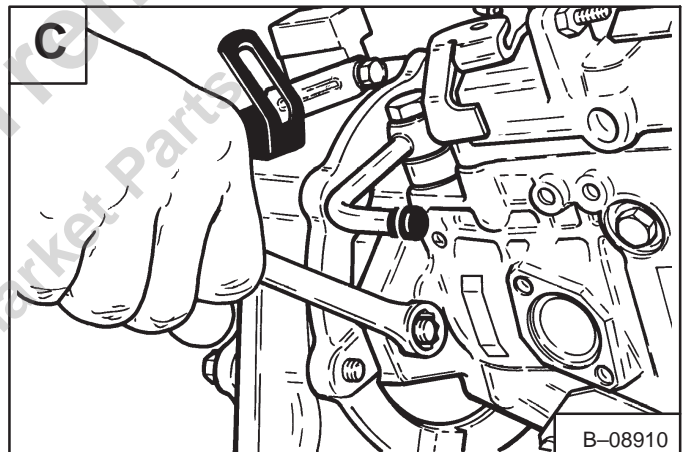

FUEL INJECTOR NOZZLES

Removal And Installation



WARNING

Diesel fuel or hydraulic fluid under pressure can penetrate skin or eyes causing serious injury. Fluid leaks under pressure may not be visible. Use a piece of cardboard or wood to find leaks. Do not use your bare hand. Wear safety goggles. If fluid enters skin or eyes, get immediate medical attention.

W-2074-1285

Some problems caused by faulty injector nozzles:

The engine is hard to start or will not start.

Rough engine operation and idle.

The engine will not have full power.

The engine exhaust smoke is black, white or blue.

IMPORTANT

Do not bend the high pressure fuel injection tubes when removing or installing them.

I-2029-0289

Disconnect the high pressure fuel lines at the fuel injection pump [A].

Installation: Tighten the fittings on the high pressure fuel lines to 14–29 ft.-lbs. (19–39 Nm) torque.

Disconnect the fuel lines at the fuel injectors [B].

Remove the high pressure fuel lines from the engine [C].

Remove the low pressure hoses from the fuel injector nozzles [D].

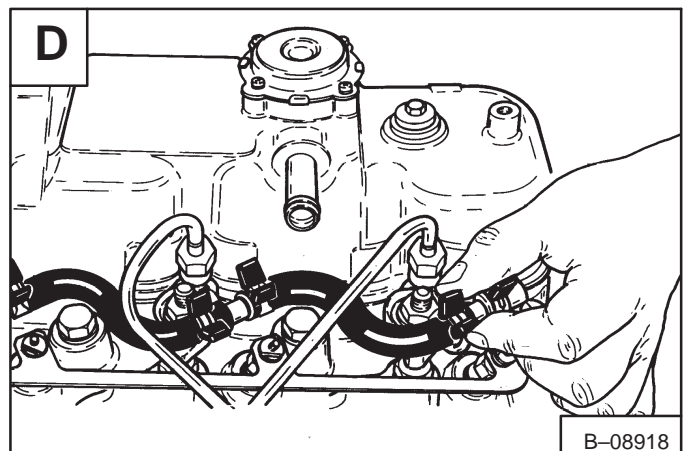
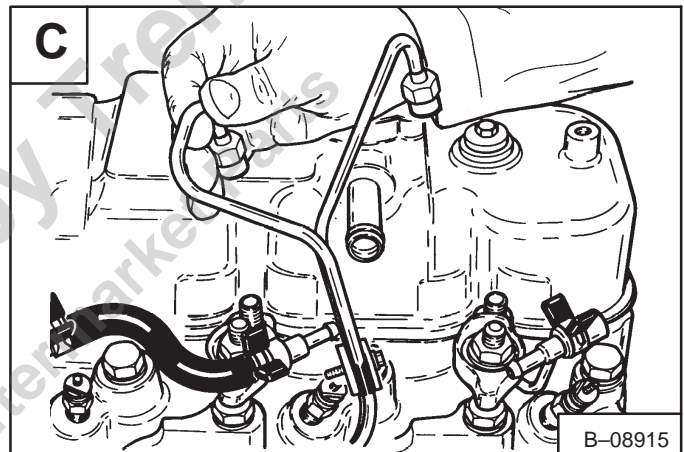
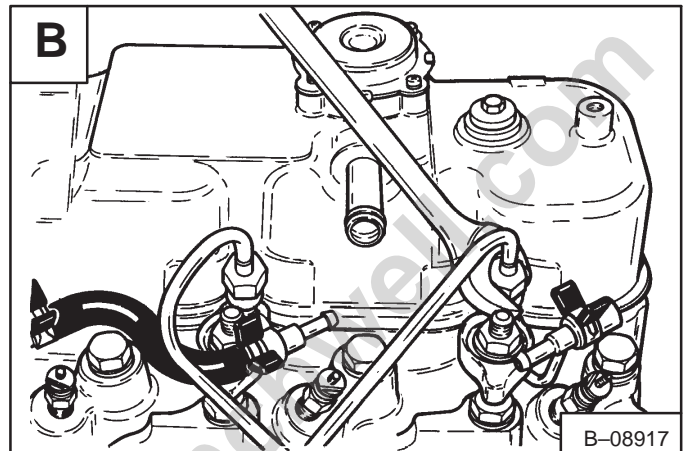
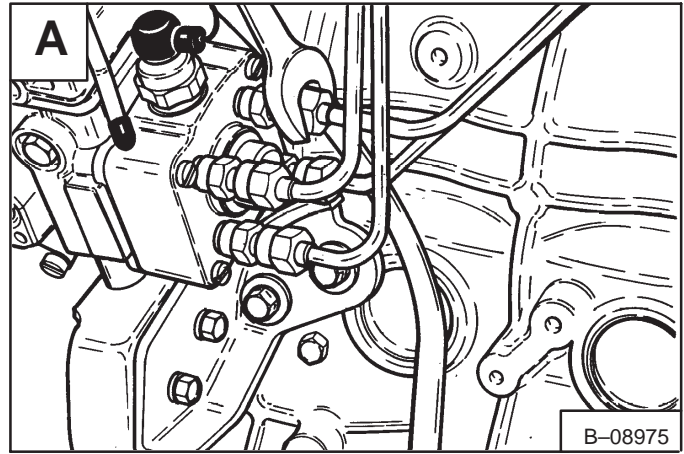

FUEL INJECTOR NOZZLES (Cont'd)**Removal And Installation (Cont'd)**

Remove the nut at the fuel injector holddown clamp [A].

Installation: Tighten the nuts to 23–32 ft.-lbs. (31–43 Nm) torque.

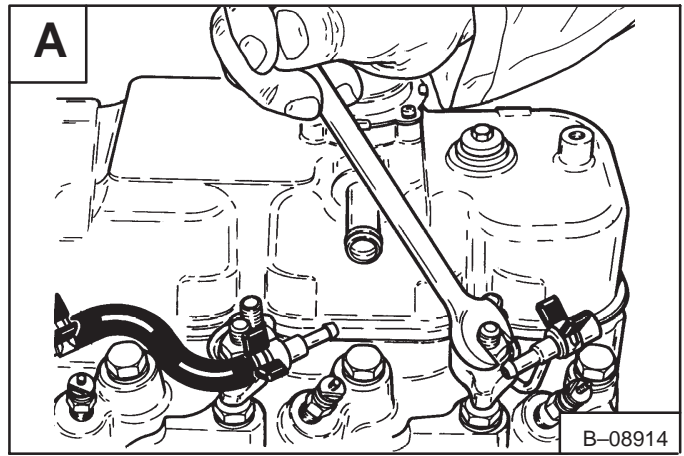

Use a screwdriver and pry the injector from the cylinder head [B].

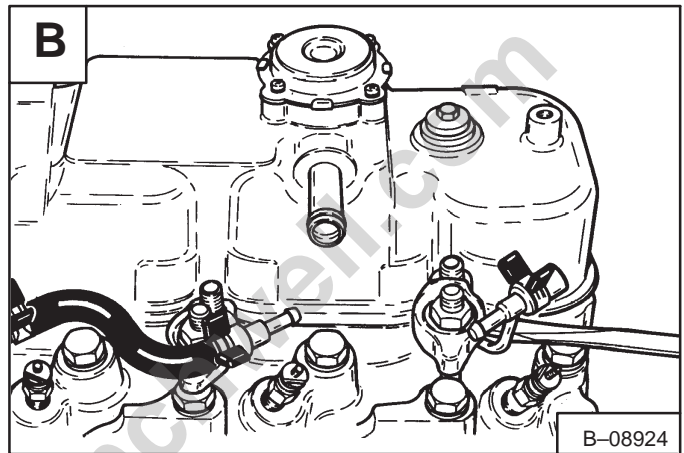

Remove the injector nozzle from the head [C].

Checking**IMPORTANT**

Do not disassemble or test the fuel injector nozzles unless you have the correct service and testing tools.

I-2027-0284

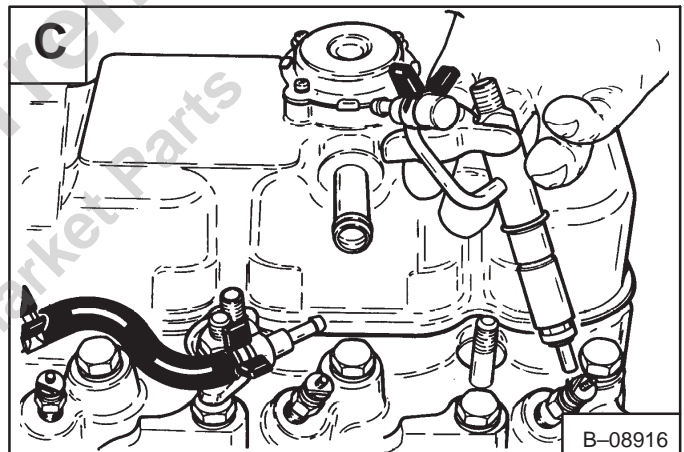

The tools listed will be needed to do the following procedure:

OEM1064 – Injection Nozzle Tester
OEM1065 – Accessory Set

Connect the nozzle to the test pump, in a down position [D].

Operate the test pump until the nozzle valve opens:

Injection Pressure: 2630 PSI (18134 kPa)

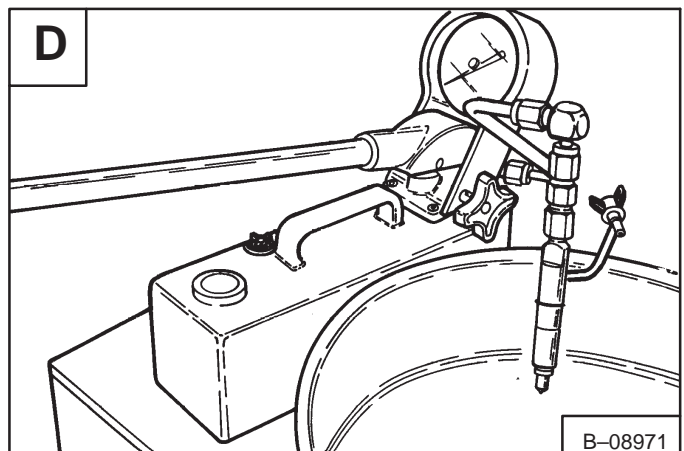

FUEL INJECTOR NOZZLES (Cont'd)

Checking (Cont'd)

If the pressure is not correct, do the following:

Disassemble the injector nozzle and clean.

Replace the shim (Item 6) [A].

Check the pressure again.

! WARNING

Keep away from fuel under pressure in injector system. It may not be visible. Wear safety goggles. Fuel under pressure can penetrate skin or eyes causing serious injury. If fluid enters skin or eyes, get immediate medical attention.

W-2072-1285

Tighten the retaining nut (Item 1) [A] when assembling the injector nozzle to 29–32 ft.-lbs. (39–43 Nm) torque.

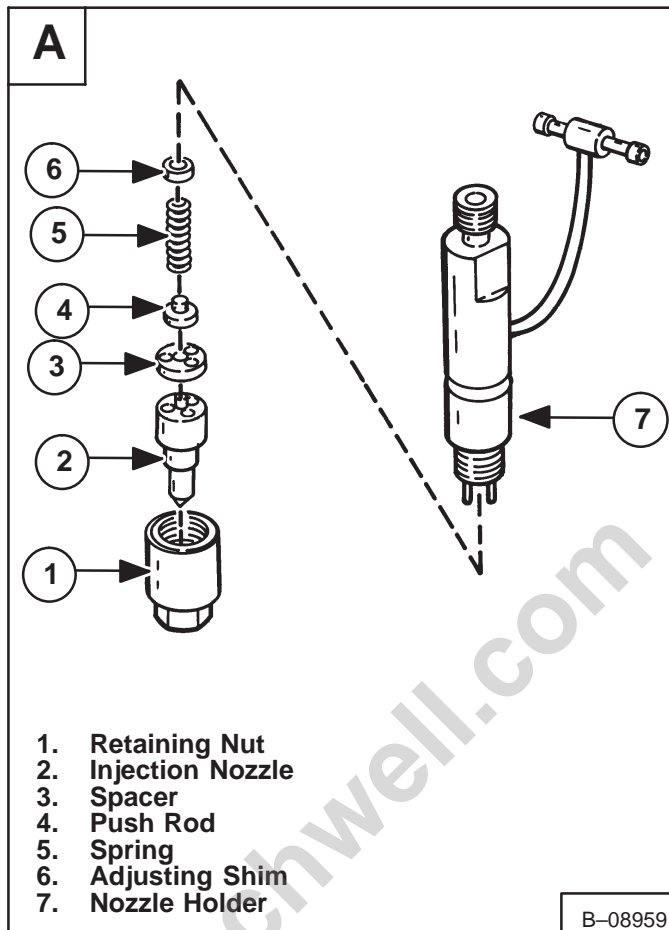

Checking nozzles spray pattern [B]:

Does not come out the side of the nozzle. Does not have drops coming from the nozzle. Does not have a solid stream coming from nozzle.

Any of the above conditions show a defect or dirty injector nozzle. Clean or replace any injector nozzle that does not operate correctly.

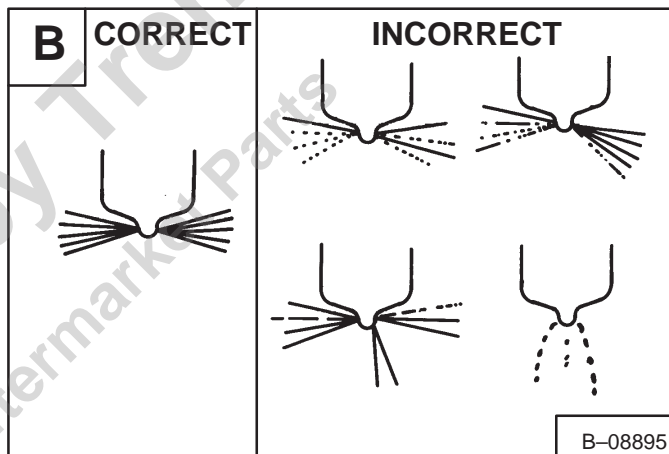

Provided for Free by TractorParts.com

Shop Aftermarket Parts

CYLINDER HEAD

Removal And Installation

The tools listed will be needed to do the following procedure:

MEL1267 – Cylinder Head Bolt Wrench

Clean all the debris from the cylinder head and engine.

Remove the coolant from the engine and radiator.
Remove the radiator hoses.

Remove the fuel injectors and fuel tubelines. (See Page 7–48.)

Remove the valve cover nuts in the correct sequence [A].

Installation: Tighten the nuts to 6–13 ft.-lbs. (8–17 Nm) torque in the correct sequence [A].

Remove the rocker arm assembly bolts in the correct sequence [B].

Installation: Tighten the bolts in the correct sequence to 36–43 ft.-lbs. (49–58 Nm) torque.

Remove the cylinder head bolts in the correct sequence [C].

Installation: Lubricate the bolts and tighten them in two steps as listed, in the correct numerical sequence [D].

	Step 1	Step 2
New Bolts	29 ft.-lbs. (39 Nm)	59–67 ft.-lbs. (80–91 Nm)
Used Bolts	62 ft.-lbs. (83 Nm)	72–80 ft.-lbs. (97–108 Nm)

NOTE: When removing the head, do not use a sharp tool between the head and the engine block. Always put the cylinder head on a flat surface, such as wood, to prevent damage to the machined surface.

Remove the head from the engine.

See Page 7–53 for removing and reconditioning the valves.

After the cylinder head is installed, adjust the valve clearance. (See Page 7–41.)

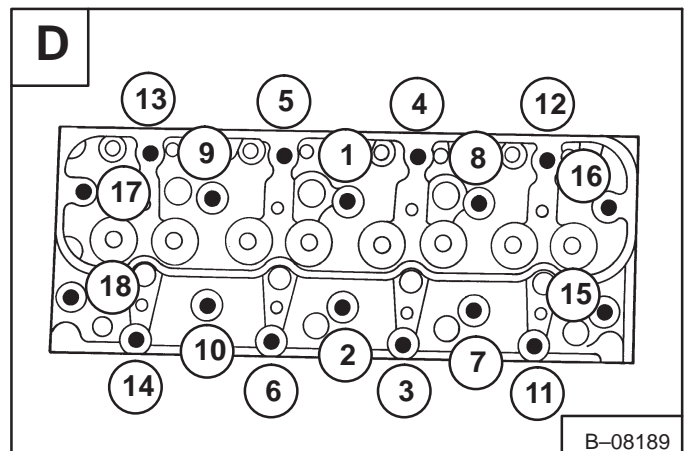
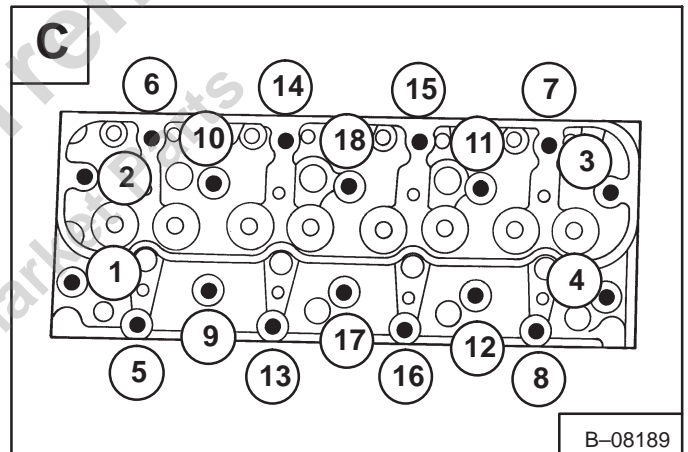
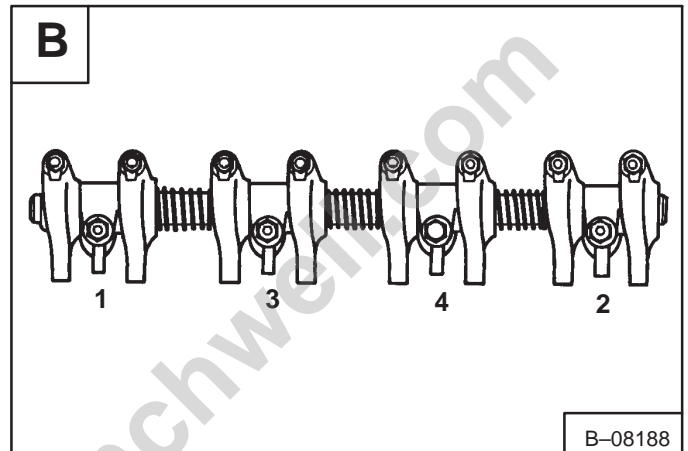
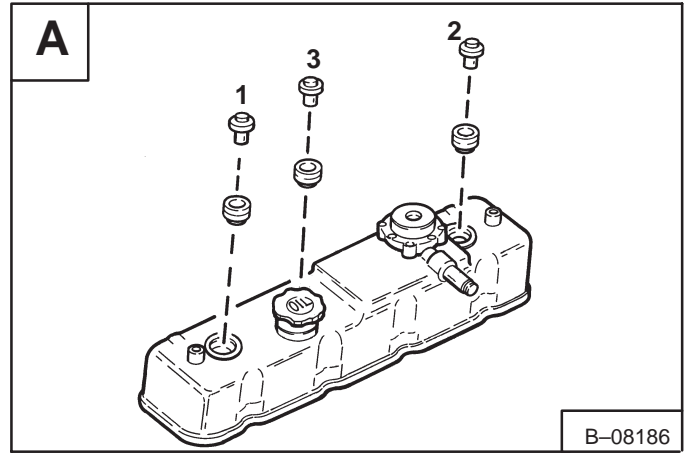

CYLINDER HEAD (Cont'd)**Cylinder Head Surface Alignment**

Check the surface of the head with the straight edge [A].

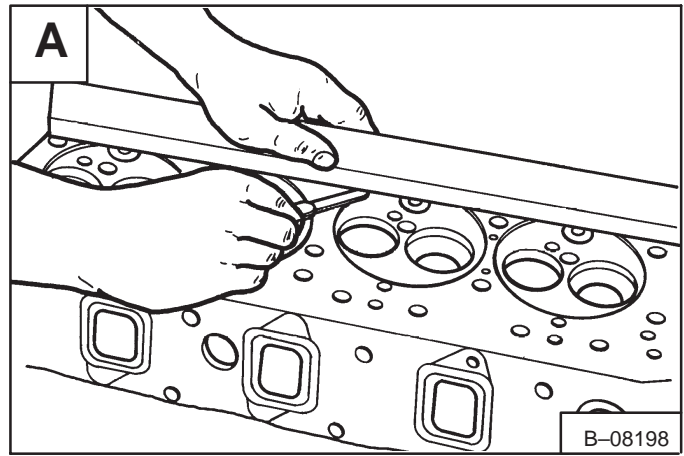

Check the head at six different directions [B].

The standard distortion is 0.002 inch (0,05 mm) and the maximum limit is 0.008 inch (0,20 mm).

When the head distortion exceeds the maximum limit, regrind the head with a maximum limit of 0.012 inch (0,30 mm).

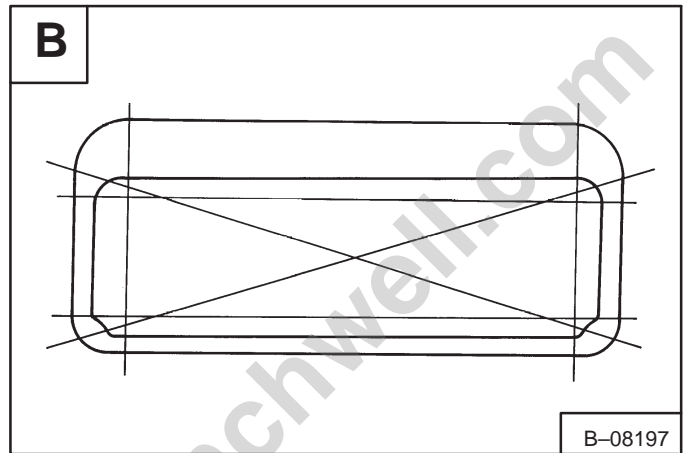
**Exhaust Manifold**

If the exhaust manifold has been removed, use the correct torque sequence and tighten the bolts to 10–17 ft.-lbs. (14–23 Nm) torque [C].

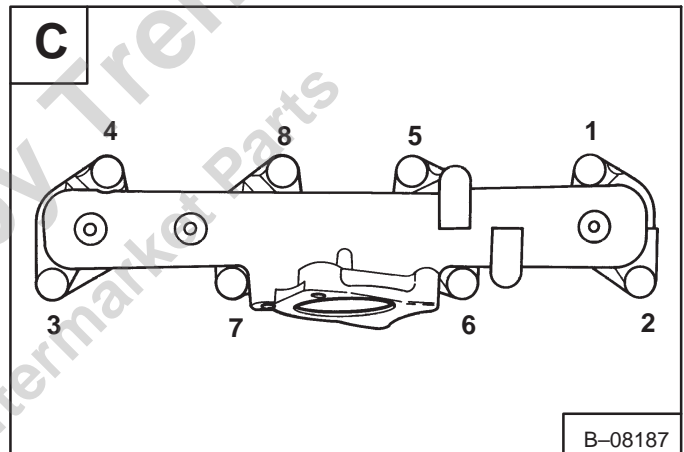

VALVES, VALVE SEAT AND GUIDE

Removal

The tools listed will be needed to do the following procedure:

MEL1266 – Valve Stem Seal Installer

Mark the valves and parts so they are returned to their original position when assembling.

Remove the valve spring locks [A], using a spring compressor [B].

Remove the valve springs, spring seats, oil seal and valve [A].

Before reassembly, check the valves, valve seats and guides.

Installation

Make sure the head is clean.

Put oil on the valve guides and valve stems.

Put each valve in the correct location.

Install the valve springs, spring seats and oil seals [A].

NOTE: Install the valve springs with their closed pitched (painted) end toward the cylinder head.

Use a valve spring compressor and install the valve spring locks.

Tap the valve stem with a hammer a small amount to seat the valve stem locks.

Reconditioning The Valve And Valve Seats

Use the correct equipment to grind the valve and valve seats.

The angle of the intake and exhaust valves is 45° [C].

The valve head thickness is as listed [C]:

Standard – 0.071 inch (1,8 mm)

Limit – 0.059 inch (1,5 mm)

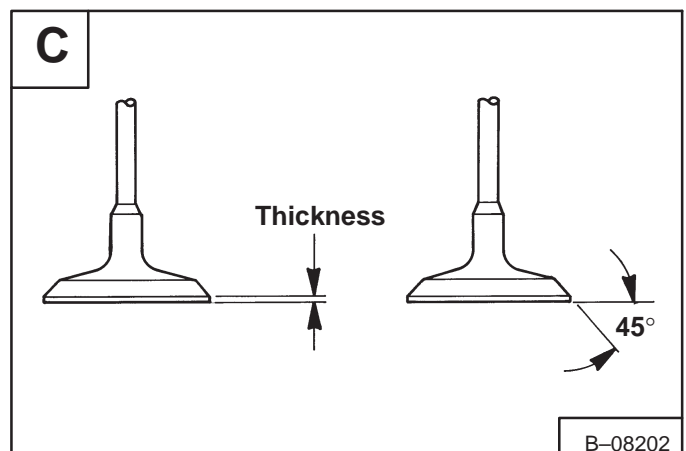
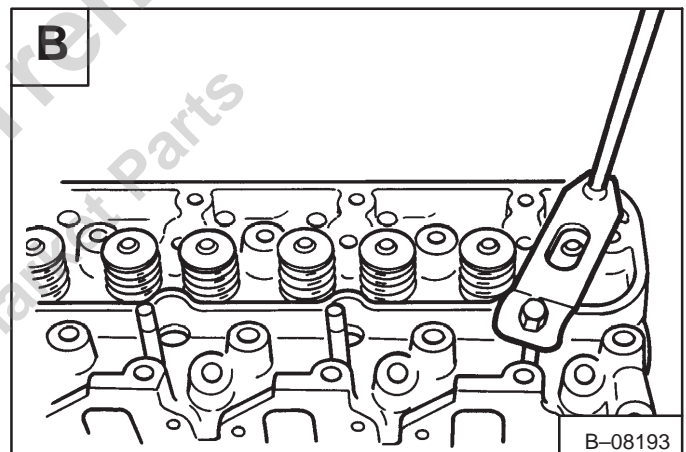
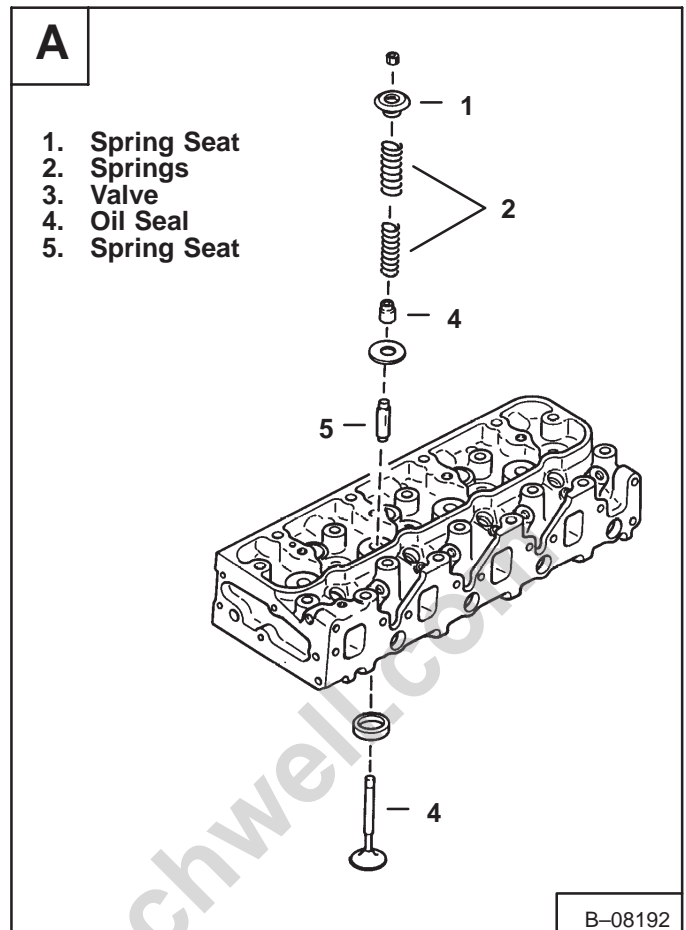

VALVES, VALVE SEAT AND GUIDE (Cont'd)

Reconditioning The Valve And Valve Seats (Cont'd)

Check the valve head depth in the cylinder head after grinding the valves and seat. The correct specifications are as follows[A]:

Intake – Standard	0.029 inch (0,74 mm)
Limit	0.05 inch (1,27 mm)
Exhaust – Standard	0.028 inch (0,71 mm)
Limit	0.047 inch (1,20 mm)

Check the valve seat contact width [A]:

Intake – Standard	0.067 inch (1,70 mm)
Limit	0.087 inch (2,21 mm)
Exhaust – Standard	0.079 inch (2,0 mm)
Limit	0.098 inch (2,48 mm)

Valve Seat Insert

To remove the valve seat insert, put a bead of weld around the inner face of the insert and allow to cool a few minutes, then pry them out [B].

Press the new valve seat insert into the bore using a hydraulic press.

After installation, grind the insert to the correct angle and check the depth of the valve.

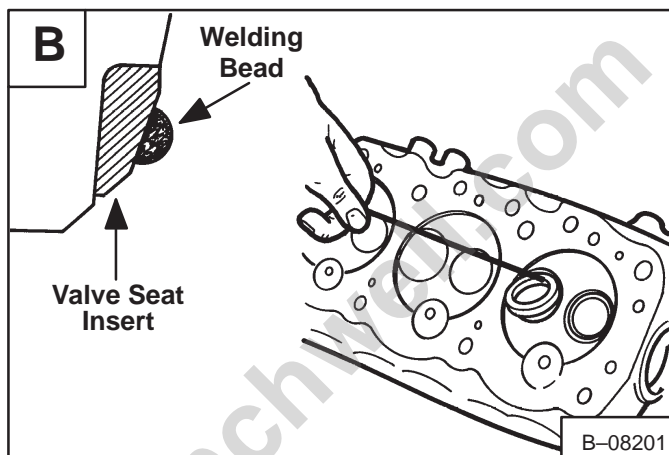
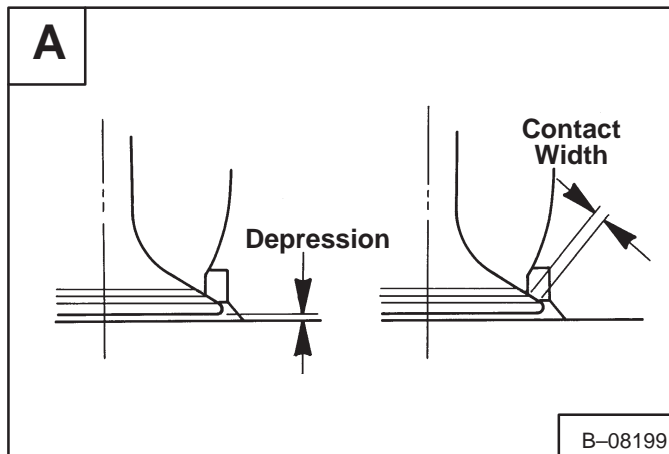

Valve Guide

The tools listed will be needed to do the following procedure:

MEL1259 – Valve Guide Remover

Check the valve guides for wear with a dial indicator [C].

If the movement is more than the listed specifications, replace the guide.

Intake – Standard	0.0015–0.0027 inch (0,038–0,069 mm)
Limit	0.008 inch (0,2 mm)

Exhaust – Standard	0.0025–0.0038 inch (0,064–0,96 mm)
Limit	0.010 inch (0,25 mm)

NOTE: Check the valve stem for wear before replacing the valve guide [D].

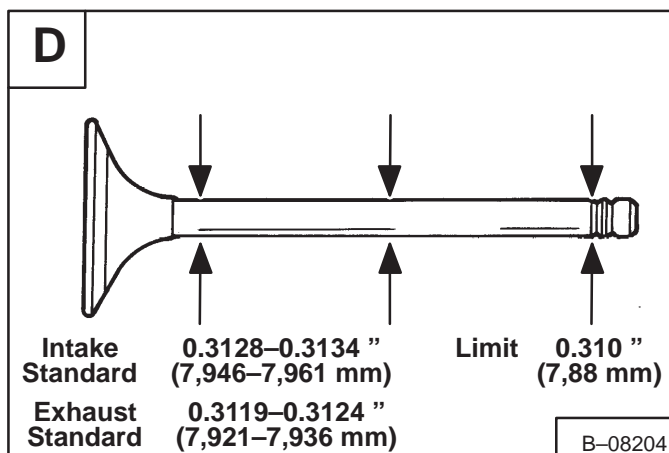
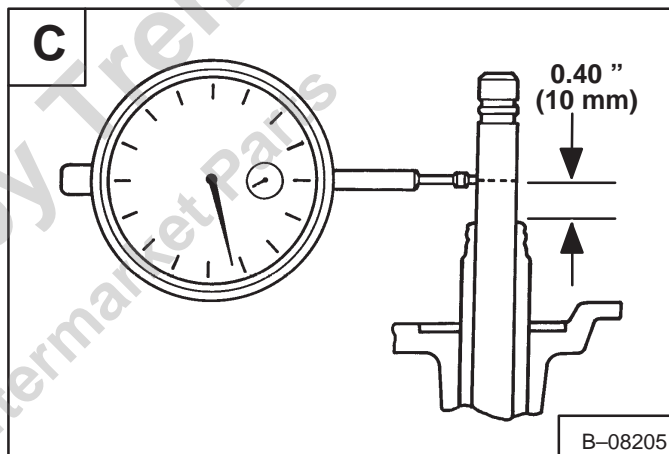

VALVES, VALVE SEAT AND GUIDE (Cont'd)

Valve Guide (Cont'd)

Remove the guide [A].

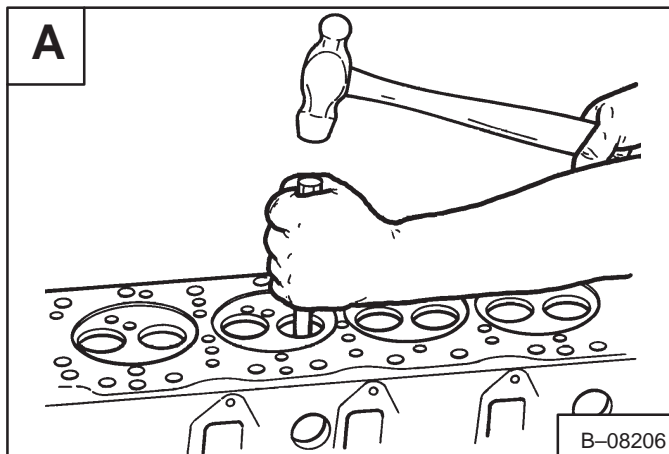

Install the new guide [B].

The height of the valve guide top edge to the cylinder is 0.51 inch. (13,0 mm).

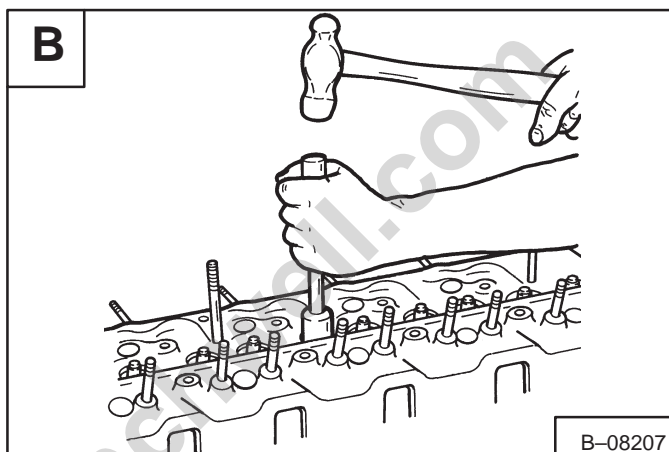

Valve Spring

Check the free length and inclination [C].

		Std.	Limit
Free Length	Inner	1.783 inch (45,3 mm)	1.748 inch (44,4 mm)
	Outer	1.957 inch (49,7 mm)	1.898 inch (48,2 mm)
Inclination	Inner	—	0.118 inch (3,0 mm)
	Outer	—	0.126 inch (3,2 mm)

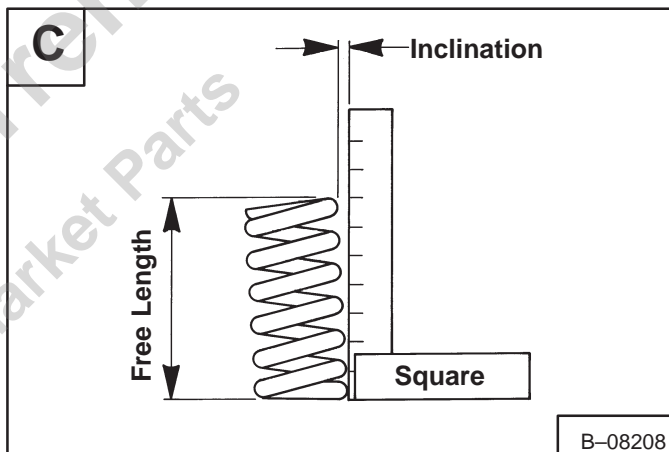

Check the valve spring tension [D].

	Set Length	Std.	Limit
Inner	1.46 inch (37,0 mm)	13 lbs. (5,9 kg)	11 lbs. (5,02 kg)
Outer	1.54 inch (39,1 mm)	46 lbs. (20,9 kg)	40 lbs. (18,1 kg)

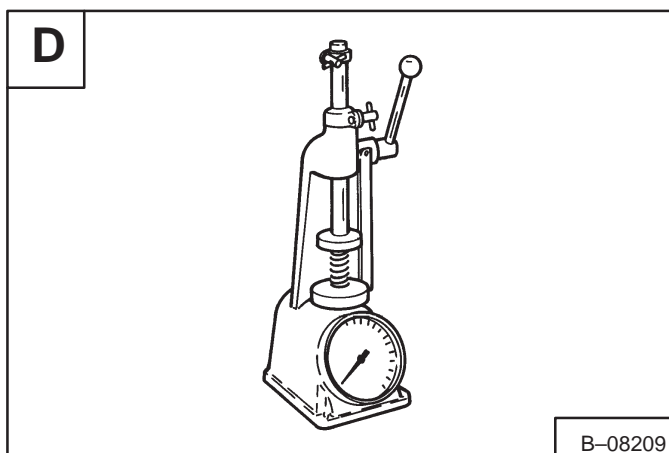

ROCKER ARM AND SHAFT

Disassembly And Assembly

Mark the rocker arms and support brackets for correct assembly.

Remove the snap ring (Item 1) [A] from each end of the shaft (Item 5) [A].

Remove the rocker arms (Items 2 & 4) and support brackets (Item 3) [A].

Assembly: The support bracket with the oil hole is toward the front of the engine.

Inspect all the parts for wear or damage.

Check the rocker arm O.D. [B].

Standard – 0.7478–0.7486 inch (18,98–19,0 mm)
Limit – 0.7427 inch (18,85 mm)

Checking Rocker Arm And Push Rods

Check the rocker arm [C].

Rocker arm diameter.

Standard – 0.7489–0.7497 inch (19,01–19,03 mm)
Limit – 0.7505 inch (19,05 mm)

Clearance between rocker arm and shaft.

Standard – 0.0003–0.002 inch (0,008–0,051 mm)
Limit – 0.0078 inch (0,20 mm)

Replace the parts as needed.

Check the push rods for run-out [D].

Limit – 0.012 inch (0,3 mm)

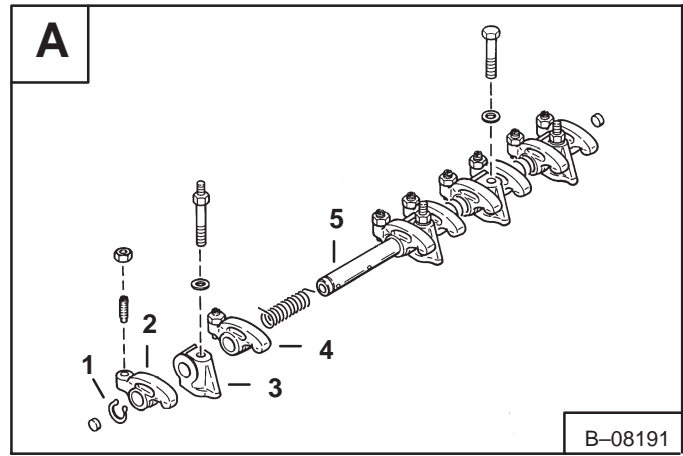

B-08191

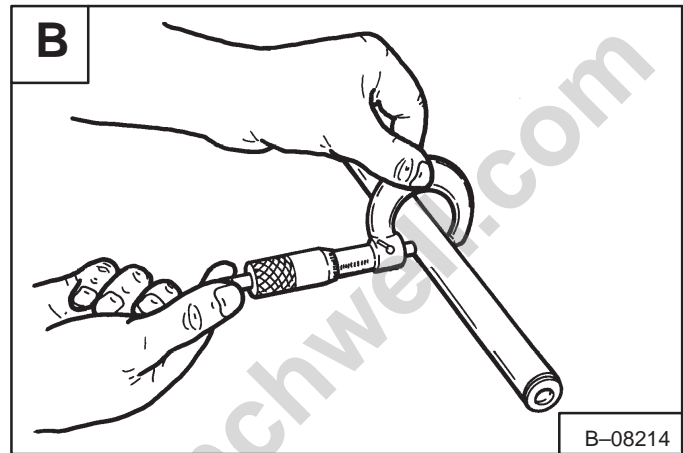

B-08214

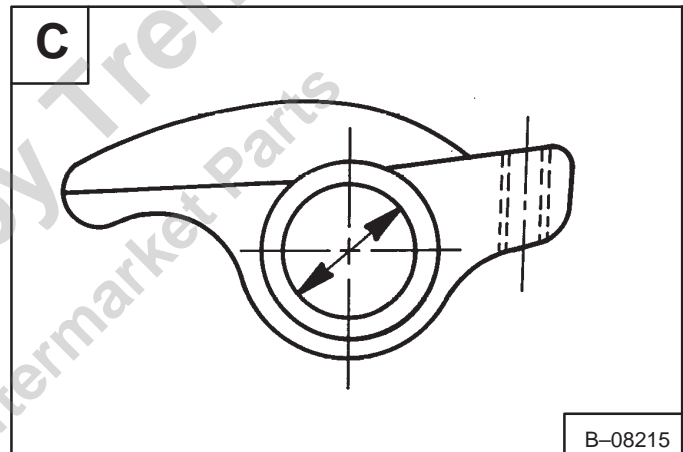

B-08215

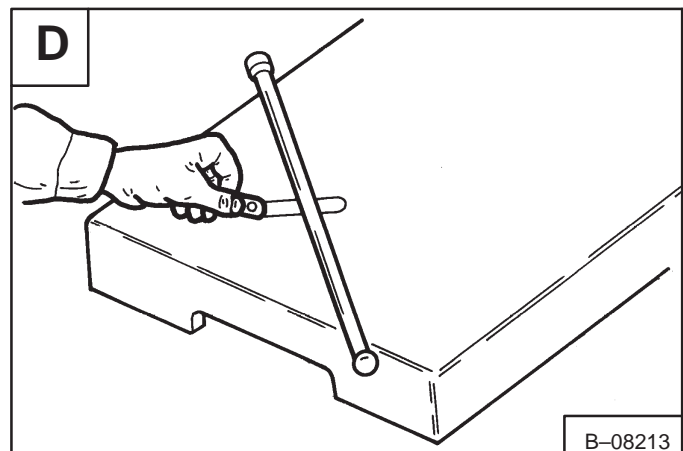

B-08213

PISTON AND CONNECTING ROD

Removal

Remove the cylinder head. (See Page 7-51.)

Remove the oil pan. (See Page 7-81.)

Remove the ridge and carbon deposits at the top of the cylinder bore with a ridge reamer.

Make sure the pistons have identification marks **[A]**.

Rotate the crankshaft until a pair of connecting rods are at the bottom dead center. Make sure the connecting rod caps and the rods have identification marks.

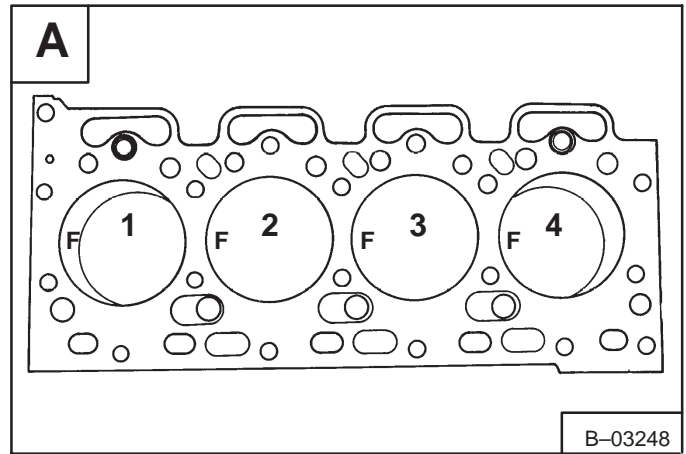

Remove the nuts and remove the bearing caps **[B]**.

NOTE: If the bearings are to be used again, they must be identified so they are returned to their original location.

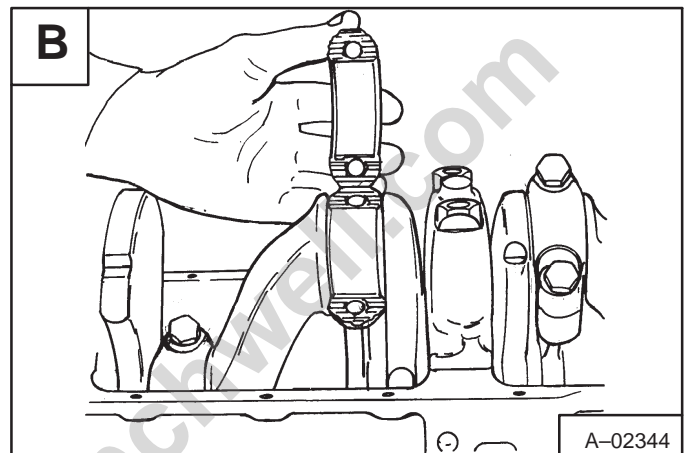

Using a hammer handle, push the piston and rod out of the block **[C]**.

After the pair has been removed, rotate the engine crankshaft and remove the other pair of pistons.

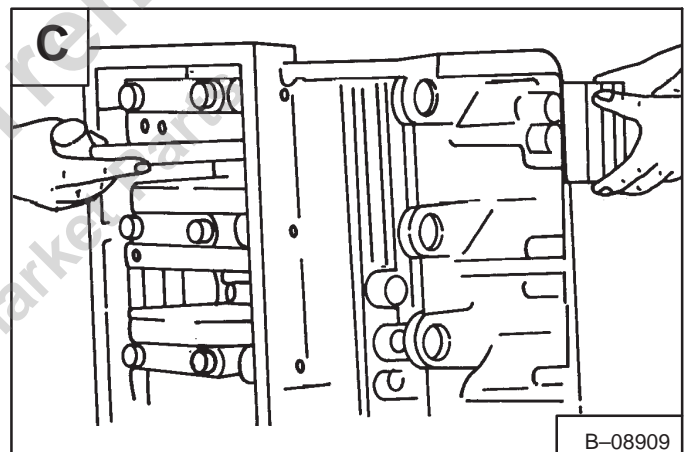

Disassembly

Remove the rings from the pistons **[D]**.



PISTON AND CONNECTING ROD (Cont'd)

Disassembly (Cont'd)

Remove the piston pin snap ring [A].

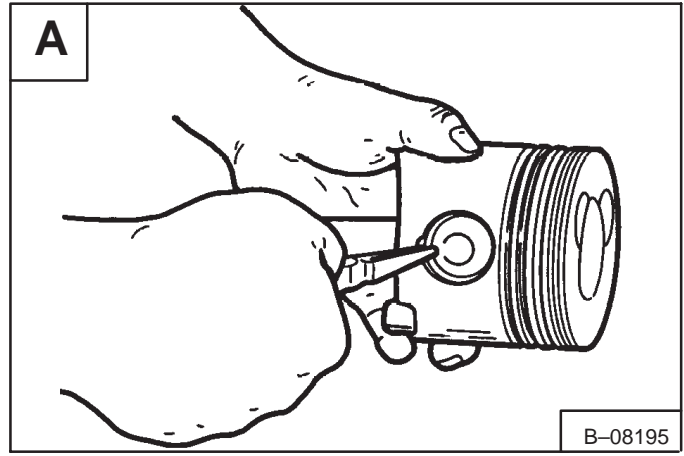

Drive out the piston pin using a brass rod [B].

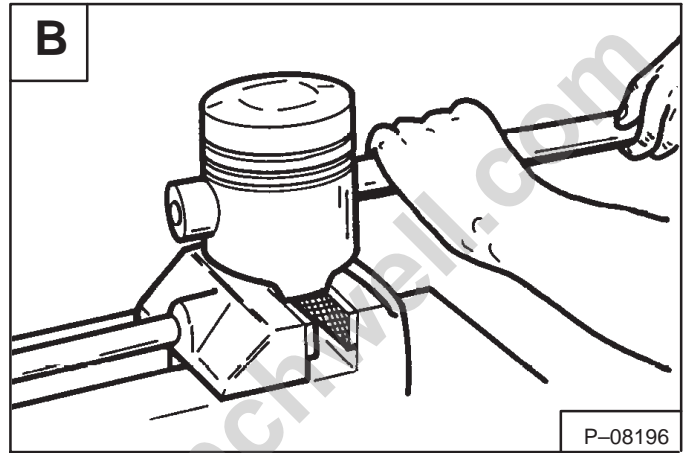

Checking

Clean all the parts in clean solvent.

Check the clearance of the new rings in the piston grooves [C].

	Standard	Limit
1st Compression	0.0035–0.0049 inch (0,09–0,125 mm)	0.006 inch (0,15 mm)
2nd Compression	0.002–0.0033 inch (0,05–0,085 mm)	0.006 inch (0,15 mm)
Oil	0.001–0.003 inch (0,03–0,07 mm)	0.006 inch (0,15 mm)

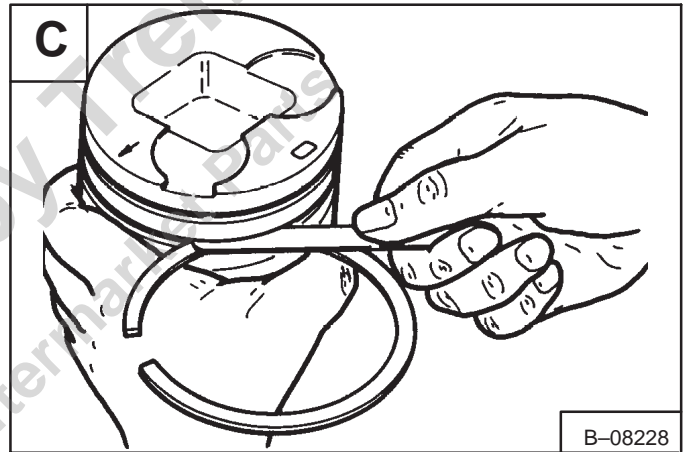

Check the piston diameter [D].

Pistons are available in two sizes.

Piston Grade A 3.6608–3.6616 inch
(92,985–93,004 mm)

Piston Grade C 3.6616–3.6624 inch
(93,005–93,024 mm)

Refer to parts fiche when ordering pistons, piston rods and cylinder liners.

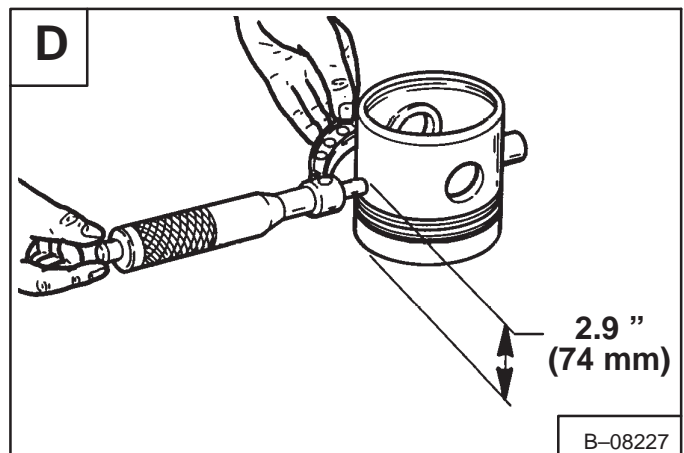

PISTON AND CONNECTING ROD (Cont'd)

Checking (Cont'd)

Check the ring gap in the cylinder bore **[A]**.

	Standard	Limit
Compression	0.008–0.016 inch (0,20–0,40 mm)	0.059 inch (1,50 mm)
Oil	0.004–0.012 inch (0,10–0,30 mm)	0.059 inch (1,50 mm)

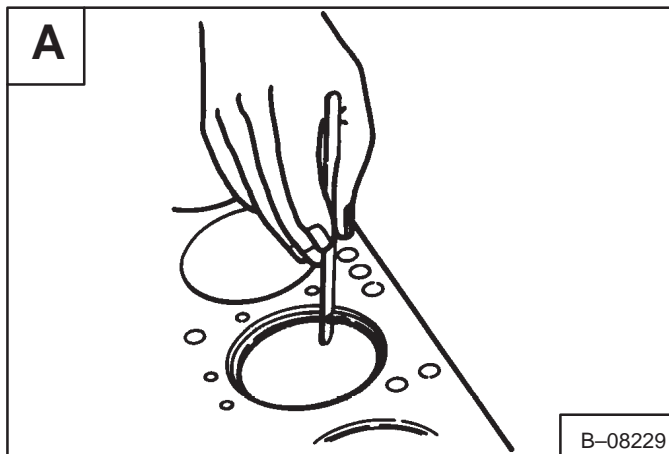

Check the piston pin diameter **[B]**.

Standard – 1.220 inch (31,0 mm)
Limit – 1.219 inch (30,97 mm)

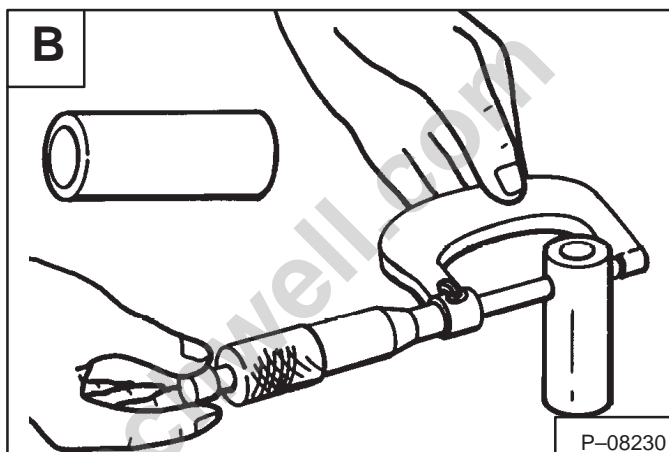

Check the clearance between piston pin and piston pin bore **[C]**.

Clearance – 0.00008–0.00006 inch
(0,002–0,015 mm)

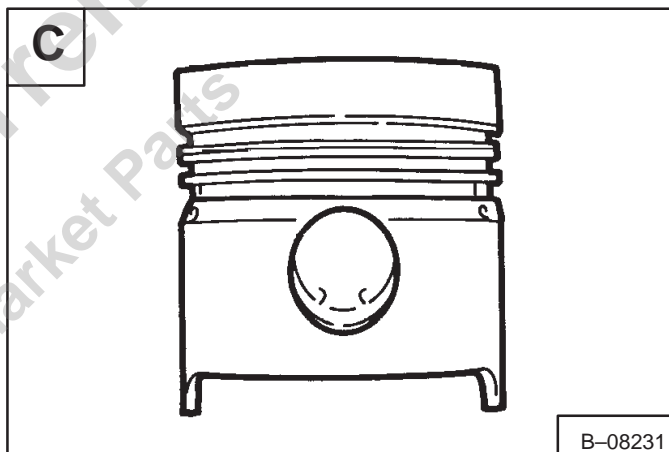

Check the connecting rod alignment **[D]**.

Standard – 0.002 inch (0,50 mm) or less
Limit – 0.0079 inch (0,20 mm)

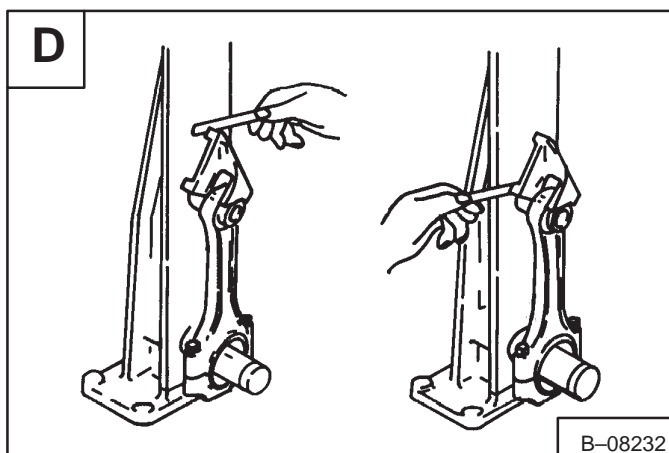

PISTON AND CONNECTING ROD (Cont'd)**Checking (Cont'd)**

Check the connecting rod small end bushing **[A]**.

Standard – 1.2208–1.2211 inch (31,008–31,015 mm)

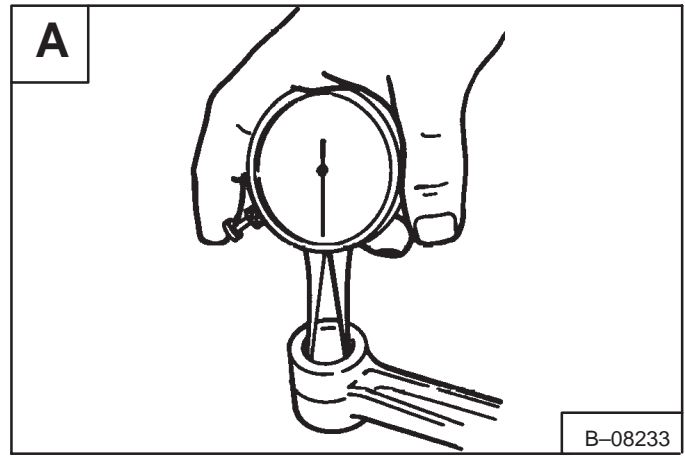

Check the clearance between the piston pin and connecting rod **[B]**.

Standard – 0.0003–0.00079 inch (0,008–0,02 mm)

Limit – 0.0002 inch (0,5 mm)

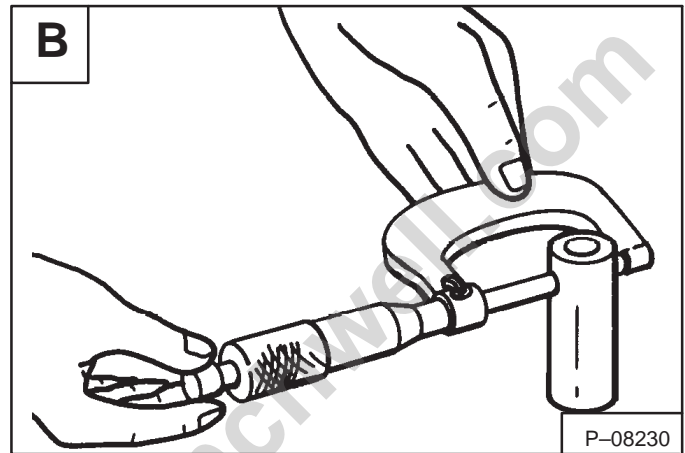

Replace the small end bushing if not within specifications using a hydraulic press **[C]**.

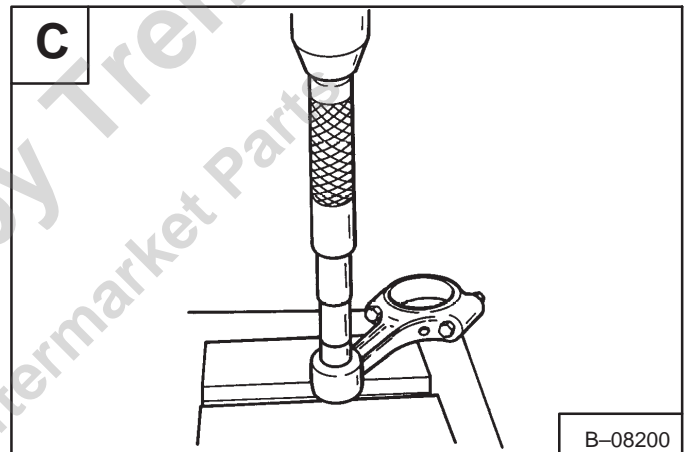

After installation of a new bushing, finish the bushing bore to the correct specifications **[D]**.

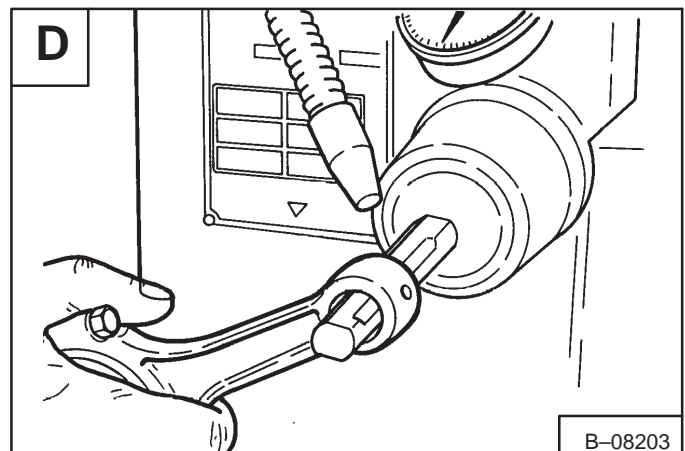

PISTON AND CONNECTING ROD (Cont'd)**Assembly**

Heat the piston to about 140°F (60°C) **[A]**.

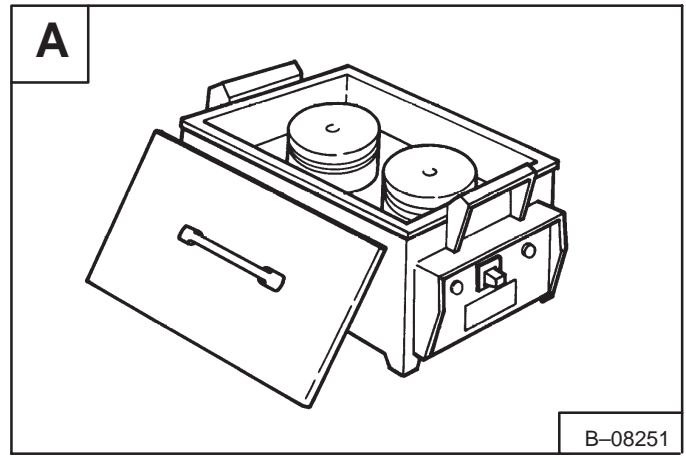

Assemble the piston and connecting rod **[B]**.

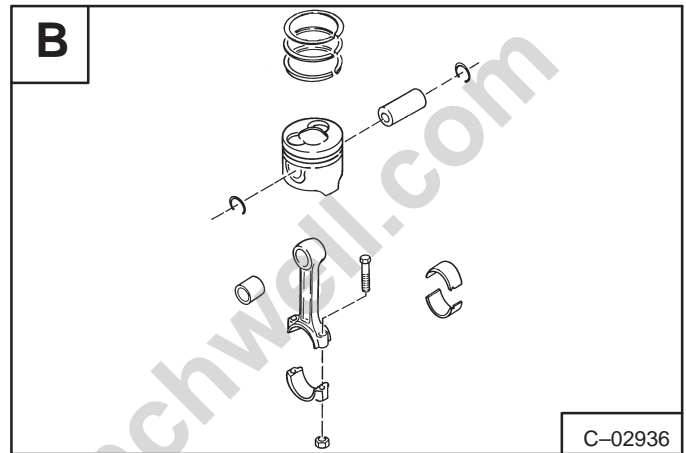

Install the piston to the connecting rod. The piston head front mark (Item 1) **[C]** and the connecting rod "ISUZU" casting mark (Item 2) **[C]** must be facing the same direction.

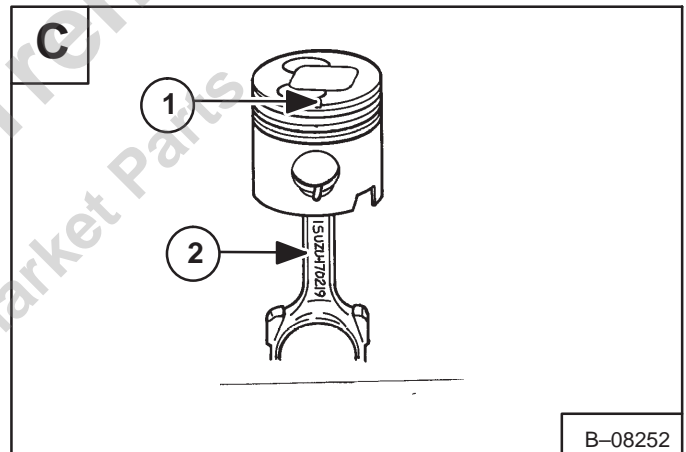

Install the piston pin. Install the snap rings **[D]**.

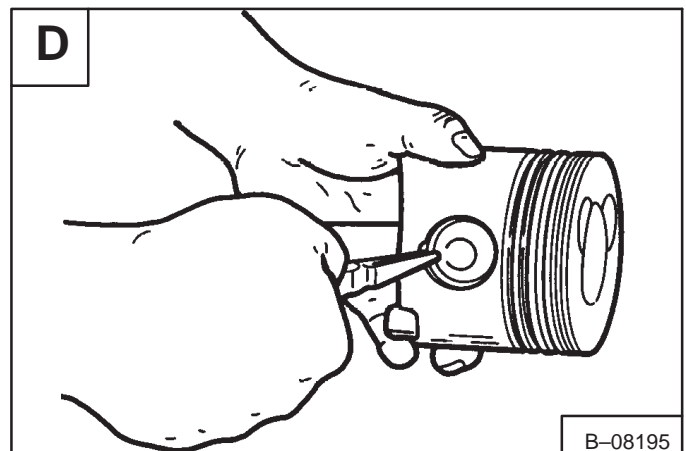

PISTON AND CONNECTING ROD (Cont'd)**Assembly (Cont'd)**

Install the rings on the piston [A].

The face with the mark NPR or TOP must be turned up for the 1st and 2nd compression rings.

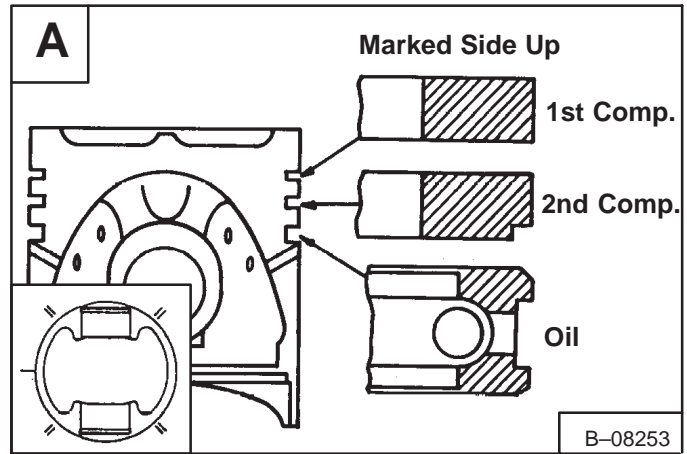
**Installation**

Using a ring compressor tool, compress the rings on the piston. Make sure the *mark* is to the front of the engine and install the piston in the block [B].

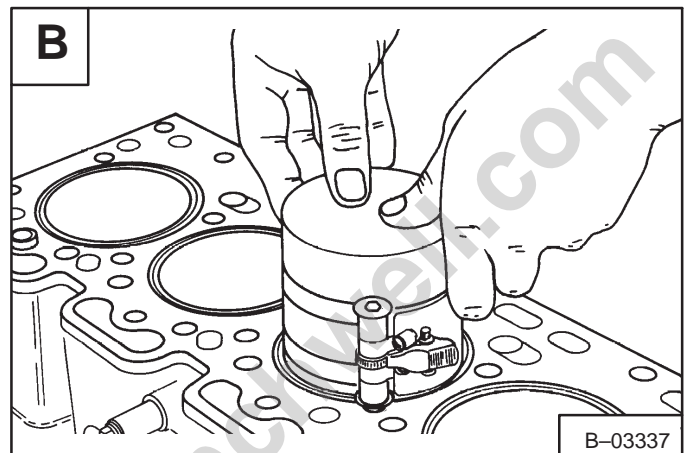

Put oil on the bearings. Install the bearing cap [C].

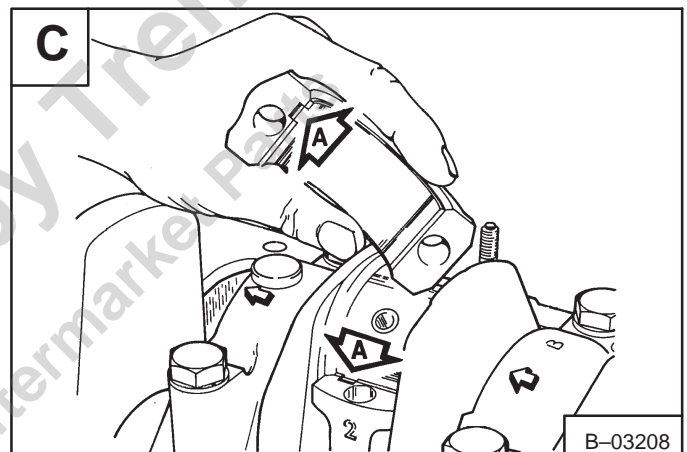

Tighten the nuts to 58–65 ft.-lbs. (78–88 Nm) torque [D].

Rotate the crankshaft to put the other pair of crank pins at bottom dead center. Repeat the procedure and install the other pair of pistons.

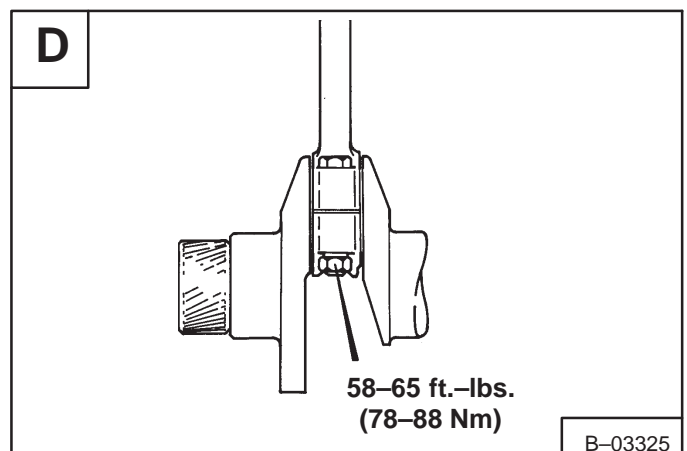

CYLINDER LINERS

Checking The Cylinder Bore

The tools listed will be needed to do the following procedure:

MEL1180 – Puller Set

MEL1261 – Cylinder Liner Remover Ankle

Check the cylinder bore with an inside micrometer. The checks must be made at parallel and right angles to the center line of the bore **[A]**.

Measuring point is done approximately 0.75 inch (20 mm) below the top of the cylinder bore.

Standard – 3.6622–3.6638 inch (93,021–93,060 mm)

Limit – 3.6653 inch (93,10 mm)

Removal

Remove all the parts from the engine.

Using a cylinder liner tool, remove the cylinder liner from the engine block **[B]**.

There is only one size liner available.

Installation

The tools listed will be needed to do the following procedure:

MEL1262 – Cylinder Liner Installer

Clean the bore and remove any metal burrs.

Clean the grease from the cylinder liner and dry it.

Use dry ice to cool the cylinder liner, so it will install easier and smoothly into the engine block.

Using the correct tool, install the cylinder liner **[C]**.

First apply a load of 1103 lbs. (500 kg) using a hydraulic press.

NOTE: Do Not use a hammer to install the cylinder liners.

Then, apply a final load of 5513 lbs. (2500 kg). Push the liner in until 0–0.0039 inch (0–0,10 mm) of the liner is above the block face **[D]**.

NOTE: The liners are chrome plated and must not be honed after installation.

Measure the inside diameter of the liner and select the correct size piston for the liner.

Minimum Diameter

Piston Grade A 3.6622–3.6630 inch
(93,021–93,040 mm)

Piston Grade C 3.6630–3.6638 inch
(93,041–93,060 mm)

Refer to parts fiche when ordering pistons, piston rods and cylinder liners.

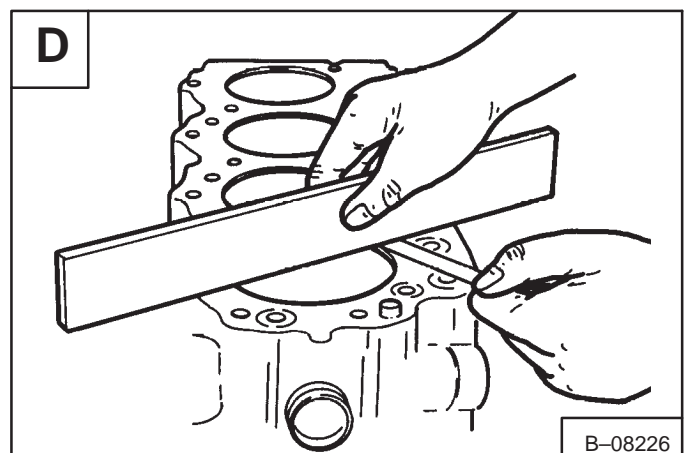
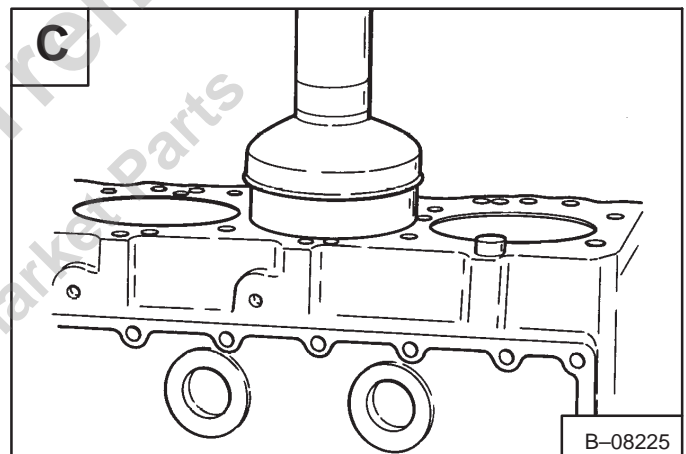
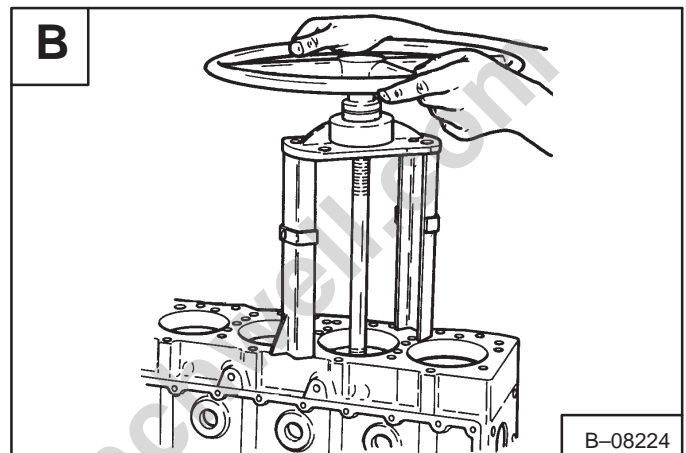
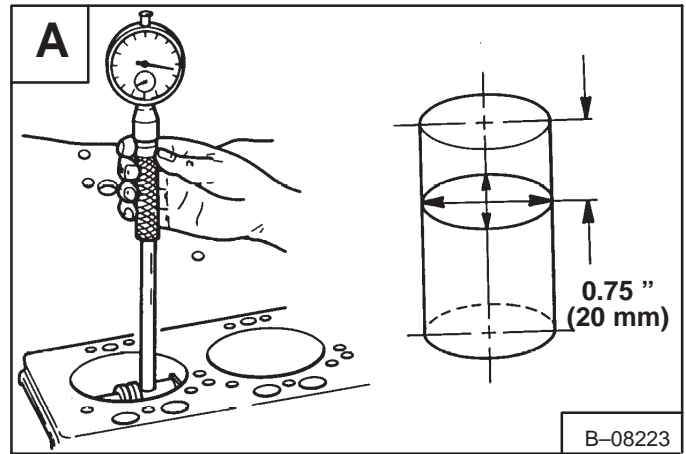

MAIN BEARINGS

Description

The crankshaft has five main bearings. The end play is controlled by a thrust washer on both sides of the center main bearing.

Each main bearing cap has an identification mark in relation to the engine block **[A]**.

The position of each cap can not be changed from the original location.

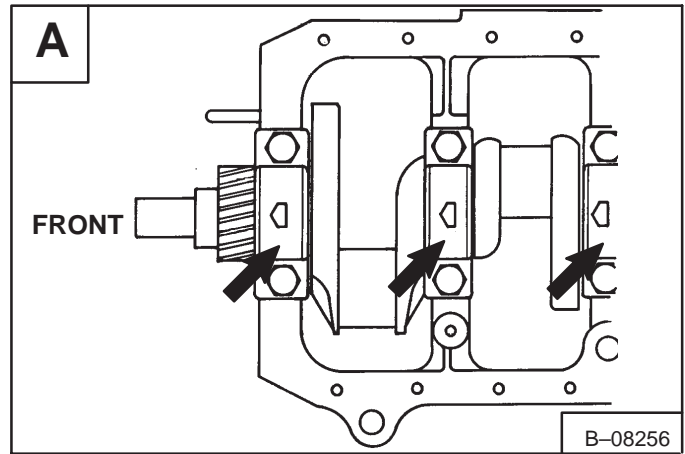

Removal

Remove the oil pan. (See Page 7-81.)

Remove the oil pump. (See Page 7-84.)

Remove the bolts from the main bearing caps.

Remove the main bearing cap and remove the bearing from the cap half.

Remove the top half of the bearing by pushing on one side of the bearing half and rotating the crankshaft **[B]**.

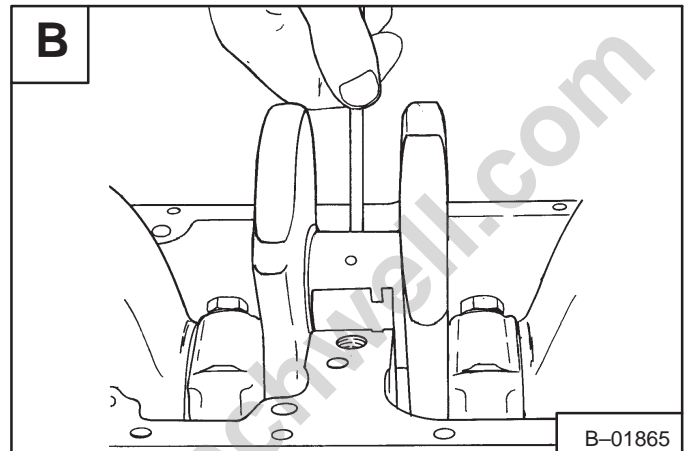

On the center main bearing, remove the cap.

Remove the top half of the bearing and thrust washers by pushing on one side of the bearing and rotating the crankshaft **[C]**.

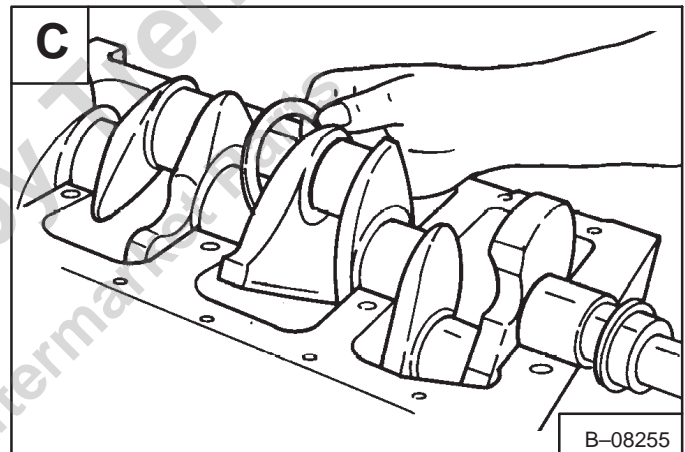

MAIN BEARINGS (Cont'd)**Installation**

Check the bearing spread as listed [A].

Limit – 2.93 inch (74,5 mm)

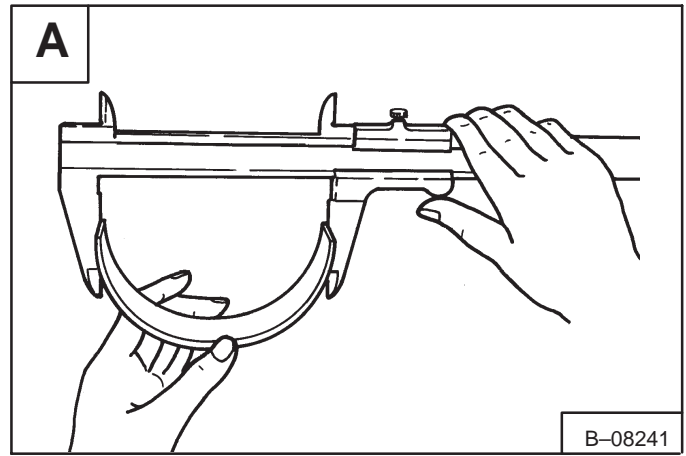

Check to see if the bearing has enough tension, so that finger pressure is needed to fit the bearing into the cap [B].

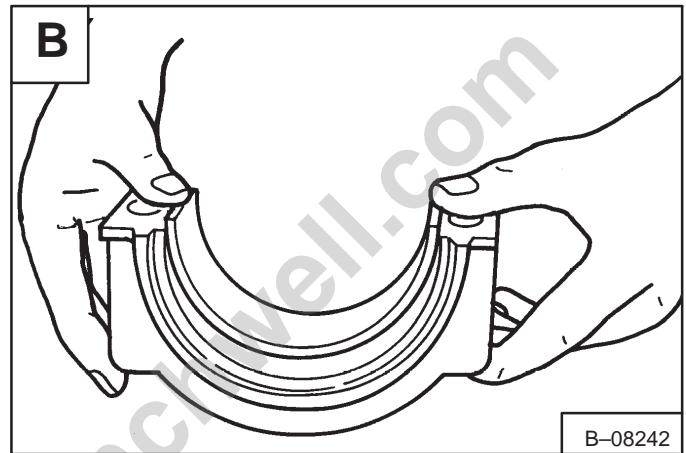

Check the crankshaft journals before installing the main bearings. (See Page 7-68.)

Make sure to position the bearing halves in their correct locations [C].

Lubricate the new bearings. Install them by putting the end without the tab into the block and rotating the crankshaft until the tab is on its seat.

Install the other bearing half in the bearing cap. Lubricate the bearing and install the cap on the engine block.

Lubricate the bolts, install them finger tight only.

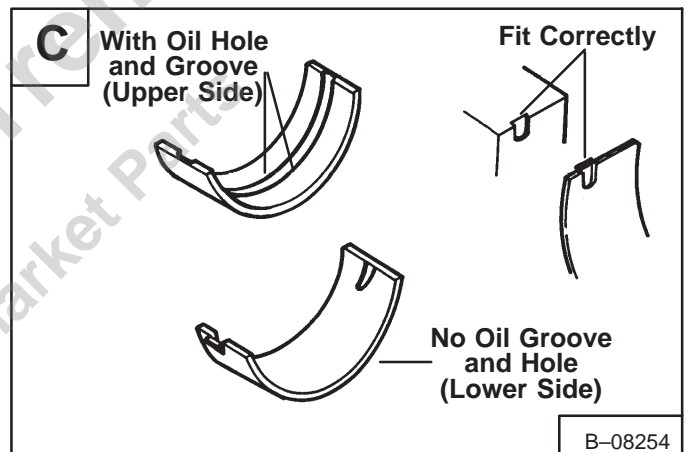

Install the center main bearing and thrust washers [D].

The thrust washer must be installed so that their oil grooves are turned to the rotating face of the crankshaft.

Repeat the procedure until all the main bearings and caps are installed.

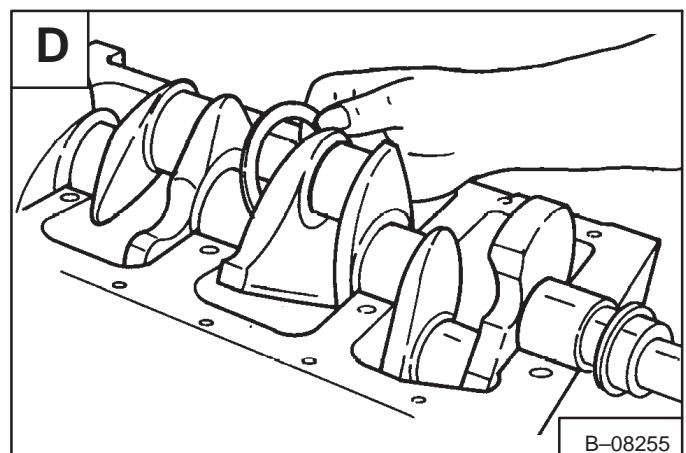

MAIN BEARINGS (Cont'd)

Installation (Cont'd)

Tighten the crankshaft bearing cap bolts in the correct sequence **[A]**.

Torque – 116–130 ft.-lbs. (157–176 Nm).

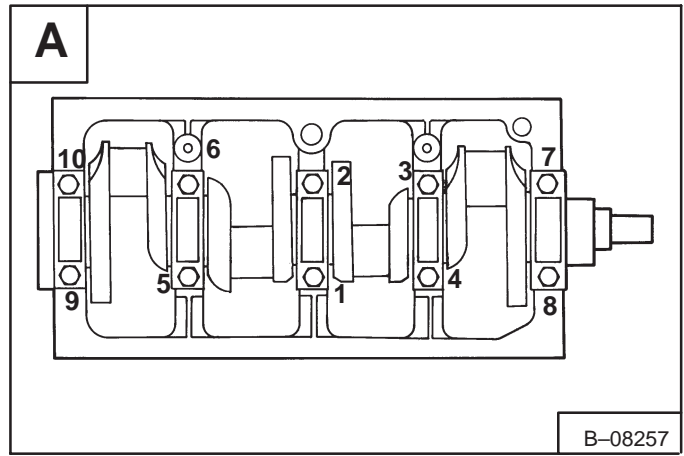

B-08257

Crankshaft End Play

The end play can be checked by either a feeler gauge **[B]** or dial indicator **[C]**.

Standard End Play 0.004 inch (0,10 mm)
 Limit 0.012 inch (0,30 mm)

The fitting of oversize thrust washer can be used to correct the end play if it is over the specifications.

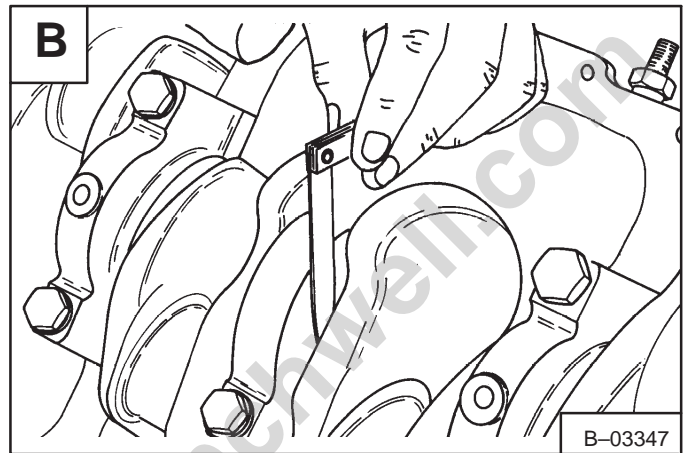

B-03347

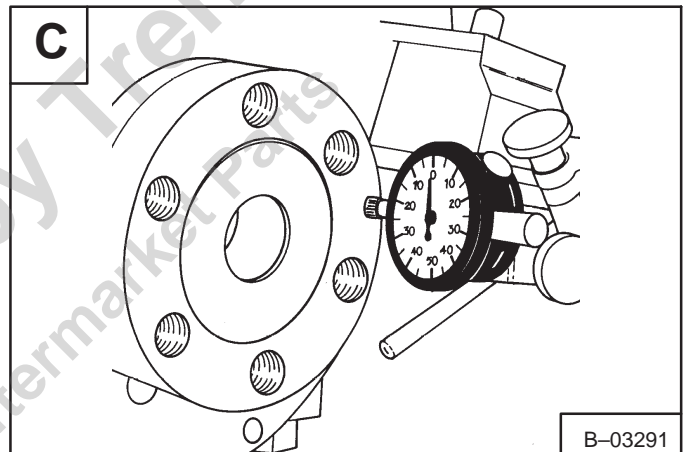

B-03291

Provided for Free by TrendyPatents.com
 Shop Aftermarket Parts

CRANKSHAFT

Removal And Installation

Remove the oil pan. (See Page 7-81.)

Remove the oil pump. (See Page 7-82.)

Remove the crankshaft pulley, timing gearcase cover and timing gears. (See Page 7-71.)

Remove the flywheel.

Remove the connecting rod cap. (See Page 7-57.)

Remove the main bearing cap. (See Page 7-64.)

Lift the crankshaft out of the engine block.

Checking Tuffriding (Soft Nitriding) Coating

Clean the crankshaft thoroughly using an organic solvent. Make sure there is no oil or grease in the area to be tested.

Using a glass rod, put a drop of cupric ammonium chloride 5/10% solution at the test location **[A]**.

If no change takes place after an interval of 30-40 seconds, the crankshaft can be re-used if within specifications.

Replace the crankshaft, if within the 30-40 seconds, the original color of the solution (light blue in color) becomes transparent where the test solution was dropped and will discolor to a copper color.

Immediately after the test is completed, wipe off the area with a cloth and thoroughly rinse with water.

NOTE: Since the crankshaft is tuffride coated it cannot be reground.

Checking The Crankshaft

Check the crankshaft connecting rod journals **[B]**.

Standard – 2.0833–2.0839 inch (52,915–52,930 mm)
Limit – 2.0829 inch (52,906 mm)

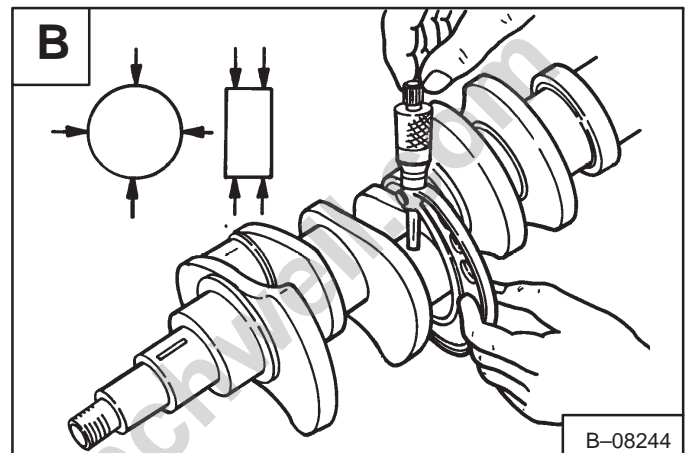
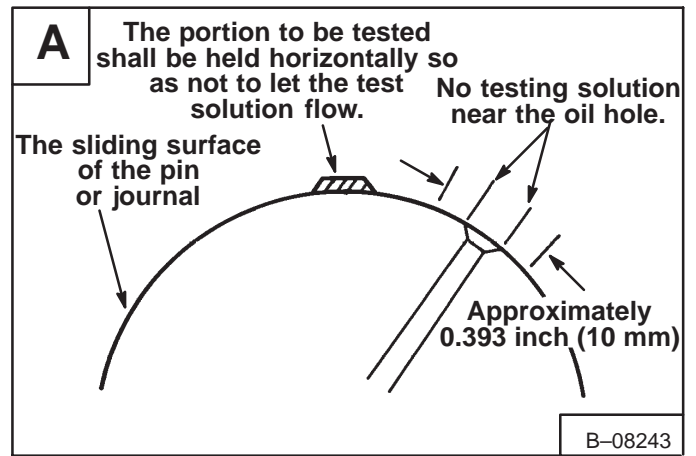

CRANKSHAFT (Cont'd)**Checking The Crankshaft (Cont'd)**

Check the crankshaft main bearing journals **[A]**.

Standard – 2.7526–2.7532 inch (69,917–69,932 mm)
Limit – 2.7524 inch (69,910)

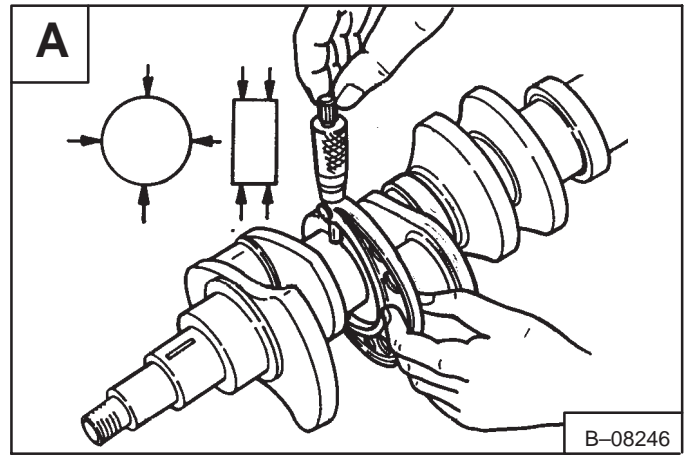

Check the clearance between connecting rod bearing and crankshaft journal **[B]**.

Install the bearing and cap and tighten nuts to 58–65 ft.-lbs. (79–88 Nm) torque. Put oil on the bearing and measure.

Nominal Diameter – 2.09 inch (53,0 mm)

Clearance between journal and bearing:

Standard – 0.0011–0.0026 inch (0,029–0,066 mm)
Limit – 0.004 inch (0,10 mm)

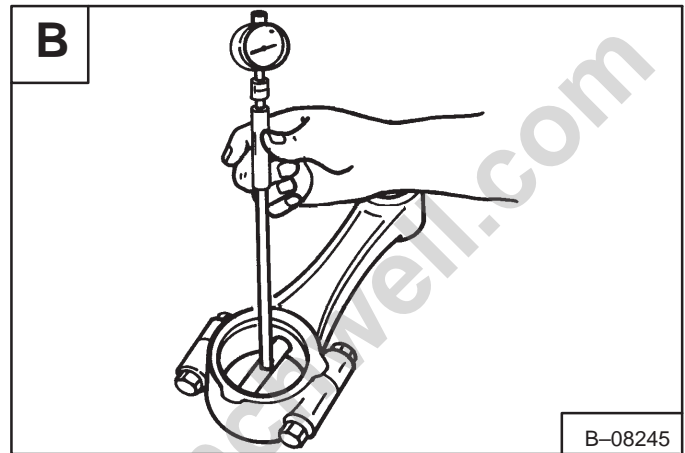

Check the clearance between main bearings and crankshaft journals **[C]**.

Install the main bearing and caps and tighten the bolts to 116–130 ft.-lbs. (157–176 Nm) torque. Put oil on the main bearings and measure.

Nominal Diameter – 2.76 inch (70,0 mm)

Clearance between the journal and bearing:

Standard – 0.0014–0.0031 inch (0,035–0,080 mm)
Limit – 0.0043 inch (0,11 mm)

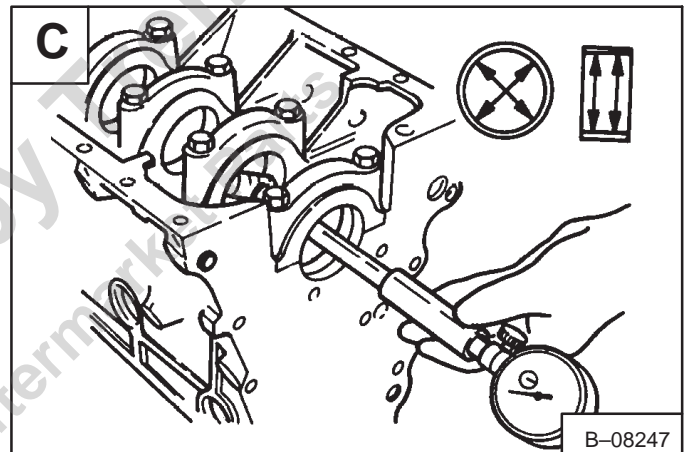

Check the crankshaft run-out **[D]**.

Standard – 0.0019 inch (0,05 mm) or less
Limit – 0.003 inch (0,08 mm)

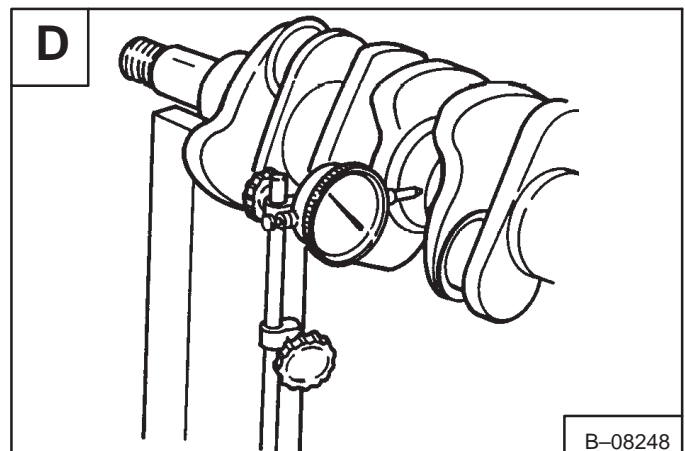

CRANKSHAFT GEAR

Removal And Installation

The tools listed will be needed to do the following procedure:

MEL1263 – Crankshaft Gear Installer
MEL1264 – Crankshaft Rear Oil Seal

Use a puller to remove the gear **[A]**.

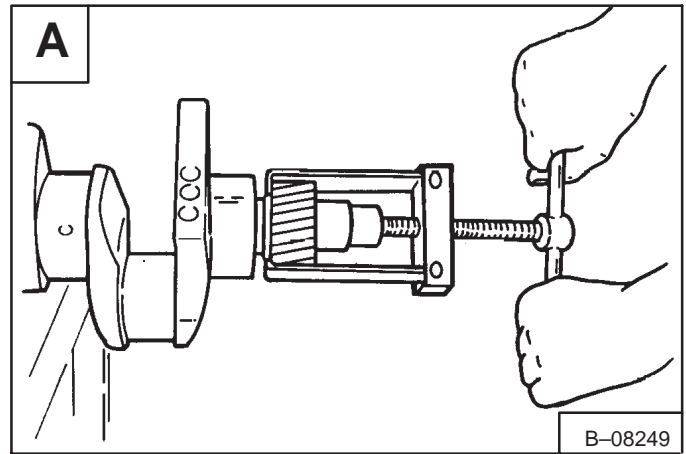

Use the correct size driver tool to install the gear **[B]**.

Clean the crankshaft and check that all the oil passages are clean and open.

Clean the engine block, lubricate and install the upper halves of the main bearings.

Put the crankshaft carefully in position.

Install the main bearing caps and bolts. (See Page 7-64.)

Check the crankshaft so that it rotates freely. Check the end play. (See Page 7-66.)

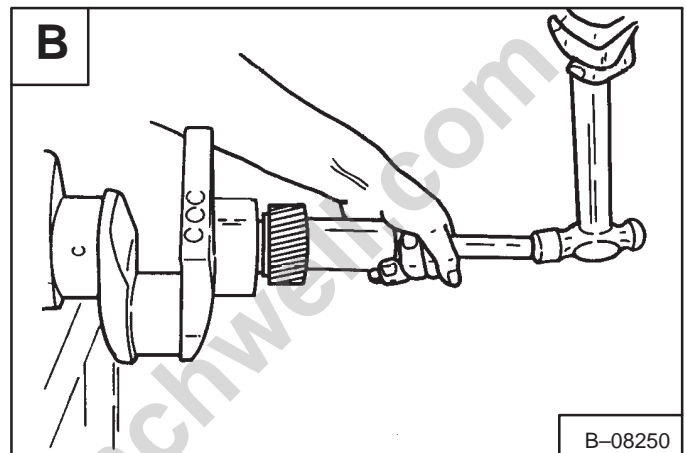

Install a new rear oil seal **[C]**. Using the correct size driver tool.

Lubricate the connecting rod bearings. Install the bearings and rod caps. (See Page 7-62.)

Install the oil pump. (See Page 7-82.)

Install the oil pan. (See Page 7-81.)

Install the timing gears, timing gearcase cover and new front seal. (See Page 7-81.)

Install the flywheel. (See Page 7-37.)

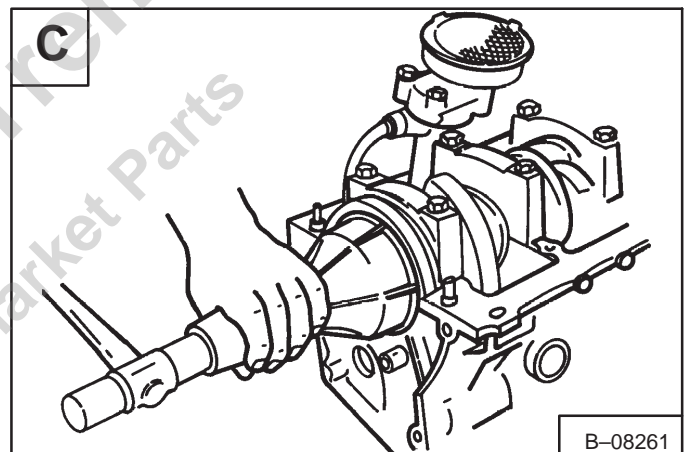

TIMING GEARCASE COVER SEAL**Removal And Installation**

The tool listed will be needed to do the following procedure:

MEL1265 – Crankshaft Front Oil Seal Installer

Remove the alternator and belt. (See Page 6-1.)

Remove the bolt at the crankshaft pulley **[A]**.

Installation: Tighten the bolt to 123–152 ft.-lbs. (167–206 Nm) torque.

Install a standard puller and remove the crankshaft pulley **[B]**.

Use a screwdriver and pry the front seal out of the timing case cover **[C]**.

Use the seal installation tool and install the new seal **[D]**.

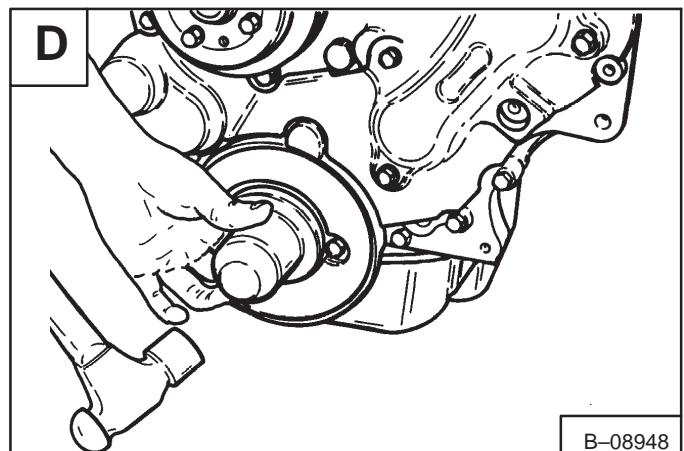
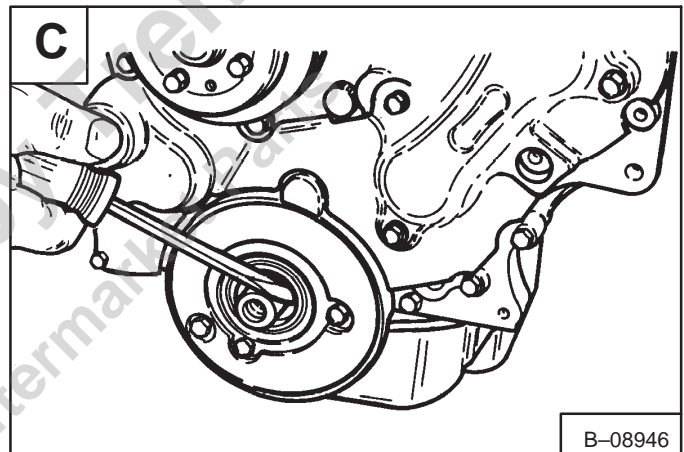
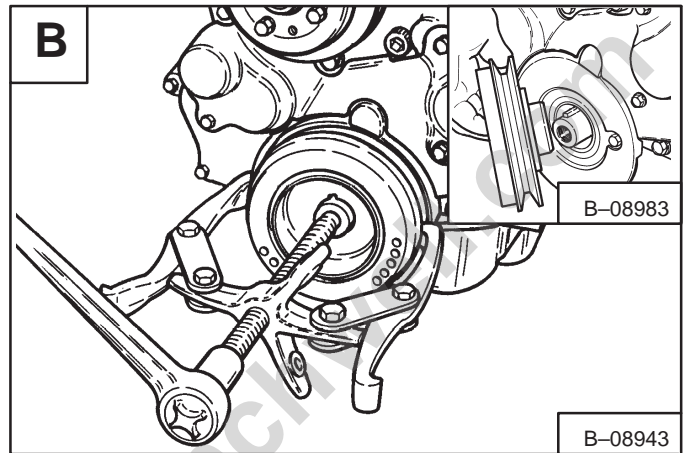
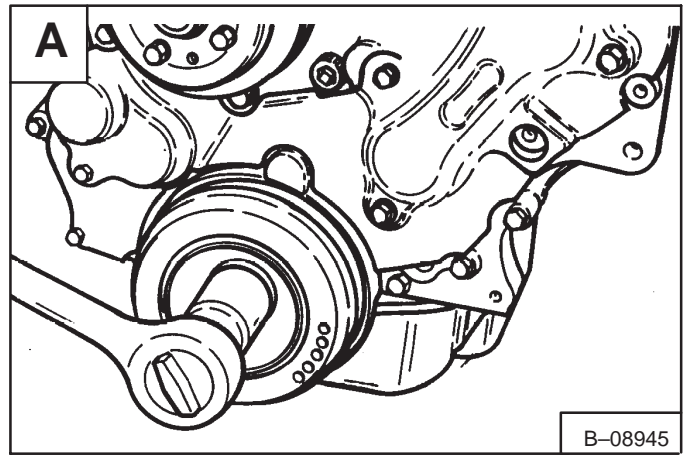

TIMING GEARCASE COVER**Removal And Installation**

Remove the alternator and belt. (See Page 6-1.)

Remove the bolt at the crankshaft pulley **[A]**.

Installation: Tighten the bolt to 123–152 ft.-lbs. (167–206 Nm) torque.

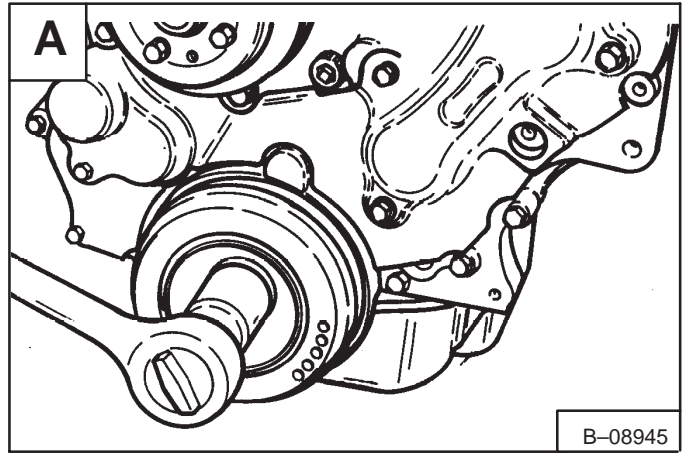

Use a puller to remove the crankshaft pulley **[B]**.

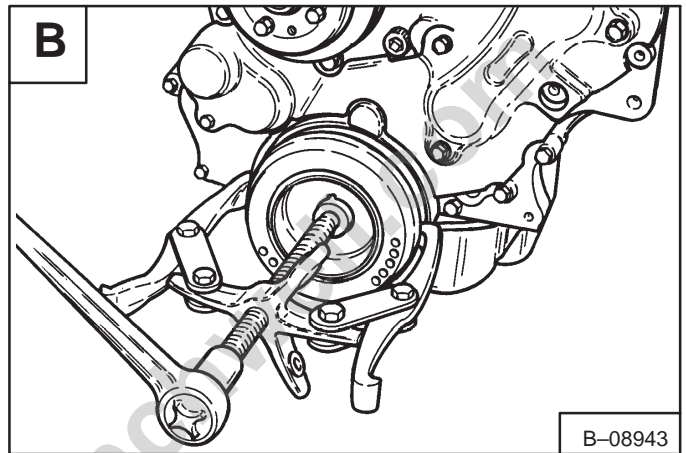

Remove the bolts which fasten the noise dampening shield to the timing case cover **[C]**.

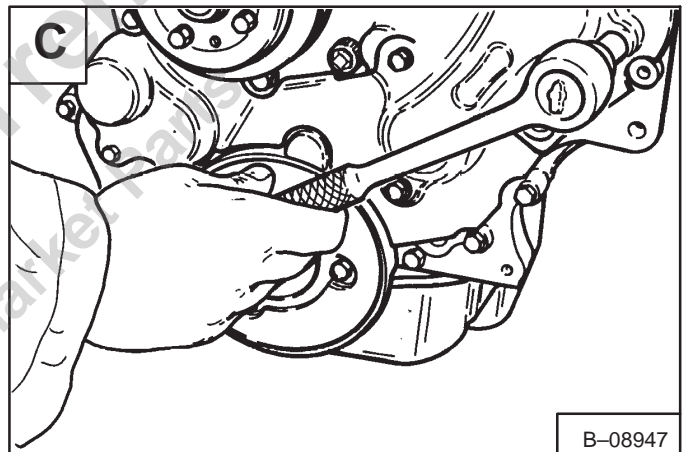

Remove the noise dampening shield **[D]**.

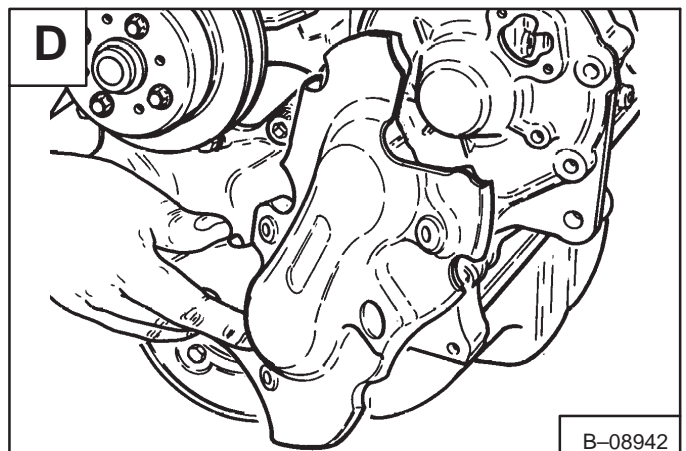

TIMING GEARCASE COVER (Cont'd)**Removal And Installation (Cont'd)**

Remove the bolts from the timing gearcase cover [A].

Installation: Tighten the bolts to 10 ft.-lbs. (14 Nm) torque.

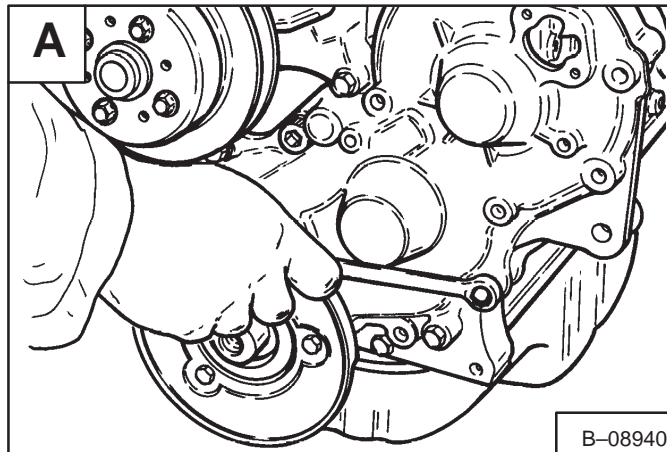

Use an allen wrench to remove the allen head bolt from the cover [B].

Installation: Tighten the bolt to 11-17 ft.-lbs. (15-23 Nm) torque.

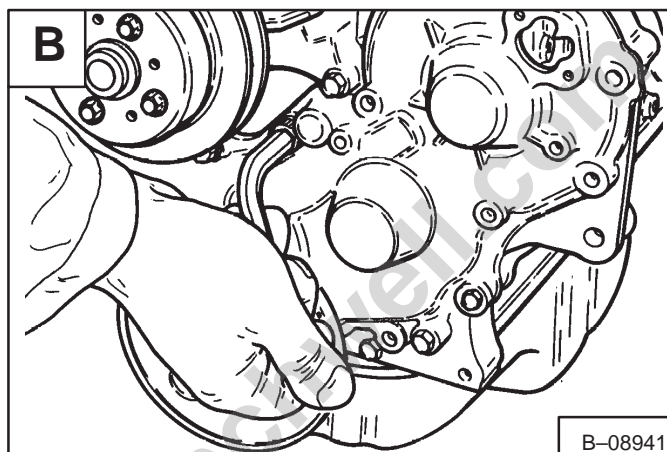

Remove the timing gearcase cover [C].

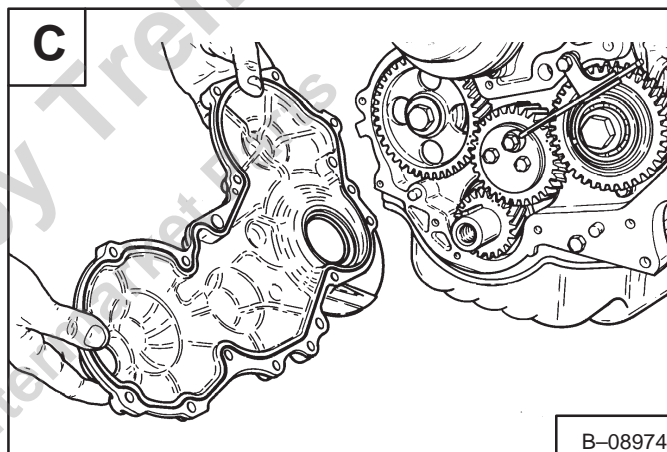

Installation: Put the O-ring gasket in the groove and hold it in position using Form-A-Gasket so it will not fall out when installing the cover [D].

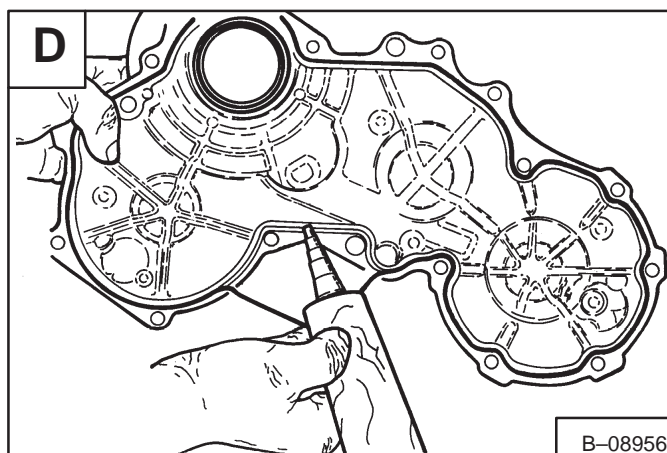

IDLER GEAR AND HUB

Removal

Remove the timing gearcase cover. (See Page 7–71.)

Remove the bolts at the tube for gear lubrication [A].

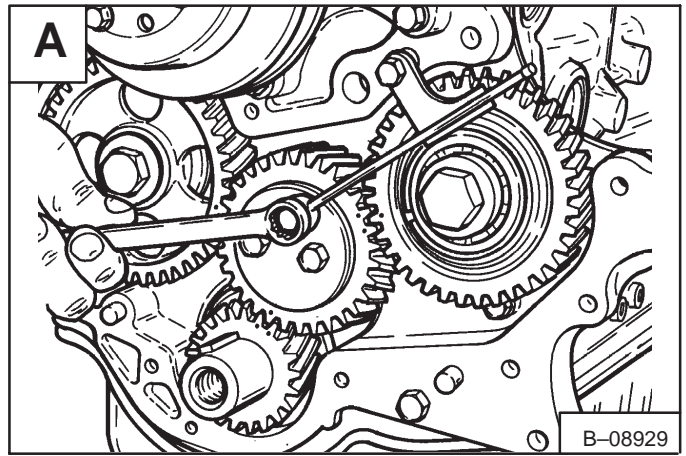

Remove the tube [B].

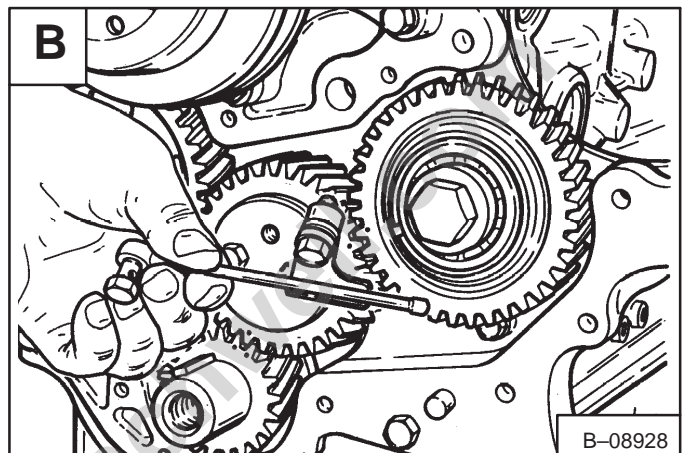

Remove the bolts at the idler gear [C].

Installation: Tighten the bolts to 10–12 ft.-lbs. (14–16 Nm) torque.

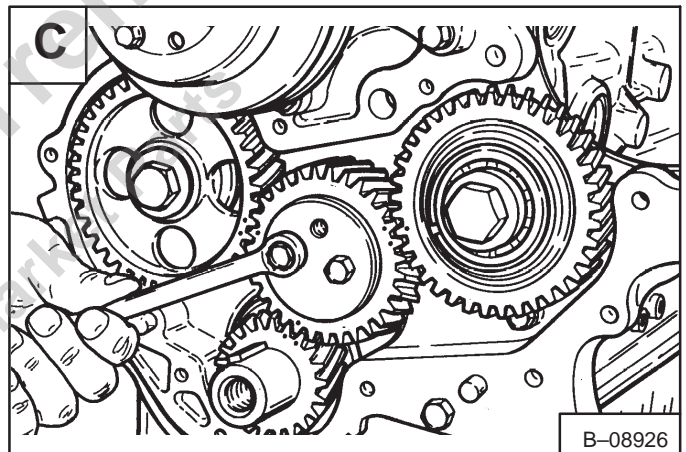

Remove the idler gear and hub [D].

Checking

Check the idler gear hub.

Standard – 1.7695–1.7707 inch (44,945–44,975 mm)
Limit – 1.7656 inch (44,845 mm)

Check the clearance between the idler gear and hub.

Limit – 0.0079 inch (0,20 mm)

Check the end play at the gear and hub.

Standard – 0.003 inch (0,07 mm)
Limit – 0.008 inch (0,20 mm)

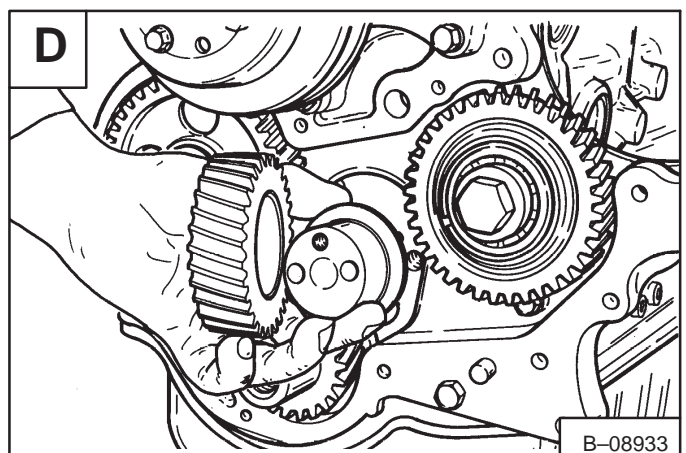

IDLER GEAR AND HUB (Cont'd)

Installation

Install the idler gear on the hub.

Make sure the timing marks are in alignment with the crankshaft, camshaft and fuel injection pump idler gears [A].

Check the backlash between the gears. The correct backlash is 0.003 inch (0,076 mm).

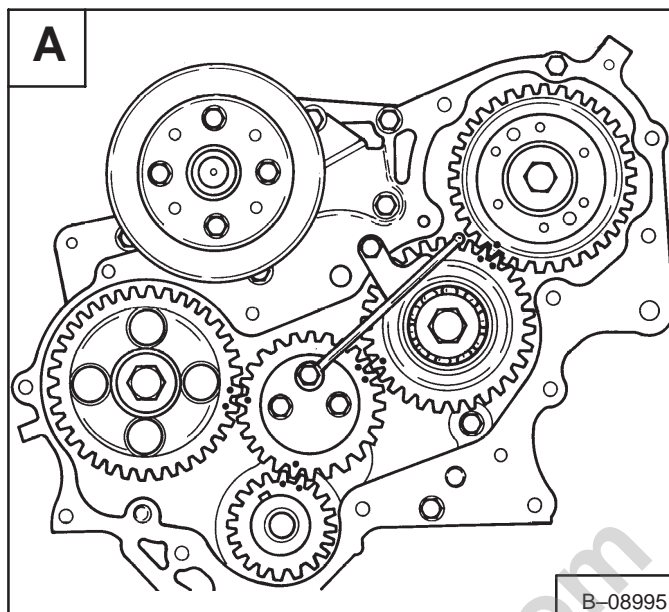

Provided for Free by Trenchwell.com
Shop Aftermarket Parts

FUEL INJECTION PUMP IDLER GEAR**Removal And Installation**

Remove the timing gearcase cover. (See Page 7-71.)

Remove the idler gear. (See Page 7-73.)

Remove the bolt at the fuel injection pump idler gear **[A]**.

Installation: Tighten the bolt to 72–87 ft.-lbs. (98–118 Nm) torque.

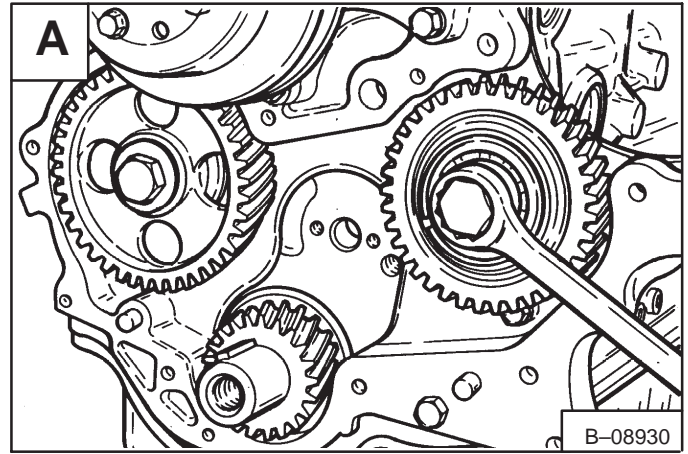

Remove the idler gear and bearing **[B]**.

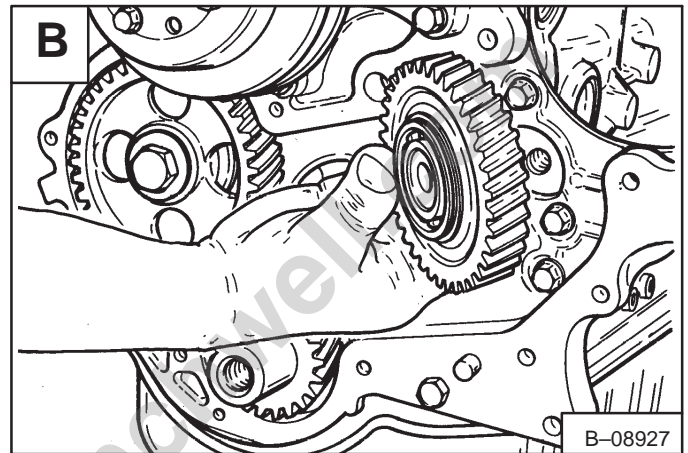

If the bearing needs replacement, remove the snap ring at the bearing **[C]**.

Use a press to remove and install the new bearing.

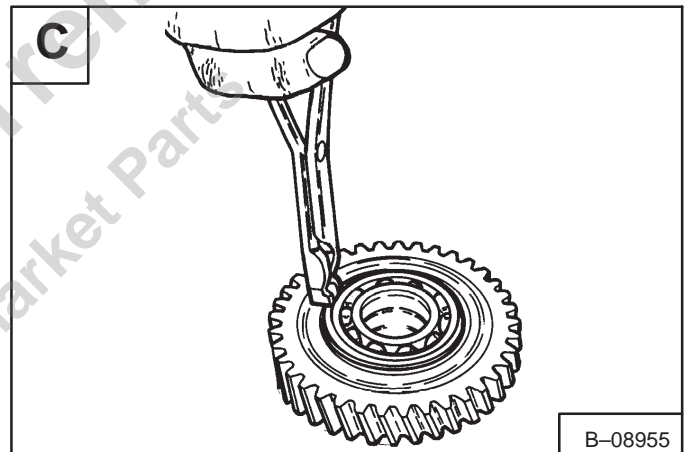
**Bearing Installation**

When installing the new bearing, make sure the projection and height is correct **[D]**.

Projection – 0.016–0.024 inch (0,40–0,60 mm)

Height – 0.933–0.945 inch (23,7–24,0 mm)

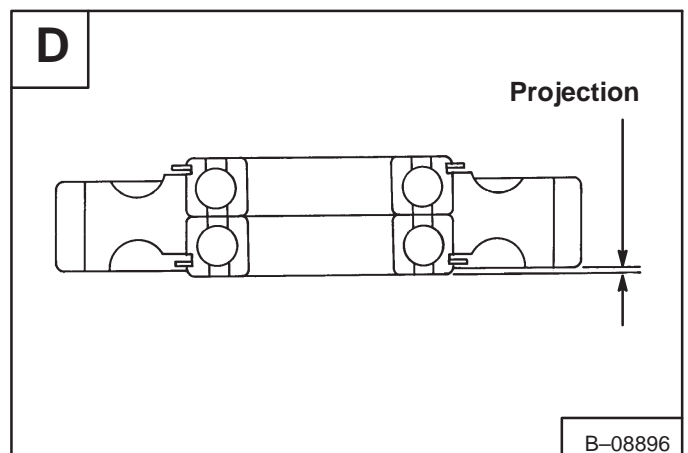

CAMSHAFT GEAR**Removal And Installation**

Remove the timing gearcase cover. (See Page 7-71.)

Remove the idler gear. (See Page 7-73.)

Remove the bolt at the camshaft gear **[A]**.

Installation: Tighten the bolt to 72–87 ft.-lbs. (98–118 Nm) torque.

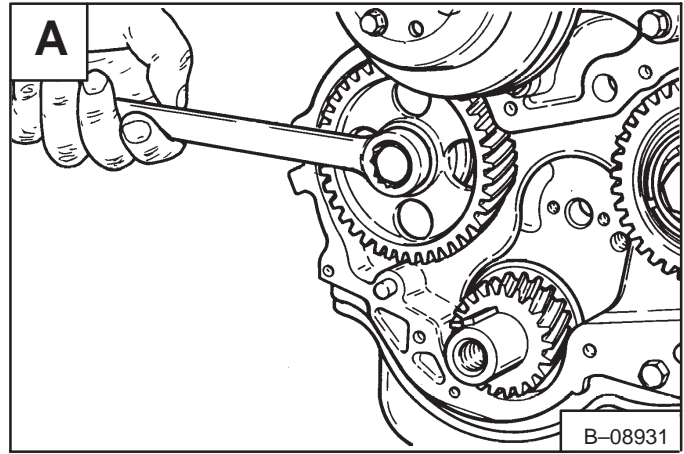

Install the puller and remove the gear **[B]**.

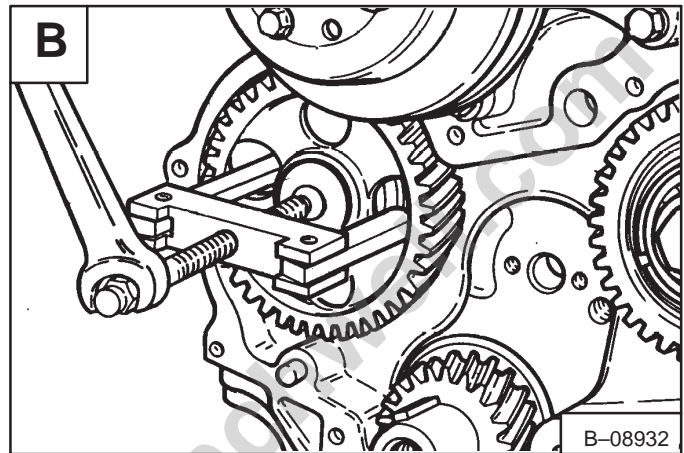

Remove the bolts at the retainer plate **[C]**.

Installation: Tighten the bolts to 11–17 ft.-lbs. (15–23 Nm) torque.

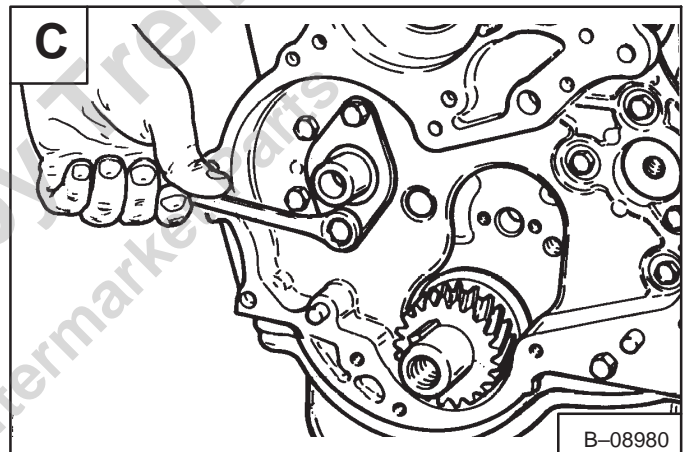

Remove the retainer plate **[D]**.

Installation: Check the camshaft end play.

Standard – 0.002–0.0045 inch (0,05–0,114 mm)
Limit – 0.0079 inch (0,20 mm)

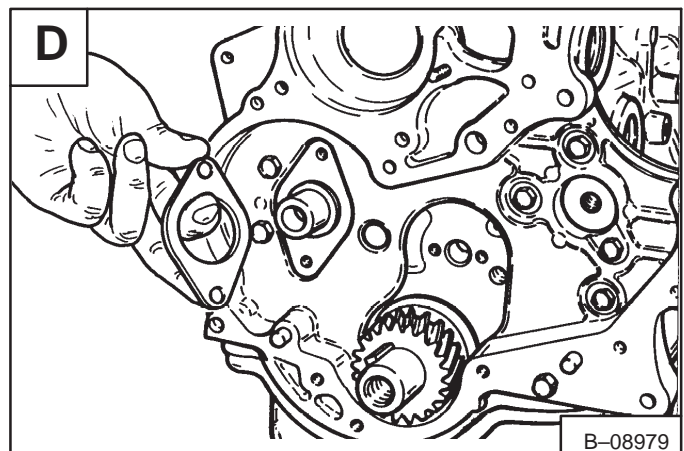

TIMING GEARCASE

Removal And Installation

Remove the timing gearcase cover. (See Page 7-71.)

Remove the idler gear. (See Page 7-73.)

Remove the fuel injection pump. (See Page 7-42.)

Remove the fuel injection pump idler gear. (See Page 7-75.)

Remove the camshaft gear. (See Page 7-76.)

Remove the water pump. (See Page 7-85.)

Remove the oil pan. (See Page 7-81.)

Remove the bolts at the timing case [A].

Installation: Tighten the bolts to 11-17 ft.-lbs. (15-23 Nm) torque.

Remove the timing case [B].

Installation: After the timing case cover is installed with the new gasket, cut the excess gasket at the engine block [C].

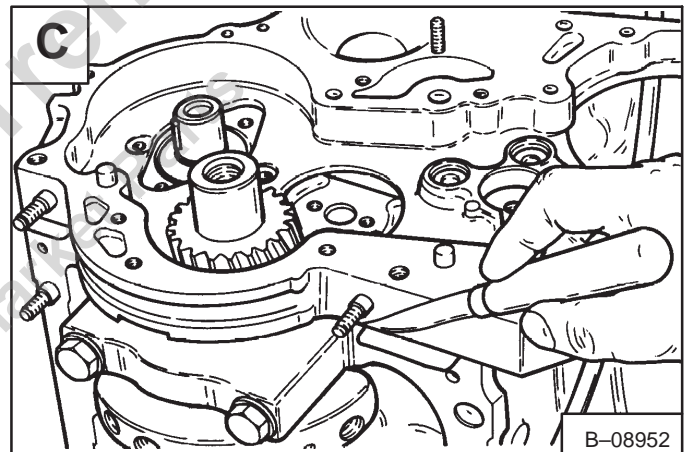
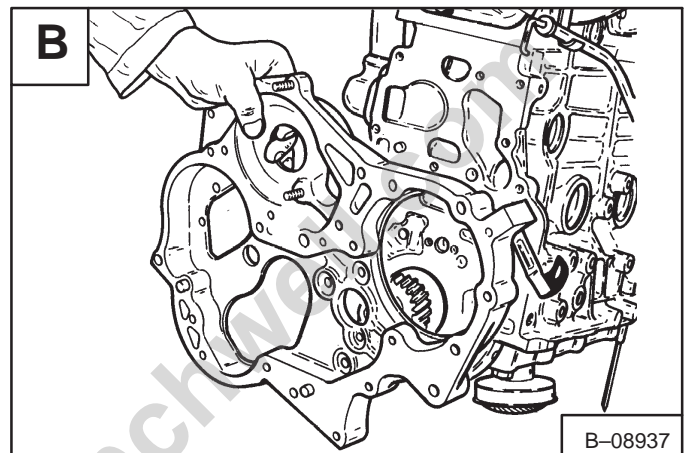
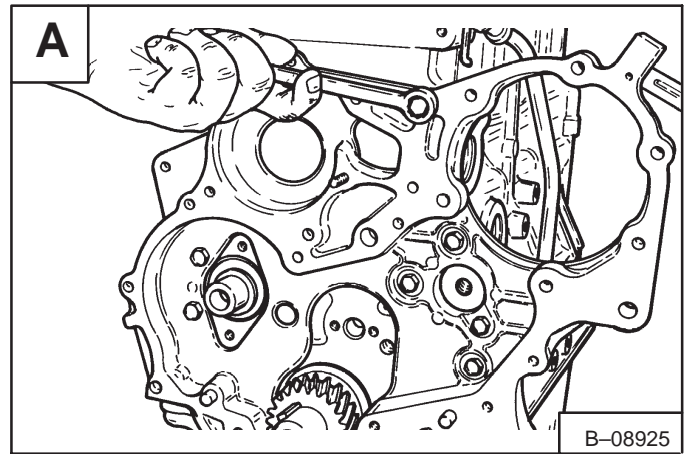

CAMSHAFT**Removal And Installation**

Remove the rocker arm cover, rocker arm assembly and the push rods. (See Page 7-56.)

Remove the timing gearcase cover. (See Page 7-71.)

Remove the camshaft gear. (See Page 7-76.)

Remove the oil pan and oil pump. (See Pages 7-81 & 7-82.)

Remove the camshaft from the engine.

Checking

Check the camshaft journals **[A]**.

Standard – 1.9662–1.9675 inch (49,945–49,975 mm)

Limit – 1.9528 inch (49,60 mm)

Check the bearing inside diameter **[B]**.

Standard – 1.9685–1.9697 inch (50,0–50,03 mm)

Clearance between camshaft journal and bearing:

Standard – 0.002 inch. (0,05 mm)

Limit – 0.0047 inch (0,12 mm)

Check camshaft run-out **[C]**.

Limit – 0.0039 inch (0,10 mm)

Check cam lobe height **[D]**.

Standard – 1.654 inch (42,02 mm)

Limit – 1.640 inch (41,65 mm)

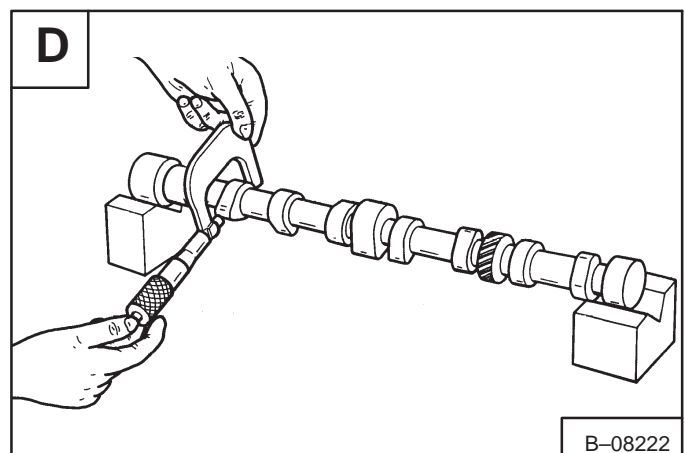
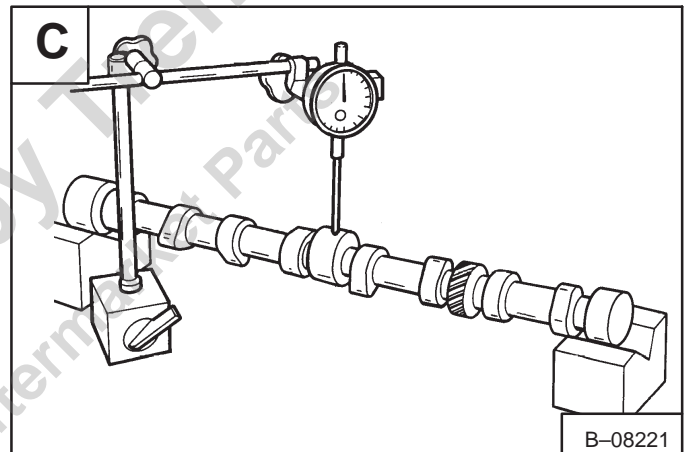
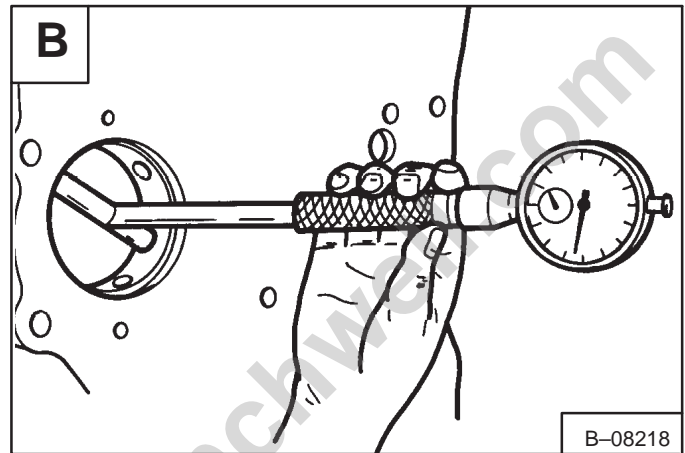
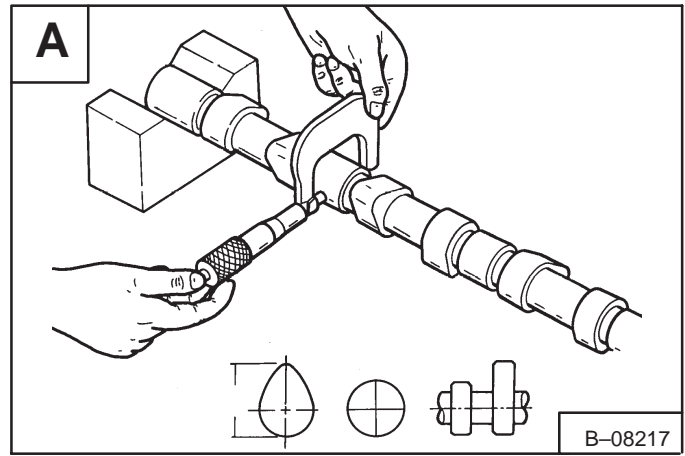

CAMSHAFT (Cont'd)

Camshaft Bearings

The tools listed will be needed to do the following procedure:

MEL1260 – Camshaft Bearing Remover/Installer

Use the correct tool to remove the bearings [A].

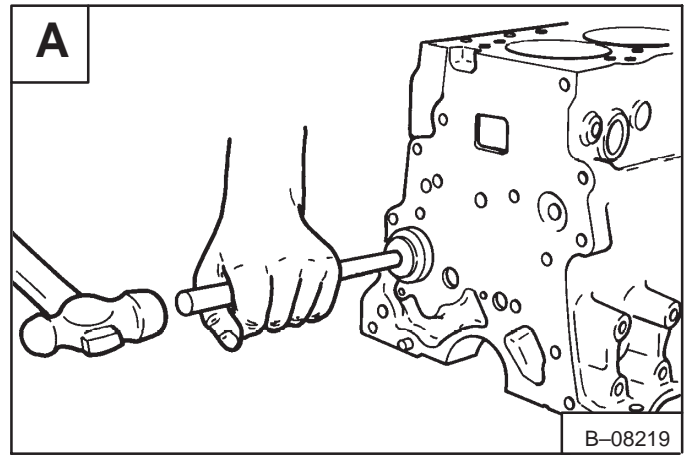

When installing the new bearings, make sure to align the oil hole in the bearing with the hole in the engine block (Item 1) [B].

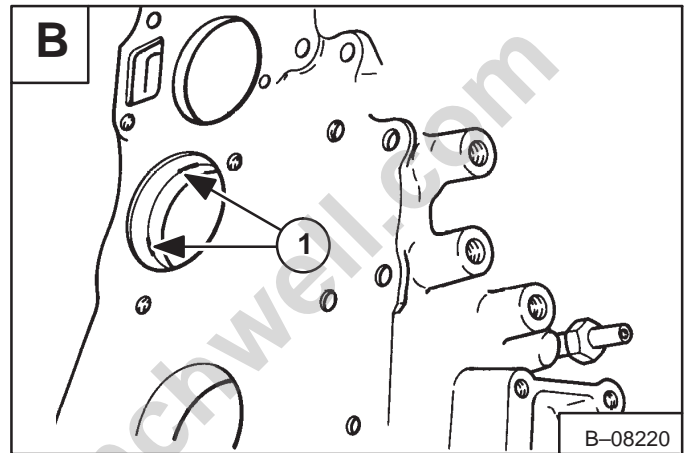

Tappets

Remove the tappets from the engine block. Mark the cylinder number on each tappet after removal [C].

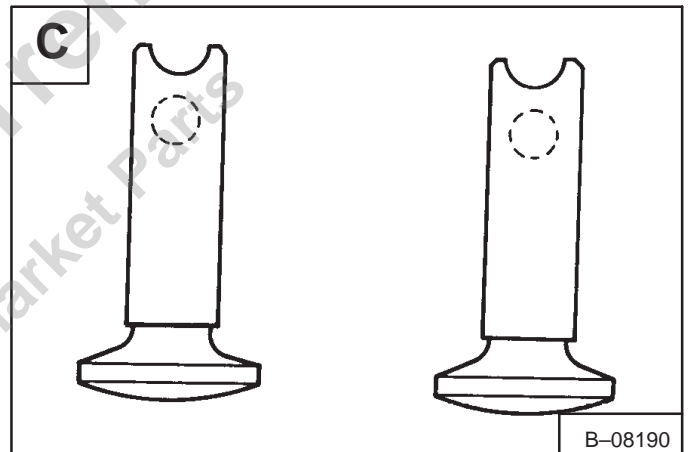

Inspect the tappets for wear, damage or abnormal conditions [D].

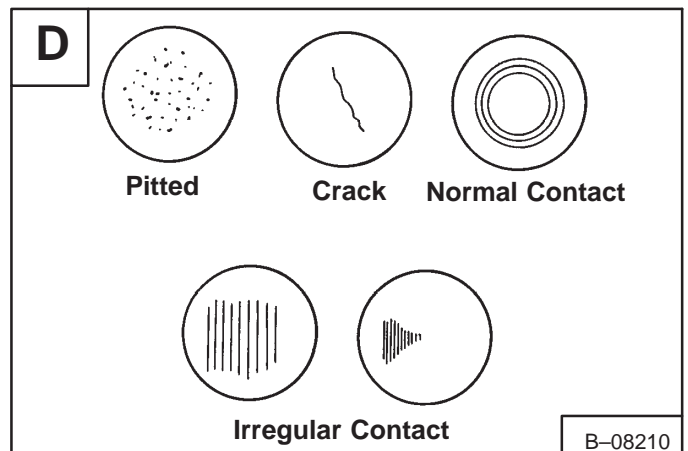

CAMSHAFT (Cont'd)**Tappets (Cont'd)**

Check the diameter of the tappets **[A]**.

Standard – 0.511–0.5114 inch (12,98–12,99 mm)
Limit – 0.510 inch (12,95 mm)

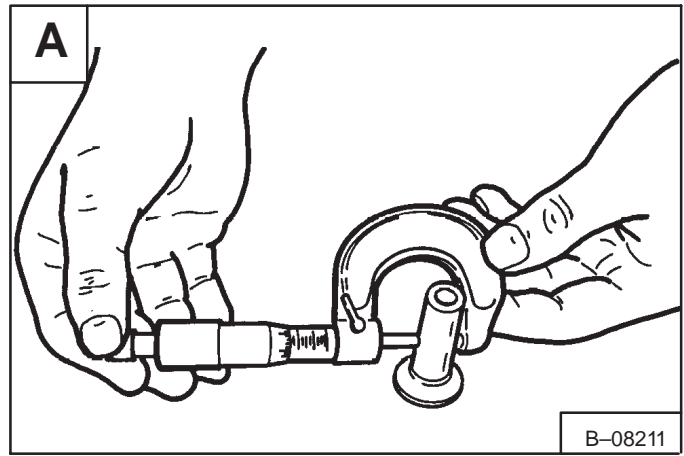

Clearance between tappet and engine block bore as listed **[B]**.

Standard – 0.0012 inch (0,03 mm)
Limit – 0.0039 inch (0,09 mm)

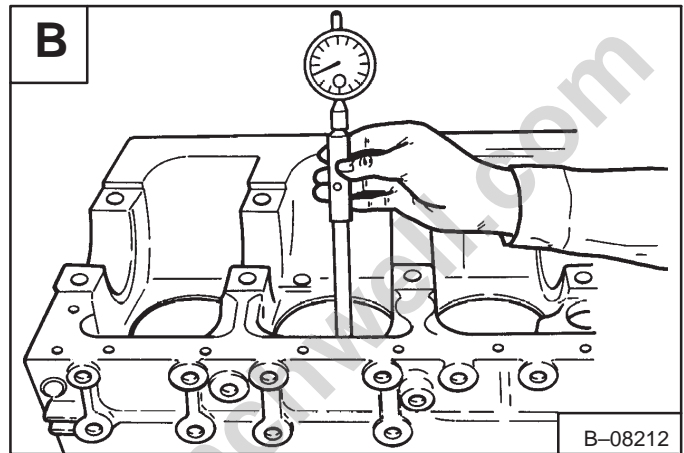
**Tappet Installation**

Lubricate the tappets before installation.

Lubricate the camshaft bearings and journals. Install the camshaft, carefully not to damage the bearings.

Install the camshaft gear. (See Page 7–76.)

Check the camshaft end play using a feeler gauge **[C]**.

Standard – 0.0002–0.0045 inch (0,05–0,114 mm)
Limit – 0.0079 inch (0,20 mm)

After the rocker arm assembly is installed, make sure to set the valve clearance. (See Page 7–41.)

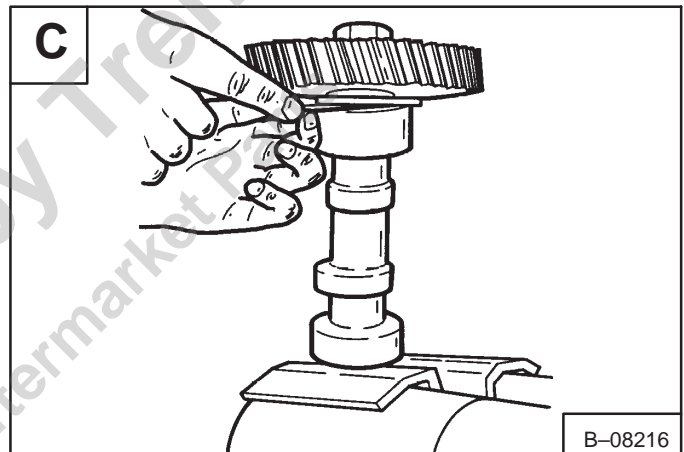

OIL PAN**Removal**

Remove the oil drain plug and remove the oil.

Remove the fastening bolts and nuts from the oil pan [A].

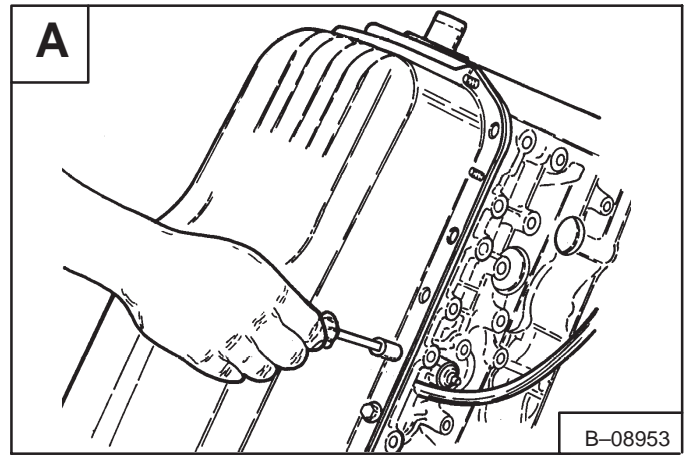
**Installation**

Clean the surface on the oil pan and engine block.

Put Three Bond (TB-1207B) at the front and rear main bearing caps (Item 1) [B] & [C].

Put liquid gasket on the oil pan surface area of the engine block.

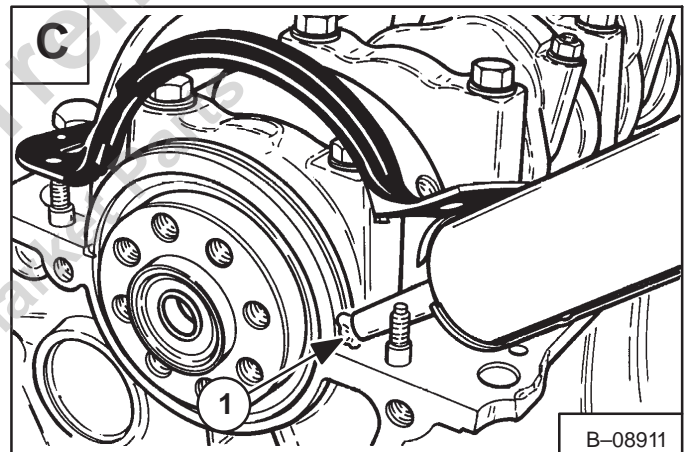
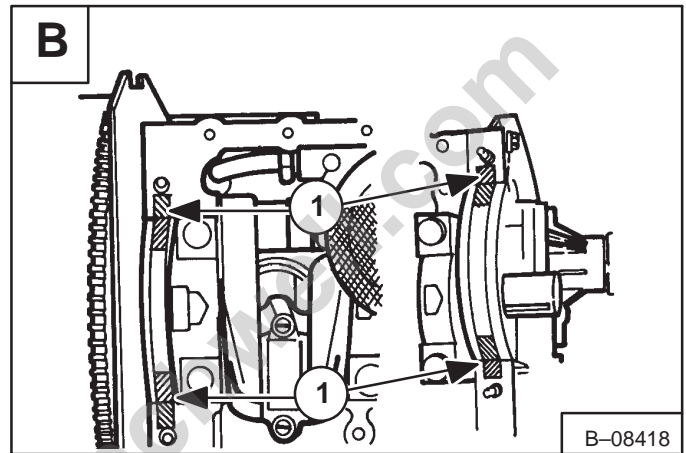

Install the oil pan. Install and tighten the bolts in the sequence shown [D].

Tighten the bolts and nuts to 13–18 ft.-lbs. (19–26 Nm) torque.

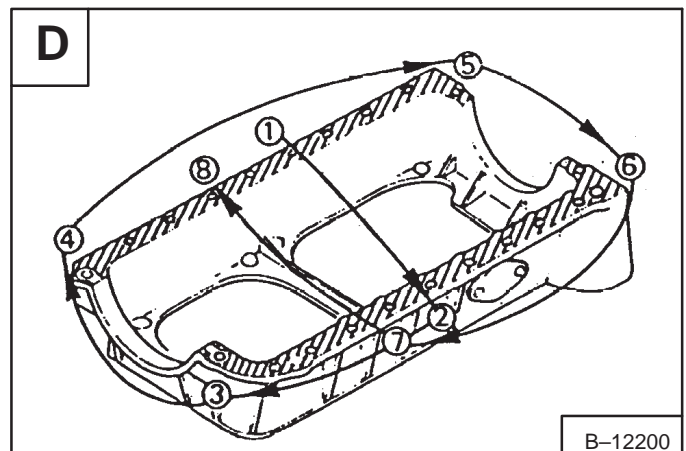

OIL PUMP

Removal And Installation

Remove the oil pan. (See Page 7–81.)

Remove the bolts at the oil pump [A].

Installation: Tighten the bolts to 10–17 ft.-lbs. (14–23 Nm) torque.

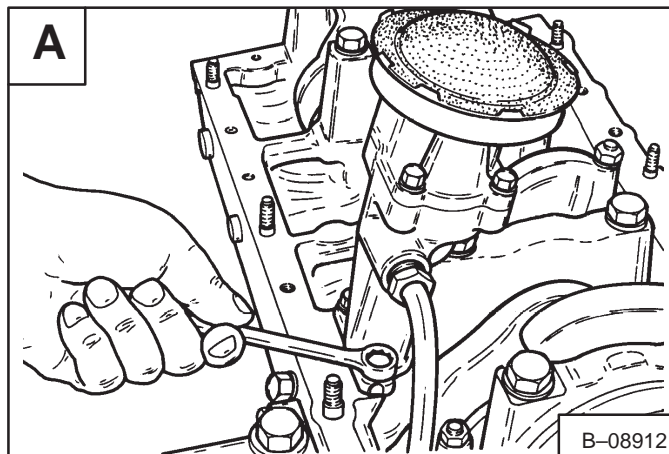

Remove the oil pump assembly from the engine block [B].

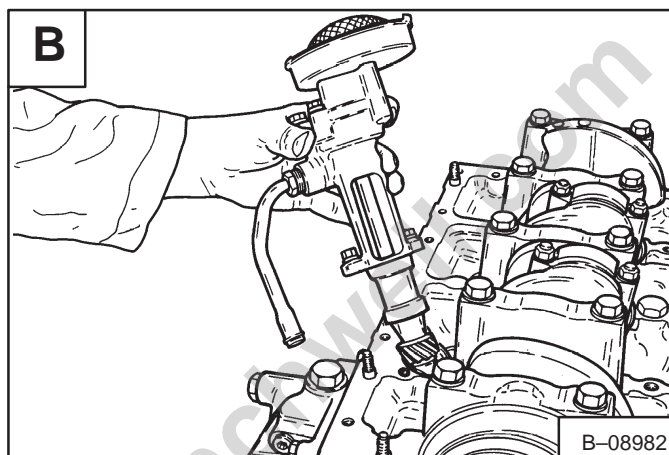

Checking

Disassemble the oil pump as illustrated [C].

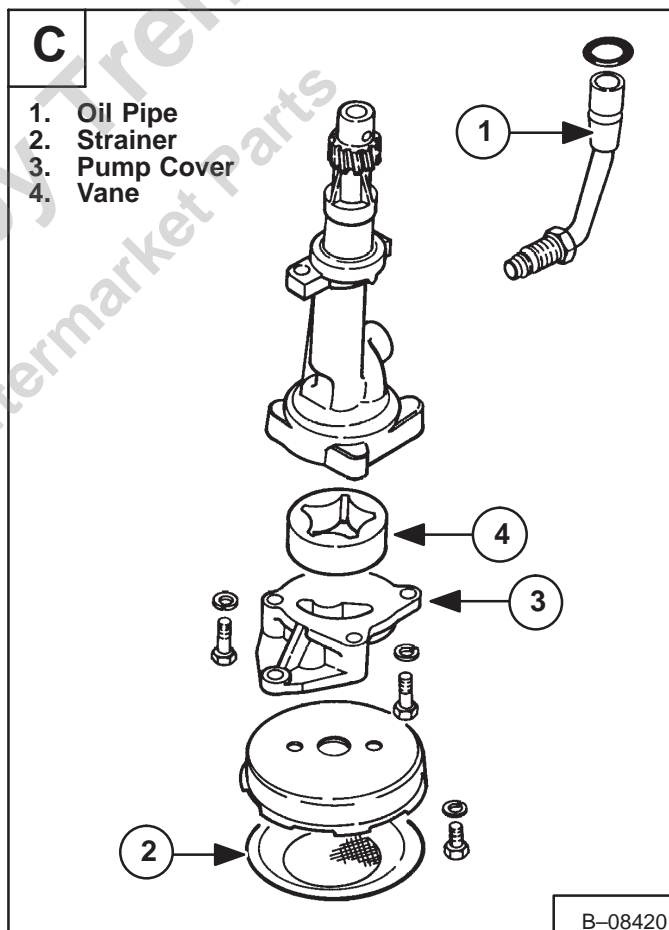

OIL PUMP (Cont'd)**Checking (Cont'd)**

Check the clearance between vane and body [A].

Standard – 0.0008–0.0028 inch (0,02–0,07 mm)
Limit – 0.0059 inch (0,15 mm)

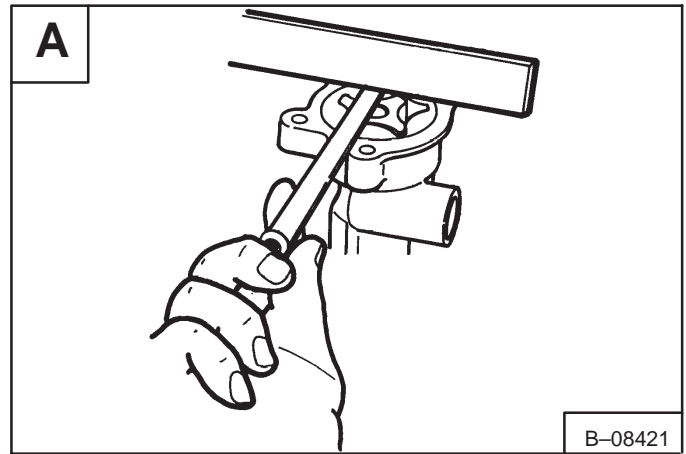

Check the clearance between the rotor and vane [B].

Standard – 0.0055 inch (0,14 mm) or less.

Check the clearance between the vane and pump body [B].

Standard – 0.0079–0.0105 inch (0,20–0,27 mm)

Check clearance between rotor shaft and pump body.

Standard – 0.0016 inch (0,04 mm)
Limit – 0.0079 inch (0,2 mm)

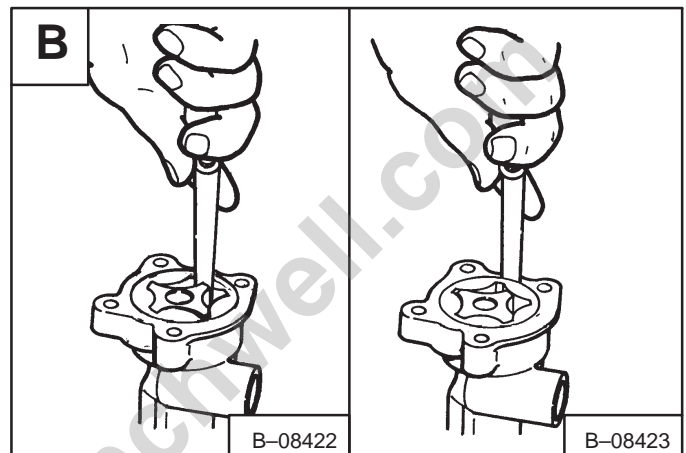
**Gear Replacement**

File off one end of the roll pin at the gear. Use a punch and hammer and remove the pin [C].

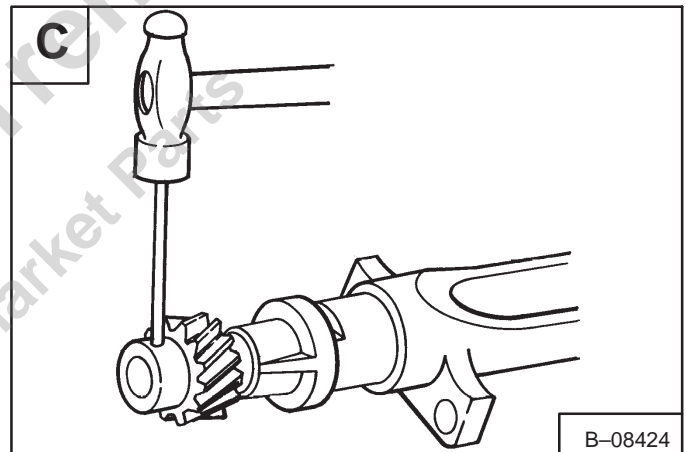

NOTE: It may be necessary to drill a hole in one side of the gear for service as it does not have a hole on both sides [D].

Installation: Install the gear and new pin. Peen the end of the pin after installation.

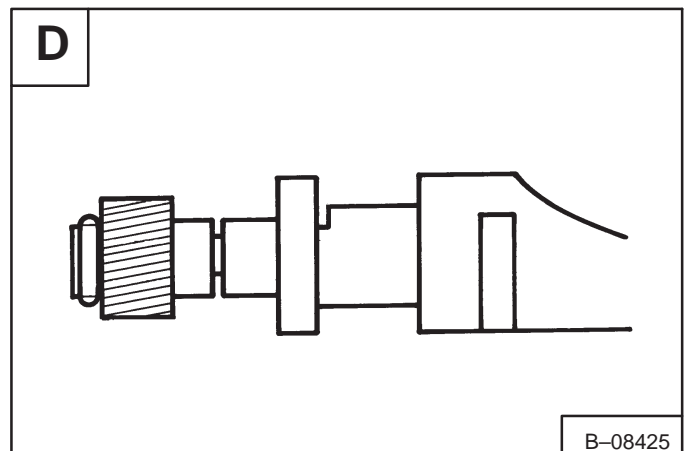

OIL PUMP (Cont'd)**Rotor Replacement**

Remove the pin at the rotor using a punch and hammer [A].

Installation: When installing the new pin in the rotor, make sure to check the end of the pin that it does not project from the end of the rotor [A].

After the oil pump is assembled, put oil into the pump and turn the shaft to prime the pump.

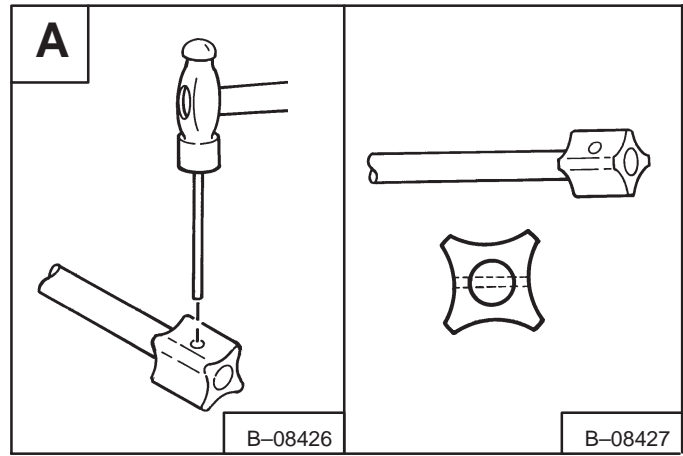
**Oil Pump Relief Valve**

Remove the relief valve from the oil filter housing [B].

Check the relief valve and clean. Replace as needed.

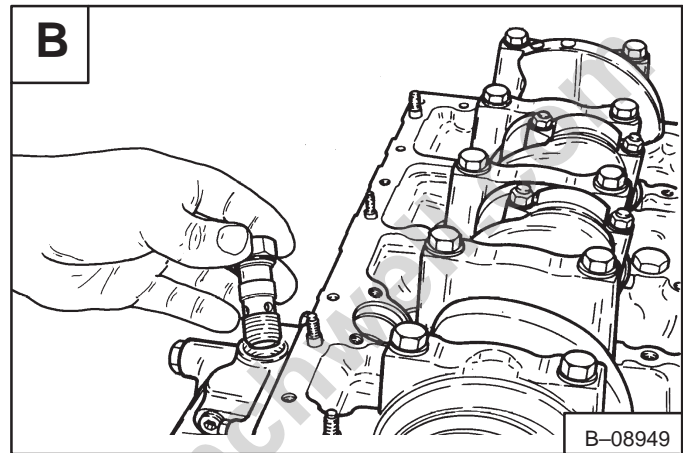
**Oil Filter Housing And Block**

To remove the oil filter block & housing, disconnect the tubelines (Item 1) [C] & [D].

remove the four mounting bolts (Item 2) [C] at the block.

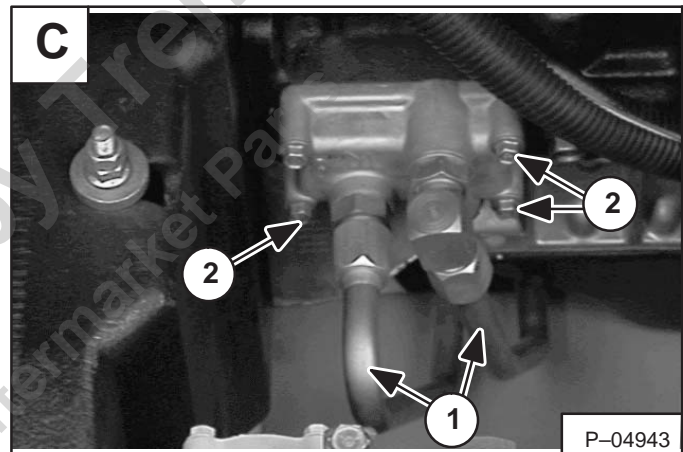

Remove the two mounting bolts (Item 2) [D] at the oil filter housing.

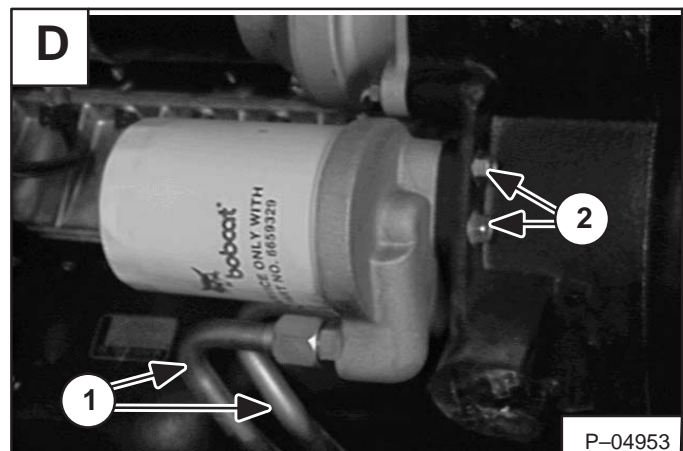

WATER PUMP

Removal And Installation

Remove the alternator belt.

Remove the water pump pulley [A].

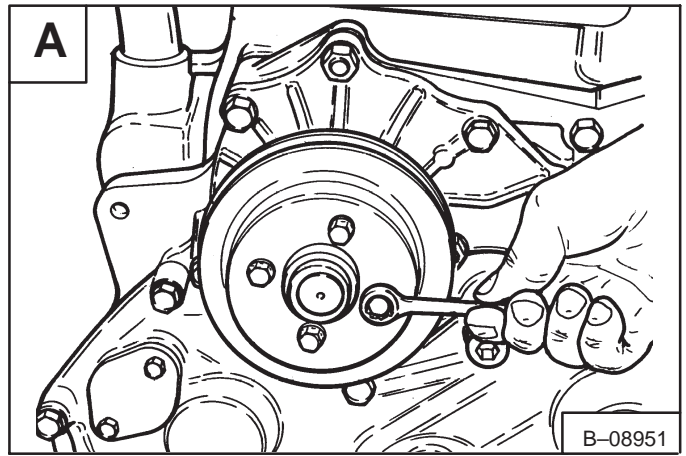

Remove the water pump bolts [B].

Installation: Tighten the bolts to 11–18 ft.-lbs. (15–24 Nm) torque.

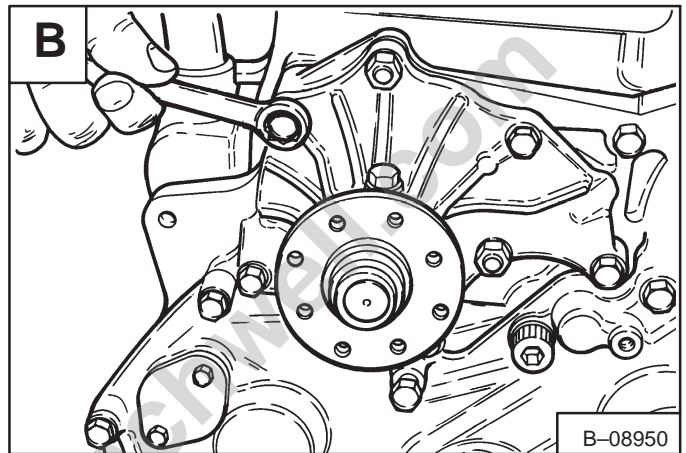

Remove the water pump from the engine block [C].

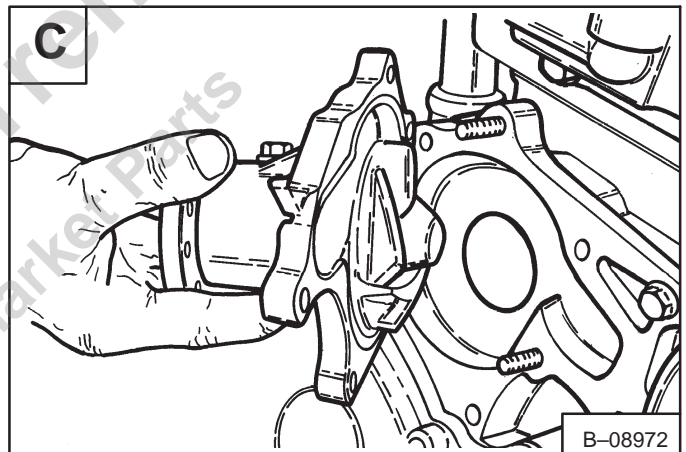

Disassembly

Remove the hub for the pulley using a press [D].

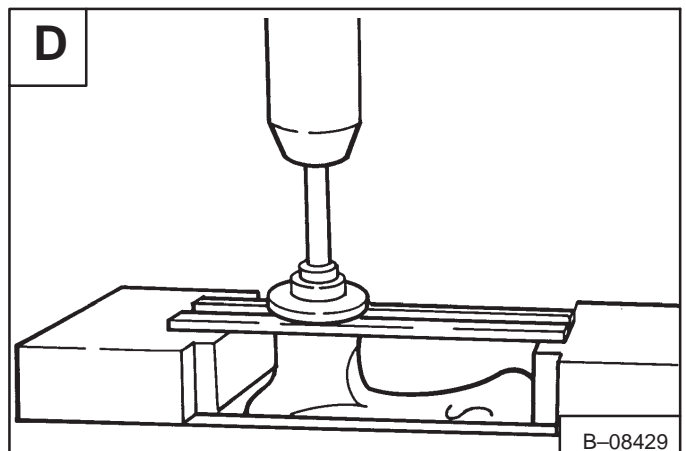

WATER PUMP (Cont'd)**Disassembly (Cont'd)**

Disassemble the water pump [A].

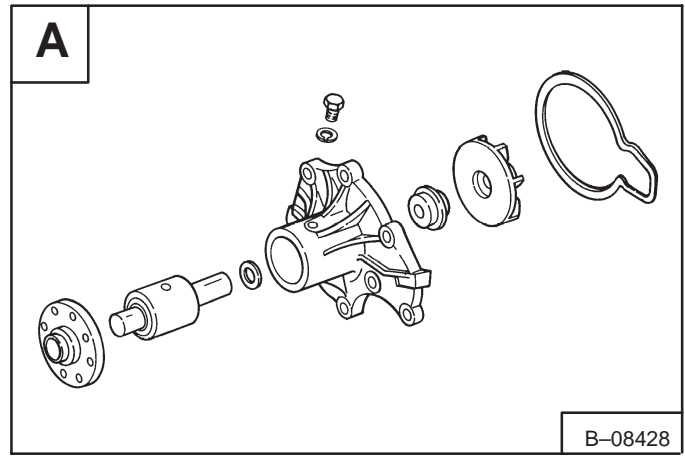

Check the bearing for abnormal noise, binding or wear [B].

Replace the parts as needed.

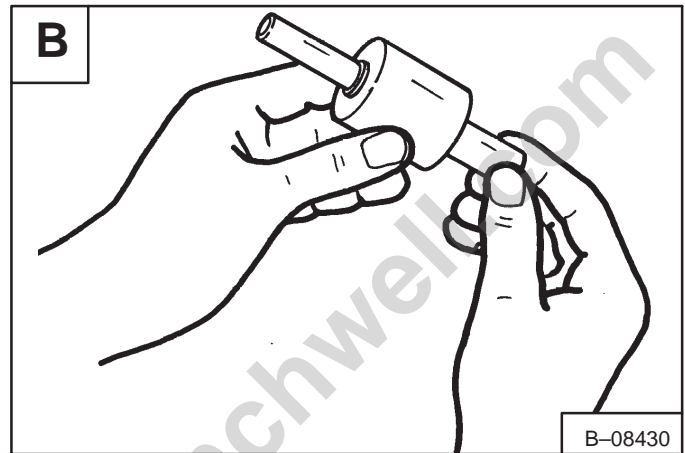
**Assembly**

Apply a thin coat of liquid gasket cement to the outer surface of the seal unit before assembly [C].

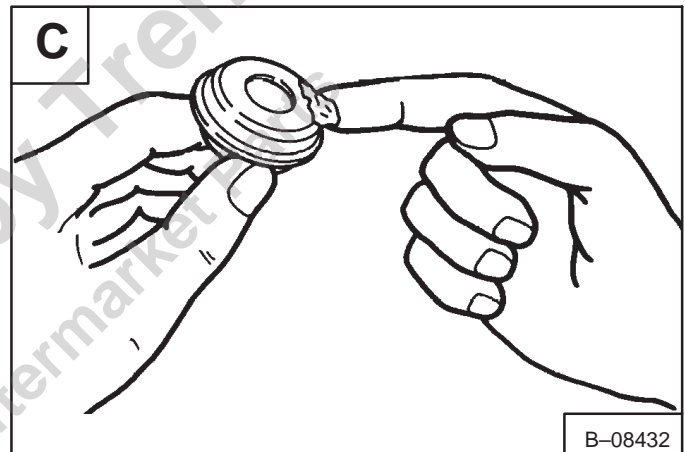

Press the bearing assembly into position by aligning the set screw hole in the bearing with that in the pump body [D].

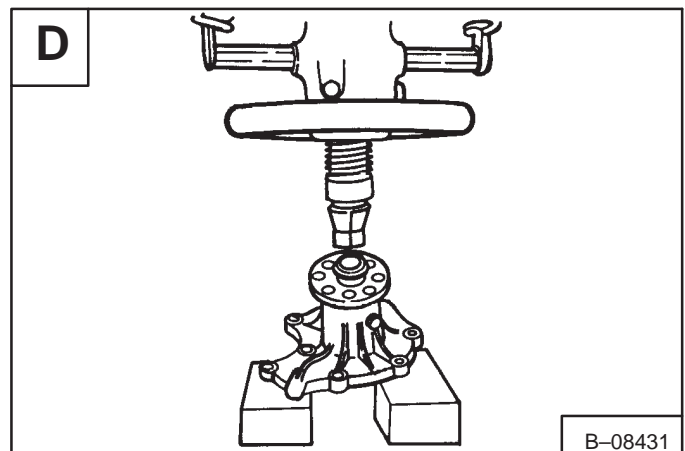

WATER PUMP (Cont'd)

Assembly (Cont'd)

After installation, check that the rear face of the impeller has the correct height **[A]**.

Height – 0.98 inch (24,8 mm)

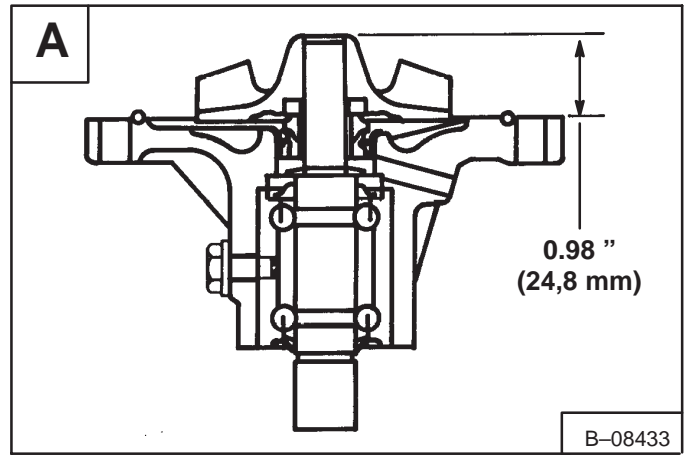

Check the distance between the pulley hub and pump body **[B]**.

Distance – 3.12–3.14 inch (79,2–79,8 mm)

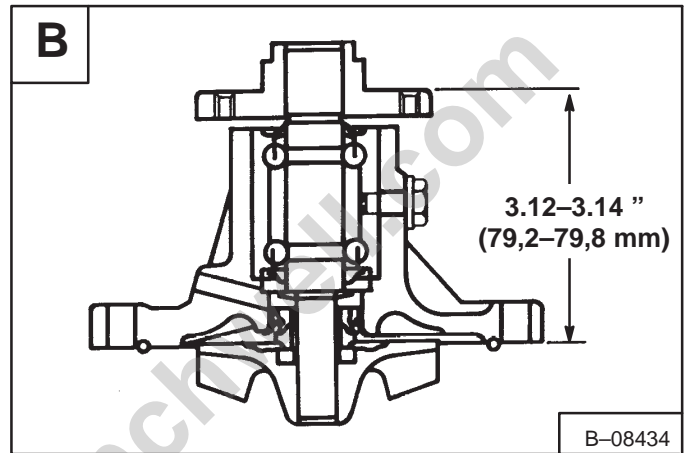

Provided for Free by Trench.com
Shop Aftermarket Parts

THERMOSTAT**Removal And Installation**

Remove the bolts from the thermostat housing [A].

Installation: Tighten the bolts to 10–17 ft.-lbs. (14–23 Nm) torque.

Remove the thermostat.

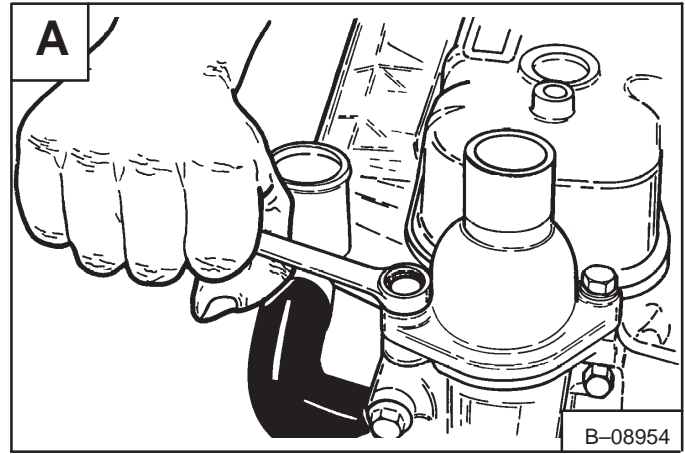
**Checking The Thermostat**

Check the thermostat opening temperature [B].

Standard – 176–183°F (80–84°C)

Check the thermostat valve lift.

Standard – Approximately 0.3 inch (7,6 mm) @ 203°F (95°C)

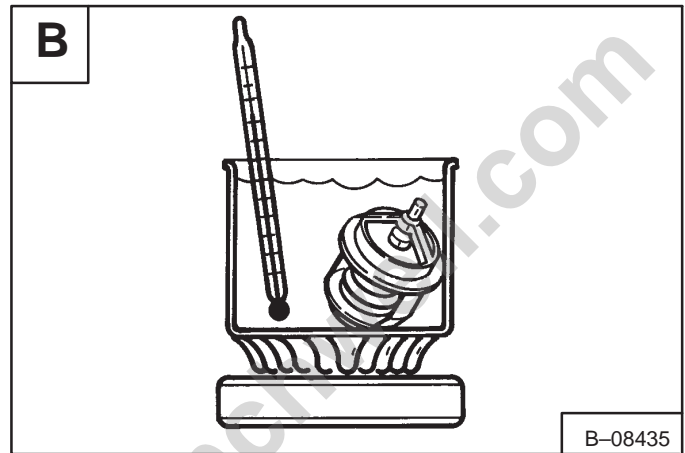

If the thermostat housing assembly is removed, tighten the bolts to 10–17 ft.-lbs. (14–34 Nm) torque [C].

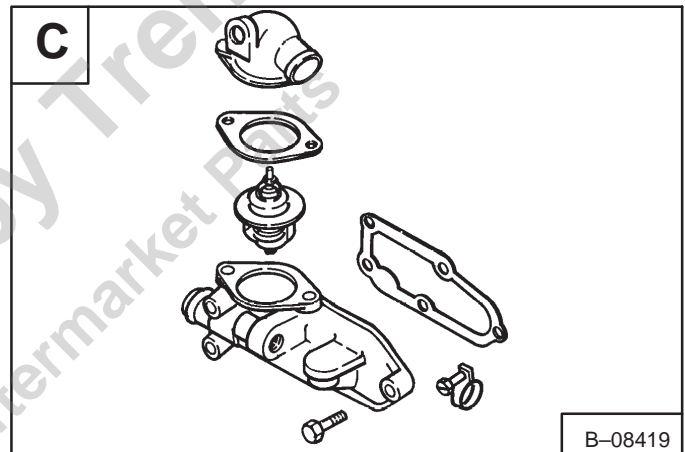

WATER JACKET TUBE

Removal And Installation

Remove the timing gearcase cover. (See Page 7-71.)

Remove the idler gear and hub. (See Page 7-73.)

Remove the fuel injection pump. (See Page 7-42.)

Remove the fuel injection pump idler gear. (See Page 7-75.)

Remove the camshaft gear. (See Page 7-76.)

Remove the timing case. (See Page 7-77.)

Remove the water pump. (See Page 7-85.)

Grip the edge of the water jacket tube with a vise grip. Use a screwdriver to pry the jacket from the engine block **[A]**.

Remove the water jacket tube from the engine block **[B]**.

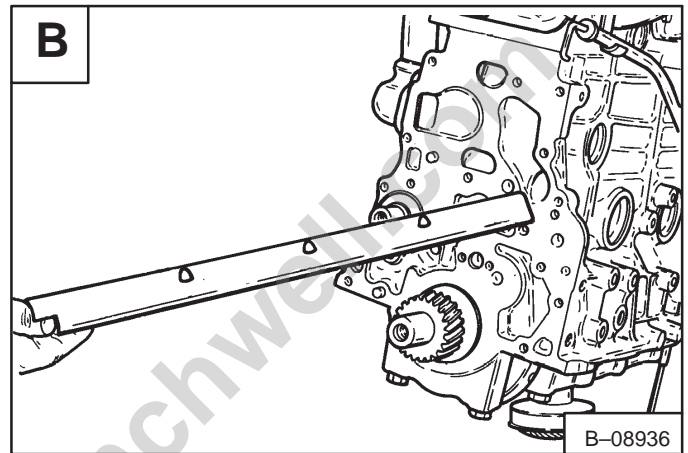
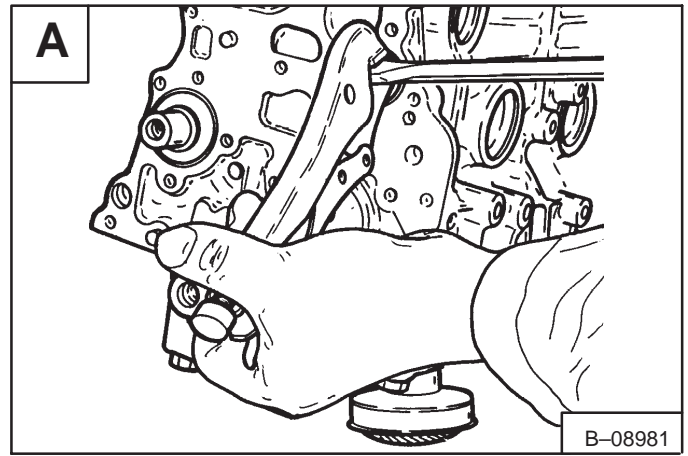

Provided for Free by Trenchwell
Shop Aftermarket Parts



Provided for Free by www.youfixthis.com
Shop Aftermarket Parts at www.frenchwell.com

SYSTEM ANALYSIS

	Page Number
BOSS® DIAGNOSTIC TOOL Procedure	8-3
BOSS® INSTRUMENT PANEL Removal And Installation	8-9
MONITOR SERVICE CODE Chart	8-5
BOSS® UNIT Removal And Installation	8-8
RPM SENSOR Adjustment	8-4
SENDER AND SENSOR Component	8-3
Service Checks	8-3
TROUBLESHOOTING THE BOSS® & LCD DISPLAY Chart	8-7

B.O.S.S. – Bobcat Operation Sensing System

L.C.D. – Liquid Crystal Diode

**SYSTEMS
ANALYSIS**



Provided for Free by www.youfixthis.com
Shop Aftermarket Parts at www.frenchwell.com

BOSS® DIAGNOSTIC TOOL

Procedure

The tool listed will be needed to do the following procedure:

MEL1400 – Diagnostic Tool

Stop the engine.

Lift and block the loader. (See Page 1–1.)

Remove the dust cap from the diagnostic connector plug. Connect the diagnostic tool plug (Item 1) [A] into the loader connector.

NOTE: Early S/N loaders have the diagnostic plug located at rear window as shown in Fig. [B].

Use the instructions from the BOSS Operation & Maintenance Manual to make service checks of BOSS system operating unit and other components [A].

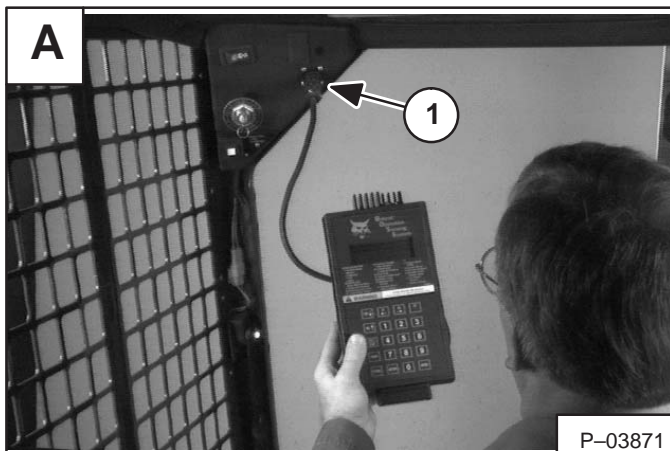

P-03871



CD-09025

SENDER AND SENSOR

Service Checks

Use the following information when checking the senders and sensor with a volt/ohmmeter:

Component	Value
TEMPERATURE SENDER	
70 degree F. (21 degree C.)	970 ohms
80 degree F. (27 degree C.)	1013 ohms
ENGINE OIL PRESSURE SENDER	
0 PSI	3 ohms Max.
6 PSI (41 kPa)	7 ohms Min.
50 PSI (345 kPa)	49 ohms
70 PSI (483 kPa)	59 ohms
TRANSMISSION CHARGE PRESSURE SENDER	
0 PSI	0–5 ohms
100 PSI (690 kPa)	58 ohms
130 PSI (896 kPa)	75 ohms
150 PSI (1034 kPa)	87 ohms
FUEL SENDER	
Full	30 ohms
Empty	270 ohms

Provided for Freeway Trendy Shop Aftermarket Parts

RPM SENSOR**Adjustment**

Continuity Resistance of 3000–3500 ohms.

Disconnect the connector **[A]** from the engine harness.

Loosen the jam nut (Item 1) **[A]** on the RPM sensor.

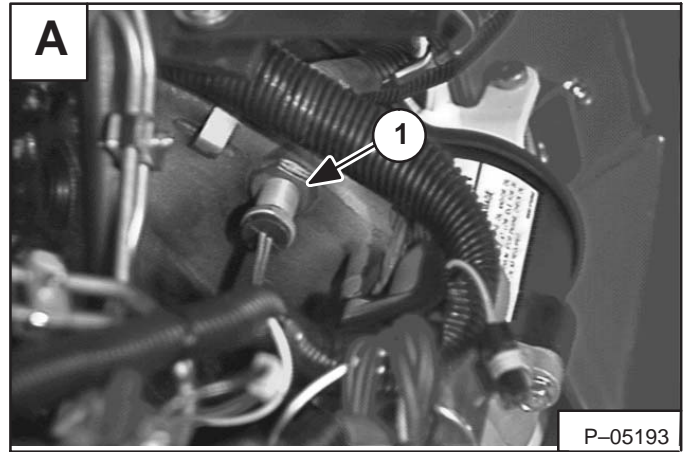

P-05193

Turn the RPM sensor (Item 1) **[B]** in until it makes contact with the engine flywheel.

Turn the jam nut until it contacts the flywheel housing. The jam nut should not be tightened, it needs to turn with the RPM sensor when the sensor is turned back out for adjustment.

Turn the RPM sensor and the jam nut out from the flywheel. Set a clearance of 0.050" (1.27 mm) between the jam nut and the housing with a feeler gauge **[B]**.

Retighten the jam nut.

NOTE: The plastic tip is used as a gauge to set a new RPM SENSOR. The plastic tip is designed to come off after the engine is started.

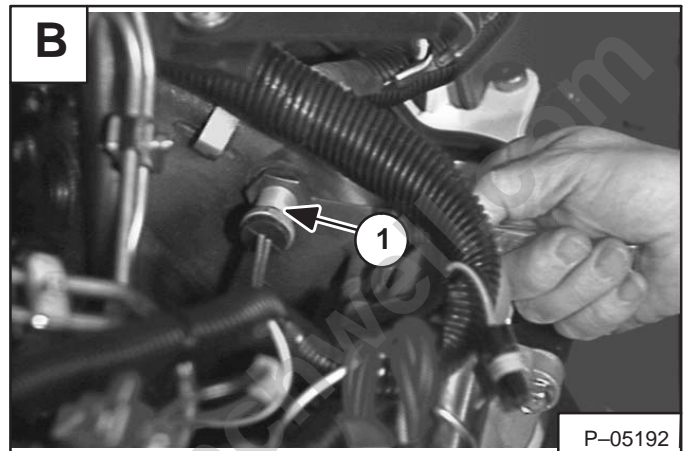

P-05192

SERVICE CODES

Chart







The following list references the defect codes that are transmitted to the instrument panel display which can occur. Some service procedures for correcting the problems can be found in this manual and other procedures must be performed ONLY BY QUALIFIED BOBCAT SERVICE PERSONNEL.





WARNING

Instructions are necessary before operating or servicing machine. Read and understand the Operation & Maintenance Manual, Handbook and signs (decals) on machine. Follow warnings and instructions in the manuals when making repairs, adjustments or servicing. Check for correct function after adjustments, repairs or service. Untrained operators and failure to follow instructions can cause injury or death.

W-2003-0199

SERVICE CODES		
SUBJECT	DISPLAY READS	CONDITION
Engine Coolant Level 	ECL 1	SHUTDOWN, No Coolant
Engine Coolant Temp. 	EC-1.1	SHUTDOWN, Engine Temperature
	EC-2.1	WARNING, Engine Temperature
	EC 3	Wiring Not Connected
	EC 4	Wiring Shorted
	EC 5	High Sensor Voltage
	EC 7	Sensor Out Of Range
Engine Oil Pressure 	EP 1	SHUTDOWN, Pressure
	EP 2	WARNING, Pressure
	EP 3	Wiring Not Connected
	EP 4	Wiring Shorted
	EP 5	High Sensor Voltage
	EP 7	Sensor Out Of Range
Engine Speed 	ES 1	SHUTDOWN, Engine Speed Too High
	ES-2.1	WARNING, Engine Speed Slightly High
	ES-6	Sensor No Signal
	ES-7	Sensor Out Of Range
Air Filter 	AF 2	WARNING, Restriction Too High
	AF 6	Sensor No Signal
Battery 	b-2.1	WARNING, Bad Battery
	b-2.2	WARNING, Battery Voltage
Fuel Level 	FUEL2	WARNING, Low Level
	FUEL3	Wiring Not Connected
	FUEL4	Wiring Shorted
	FUEL5	High Sensor Voltage
	FUEL7	Sensor Out Of Range

SERVICE CODES

SUBJECT	DISPLAY READS	CONDITION
Hydrostatic Charge Filter Condition 	HF1-2	WARNING, High Restriction
	HF1-6	Sensor No Signal
Hydrostatic Fluid 	HP 1	SHUTDOWN, Pressure
	HP 2	WARNING, Pressure
	HP 3	Wiring Not Connected
	HP 4	Wiring Shorted
	HP 5	High Sensor Voltage
	HP 7	Sensor Out Of Range
Hydrostatic Fluid Temperature 	HC 1	SHUTDOWN, Temperature
	HC 2	WARNING, Temperature
	HC 3	Wiring Not Connected
	HC 4	Wiring Shorted
	HC 5	High Sensor Voltage
	HC 7	Sensor Out Of Range

TROUBLESHOOTING THE BOSS® & LCD DISPLAY

Chart

SUBJECT	SYMPTOM	INDICATES	TO CORRECT SYMPTOM																																								
BOSS	Temperature related shutdown codes when no heating occurs. * NOTE: You may have some or all of the codes listed. You will have high temps, high press, low voltage and low fuel.	12 volt supply and BOSS failure.	<ol style="list-style-type: none"> 1. Check stored defects with the BOSS tool. *2. If defect list has EC1, HC1, EC2.1, HC2, EP3, EP7, HP7, B2.2, low fuel, Fuel 7 and last occurrence hr. readings are within a hundredth, the BOSS is defective and must be replaced. 3. Using a voltmeter, check the alternator output. 																																								
LCD Display	Intermittent code of ES6 while engine running.	Sensor No Signal or No RPM's.	<ol style="list-style-type: none"> 1. ES6 will occur if the loader is stalled or shutdown during run cycle. The code is generated due to the lack of RPM and the existence of residual pressure in the system. 																																								
	Display is dead – No Icons, Bar Graphs, Hourmeter.	Lack of 5.0 volts regulated power.	<ol style="list-style-type: none"> 1. Check pin A for 5.0 volts. If 5.0 volts is present replace the display. 2. If no power exists at pin A, install BOSS backup to confirm the BOSS system. 3. If the problem still exists, check the harness for continuity. 																																								
	<div style="border: 1px solid black; padding: 10px;"> <p style="text-align: center;">LCD DISPLAY CONNECTOR</p> <table style="margin: auto; border-collapse: collapse;"> <tr> <td style="text-align: center; padding: 5px;">A</td> <td style="text-align: center; padding: 5px;">B</td> <td style="text-align: center; padding: 5px;">C</td> <td style="text-align: center; padding: 5px;">D</td> <td style="text-align: center; padding: 5px;">E</td> </tr> <tr> <td style="text-align: center; padding: 5px;">Orange</td> <td style="text-align: center; padding: 5px;">Purple/Red</td> <td style="text-align: center; padding: 5px;">Purple/White</td> <td style="text-align: center; padding: 5px;">Black</td> <td style="text-align: center; padding: 5px;">Orange</td> </tr> <tr> <td colspan="4" style="text-align: center; padding: 5px;">12 Volt – Back Light</td> <td></td> </tr> <tr> <td colspan="4" style="text-align: center; padding: 5px;">Ground</td> <td></td> </tr> <tr> <td colspan="4" style="text-align: center; padding: 5px;">Negative Com. .5 to 1.5 Volts</td> <td></td> </tr> <tr> <td colspan="4" style="text-align: center; padding: 5px;">Positive Com. 3.5 to 4 Volts</td> <td></td> </tr> <tr> <td colspan="4" style="text-align: center; padding: 5px;">5.0 Volts Regulated Power</td> <td></td> </tr> <tr> <td colspan="5" style="text-align: center; padding: 5px;">Power Display Operation</td> </tr> </table> </div>			A	B	C	D	E	Orange	Purple/Red	Purple/White	Black	Orange	12 Volt – Back Light					Ground					Negative Com. .5 to 1.5 Volts					Positive Com. 3.5 to 4 Volts					5.0 Volts Regulated Power					Power Display Operation				
	A	B	C	D	E																																						
	Orange	Purple/Red	Purple/White	Black	Orange																																						
	12 Volt – Back Light																																										
Ground																																											
Negative Com. .5 to 1.5 Volts																																											
Positive Com. 3.5 to 4 Volts																																											
5.0 Volts Regulated Power																																											
Power Display Operation																																											
During an active WARNING display, reset occurs and the hourmeter becomes all zero's.	Low voltage (5.0) triggered reset.	<ol style="list-style-type: none"> 1. Turn the ignition switch OFF. Re-starting will return hourmeter reading. 2. If re-starting will not return hourmeter reading, check pins B & C as stated in Step 5 below. 																																									
Garbled message, missing segments, etc.	The display is not fault tolerant. Also can be an indication of poor internal connections.	<ol style="list-style-type: none"> 1. Turn the ignition switch OFF and re-start. A fault is an invalid message that the display tries to display. Generally a fault occurs if communications of two messages are combined on the display. 																																									
After glow sequence or after a WARNING goes away, the Icon remains ON.		<ol style="list-style-type: none"> 1. Turn the key OFF and re-start. 																																									
No Bar Graphs, no Hours. * NOTE: The display has caused the problem by locking the communication lines and stopping communications from the BOSS.	Bad display or BOSS is not communicating.	<ol style="list-style-type: none"> 1. Plug in the BOSS tool and start the engine. 2. If data is being received by the BOSS tool, the BOSS unit is not the cause of the problem. 3. If no data is received at the BOSS tool, disconnect the LCD display. *4. If messages are now received at the tool, the display is the problem. If problem still exists go to Step 5. 5. Check pins B & C for signal. 6. If there is no signal, install BOSS backup unit. 7. If the problem still exists, check the harness for continuity. 																																									

BOSS® UNIT**Removal And Installation**

Raise the loader operator cab. (See Page 1-1.)

Loosen the nuts (Item 1) **[A]** from the sensing system unit (Item 2) **[A]**.

Slide the unit forward in the mounting slots and remove it from the operator cab.

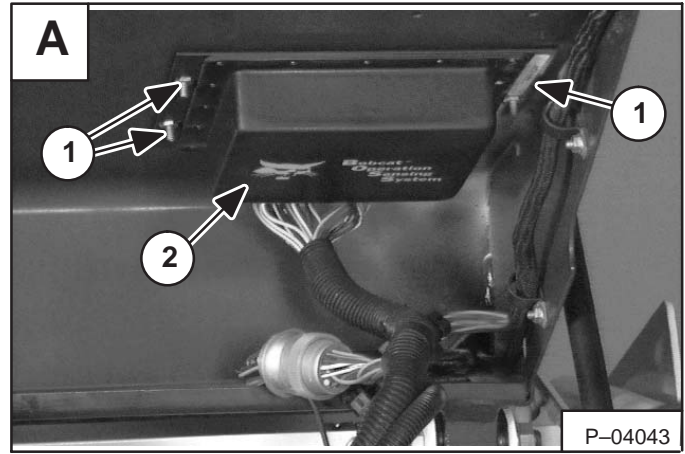

Remove the two connectors (Item 1) **[B]** from the sensing system unit (Item 2) **[B]**.

Installation: Put the heads of the mounting bolts into the slots of the operator cab and slide the unit back into place. Tighten the three mounting nuts to 80–90 in.-lbs. (9–10 Nm) torque.

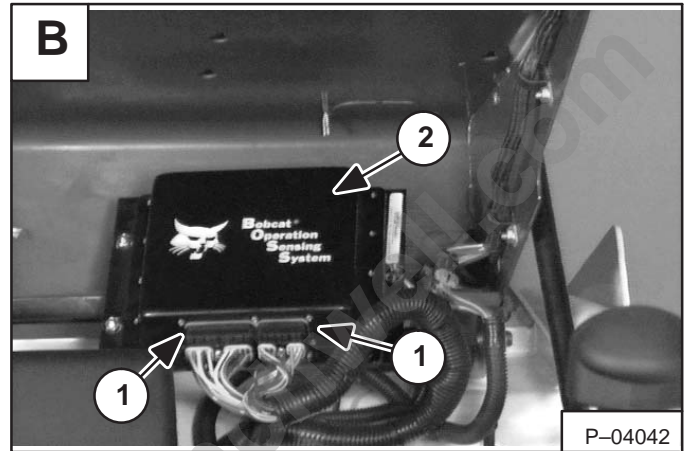

BOSS® INSTRUMENT PANEL**Removal And Installation**

Pry the rubber light mount from the operator cab (both sides) [A].

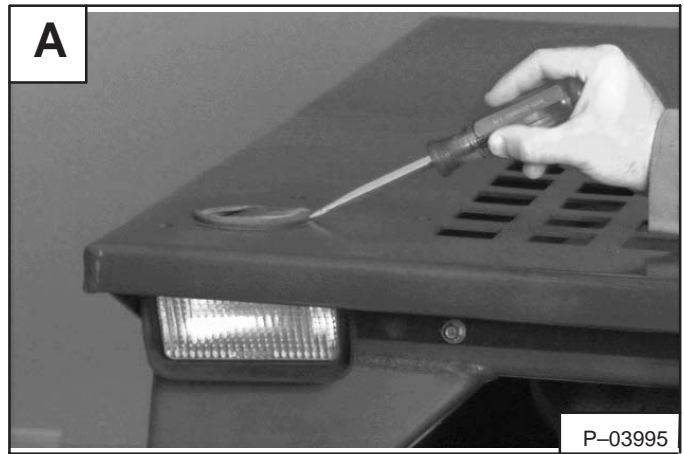

Lower the light from the operator cab and remove the three panel mounting bolts (Item 1) [B] (both sides.)

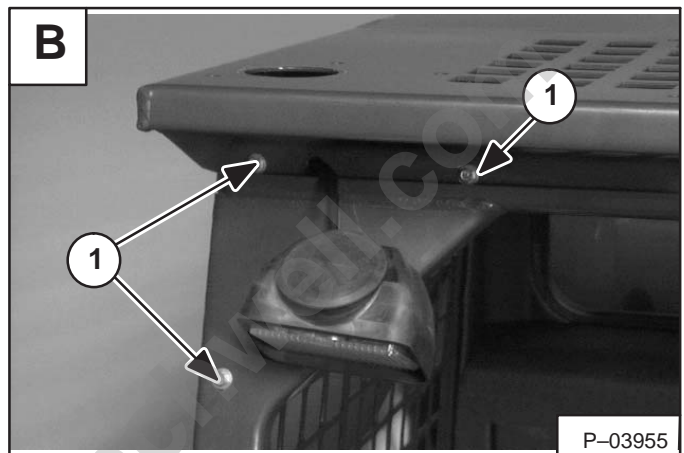

Pull the left panel (Item 1) [C] down from the operator cab.

Installation: Do not overtighten the panel mounting bolts to prevent stripping the threaded holes of the panels.

Disconnect the wire harness connectors from the panel and remove the panel.

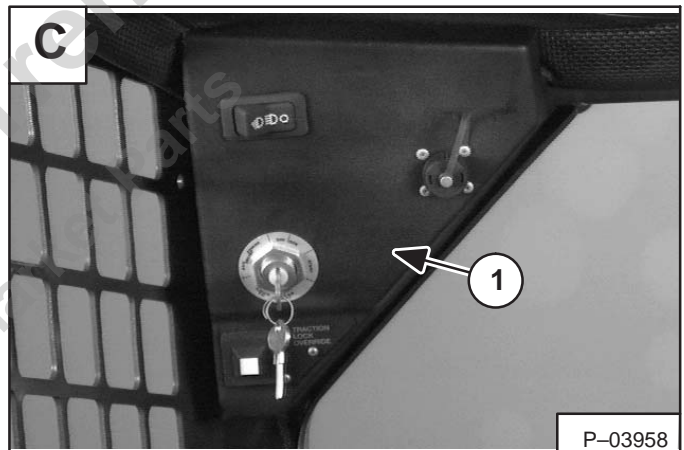

Remove the three mounting bolts and pull the right panel (Item 1) [D] down from the operator cab.

Installation: Do not overtighten the panel mounting bolts to prevent stripping the threaded holes of the panels.

Disconnect the wire harness connectors from the panel and remove the panel.

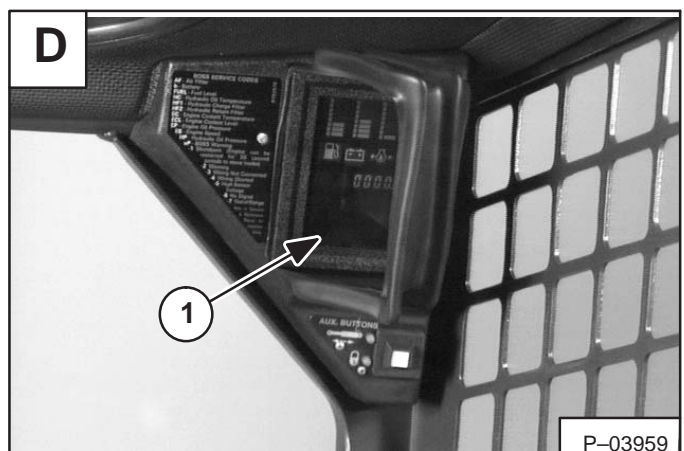



Provided for Free by www.youfixthis.com
Shop Aftermarket Parts at www.frenchwell.com

SPECIFICATIONS

	Page Number
DECIMAL & MILLIMETER EQUIVALENTS	
Chart	9-17
ENGINE SPECIFICATIONS	
Camshaft	9-6
Connecting Rod & Bearing	9-6
Crankshaft	9-7
Cylinder Head	9-5
Cylinder Liners	9-6
Fuel System	9-7
Idler Gear	9-7
Oil Pump	9-7
Pistons, Pins & Rings	9-6
Rocker Arm	9-5
Tappets	9-5
Valve Springs	9-5
Valve, Valve Guide & Seat Insert	9-5
HYDRAULIC CONNECTION SPECIFICATIONS	
Flare Fitting	9-12
O-ring Face Seal Connection	9-12
O-ring Flare Fitting	9-13
Port Seal Fitting	9-15
Straight Thread O-ring Fitting	9-12
Tubelines And Hoses	9-12
HYDRAULIC/HYDROSTATIC FLUID SPECIFICATIONS	
Specifications	9-16
LOADER SPECIFICATIONS	
Capacities	9-4
Controls	9-3
Drive System	9-4
Electrical	9-4
Engine	9-3
Hydraulic System	9-4
Loader Dimensions	9-3
Operation & Performance	9-3
Tires	9-4
TORQUE SPECIFICATIONS FOR BOLTS	
Torque For General SAE Bolts	9-10
Torque For General Metric Bolts	9-11
TORQUE SPECIFICATIONS FOR LOADER	
Specifications	9-9
U.S. TO METRIC CONVERSION	
Chart	9-17

SPECIFICATIONS



Provided for Free by www.menckwell.com
Shop Aftermarket Parts

LOADER SPECIFICATIONS

Loader Dimensions

- Dimensions are given for loader equipped with standard tires and dirt bucket. Dimensions may vary with other types. All dimensions are shown in inches. Respective metric dimensions are given in millimeters enclosed by parentheses.
- Where applicable, specifications conform to SAE/ISO standards and are subject to change without notice.

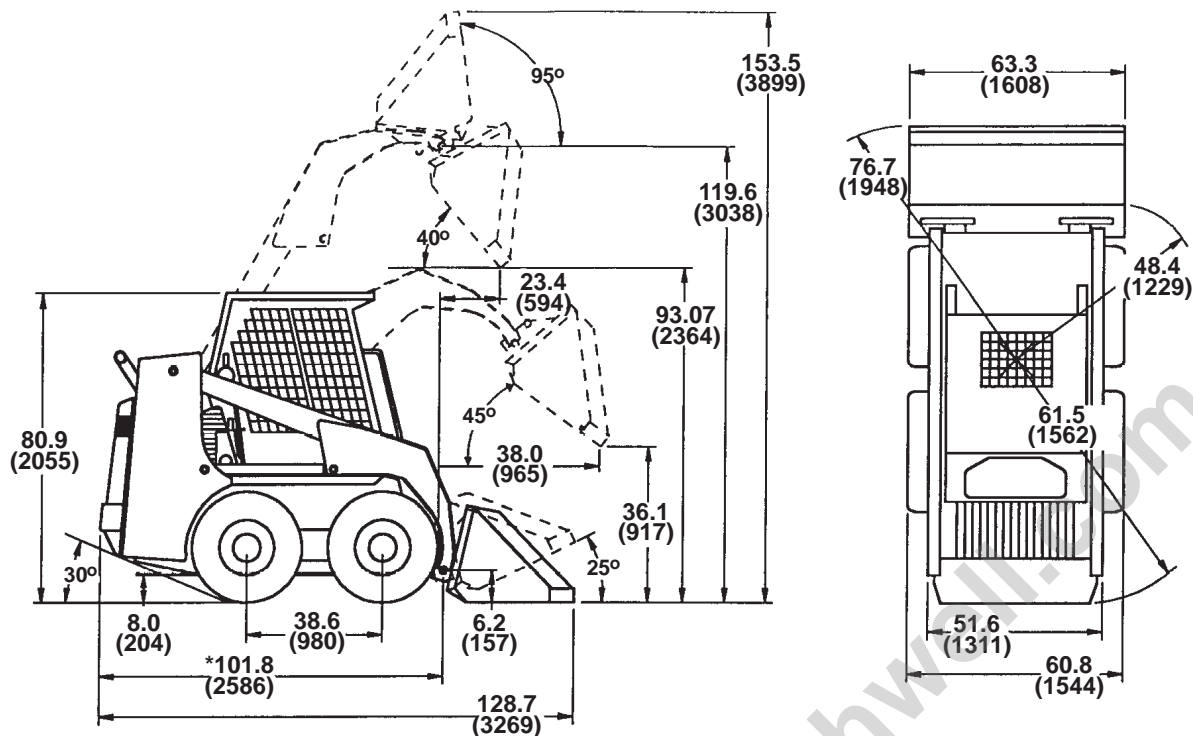

* Overall Length W/O Bucket

MC-1113

This loader was designed without counterweights or ballasts. Changes of structure or weight distribution of the loader can cause changes in control and steering response and can cause failure of the loader parts.

Performance	853
Operating Weight	6497 lbs. (2950 kg)
Rated Operating Capacity	1700 lbs. (772 kg)
Tipping Load	3420 lbs. (1533 kg)
Travel Speed	Infinitely variable 0-6.3 MPH (10,1 km/hr.)
Controls	
Vehicle	Direction & speed controlled by two hand levers.
Loader Function	Lift, tilt functions controlled by separate foot pedals. Auxiliary functions controlled by electrical push buttons on steering levers
Engine	Hand lever throttle; key-type starter switch.
Main Drive	Hydrostatic
Parking Brake	Mechanical disc, foot operated pedal
Engine	
Make	Isuzu
Model	4JB1 PK-03
Fuel	Diesel
Horsepower	62 HP (46 kW)
Maximum Governed RPM	2600 RPM
Torque	137 ft.-lbs. (186 Nm) @ 1800 RPM
Number of Cylinders	Four
Bore/Stroke	3.66/4.02(93/102)
Displacement	169 cu.in. (2769 cu. cm.)
Cooling System	Liquid
Lubrication	Pressure System W/Filter
Crankcase Ventilation	External
Air Cleaner	Dry replaceable cartridge, dual safety element
Ignition	Diesel-Compression
Low Idle	1150 RPM
High Idle	2750 RPM

LOADER SPECIFICATIONS (Cont'd)

853	
Hydraulic System	Engine driven gear type
Pump	18.0 GPM (68,1 L/min.) @ 2750 RPM @ 1150 PSI (7929 kPa)
Pump Capacity	2550–2600 PSI (17580–17924 kPa) @ Quick Couplers
System Main Relief	Full flow replaceable 4 micron synthetic medial element
Filters (charge & implement)	
Hydraulic Cylinders	Doubleacting
Bore Diameter:	
Lift Cylinder (2)	2.25 (57,2)
Tilt Cylinder (1)	3.25 (82,6)
Rod Diameter:	
Lift Cylinder (2)	1.50 (38,1)
Tilt Cylinder (1)	1.50 (38,1)
Stroke:	
Lift Cylinder (2)	33.5 (851)
Tilt Cylinder (1)	18.9 (480)
Control Valve	3–spool, open center, series type W/float detent on lift, single spool electrical control front auxiliaries.
Fluid Lines	SAE standard tubes, hoses & fittings
Hydraulic Function Time:	
Raise Lift Arms to Maximum Height	4.0 Seconds
Lower Lift Arms from Maximum Height . . .	3.4 Seconds
Move Empty Bucket to Dump Position . . .	2.3 Seconds
Move Bucket to Retracted Position	1.9 Seconds
Fluid Type	Bobcat Fluid (P/N 6563328); If fluid is not available, use 10W–30/10W–40 Class SE, SF, SG Motor Oil for temperatures above 0°F (–18°C) & 5W–30 Motor Oil for temperatures below 0°F (–18°C).
Electrical	
Alternator	Belt drive, 55 amps. Open
Battery	12 volt, 700 cold crank amps. @ 0°F (–18°C) 170 min. reserve capacity
Starter	12 volt, 3.7 HP (2,8 kW)
Drive System	
Transmission	Tandem hydro. pumps infinitely variable, driving 2 fully reversing hydrostatic motors
Final Drive	Gear Reduction & #100 HS roller chain & sprockets in sealed chaincase with oil lubrication
Total Engine to Wheel Reduction	47:27:1
Capacities	
Cooling System	22 qts. (20,8 L)
Fuel	25 gals. (95 L)
Engine Oil W/Filter	8 qts. (7,6 L)
Hydraulic Reservoir	15.5 qts. (14,7 L)
Hydraulic/Hydrostatic System	8 gals. (30,3 L)
Chaincase Reservoir	9 gals. (34,1 L)
Tires	
Standard	8.25–15, 6 Ply Rating, Nylon with Bar Lug Tread
Pressure	45–50 PSI (310–345 kPa)
Flotation	12:00–16,5, 6 Ply Rating, Nylon with Sure Grip Lug
Pressure	30–35 PSI (207–240 kPa)

ENGINE SPECIFICATIONS

All dimensions are given in inches. Respective metric dimensions are given in millimeters enclosed by parentheses.

Cylinder Head

Distortion	Std. 0.002 (0,05)
	Limit 0.008 (0,20)
Re-Grind	Limit 0.012 (0,30)
Valve Seat Angle	45 degrees

Valve, Valve Guide & Seat Insert

Valve Seat Width	
Intake	Std. 0.067 (1,70)
	Limit 0.087 (2,20)
Exhaust	Std. 0.079 (2,00)
	Limit 0.098 (2,50)
Valve Head Depth	
Intake	Std. 0.029 (0,73)
	Limit 0.05 (1,28)
Exhaust	Std. 0.028 (0,70)
	Limit 0.047 (1,20)
Valve Seat Angle	45 degrees
Valve Head Thickness	Std. 0.07 (1,80)
	Limit 0.059 (1,50)
Valve Stem Diameter	
Intake	Std. 0.3128–0.3134 (7,945–7,960)
	Limit 0.310 (7,87)
Exhaust	Std. 0.3119–0.3124 (7,922–7,935)
	Limit 0.310 (7,87)
Valve & Valve Guide Clearance	
Intake	Std. 0.0015–0.0027 (0,038–0,069)
	Limit 0.008 (0,20)
Exhaust	Std. 0.0025–0.0038 (0,064–0,097)
	Limit 0.010 (0,25)
Valve Guide Height	0.51 (13,0)

Valve Springs

Free Length	
Inner	Std. 1.783 (45,3)
	Limit 1.748 (44,4)
Outer	Std. 1.957 (49,7)
	Limit 1,898 (48,2)
Inclination	
Inner	Limit 0.118 (3,00)
Outer	Limit 0.126 (3,20)
Tension	
Inner – Set Length	1.46 (37) Std. 13 lbs. (5,9 kg)
	Limit 11 lbs. (5,02 kg)
Outer – Set Length	1.54 (39) Std. 46 lbs. (20,9 kg)
	Limit 40 lbs. (18,2 kg)

Rocker Arm

Shaft Diameter	Std. 0.7478–0.7486 (18,99–19,01)
	Limit 0.7427 (18,86)
Rocker Arm I.D.	Std. 0.7489–0.7497 (19,02–19,04)
	Limit 0.7505 (19,06)
Clearance Between Rocker Arm & Shaft	Std. 0.0003–0.0020 (0,008–0,05)
	Limit 0.0078 (0,2)
Push Rod Run-Out	Limit 0.012 (0,3)

Tappets

Diameter	Std. 0.511–0.5114 (12,98–12,99)
	Limit 0.510 (12,95)
Clearance	Std. 0.0012 (0,03)
	Limit 0.0039 (0,10)

ENGINE SPECIFICATIONS (Cont'd)

All dimensions are given in inches. Respective metric dimensions are given in millimeters enclosed by parentheses.

Piston, Pin & Rings

Piston O.D.	
Piston Grade A	3.661–3.662 (92,99–93,015)
Piston Grade C	3.662–3.663 (93,015–93,04)
Clearance in Bore	Std. 0.001–0.0018 (0,025–0,04)
Clearance Between Ring & Piston Groove	
1st Compression	Std. 0.0035–0.0049 (0,09–0,124) Limit 0.006 (0,15)
2nd Compression	Std. 0.002–0.0033 (0,05–0,084) Limit 0.006 (0,15)
Oil	Std. 0.001–0.003 (0,03–0,08) Limit 0.006 (0,15)
Piston Ring Gap	
Compression	Std. 0.008–0.016 (0,20–0,40) Limit 0.059 (1,50)
Oil	Std. 0.004–0.012 (0,1–0,30) Limit 0.0059 (1,50)
Piston Pin O.D.	Std. 1.220 (30,99) Limit 1.219 (30,96)
Inference Fit Clearance	0.00008–0.0006 (0,002–0,015)

Connecting Rod & Bearing

Connecting Rod Misalignment	Std. 0.002 (0,05) or less Limit 0.0079 (0,20)
Small End Bushing I.D.	Std. 1.2208–1.2211 (31,008–31,06)
Clearance Between Piston Pin & Small End Bushing	St. 0.0003–0.00079 (0,008–0,20) Limit 0.0002 (0,05)
Clearance Between Crankshaft Journal & Bearing	Std. 0.001–0.0026 (0,029–0,066) Limit 0.004 (0,10)

Cylinder Liners

Cylinder Liner I.D.	Std. 3.6622–2.6638 (93,02–93,06) Limit 3.6653 (93,10)
Inference Fit in Block	0.00004–0.00075 (0,001–0,019)
Projection Above Block	0.0–0.0039 (0,0–0,01)
Cylinder Liner Bore I.D.	
Piston Grade A	Min. Dia. 3.6622–3.6630 (93,01–93,04)
Piston Grade C	Min. Dia. 3.6630–3.6638 (93,04–93,06)

Camshaft

Gear Backlash	Std. 0.004–0.007 (0,10–0,17) Limit 0.012 (0,30)
End Play	Std. 0.0002–0.0045 (0,05–0,114) Limit 0.0079 (0,20)
Journal Diameter	Std. 1.9663–1.9675 (49,944–49,975) Limit 1.9528 (49,60)
Camshaft Bearing I.D.	Std. 1.9685–1.9697 (50,0–50,03)
Clearance	Std. 0.0020 (0,05) Limit 0.0047 (0,12)
Camshaft Run-Out	Limit 0.0039 (0,10)
Cam Lobe Height	Std. 1.654 (42,010) Limit 1.640 (41,66)

ENGINE SPECIFICATIONS (Cont'd)

All dimensions are given in inches. Respective metric dimensions are given in millimeters enclosed by parentheses.

NOTE: Crankshaft is Tuffride coated and cannot be re-ground.

Crankshaft

End Play	Std. 0.004 (0,10) Limit 0.012 (0,31)
Connecting Rod Journal O.D.	Std. 2.0833–2.0839 (52,92–52,93) Limit 2.0829 (52,91)
Main Bearing Journal O.D.	Std. 2.7526–2.7532 (69,92–69,93) Limit 2.7524 (69,91)
Clearance Between Journal & Main Bearing	Std. 0.0014–0.0041 (0,035–0,080) Limit 0.0043 (0,11)
Crankshaft Run-Out	Std. 0.002 (0,05) or less Limit 0.003 (0,08)

Idler Gear

End Play	Std. 0.003 (0,07) Limit 0.008 (0,20)
Backlash	Std. 0.004–0.007 (0,10–0,017) Limit 0.012 (0,30)
Idler Gear Hub O.D.	Std. 1.7695–1.7707 (44,95–44,98) Limit 1.7656 (44,85)
Clearance Between Hub & Gear	Std. 0.0009–0.003 (0,025–0,085) Limit 0.0079 (0,20)
Bearing Replacement	
Projection	0.016–0.024 (0,40–0,60)
Height	0.933–0.945 (23,7–24,0)

Oil Pump

End Play Between Vane & Body	Std. 0.0008–0.0028 (0,02–0,07) Limit 0.0059 (0,15)
Clearance Between Rotor & Vane	Std. 0.0055 (0,14) or less
Clearance Between Vane & Body	Std. 0.0079–0.0105 (0,20–0,27)
Clearance Between Rotor Shaft & Body	Std. 0.0016 (0,04) Limit 0.0079 (0,20)
Oil Pump Pressure	57–71 PSI (393–490 kPa) @ 1400 RPM 21 PSI (145 kPa) @ Idle RPM

Fuel System

Pump Type	Bosch VE
Nozzles	Bosch Multi-hole (4 orifices)
Injector Pressure (Opening)	2630 PSI (18134 kPa)
Supple Pump Pressure	
Idle RPM	37 PSI (255 kPa)
High Idler RPM	71 PSI (490 kPa)
Injection Pump Timing	17° BTDC

TORQUE SPECIFICATIONS FOR LOADER

Specifications

Item	Ft.-Lbs.	Nm
Air Cleaner Mounting Bolts	25-28	34-38
Alternator Pulley Nut	50	68
Axle Hub Mounting Bolt	175-190	237-258
Axle Sprocket Bolt	475-525	644-711
Bob-Tach Pivot Pin Bolts	220-245	298-332
Bob-Tach Lever Pivot Bolt	25-28	34-38
Brake Block Mounting Bolts	65-70	88-95
Brake Lever Bolt	65-70	88-95
Brake Pad Mounting Bolts	65-70	88-95
Camshaft Gear Bolts	72-87	98-118
Camshaft Retainer Plate Bolts	11-17	15-23
Chaincase to Main Frame Bolts & Nuts	90-100	122-136
Connecting Rod Bolts	58-65	79-88
Control Pedal Linkage Bolts	21-25	28-34
Control Valve Mounting Bolts & Nuts	15-16	20-22
Crankshaft Pulley Nut	123-152	167-206
Cylinder Head Bolts	New 57-67 Used 72-80	77-91 98-108
Exhaust Manifold Bolts	10-17	14-23
Exhaust Pipe to Exhaust Manifold	20-35	27-47
Flywheel Bolts	83-90	113-122
Front Panel Bolts	16-20	22-27
Fuel Injector Holddown Nut	23-32	31-43
Glow Plug	15-18	20-24
High Pressure Tubeline Fittings	14-29	19-39
Hydraulic Housing Mounting Bolts	25	34
Hydraulic Reservoir Strap Bolts	16-20	22-27
Hydrostatic Motor Mounting Bolts	65-70	88-95
Hydrostatic Pump Mounting Bolts	65-70	88-95
Hydrostatic Pump Pulley Bolt	175-200	237-271
Idler Gear Bolts	10-12	14-16
Injection Nozzles	36-51	46-69
Injector Nozzle Body	43-58	59-79
Injection Pump Gear Bolt	43-51	58-69
Injection Pump Idler Gear Bolt	72-87	98-118
Injection Pump Mounting Bolts	10-17	14-23
Intake Manifold Bolts	10-17	14-23
Main Bearing Cap Bolts	116-130	157-176
Main Relief Valve	35-40	47-54
Oil Filter Housing Bolts	10-17	157-176
Oil Pan Nuts & Bolts	14-19	19-26
Oil Pump Bolts (Hollow)	9-12	12-16
Oil Pump Mounting Bolts	10-17	14-23
Operator Cab Fastening Nuts	40-50	54-68
Operator Cab Pivot Bolts & Nuts	25-35	34-47
Pedal Lock Linkage to Main Frame Bolts	7-8	9,5-10,8
Pedal Lock Linkage Tab Bolt	25	34
Pivot Pins Lock Bolt & Nut	18-20	24-27
Rocker Arm Adjustment Nut	12-14	16-19
Rocker Arm Bracket Bolts	36-43	49-58
Seat Belt Fastening Bolts	40-45	54-61
Seat Mounting Bolts	9-11	12-15
Seat Bar Pivot Bolts	25-28	34-38

TORQUE SPECIFICATIONS FOR LOADER (Cont'd)**Specifications (Cont'd)**

Item (Cont'd)	Ft.-Lbs.	Nm
Thermostat Housing Bolts	10-17	14-23
Timing Case Bolts	11-17	15-23
Timing Case Cover Bolts	11-17	15-23
Valve Cover Nuts	6-13	8-18
Water Jacket Tube (Outside)	10-17	14-23
Water Pump Bolts	11-18	15-24
Wheel Nuts	105-115	142-156

Provided for Free by Trenchwell.com
Shop Aftermarket Parts

TORQUE SPECIFICATIONS FOR BOLTS**Torque For General SAE Bolts**

The following table shows standard torque specifications for bolts with zinc phosphate coating. Bolts purchased from Melroe that have zinc phosphate coating are specified by the letter "H" following the part number.

THREAD SIZE		SAE GRADE 5	SAE GRADE 8
INCH. LBS. (Nm)	.250	80-90 (9,0-10,2)	110-120 (12,4-13,6)
	.3125	180-200 (20,3-22,6)	215-240 (24,2-27,1)
FOOT LBS. (Nm)	.375	25-28 (34-38)	35-40 (47-54)
	.4375	40-45 (54-61)	60-65 (81-88)
	.500	65-70 (88-95)	90-100 (122-136)
	.5625	90-100 (122-136)	125-140 (170-190)
	.625	125-140 (170-190)	175-190 (240-260)
	.750	220-245 (300-330)	300-330 (410-450)
	.875	330-360 (450-490)	475-525 (645-710)
	1.000	475-525 (645-710)	725-800 (985-1085)
	1.125	650-720 (880-975)	1050-1175 (1425-1600)
	1.250	900-1000 (1200-1360)	1475-1625 (2000-2200)
	1.375	1200-1350 (1630-1830)	2000-2200 (2720-2980)
	1.500	1500-1650 (2040-2240)	2600-2850 (3530-3870)
	1.625	2000-2800 (2720-2980)	3450-3800 (4680-5150)
	1.750	2500-2750 (3390-3730)	4300-4800 (5830-6500)
	1.875	3150-3500 (4270-4750)	5500-6100 (7450-8300)
2.000	3800-4200 (5150-5700)	6500-7200 (8800-9800)	

TORQUE SPECIFICATIONS FOR BOLTS (Cont'd)**Torque For General Metric Bolts**

Thread Size (Dia. x Pitch)	Material		
	Head Mark 4	Head Mark 7	Head Mark 10
M 5 x 0.8		3–4 ft.-lbs. (4–5 Nm)	
M 6 x 1.0		6–7 ft.-lbs. (8–9 Nm)	6–9 ft.-lbs. (8–12 Nm)
M 8 x 1.25	6–9 ft.-lbs. (8–12 Nm)	11–16 ft.-lbs. (15–22 Nm)	18–25 ft.-lbs. (24–34 Nm)
M 10 x 1.25	13–18 ft.-lbs. (18–24 Nm)	22–30 ft.-lbs. (30–41 Nm)	36–50 ft.-lbs. (49–68 Nm)
M 12 x 1.25	22–30 ft.-lbs. (30–41 Nm)	40–54 ft.-lbs. (54–73 Nm)	69–87 ft.-lbs. (94–118 Nm)
M 14 x 1.25	36–50 ft.-lbs. (49–68 Nm)	58–80 ft.-lbs. (79–108 Nm)	116–137 ft.-lbs. (157–186 Nm)

HYDRAULIC CONNECTION SPECIFICATIONS

IMPORTANT

When repairing hydrostatic and hydraulic systems, clean the work area before disassembly and keep all parts clean. Always use caps and plugs on hoses, tubelines and ports to keep dirt out. Dirt can quickly damage the system.

I-2003-0888

O-ring Face Seal Connection

When the fitting is tightened, you can *feel* when the fitting is tight to eliminate leakage caused by under or over torqued fittings. Use vaseline petroleum jelly to hold the O-ring in position until the fittings are assembled [A].

Straight Thread O-ring Fitting

Lubricate the O-ring before installing the fitting. Loosen the jam nut and install the fitting. Tighten the jam nut until the washer is tight against the surface [B].

Tubelines And Hoses

Replace any tubelines that are bent or flattened. They will restrict flow, which will slow hydraulic action and cause heat.

Replace hoses which show signs of wear, damage or weather cracked rubber.

Always use two wrenches when loosening and tightening hose or tubeline fittings.

Flare Fitting

Use the following procedure to tighten the flare fitting:

Tighten the nut until it makes contact with the seat. Make a mark across the *flats* of both the male and female parts of the connection (Item 1) [C].

Use the chart below to find the correct tightness needed (Item 2) [C]. If the fitting leaks after tightening, disconnect it and inspect the seat area for damage.

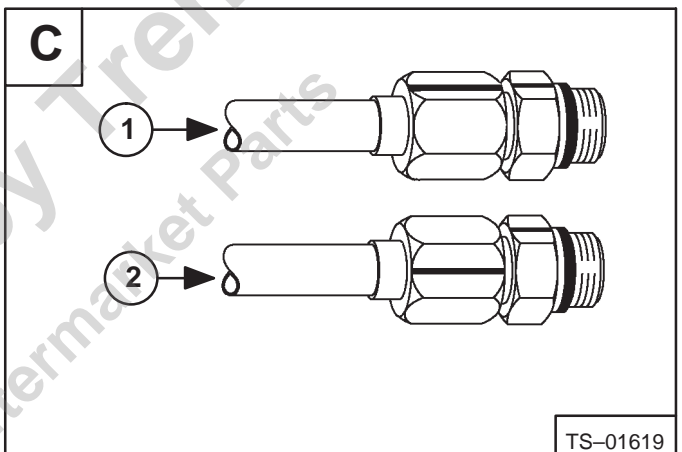
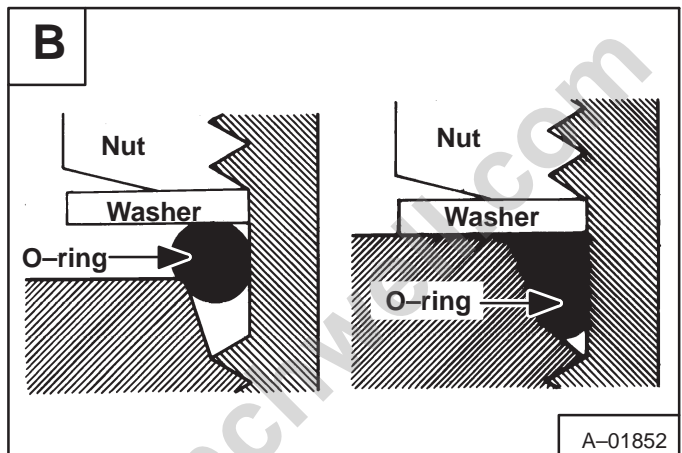
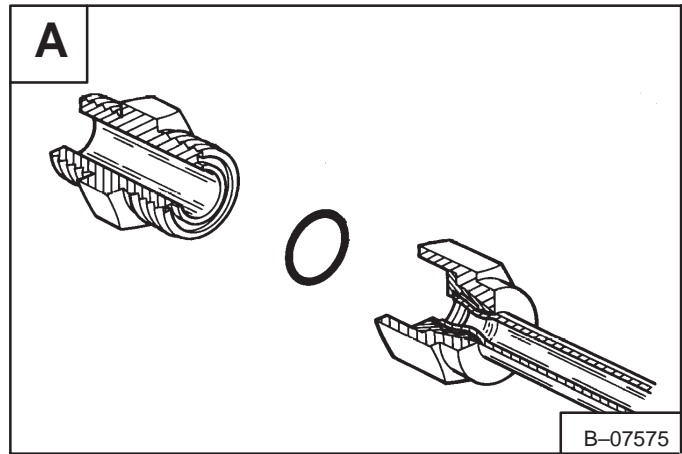

HYDRAULIC CONNECTION SPECIFICATIONS (CONT'D)

O-ring Flare Fitting

The flare is the primary seal, the O-ring is the secondary seal and helps absorb vibration and pressure pulses at the connection [A].

If necessary, the O-ring-flare fitting can be used without an O-ring.

Use the following procedure to tighten the O-ring flare fitting.

Tighten the nut until it contacts with the seat. Make a mark across the flats of both the male and female parts of the connection (Item 1) [B].

Use the chart below to find the correct tightness needed (Item 2) [B]. If the fitting leaks after tightening, disconnect it and inspect the seat area for damage.

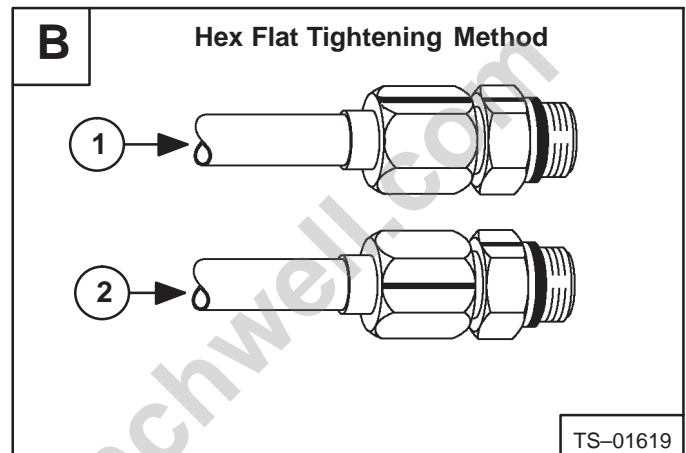
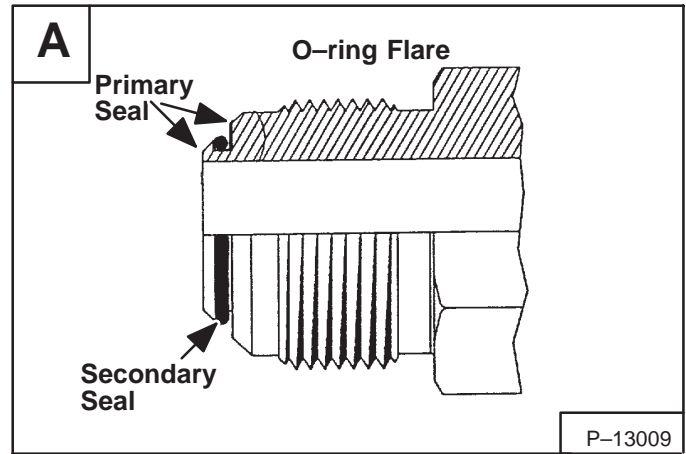

HYDRAULIC CONNECTION SPECIFICATIONS (CONT'D)
O-ring Flare Fitting (Cont'd)

NOTE: O-ring flare fittings are not recommended in all applications. Use the standard flare fittings in these applications.

Do not use a O-ring flare fitting when a copper bonnet orifice is used. When tightened the connection at the bonnet may distort the flare face and prevent it from sealing.

Use a standard flare fitting (Item 1) [A] as shown.

When a O-ring flare fitting is used as a straight thread port adapter the O-ring flare face is not used to seal. The O-ring may come off the fitting and enter the system.

Always remove the O-ring (Item 1) [B] from the flare face as shown.

An O-ring (Item 2) [B] is added to the flat boss of the fitting to seal the connection in this application.

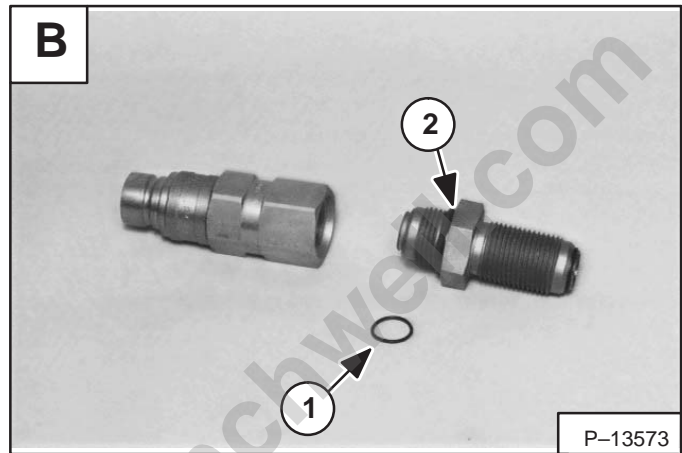
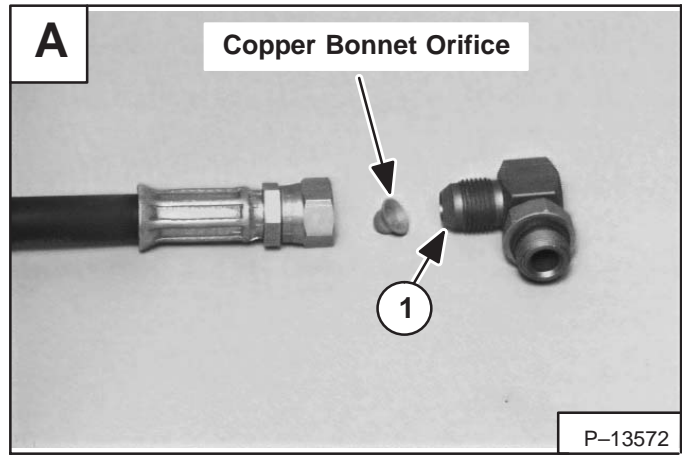

Provided for Free by Trencher.com
Shop Aftermarket Parts

HYDRAULIC CONNECTION SPECIFICATIONS (CONT'D)
Port Seal Fitting

The nut is the primary seal, the O-ring is the secondary seal and helps absorb vibration and pressure pulses at the connection [A].

The hex portion of the nut does not contact the surface of the component when the nut is tight.

Use the following procedure to tighten the port seal fitting:

Port seal and nut, washer and O-ring (O-ring Boss) fittings use the same tightening torque valve chart.

If a torque wrench cannot be used, use the following method.

Tighten the nut until it just makes metal to metal contact, you can feel the resistance.

Tighten the nut with a wrench no more than one hex flat maximum.

Do not over tighten the port seal fitting.

NOTE: If a torque wrench cannot be used, use the hex flat tightening method as an approximate guideline.

NOTE: Port seal fittings are not recommended in all applications. Use O-ring boss fittings in these applications.

Do not use port seal fittings when a thread in orifice (Item 1) [B] is used in the port. The orifice may interfere with the fitting and prevent it from sealing.

Use an O-ring boss fitting (Item 2) [B] as shown.

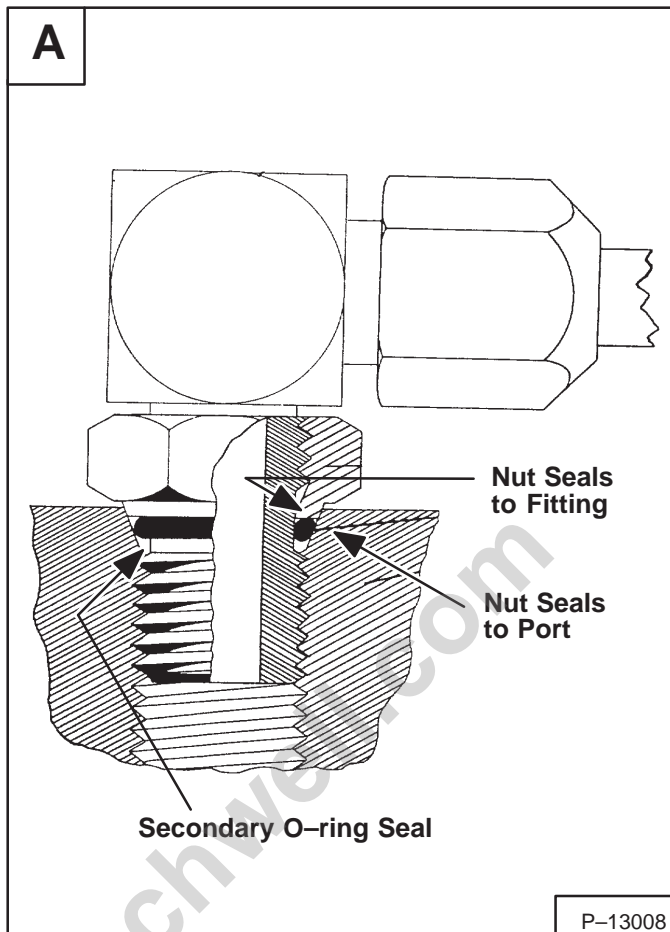

Port Seal and O-ring Boss Tightening Torque

Fitting Nut Wrench Size	Thread Size	TORQUE Ft.-lbs. (Nm)
11/16"	9/16" – 18	22 (30)
15/16"	3/4" – 16	40 (54)
1-1/8"	7/8" – 14	60 (81)
1-1/4"	1-1/16" – 12	84 (114)
1-1/2"	1-5/16" – 12	118 (160)

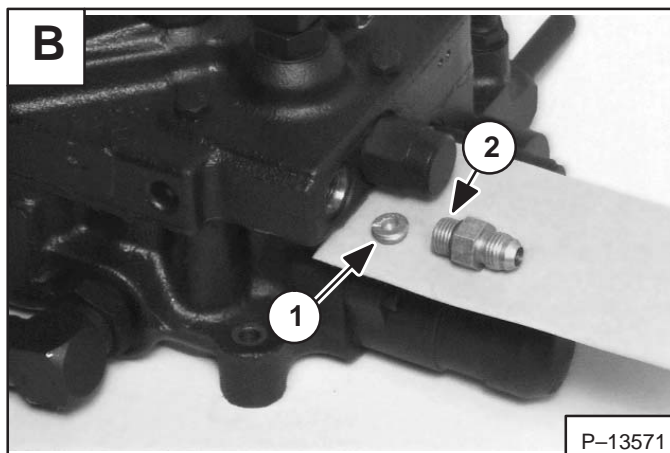

HYDRAULIC/HYDROSTATIC FLUID SPECIFICATIONS**Specifications**

Use Melroe hydraulic/hydrostatic transmission fluid (P/N 6563328). If this fluid is not available, use 10W-30 or 10W-40 SAE Motor Oil (5W-30 for 0°F [-18°C] and Below).

DO NOT use automatic transmission fluids in the loader or permanent damage to the transmission will result.

WARNING

Diesel fuel or hydraulic fluid under pressure can penetrate skin or eyes causing serious injury. Fluid leaks under pressure may not be visible. Use a piece of cardboard or wood to find leaks. Do not use your bare hand. Wear safety goggles. If fluid enters skin or eyes, get immediate medical attention.

W-2074-1285

When temperatures below zero degree F (-18°C) are common, the loader must be kept in a warm building. Extra warm-up time must be used each time the loader is started during cold temperature conditions. Cold fluid will not flow easily and it makes action of the hydraulic function slower. Loss of fluid flow to the hydrostatic transmission pump (indicated by "TRANS" light "ON") can cause transmission damage in less than 60 seconds.

WARNING

During cold weather 32°F (0°C) and below, do not operate machine until the engine has run for at least five (5) minutes at less than half throttle. This warm-up period is necessary for foot pedal operation and safe stopping. Do not operate controls during warm-up period. When temperatures are below -20°F (30°C), the hydrostatic oil must be heated or kept warm. The hydrostatic system will not get enough oil at low temperatures. Park the machine in an area where the temperature will be above 0°F (-18°C), if possible.

W-2027-1285

DECIMAL AND MILLIMETER EQUIVALENTS

FRACTIONS	DECIMALS	MM	FRACTIONS	DECIMALS	MM
	1/64	0.015625		33/64	0.515625
1/32		0.03125	17/32		0.53125
	3/64	0.046875		35/64	0.546875
1/16		0.0625	9/16		0.5625
	5/64	0.078125		37/64	0.578125
3/32		0.09375	19/32		0.59375
	7/64	0.109375		39/64	0.609375
1/8		0.1250	5/8		0.6250
	9/64	0.140625		41/64	0.640625
5/32		0.15625	21/32		0.65625
	11/64	0.171875		43/64	0.671875
3/16		0.1875	11/16		0.6875
	13/64	0.203125		45/64	0.703125
7/32		0.21875	23/32		0.71875
	15/64	0.234375		47/64	0.734375
1/4		0.2500	3/4		0.7500
	17/64	0.265625		49/64	0.765625
9/32		0.28125	25/32		0.78125
	19/64	0.296875		51/64	0.796875
5/16		0.3125	13/16		0.8125
	21/64	0.328125		53/64	0.828125
11/32		0.34375	27/32		0.84375
	23/64	0.359375		55/64	0.859375
3/8		0.3750	7/8		0.8750
	25/64	0.390625		57/64	0.890625
13/32		0.40625	29/32		0.90625
	27/64	0.421875		59/64	0.921875
7/16		0.4375	15/16		0.9375
	29/64	0.453125		61/64	0.953125
15/32		0.46875	31/32		0.96875
	31/64	0.484375		63/64	0.984375
1/2		0.5000	1		1.000

1 mm = 0.03937"

0.001" = 0.0254 mm

U.S. TO METRIC CONVERSION

	TO CONVERT	INTO	MULTIPLY BY
LINEAR MEASUREMENT	Miles	Kilometers	1.609
	Yards	Meters	0.9144
	Feet	Meters	0.3048
	Feet	Centimeters	30.48
	Inches	Meters	0.0254
	Inches	Centimeters	2.54
	Inches	Millimeters	25.4
AREA	Square Miles	Square Kilometers	2.59
	Square Feet	Square Meters	0.0929
	Square Inches	Square Centimeters	6.452
	Acre	Hectare	0.4047
VOLUME	Cubic Yards	Cubic Meters	0.7646
	Cubic Feet	Cubic Meters	0.02832
	Cubic Inches	Cubic Centimeters	16.39
WEIGHT	Tons (Short)	Metric Tons	0.9078
	Pounds	Kilograms	0.4536
	Ounces (Avdp.)	Grams	28.3495
PRESSURE	Pounds/Sq. In.	Kilopascal	6.895
WORK	Foot-Pounds	Newton-Metre	1.356
LIQUID VOLUME	Quarts	Liters	0.9463
	Gallons	Liters	3.785
LIQUID FLOW	Gallons/Minute	Liters/Minute	3.785
TEMPERATURE	Fahrenheit	Celsius	1. Subtract 32°
			2. Multiply by 5/9



Provided for Free by www.menckwell.com
Shop Aftermarket Parts

MELROE
INGERSOLL-RAND



SERVICE MANUAL REVISION

850-001
Revision Number
29 April 1991
Date

ROUTE TO ATTENTION	
PARTS MANAGER	<input type="checkbox"/>
SERVICE MANAGER	<input checked="" type="checkbox"/>
SALES MANAGER	<input type="checkbox"/>

AFFECTING:

Product BOBCAT LOADER

Model 853

Manual No. 6720755 (2-91)

Revise your Service Manual with the enclosed page(s) as shown below.

TAKE OUT

1-21, 1-22

PUT IN

1-21, 1-22 (Revised Apr. 91)

Provided for Free by Trenchwell.com
Shop Aftermarket Parts

Provided for Free by Trenchwell.com
Shop Aftermarket Parts

MELROE
INGERSOLL-RAND



SERVICE MANUAL REVISION

850-002
Revision Number
10 July 1991
Date

ROUTE TO ATTENTION	
PARTS MANAGER	<input type="checkbox"/>
SERVICE MANAGER	<input checked="" type="checkbox"/>
SALES MANAGER	<input type="checkbox"/>

AFFECTING:

Product BOBCAT LOADER

Model 853

Manual No. 6720755 (2-91)

Revise your Service Manual with the enclosed page(s) as shown below.

TAKE OUT

1-25, 1-26
1-29

HYDRAULIC/HYDROSTATIC FLOW CHART
For Model
853
Chart #6720800 (Printed February 1991)
CHART LEGEND

3-7, 3-8
3-9, 3-10

4-9, 4-10

5-7, 5-8

8-7, 8-8

PUT IN

1-25 (Revised July 91), 1-26 (Revised July 91)
1-29 (Revised July 91)

HYDRAULIC/HYDROSTATIC FLOW CHART
For Model
853
Chart #6720800 (Printed July 1991)
CHART LEGEND & FLUID FLOW EXPLANATION

3-7, 3-8 (Revised July 91)
3-9 (Revised July 91), 3-10

4-9 (Revised July 91), 4-10 (Revised July 91)

5-7 (Revised July 91), 5-8

8-7 (Revised July 91), 8-8

Provided for Free by Trenchwell.com
Shop AftermarketParts

Provided for Free by Trenchwell.com
Shop Aftermarket Parts

MELROE
INGERSOLL-RAND



SERVICE MANUAL REVISION

850-003
Revision Number
20 September 1991
Date

ROUTE TO ATTENTION	
PARTS MANAGER	<input type="checkbox"/>
SERVICE MANAGER	<input checked="" type="checkbox"/>
SALES MANAGER	<input type="checkbox"/>

AFFECTING:

Product BOBCAT LOADER

Model 853

Manual No. 6720755 (2-91)

Revise your Service Manual with the enclosed page(s) as shown below.

TAKE OUT

WIRING DIAGRAM (P/N 6720801)
Model 853 (S/N 11001 & Above)
(Printed February 1991) 3 Of 3 Pages

ENGINE SERVICE – TAB PAGE

7-23, 7-24

PUT IN

HYDRAULIC/HYDROSTATIC FLOW CHART
For Model
853H
Chart #6720956 (Printed September 1991)

HYDRAULIC/HYDROSTATIC SYSTEM OPERATION
To Be Used With
HYDRAULIC/HYDROSTATIC FLOW CHART
For Model
853H
Chart #6720956 (Printed September 1991)

WIRING DIAGRAM (P/N 6720801)
Model 853 (S/N 11011 Thru 11353)
(Printed September 1991) 3 Of 3 Pages

WIRING DIAGRAM (P/N 6720958)
Model 853 (S/N 11354 & Above) & 853H
(Printed September 1991) 4 Of 4 Pages

ENGINE SERVICE – TAB PAGE
(Revised September 1991)

7-23 (Revised Sept. 1991), 7-24 (Revised Sept. 1991)

Provided for Free by Trenchwell.com
Shop Aftermarket Parts

Provided for Free by Trenchwell.com
Shop Aftermarket Parts

MELROE
INGERSOLL-RAND



SERVICE MANUAL REVISION

850-004

Revision Number

6 January 1992

Date

ROUTE TO ATTENTION

PARTS MANAGER SERVICE MANAGER SALES MANAGER

AFFECTING:

Product BOBCAT LOADERModel 853Manual No. 6720755 (2-91)

Revise your Service Manual with the enclosed pages as shown below.

TAKE OUT

MAINTENANCE SAFETY
MAINTENANCE SAFETY (Cont'd)

PREVENTIVE MAINTENANCE-TAB PAGE

1-1, 1-2
1-3, 1-4
1-5, 1-6
1-9, 1-10
1-11, 1-12
1-21, 1-22

HYDRAULIC SYSTEM - TAB PAGE
2-19

WIRING DIAGRAM (P/N 6720958)
Model 853 (S/N 11354 & Above) & 853H
(Printed September 1991) 1 Of 4 Pages

WIRING DIAGRAM (P/N 6720958)
Model 853 (S/N 11354 & Above) & 853H
(Printed September 1991) 2 Of 4 Pages

WIRING DIAGRAM (P/N 6720958)
Model 853 (S/N 11354 & Above) & 853H
(Printed September 1991) 3 Of 4 Pages

WIRING DIAGRAM (P/N 6720958)
Model 853 (S/N 11354 & Above) & 853H
(Printed September 1991) 4 Of 4 Pages

8-1, 8-2

PUT IN

MAINTENANCE SAFETY (Revised Jan. 92)
MAINTENANCE SAFETY (Cont'd)

PREVENTIVE MAINTENANCE-TAB PAGE
(Revised Jan. 92)

1-1 (Revised Jan. 92), 1-2
1-3 (Revised Jan. 92), 1-4 (Revised Jan. 92)
1-5 (Revised Jan. 92), 1-6 (Revised Jan. 92)
1-9, 1-10 (Revised Jan. 92)
1-11 (Revised Jan. 92), 1-12
1-21, 1-22 (Revised Jan. 92)

HYDRAULIC SYSTEM - TAB PAGE (Revised Jan. 92)
2-19 (Revised Jan. 92)

WIRING DIAGRAM (P/N 6720958)
Model 853 (S/N 11354 & Above) & 853H
(Printed January 1992) 1 Of 4 Pages

WIRING DIAGRAM (P/N 6720958)
Model 853 (S/N 11354 & Above) & 853H
(Printed January 1992) 2 Of 4 Pages

WIRING DIAGRAM (P/N 6720958)
Model 853 (S/N 11354 & Above) & 853H
(Printed January 1992) 3 Of 4 Pages

WIRING DIAGRAM (P/N 6720958)
Model 853 (S/N 11354 & Above) & 853H
(Printed January 1992) 4 Of 4 Pages

8-1 (Revised Jan. 92), 8-2

Provided for Free by Trenchwell.com
Shop Aftermarket Parts

MELROE
INGERSOLL-RAND



SERVICE MANUAL REVISION

850-005
Revision Number
10 April 1992
Date

ROUTE TO ATTENTION	
PARTS MANAGER	<input type="checkbox"/>
SERVICE MANAGER	<input checked="" type="checkbox"/>
SALES MANAGER	<input type="checkbox"/>

AFFECTING:

Product BOBCAT LOADER

Model 853

Manual No. 6720755 (2-91)

Revise your Service Manual with the enclosed pages as shown below.

TAKE OUT

PREVENTIVE MAINTENANCE – TAB PAGE
(Revised Jan. 92)

1-29 (Revised July 91)

HYDROSTATIC SYSTEM – TAB PAGE

3-17, 3-18
3-19

PUT IN

PREVENTIVE MAINTENANCE – TAB PAGE
(Revised April 92)

1-29 (Revised July 91), 1-30 (Added April 92)

HYDROSTATIC SYSTEM – TAB PAGE
(Revised April 92)

3-17, 3-18 (Revised April 92)
3-19 thru 3-26 (Added April 92)

*WIRING DIAGRAM (P/N 6722195)
BUCKET POSITION VALVE LOCKOUT (Optional)
Model 753, 7753, 843, 843B & 853
(Printed April 1992)

* NOTE: Put the WIRING DIAGRAM (P/N 6722195) at the beginning of Section 6.

Provided for Free by Trenchwell.com
Shop AftermarketParts.com

Provided for Free by Trenchwell.com
Shop Aftermarket Parts

MELROE
INGERSOLL-RAND



SERVICE MANUAL REVISION

850-006
Revision Number
29 June 1992
Date

ROUTE TO ATTENTION	
PARTS MANAGER	<input type="checkbox"/>
SERVICE MANAGER	<input checked="" type="checkbox"/>
SALES MANAGER	<input type="checkbox"/>

AFFECTING:

Product BOBCAT LOADER

Model 853

Manual No. 6720755 (2-91)

Revise your Service Manual with the enclosed pages as shown below.

TAKE OUT

6-11, 6-12

7-23 (Revised Sept. 92), 7-24 (Revised Sept. 91)
7-27, 7-28

PUT IN

6-11 (Revised June 92), 6-12

7-23 (Revised Sept. 91), 7-24 (Revised June 92)
7-27 (Revised June 92), 7-28 (Revised June 92)

Provided for Free by Trenchwell.com
Shop Aftermarket Parts

Provided for Free by Trenchwell.com
Shop Aftermarket Parts

MELROE
INGERSOLL-RAND



SERVICE MANUAL REVISION

850-007

Revision Number

30 December 1992

Date

ROUTE TO ATTENTION

PARTS MANAGER SERVICE MANAGER SALES MANAGER

AFFECTING:

Product BOBCAT LOADERModel 853Manual No. 6720755 (2-91)

Revise your Service Manual with the enclosed pages as shown below.

TAKE OUT

WIRING DIAGRAM (P/N 6720958)
Model 853 (S/N 11354 & Above) & 853H
(Printed January 1992) 1 Of 4 Pages

WIRING DIAGRAM (P/N 6720958)
Model 853 (S/N 11354 & Above) & 853H
(Printed January 1992) 2 Of 4 Pages

WIRING DIAGRAM (P/N 6720958)
Model 853 (S/N 11354 & Above) & 853H
(Printed January 1992) 3 Of 4 Pages

WIRING DIAGRAM (P/N 6720958)
Model 853 (S/N 11354 & Above) & 853H
(Printed January 1992) 4 Of 4 Pages

PUT IN

WIRING DIAGRAM (P/N 6720958)
Model 853 (S/N 11354 Thru 12360) & 853H (S/N 11308 & Below)
(Printed December 1992) 1 Of 4 Pages

WIRING DIAGRAM (P/N 6720958)
Model 853 (S/N 11354 Thru 12360) & 853H (S/N 11308 & Below)
(Printed December 1992) 2 Of 4 Pages

WIRING DIAGRAM (P/N 6720958)
Model 853 (S/N 11354 Thru 12360) & 853H (S/N 11308 & Below)
(Printed December 1992) 3 Of 4 Pages

WIRING DIAGRAM (P/N 6720958)
Model 853H (S/N 11308 & Below)
(Printed December 1992) 4 Of 4 Pages

WIRING DIAGRAM (P/N 6722313)
Model 853 Base (S/N 25001 & Above)
(Printed December 1992) 1 Of 3 Pages

WIRING DIAGRAM (P/N 6722313)
Model 853 Base (S/N 25001 & Above)
(Printed December 1992) 2 Of 3 Pages

WIRING DIAGRAM (P/N 6722313)
Model 853 Base (S/N 25001 & Above)
(Printed December 1992) 3 Of 3 Pages

WIRING DIAGRAM (P/N 6722312)
Model 853 (S/N 12361 & Above) & 853H (S/N 11309 & Above)
Model 853 Plus (S/N 50001 & Above) & 853H Plus (S/N 75001 & Above)
(Printed December 1992) 1 Of 4 Pages

WIRING DIAGRAM (P/N 6722312)
Model 853 (S/N 12461 & Above) & 853H (S/N 11335 & Above)
Model 853 Plus (S/N 50001 & Above) & 853H Plus (S/N 75001 & Above)
(Printed December 1992) 2 Of 4 Pages

WIRING DIAGRAM (P/N 6722312)
Model 853 (S/N 12361 & Above) & 853H (S/N 11309 & Above)
Model 853 Plus (S/N 50001 & Above) & 853H Plus (S/N 75001 & Above)
(Printed December 1992) 3 Of 4 Pages

WIRING DIAGRAM (P/N 6722312)
Model 853H (S/N 11309 & Above) & 853H Plus (S/N 75001 & Above)
(Printed December 1992) 4 Of 4 Pages

TAKE OUT

PUT IN

HYDRAULIC/HYDROSTATIC FLOW CHART

For Model

853H Plus (S/N 75001 & Above)

Chart #6722311 (Printed December 1992)

HYDRAULIC/HYDROSTATIC SYSTEM OPERATION

To Be Used With

HYDRAULIC/HYDROSTATIC FLOW CHART

For Model

853 Plus (S/N 50001 & Above) & 853 Base (S/N 25001 & Above)

Chart #6722310 (Printed December 1992)

Provided for Free by Trenchwell.com
Shop Aftermarket Parts

MELROE
INGERSOLL-RAND



SERVICE MANUAL REVISION

850-008

Revision Number

5 March 1993

Date

ROUTE TO ATTENTION

PARTS MANAGER SERVICE MANAGER SALES MANAGER

AFFECTING:

Product BOBCAT LOADERModel 853Manual No. 6720755 (2-91)

Revise your Service Manual with the enclosed pages as shown below.

TAKE OUT

Foreword Page

Contents Page

Page i, Page ii
Page iii

Preventive Maintenance Contents (Revised Apr. 92)

1-1 (Revised Jan. 92), 1-2
1-5 (Revised Jan. 92), 1-6 (Revised Jan. 92)
1-7, 1-8
1-17, 1-18
1-25 (Revised July 91), 1-26 (Revised July 91)

Hydraulic System Contents (Revised Jan. 92)

2-1, 2-2
2-7, 2-8
2-9, 2-10
2-11, 2-12
2-13, 2-14
2-15, 2-16
2-17, 2-18
2-19 (Revised Jan. 92)

Hydrostatic System Contents (Revised Apr. 92)

3-1, 3-2
3-3, 3-4
3-7, 3-8 (Revised July 91)
3-9 (Revised July 91), 3-10
3-11, 3-12
3-13, 3-14
3-15, 3-16

Drive System Contents

4-1, 4-2

Main Frame Contents

5-1, 5-2
5-3, 5-4
5-5, 5-6

Electrical System Contents

6-1, 6-2
6-11 (Revised June 92), 6-12
6-13, 6-14

PUT IN

Foreword Page

Contents Page (Revised Mar. 93)

Page i, Page ii (Revised Mar. 93)
Page iii (Revised Mar. 93), Page iv (Added Mar. 93)
Page v (Added Mar. 93), Page vi (Added Mar. 93)

Preventive Maintenance Contents (Revised Mar. 93)

1-1 (Revised Mar. 93), 1-2
1-5 (Revised Mar. 93), 1-6 (Revised Mar. 93)
1-7 (Revised Mar. 93), 1-8 (Revised Mar. 93)
1-17, 1-18 (Revised Mar. 93)
1-25 (Revised Mar. 93), 1-26 (Revised Mar. 93)

Hydraulic System Contents (Revised Mar. 93)

2-1 (Revised Mar. 93), 2-2
2-7 (Revised Mar. 93), 2-8 (Revised Mar. 93)
2-9 (Revised Mar. 93), 2-10 (Revised Mar. 93)
2-11 (Revised Mar. 93), 2-12 (Revised Mar. 93)
2-13 (Revised Mar. 93), 2-14 (Revised Mar. 93)
2-15 (Revised Mar. 93), 2-16 (Revised Mar. 93)
2-17 (Revised Mar. 93), 2-18 (Revised Mar. 93)
2-19 (Revised Mar. 93), 2-20 (Added Mar. 93)
2-21 (Added Mar. 93)

Hydrostatic System Contents (Revised Mar. 93)

3-1 (Revised Mar. 93), 3-2
3-3 (Revised Mar. 93), 3-4
3-7, 3-8 (Revised Mar. 93)
3-9 (Revised Mar. 93), 3-10 (Revised Mar. 93)
3-11 (Revised Mar. 93), 3-12
3-13 (Revised Mar. 93), 3-14
3-15 (Revised Mar. 93), 3-16

Drive System Contents (Revised Mar. 93)

4-1 (Revised Mar. 93), 4-2

Main Frame Contents (Revised Mar. 93)

5-1, 5-2 (Revised Mar. 93)
5-3 (Revised Mar. 93), 5-4 (Revised Mar. 93)
5-5 (Revised Mar. 93), 5-6

Electrical System Contents (Revised Mar. 93)

6-1 (Revised Mar. 93), 6-2 (Revised Mar. 93)
6-11 (Revised Mar. 93), 6-12 (Revised Mar. 93)
6-13 (Revised Mar. 93), 6-14 (Revised Mar. 93)
6-15 (Added Mar. 93)

TAKE OUT

Engine Service Contents (Revised Sept. 91)

- 7-1, 7-2
- 7-3, 7-4
- 7-5, 7-6
- 7-7, 7-8
- 7-9, 7-10
- 7-11, 7-12
- 7-13, 7-14
- 7-15, 7-16
- 7-17, 7-18
- 7-19, 7-20
- 7-21, 7-22

Specifications Contents

PUT IN

Engine Service Contents (Revised Mar. 93)

- 7-1, 7-2 (Revised Mar. 93)
- 7-3, 7-4 (Revised Mar. 93)
- 7-5 (Revised Mar. 93), 7-6
- 7-7, 7-8 (Revised Mar. 93)
- 7-9 (Revised Mar. 93), 7-10 (Revised Mar. 93)
- 7-11 (Revised Mar. 93), 7-12 (Revised Mar. 93)
- 7-13 (Revised Mar. 93), 7-14 (Revised Mar. 93)
- 7-15 (Revised Mar. 93), 7-16 (Revised Mar. 93)
- 7-17 (Revised Mar. 93), 7-18 (Revised Mar. 93)
- 7-19 (Revised Mar. 93), 7-20 (Revised Mar. 93)
- 7-21 (Revised Mar. 93), 7-22

Specifications Contents (Revised Mar. 93)

Provided for Free by Trenchwell.com
Shop Aftermarket Parts

MELROE
INGERSOLL-RAND



SERVICE MANUAL REVISION

850-009
Revision Number
5 January 1994
Date

ROUTE TO ATTENTION	
PARTS MANAGER	<input type="checkbox"/>
SERVICE MANAGER	<input checked="" type="checkbox"/>
SALES MANAGER	<input type="checkbox"/>

AFFECTING:

Product BOBCAT LOADER

Model 853

Manual No. 6720755 (2-91)

NOTICE Insert This Sheet With The Above Listed Manual For Future Reference.

The following pages are a revision to the 853 Service Manual P/N 6720755 (2-91).

Take out the pages shown and put in the revised pages as follows:

TAKE OUT

PUT IN

HYDRAULIC/HYDROSTATIC FLOW CHART
Chart #6722825 (Printed November 1993)

Provided for Free by Trenchwell.com
Shop Aftermarket Parts

Provided for Free by Trenchwell.com
Shop Aftermarket Parts

MELROE
INGERSOLL-RAND



SERVICE MANUAL REVISION

850-010
Revision Number
17 February 1994
Date

ROUTE TO ATTENTION	
PARTS MANAGER	<input type="checkbox"/>
SERVICE MANAGER	<input checked="" type="checkbox"/>
SALES MANAGER	<input type="checkbox"/>

AFFECTING:

Product BOBCAT LOADER

Model 853

Manual No. 6720755 (2-91)

NOTICE Insert This Sheet With The Above Listed Manual For Future Reference.

The following pages are a revision to the 853 Service Manual P/N 6720755 (2-91).

Take out the pages shown and put in the revised pages as follows:

TAKE OUT

HYDRAULIC/HYDROSTATIC SYSTEM OPERATION
CHART LEGEND and FLUID FLOW EXPLANATION

PUT IN

HYDRAULIC/HYDROSTATIC SYSTEM OPERATION
CHART LEGEND and
FLUID FLOW EXPLANATION (Revised Feb. 94)

Provided for Free by Trenchwell.com
Shop Aftermarket Parts

Provided for Free by Trenchwell.com
Shop Aftermarket Parts

MELROE
INGERSOLL-RAND



SERVICE MANUAL REVISION

850-011

Revision Number

25 May 1994

Date

ROUTE TO ATTENTION

PARTS MANAGER SERVICE MANAGER SALES MANAGER

AFFECTING:

Product BOBCAT LOADERModel 853Manual No. 6720755 (2-91)

NOTICE

Insert This Sheet With The Above Listed Manual For Future Reference.

The following pages are a revision to the 853 Service Manual P/N 6720755 (2-91).

Take out the pages shown and put in the revised pages as follows:

TAKE OUT

3-7, 3-8 (Revised Mar. 93)
3-9 (Revised Mar. 93), 3-10 (Revised Mar. 93)

4-15, 4-16

ENGINE SERVICE – TAB PAGES
7-5 (Revised Mar. 93), 7-6

7-39, 7-40

8-3, 8-4

PUT IN

3-7, 3-8 (Revised May 94)
3-9 (Revised Mar. 93), 3-9a (Added May 94)
3-9b (Added May 94), 3-9C (Added May 94)
3-10 (Revised Mar. 93)

4-15 (Revised May 94), 4-16

ENGINE SERVICE – TAB PAGES (Revised May 94)
7-5 (Revised Mar. 93), 7-6 (Revised May 94)
7-6a thru 7-6m (Added May 94)
7-39, 7-40 (Revised May 94)

8-3, 8-4 (Revised May 94)

Provided for Free by Trenchwell.com
Shop Aftermarket Parts

Provided for Free by Trenchwell.com
Shop Aftermarket Parts

MELROE
INGERSOLL-RAND



SERVICE MANUAL REVISION

850-012
Revision Number
2 November 1998
Date

ROUTE TO ATTENTION	
PARTS MANAGER	<input type="checkbox"/>
SERVICE MANAGER	<input checked="" type="checkbox"/>
SALES MANAGER	<input type="checkbox"/>

AFFECTING:

Product BOBCAT LOADER

Model 853

Manual No. 6720755 (2-91)

NOTICE Insert This Sheet With The Above Listed Manual For Future Reference.

The following pages are a revision to the above Service Manual.

Take out existing pages and put in the new pages as listed below:

TAKE OUT

All of Hydraulic/Hydrostatic
Flow Charts, System Operations
and Fluid Flow Explanations

PUT IN

Glossary Of Hydraulic/Hydrostatic
Symbols For Loaders
(Place immediately after
HYDRAULIC SYSTEM – TAB PAGE

All of the enclosed
Hydraulic/Hydrostatic Schematics
(Printed November 1998)

Provided for Free by Trenchwell.com
Shop Aftermarket Parts

Provided for Free by Trenchwell.com
Shop Aftermarket Parts

MELROE
INGERSOLL-RAND



SERVICE MANUAL REVISION

850-13
Revision Number
1 June 1999
Date

ROUTE TO ATTENTION	
PARTS MANAGER	<input type="checkbox"/>
SERVICE MANAGER	<input checked="" type="checkbox"/>
SALES MANAGER	<input type="checkbox"/>

AFFECTING:

Product BOBCAT LOADER

Model 853

Manual No. 6720755 (6-99)

NOTICE Insert This Sheet With The Above Listed Manual For Future Reference.

TAKE OUT

853 Service Manual 6720755 (2-91)
Includes revisions 850-1 through 850-12

PUT IN

853 Service Manual 6720755 (6-99)
Includes revision 850-13

Replace your existing 853 Service Manual 6720755 (2-91) including revisions 850-1 through 850-12 with 853 Service Manual 6720755 (6-99) includes revision 850-13.

Provided for Free by www.youfixthis.com
Shop Aftermarket Parts at www.youfixthis.com

Provided for Free by Trenchwell.com
Shop Aftermarket Parts



SERVICE MANUAL REVISION

850-14
Revision Number
28 March 2003
Date

ROUTE TO ATTENTION	
PARTS MANAGER	<input type="checkbox"/>
SERVICE MANAGER	<input checked="" type="checkbox"/>
SALES MANAGER	<input type="checkbox"/>

AFFECTING:

 Product BOBCAT LOADER

 Model 853

 Manual No. 6720755 (6-99)
NOTICE

Insert This Sheet With The Appropriate Manual For Future Reference.

The following pages are a revision to the 853 Service Manual P/N 6720755 (6-99).

Take out the pages shown and put in the revised pages as follows:

TAKE OUT
PUT IN
REVISION DESCRIPTION

 HYDRAULIC/HYDROSTATIC
FLOW CHART
For Model
853H
Chart #6720956
(Printed March 2003)

Text Change



Bobcat®

Provided for Free by Trenchwell.com
Shop Aftermarket Parts